

1. RECEPTACLE ACCEPTS A .008-.014 THICK I.C. LEAD.
  2. TUBE LOADED.
- △ TWO .000030 MIN THK. GOLD STRIPES IN CONTACT AREA WITH TIN-LEAD (93/7) ON CONTACT LEGS, BALANCE OF CONTACT NICKEL PLATED.
  - △ TWO .000015 MIN THK. GOLD STRIPES IN CONTACT AREA WITH TIN-LEAD (93/7) ON CONTACT LEGS, BALANCE OF CONTACT NICKEL PLATED.

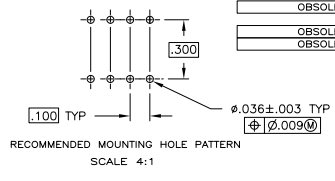
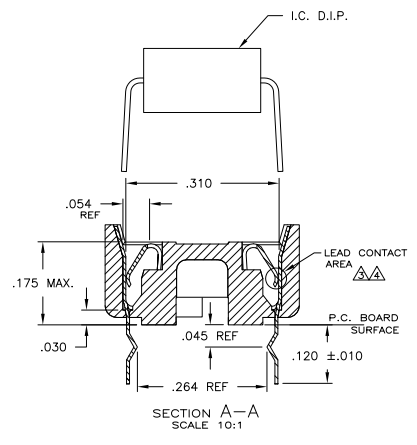
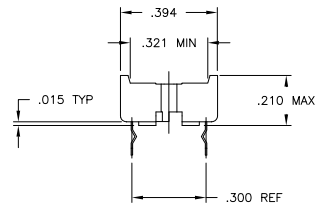
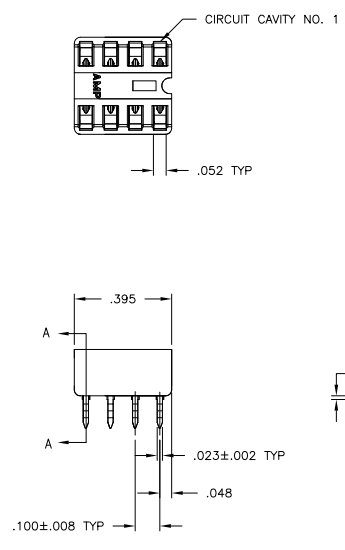

OBSOLETE	TINNED	PHOS.BRZ .008 THK	GLASS-FILLED THERMOPLASTIC, 94V-O, BLACK	2-641260-5
OBSOLETE	TINNED	PHOS.BRZ .008 THK	GLASS-FILLED THERMOPLASTIC, 94V-O, BLACK	2-641260-4
OBSOLETE	TINNED	PHOS.BRZ .008 THK	GLASS-FILLED THERMOPLASTIC, 94V-O, BLACK	2-641260-3
OBSOLETE	TINNED	BE.CU .006 THK	GLASS-FILLED THERMOPLASTIC, 94V-O, BLACK	2-641260-2
	TINNED	BE.CU .006 THK	GLASS-FILLED THERMOPLASTIC, 94V-O, BLACK	2-641260-1

CONTACT FINISH	CONTACT MAT'L	HOUSING MATERIAL	PART NO.

THIS DRAWING IS A CONTROLLED DOCUMENT.		REV	DATE	BY	CHK
DESIGNED	ENGINEER	108-1066	114-1049	A1	00779
DRAWN	DATE	108-1066	114-1049	A1	00779
CHECKED	DATE				
APPROVED	DATE				

TE Connectivity  
 SOCKET ASSY, DIP, 8  
 RET LEG, 8 POS, DIPLOMATE DL

CUSTOMER DRAWING