

12 DRAWING MADE IN THIRD ANGLE PROJECTION

3

2

LOG CM DIST 53

THIS DRAWING IS UNPUBLISHED. RELEASED FOR PUBLICATION
 © COPYRIGHT 19 BY AMP INCORPORATED, HARRISBURG, PA. ALL INTERNATIONAL RIGHTS RESERVED. AMP PRODUCTS MAY BE COVERED BY U.S. AND FOREIGN PATENTS AND/OR PATENTS PENDING.

REVOLUTIONS		DATE	APPROVED
✓	O	22/83	M/S/H
✓	A	9-9-82	EDW
✓	B	1-27-84	MC
✓	B1	6-29-85	NJ
✓	C	2-10-85	RS
✓	D	1-7-93	RS
✓	E	8-29-95	JH

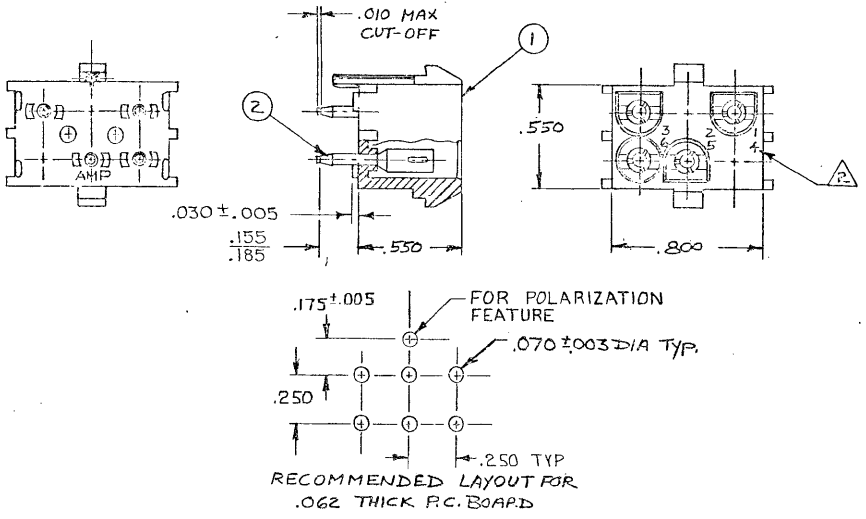

- 1. PARTS COMPLY WITH AMP SOLDERABILITY SPEC. 109-11-3.
- 2. CIRCUIT IDENTIFICATION CHARACTERS ARE ADJACENT TO THE INDICATED CAVITIES, BUT LOCATION AND ORIENTATION MAY DIFFER FROM PRINT.

6	SOCKET	PH BRZ, PRE-TIN	2	643423-1
1	HOUSING	NYLON, 94V-2, NATURAL	1	
	No. PER ASSY	DESCRIPTION	MATERIAL & FINISH	ITEM No. PART NO
UNLESS OTHERWISE SPECIFIED DIMENSIONS ARE IN INCHES. TOLERANCES ON: DECIMALS ± .015 ANGLES 2		CONTRACT NO	AMP INCORPORATED Harrisburg, Pa.	
MATERIAL SEE TABLE		DR D.A. SALTER 3-2-83	NAME: AMP	
FINISH SEE TABLE		CHK: S. No. de 4/7/83	APPROVED: 2/22/86 4/5/83	
		APPROVED: 2/22/86 4/5/83	DRAWING NO: 643423	
		DSGN APPD	SIZE: 13	FSCM NO: 00779
		OTHER APPD	SCALE: 2:1	SHEET: 1