

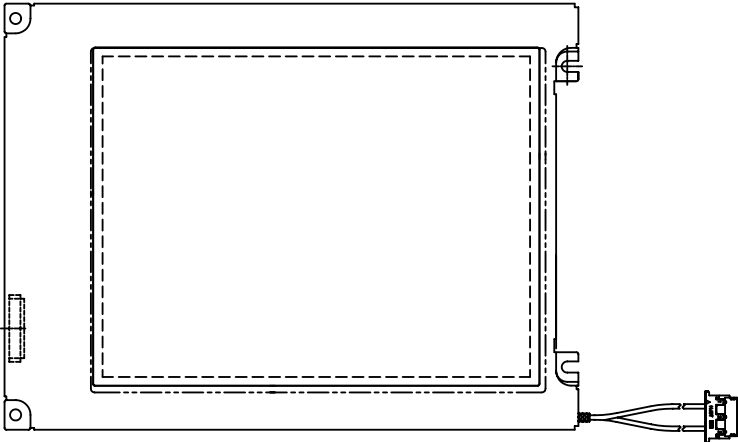

PRODUCT SPECIFICATION

HDM3224-CWL

320 x240 COLOR GRAPHICS
LCD DISPLAY MODULE



HANTRONIX, INC. 10080 BUBB RD. CUPERTINO, CA 95014	Q.A.:	REV:	HDM3224-CWL	SHEET 1 OF 17
	ZW	1.0		DATE: 10/31/05

1. MECHANICAL DATA

NO	ITEM	CONTENTS	UNIT
1	Product No.	HDM3224-CWL	-
2	Module Size	154.6 (W) x 114.8 (H) x 9.0 (D)	mm
3	Dot Size	0.09 (W) x 0.33 (H)	mm
4	Dot Pitch	0.12 (W) x 0.36 (H)	mm
5	Number of Dots	320 x RGB (W) x 240 (H)	Dot
6	Duty	1/240	-
7	LCD Display Mode	FSTN, Color STN Module	-
8	Rear Polarizer	Color Transmission Type	-
9	Viewing Direction	6	O'clock
10	Backlight	LED	-
11	Controller	Excluded	-
12	DC/DC Converter	Excluded	-
13	Weight	195 (Approx.)	g

HANTRONIX, INC. 10080 BUBB RD. CUPERTINO, CA 95014	Q.A.:	REV.:	HDM3224-CWL	SHEET 2 OF 17
	Z.W.	1.0		DATE: 10/31/05

2. ABSOLUTE MAXIMUM RATINGS

(1) ELECTRICAL ABSOLUTE RATINGS

VSS=0V

ITEM	SYMBOL	MIN	MAX	UNIT	COMMENT
Power Supply for Logic	VDD-VSS	-0.3	6.5	V	
Power Supply for LCD Drive	VEE-VSS	0	30	V	
Input Voltage	VI	-0.3	VDD+0.3	V	
Static Electricity	-	-	-	-	Note 1

(2) ENVIRONMENTAL ABSOLUTE MAXIMUM RATINGS

ITEM	WIDE TEMP.			
	OPERATING		STORAGE	
	MIN.	MAX.	MIN.	MAX.
Ambient Temperature	-20	70	-30	80
Humidity (Without Condensation)	Note 2,4		Note 3,4	
Vibration	Note 5			

Note 1 LCM should be grounded during handling LCM.

Note 2 $T_a \leq 70^\circ\text{C}$: 75%RH max

$T_a > 70^\circ\text{C}$: Absolute humidity must be lower than the humidity of 75%RH at 70°C

Note 3 T_a at -30°C will be < 48hrs, at 80°C will be < 120hrs

Note 4 Background color will change slightly depending on ambient temperature. at phenomenon is reversible.

Note 5

Frequency	5 Hz~13.95 Hz	13.95 Hz~33 Hz	33 Hz~51 Hz	51 Hz~500 Hz
Vibration Level	-	2X9.8 m/s ²	-	5x9.8 m/s ²
Vibration Width	0.2 inch	-	0.036 inch	-
Vibration Direction	X/Y/Z			
Vibration Time	20 min/cycle X 3 directions			

HANTRONIX, INC. 10080 BUBB RD. CUPERTINO, CA 95014	Q.A.:	REV.:	HDM3224-CWL	SHEET 3 OF 17
	Z.W.	1.0		DATE: 10/31/05

3. ELECTRICAL CHARACTERISTICS

3-1. ELECTRICAL CHARACTERISTICS OF LCM

Ta=25°C, VDD=3V/5V±5%

ITEM	SYMBOL	CONDITION	MIN.	TYP.	MAX.	UNIT		
Logic Circuit Power Supply	VDD-VSS	Ta= 25°C	4.75	5.0	5.25	V		
Logic Circuit Power Supply	VDD-VSS	Ta= 25°C	2.7	3.0	3.3	V		
Input Voltage	VIH	H level	0.8VDD	-	VDD	V		
	VIL	L level	0	-	0.2VDD	V		
Recommended LCD Driving Voltage	VEE-VSS (Vop)	Duty=1/240 VDD=3V/5V	-20°C	27.0	27.4	27.8	V	
			0°C	26.2	26.6	27.0		
			25°C	25.2	25.6	26.0		
			50°C	24.1	24.5	24.9		
			70°C	23.5	23.9	24.3		
Supply Current for Logic	IDD	VDD-VSS=3V/5V VEE-VSS=25.6V FLM=120Hz Ta=25°C	-	2.0	3.0	mA		
Supply Current for LCD	IEE	PATTERN : ■ □ ■ □ ■ □ ■ □ □ ■ □ ■ □ ■ □ ■	-	4.8	7.2	mA		
LCM	Surface Luminance	L	VEE-VSS =25.6V Ta=25°C Vak=5V	PATTERN: (Dots All On of White Color)	70	-	-	cd/m ²
				PATTERN: (Dots All Off)	-	-	7	
Recommended Frame Frequency for Optimum Contrast		FLM	-	120	140	150	Hz	

HANTRONIX, INC.
10080 BUBB RD.
CUPERTINO, CA 95014

Q.A.:
Z.W.

REV.:
1.0

HDM3224-CWL

SHEET 4 OF 17

DATE: 10/31/05

3-2.ELECTRICAL CHARACTERISTICS OF BACKLIGHT

Used LED Rating

Temp.=25°C

ITEM	SYMBOL	MIN.	TYP.	MAX.	UNIT	REMARK
Peak forward current	I_P	-	-	250	mA	-
Maximum reverse voltage	V_R	-	-	5	V	-
Applied forward current	I_F	-	-	200	mA	at $V_F = 5V$
Applied forward voltage	V_F	-	5	-	V	-
LED power consumption	P_F	-	-	1.25	W	-
LED life time	L_L	-	10000	-	hrs	at $I_F = 200 \text{ mA}$ (*1)

(*1) LED life time is defined as follows : The final brightness is at 50% of original brightness .

HANTRONIX, INC. 10080 BUBB RD. CUPERTINO, CA 95014	Q.A.:	REV.:	HDM3224-CWL	SHEET 5 OF 17
	Z.W.	1.0		DATE: 10/31/05

4.OPTICAL CHARACTERISTICS

4-1.Optical Char. of Wide Temp. Mode

Cr>2 AT Vop

ITEM		Cr(Contrast Ratio)										θ (Viewing Angle)		ϕ (Viewing Angle)	
		-20°C		0°C		25°C		50°C		70°C		25°C		25°C	
MODE		MIN.	TYP.	MIN.	TYP.	MIN.	TYP.	MIN.	TYP.	MIN.	TYP.	MIN.	TYP.	MIN.	TYP.
T	M	12	18	14	20	17	25	3.5	5	1.4	2	-	F: >60 R: 30	-	L: 55 R: 55
NOTE		NOTE 6										NOTE 5			

note:

T: TRANSMISSIVE

M: For 6 O'clock Color STN Module

AT $\phi=0^\circ$ $\theta=0^\circ$

ITEM	SYMBOL	CONDITION	MIN.	TYP.	MAX.	UNIT	NOTE
Response Time (rise)	Tr	-20°C	2300	2900	4300	ms	NOTE 2
		0°C	640	800	1200		
		25°C	240	300	450		
		50°C	80	100	150		
		70°C	45	55	80		
Response Time (fall)	Tf	-20°C	1500	1800	2700	ms	NOTE 2
		0°C	360	450	670		
		25°C	80	100	150		
		50°C	48	60	90		
		70°C	32	40	60		

HANTRONIX, INC. 10080 BUBB RD. CUPERTINO, CA 95014	Q.A.:	REV.:	HDM3224-CWL	SHEET 6 OF 17
	Z.W.	1.0		DATE: 10/31/05

4-2. Color of CIE Coordinate

Ta = 25°C

ITEM		SYMBOL	CONDITION	VALUE	NOTE
Color of CIE Coordinate	Red	X	$\phi=0^\circ, \theta=0^\circ$	0.53	Note*
		y		0.33	
	Green	X	$\phi=0^\circ, \theta=0^\circ$	0.31	
		y		0.52	
	Blue	X	$\phi=0^\circ, \theta=0^\circ$	0.16	
		y		0.12	
	White	X	$\phi=0^\circ, \theta=0^\circ$	0.30	
		y		0.31	

Note* Measuring at position 3 on Fig.1
CIE chromaticity diagram

Tolerance : ± 0.05

Fig.1

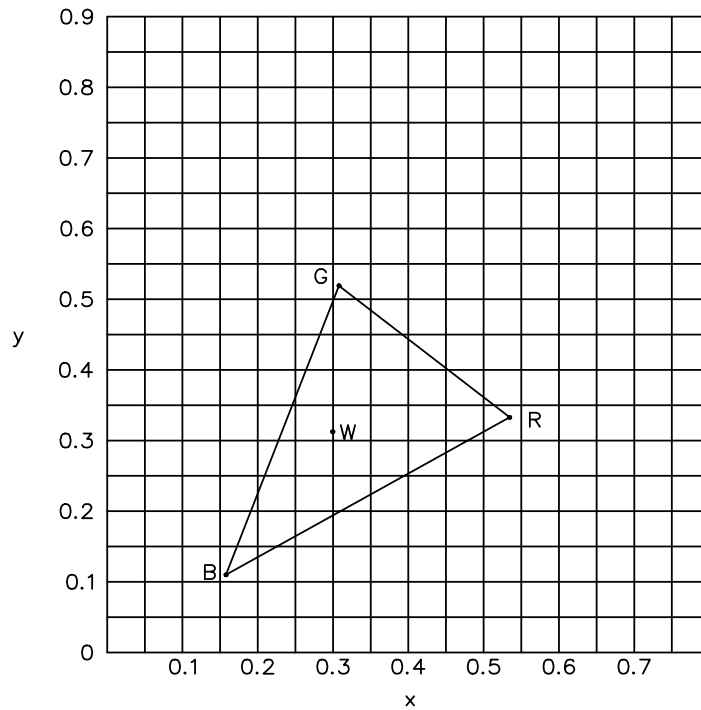

HANTRONIX, INC.
10080 BUBB RD.
CUPERTINO, CA 95014

Q.A.:
Z.W.

REV.:
1.0

HDM3224-CWL

SHEET 7 OF 17

DATE: 10/31/05

(NOTE 1)

Definition of Operation Voltage(Vop)

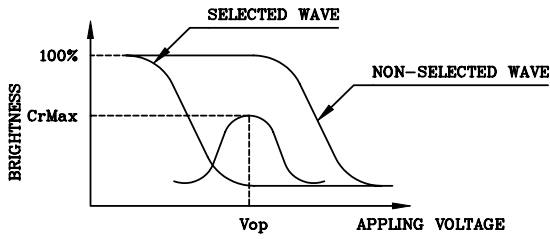

(positive type)

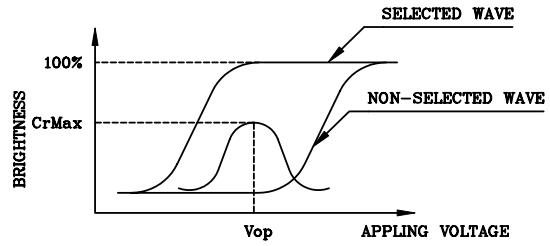

(negative type)

*Conditions

Viewing Angle : 0
 Frame Frequency : 140Hz
 Applying Waveform : 1/N duty 1/a bias

(NOTE 2)

Definition of Response Time(Tr,Tf)

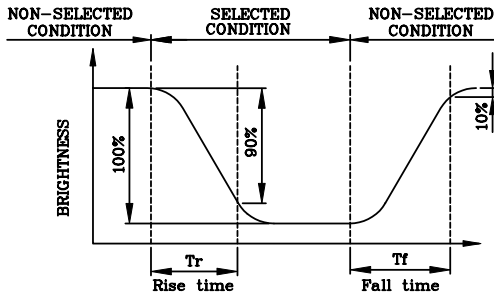

(positive type)

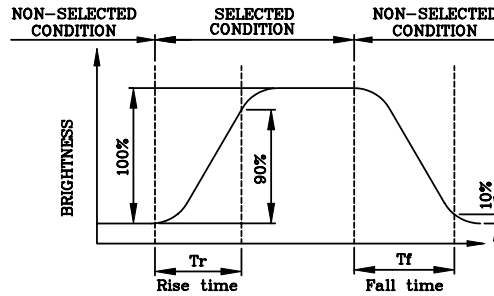

(negative type)

*Conditions

Operating Voltage : Vop
 Viewing Angle (θ,φ) : (0,0)
 Frame Frequency : 140Hz
 Applying Waveform : 1/N duty 1/a bias

(NOTE 3)

Description of Measuring Equipment and Driving Waveforms

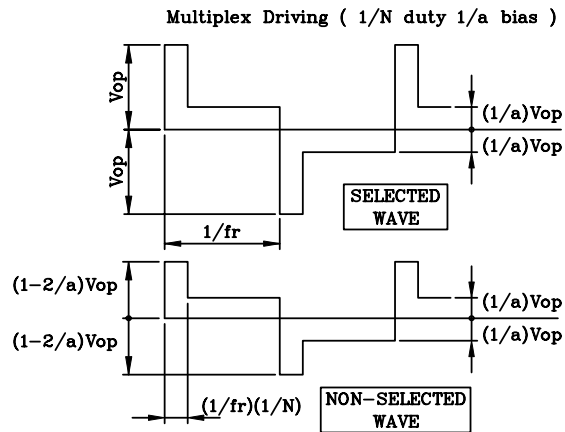
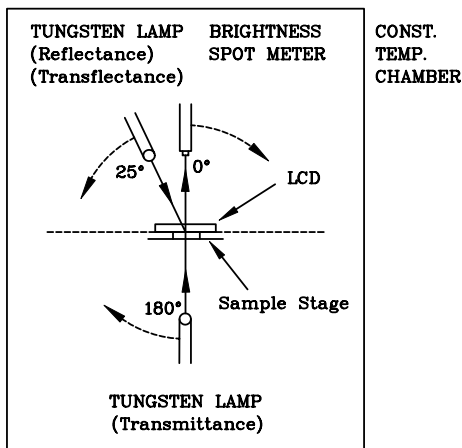

HANTRONIX, INC. 10080 BUBB RD. CUPERTINO, CA 95014	Q.A.:	REV.:	HDM3224-CWL	SHEET 8 OF 17
	Z.W.	1.0		DATE:

(NOTE 4)

Definition of Viewing Direction

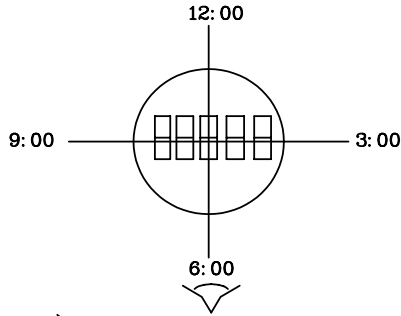

(NOTE 5)

Definition of Viewing Angle

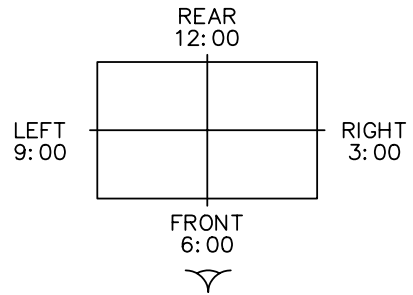
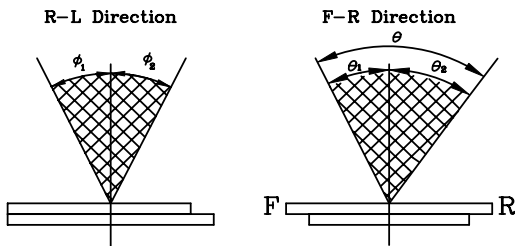

$$\theta = \theta_1 + \theta_2$$

*Conditions

Operating Voltage : V_{op}
 Frame Frequency : 140Hz
 Applying Waveform : 1/N duty 1/a bias
 Contrast Ratio : larger than 2

(NOTE 6)

Definition of Contrast Ratio (Cr)

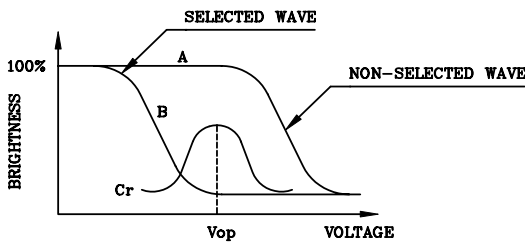

(positive type)

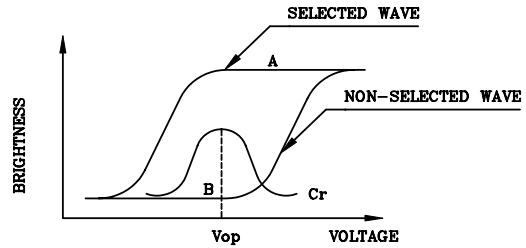

(negative type)

Contrast Ratio : $Cr = A/B$

*Conditions

Viewing Angle : 0
 Frame Frequency : 140Hz
 Applying Waveform : 1/N duty 1/a bias

HANTRONIX, INC. 10080 BUBB RD. CUPERTINO, CA 95014	Q.A.:	REV.:	HDM3224-CWL	SHEET 9 OF 17
	Z.W.	1.0		DATE: 10/31/05

5. BLOCK DIAGRAM

LCD

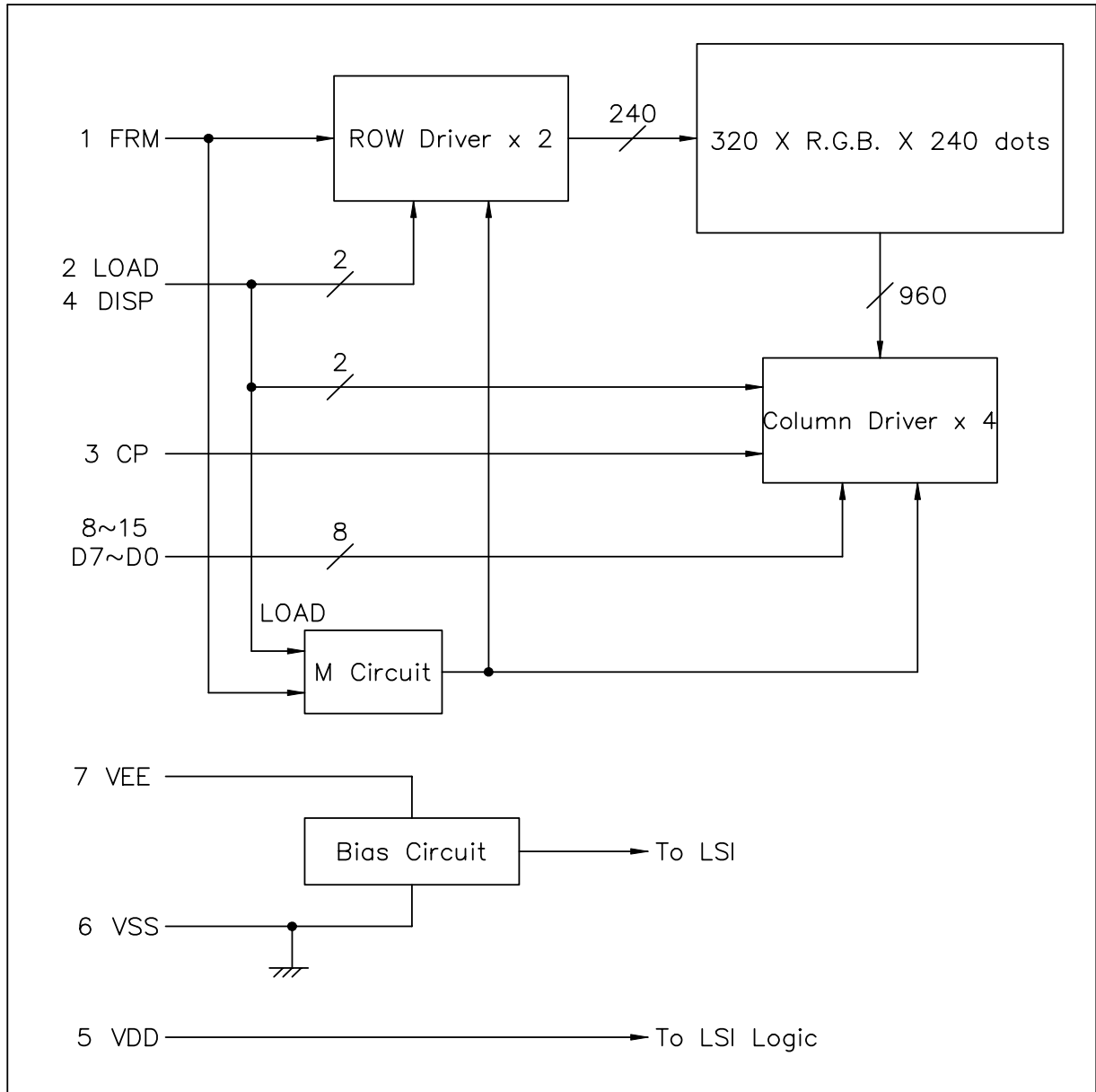

CCFL

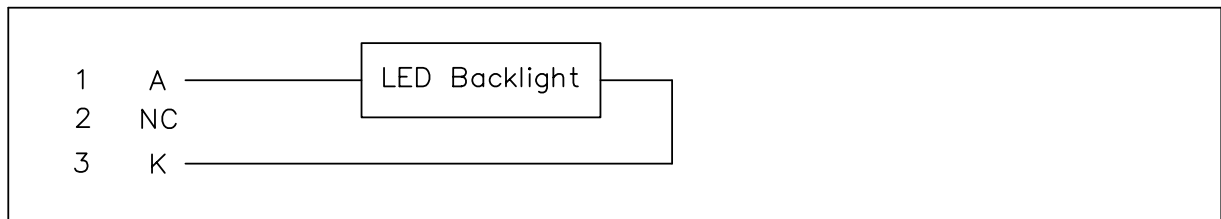

HANTRONIX, INC. 10080 BUBB RD. CUPERTINO, CA 95014	Q.A.:	REV.:	HDM3224-CWL	SHEET 10 OF 17
	Z.W.	1.0		DATE: 10/31/05

6. INTERNAL PIN CONNECTION

LCD

Pin No.	Symbol	Function	Level
1	FRM	Synchronous signal for driving scanning line	H
2	LOAD	Data signal latch clock	H → L
3	CP	Data signal shift clock	H → L
4	DISP	Display control signal	H(ON),L(OFF)
5	VDD	Power supply for logic	—
6	VSS	GND	—
7	VEE	Power supply for LCD	—
8	D7	Display data	H(ON),L(OFF)
9	D6		
10	D5		
11	D4		
12	D3		
13	D2		
14	D1		
15	D0		

CN1 : 53261-1510(Molex)

Recommended Matching Connector : 51021-1500(Molex) or Compatible

LED

Pin No.	Symbol	Function	Level
1	A	Power supply for LED Backlight (+)	—
2	NC	NO Connection	—
3	K	Power supply for LED Backlight (-)	—

CN2 : BHR-03VS-1(JST)

Recommended Matching Connector : SM02-(8.0)B-BHS-1(JST) or Compatible

HANTRONIX, INC. 10080 BUBB RD. CUPERTINO, CA 95014	Q.A.:	REV.:	HDM3224-CWL	SHEET 11 OF 17
	Z.W.	1.0		DATE: 10/31/05

7. POWER SUPPLY

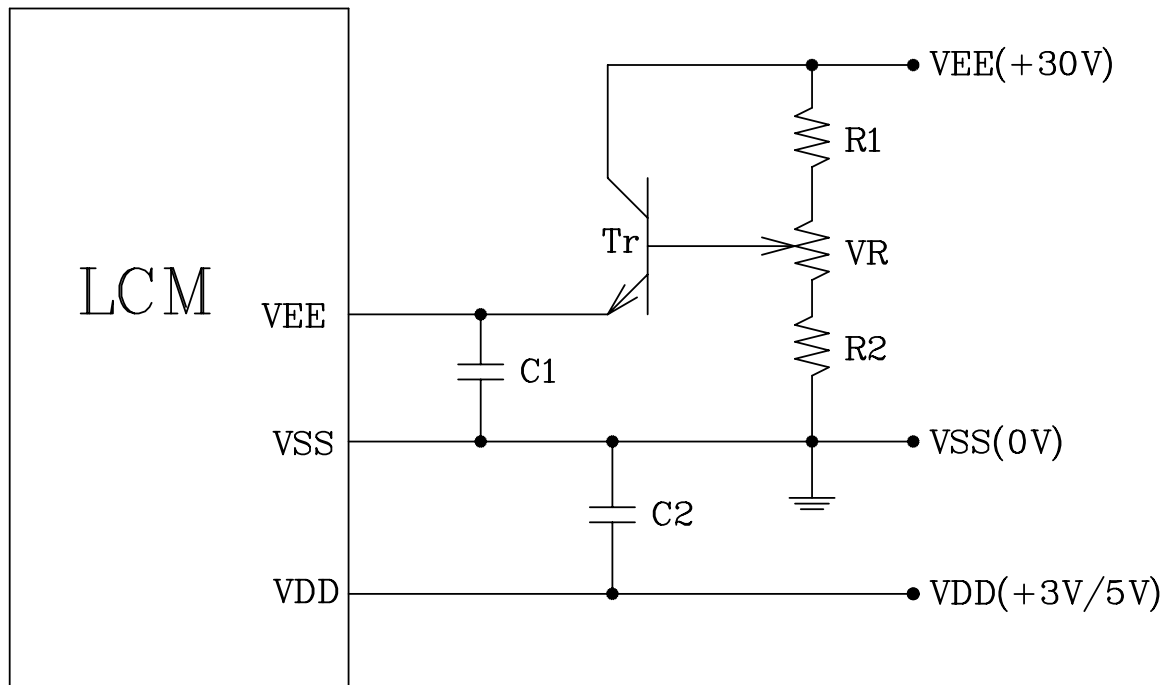

$$R1 + R2 + VR = 10 \sim 20K \Omega$$

$$C1, C2 = 10 \mu F$$

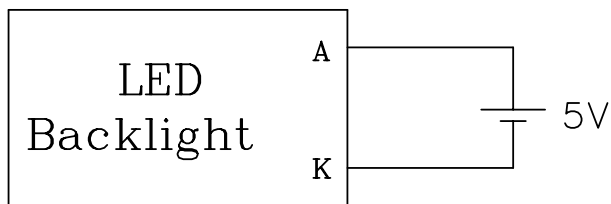

HANTRONIX, INC. 10080 BUBB RD. CUPERTINO, CA 95014	Q.A.:	REV.:	HDM3224-CWL	SHEET 12 OF 17
	Z.W.	1.0		DATE: 10/31/05

8. TIMING CHARACTERISTICS

8-1. INTERFACE TIMING

VDD=3.0/5.0V ± 10%

Parameter	SYMBOL	MIN.	MAX.	UNIT
CLOCK PULSE CYCLE TIME	t_{wck}	66/40	—	ns
CLOCK PULSE HIGH LEVEL WIDTH	t_{wckh}	23/12	—	ns
CLOCK PULSE LOW LEVEL WIDTH	t_{wckl}	23/14	—	ns
LATCH PULSE HIGH LEVEL WIDTH	t_{wlph}	30/15	—	ns
CP→LP RISE TIME	t_{ld}	10/5	—	ns
CP→LP FALL TIME	t_{sl}	30/25	—	ns
LP→CP RISE TIME	t_{ls}	30/25	—	ns
LP→CP FALL TIME	t_{lh}	30/25	—	ns
CLOCK PULSE RISE/FALL TIME	t_r, t_f	—	50	ns
DATA SETUP TIME	t_{ds}	10/5	—	ns
DATA HOLD TIME	t_{dh}	25/15	—	ns
$\overline{\text{DISPOFF}}$ LOW LEVEL WIDTH	t_{wdl}	1.2	—	μs
$\overline{\text{DISPOFF}}$ CANCELLATION TIME	t_{sd}	100	—	ns

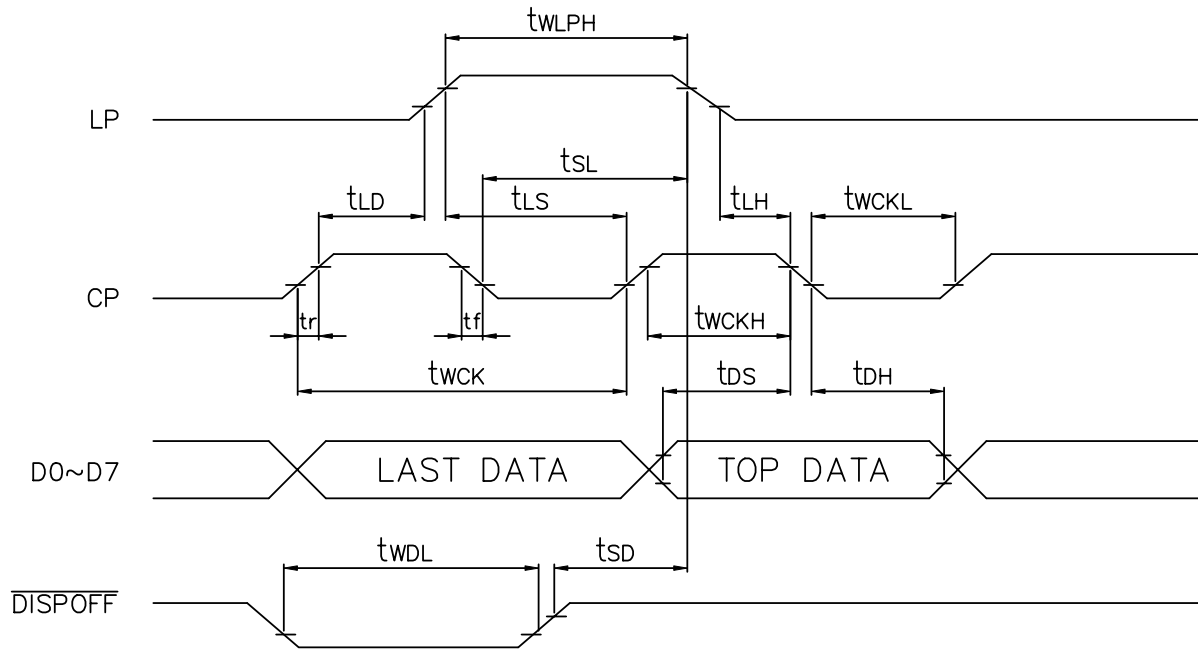

HANTRONIX, INC. 10080 BUBB RD. CUPERTINO, CA 95014	Q.A.:	REV.:	HDM3224-CWL	SHEET 13 OF 17
	Z.W.	1.0		DATE: 10/31/05

8-2. TIMING CHART

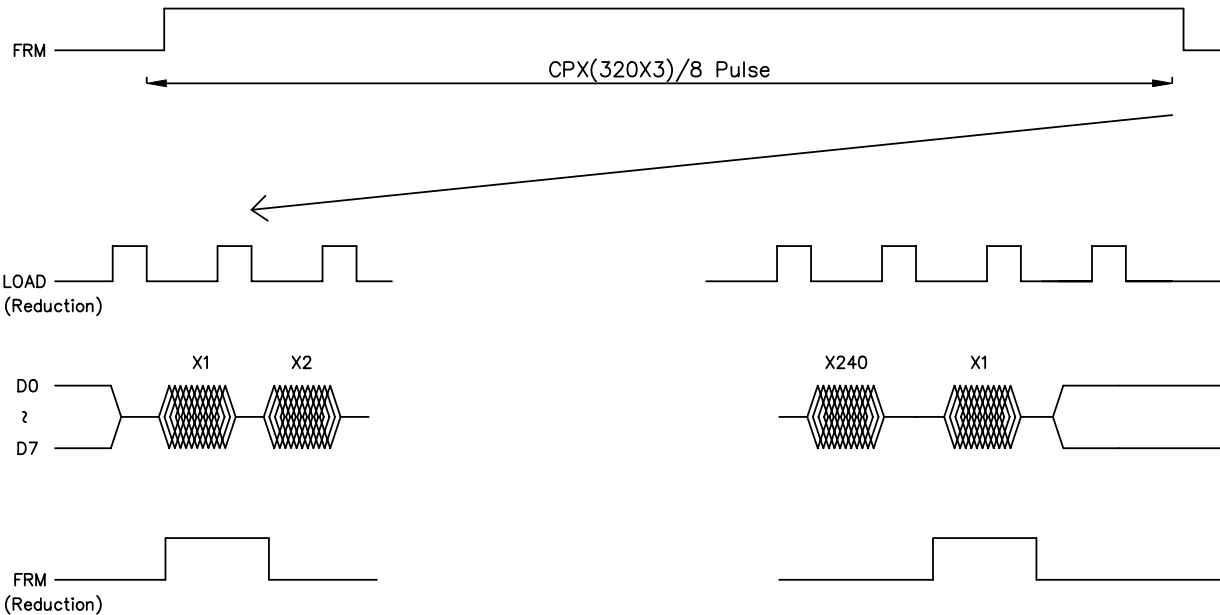
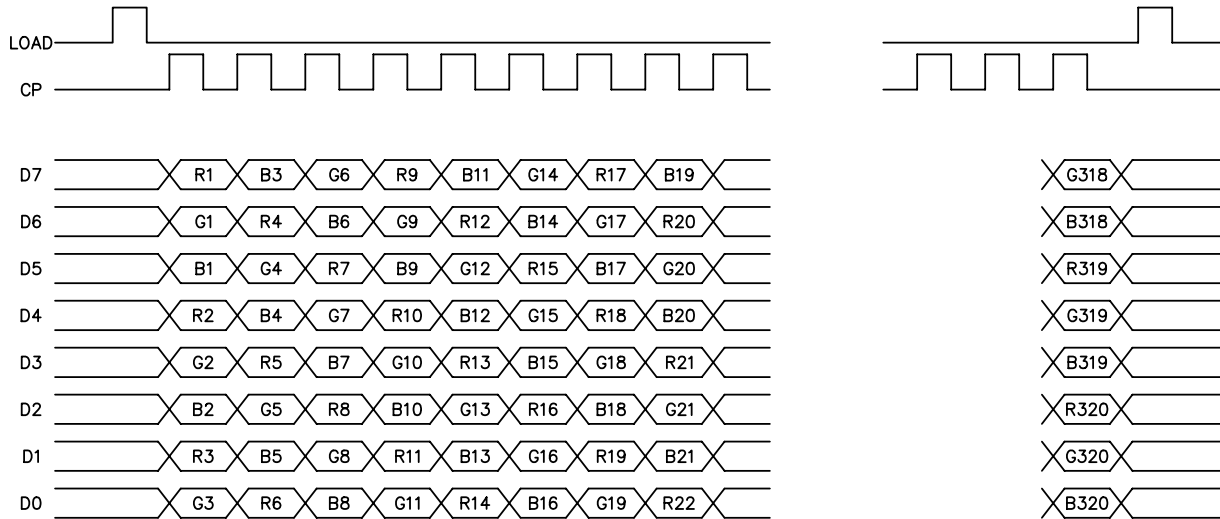

HANTRONIX, INC. 10080 BUBB RD. CUPERTINO, CA 95014	Q.A.:	REV.:	HDM3224-CWL	SHEET 14 OF 17
	Z.W.	1.0		DATE: 10/31/05

8-3. POWER ON/OFF TIMING

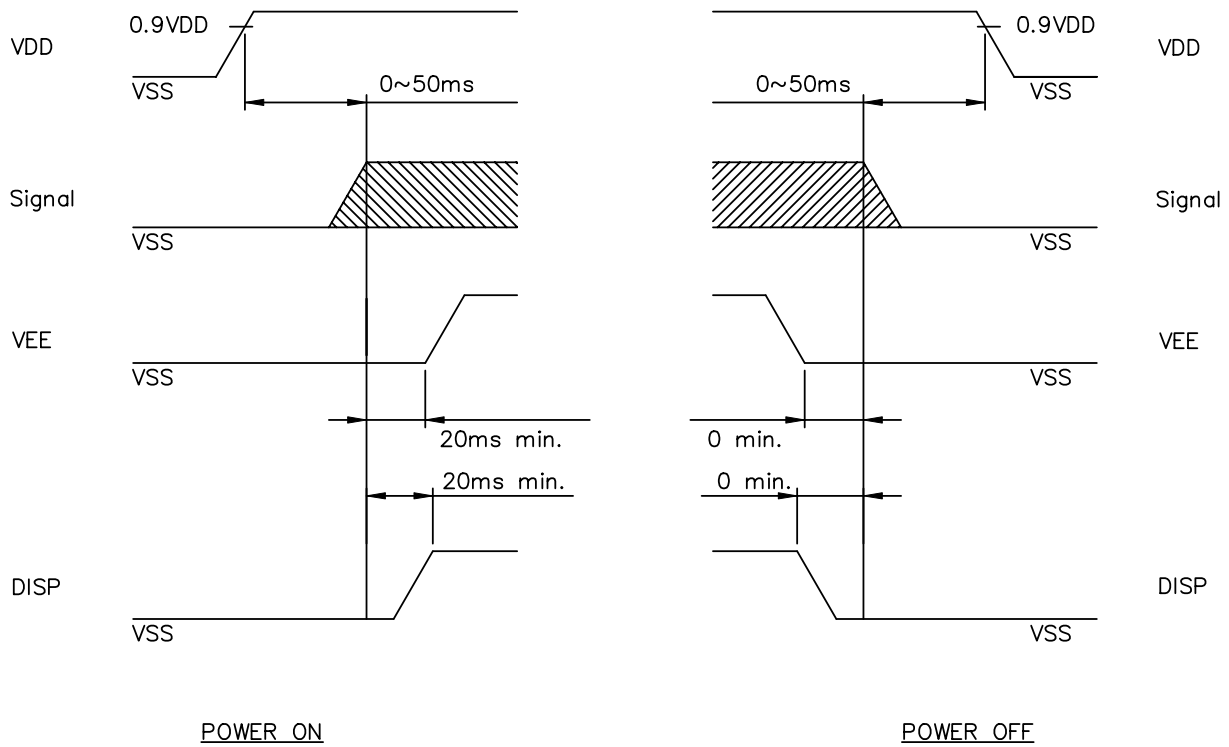

The missing pixels may occur when the LCM is driven beyond above power interface timing sequence.

HANTRONIX, INC. 10080 BUBB RD. CUPERTINO, CA 95014	Q.A.:	REV.:	HDM3224-CWL	SHEET 15 OF 17
	Z.W.	1.0		DATE: 10/31/05

8-4.DISPLAY PATTERN

START DATA

	Y1			Y2			Y3		
x1	R1	G1	B1	R2	G2	B2	R3	G3	B3
	D7	D6	D5	D4	D3	D2	D1	D0	D7
x2	R1	G1	B1	R2	G2	B2	R3	G3	B3
	D7	D6	D5	D4	D3	D2	D1	D0	D7

Y318			Y319			Y320		
R318	G318	B318	R319	G319	B319	R320	G320	B320
D0	D7	D6	D5	D4	D3	D2	D1	D0
R318	G318	B318	R319	G319	B319	R320	G320	B320
D0	D7	D6	D5	D4	D3	D2	D1	D0

x239	R1	G1	B1	R2	G2	B2	R3	G3	B3
	D7	D6	D5	D4	D3	D2	D1	D0	D7
x240	R1	G1	B1	R2	G2	B2	R3	G3	B3
	D7	D6	D5	D4	D3	D2	D1	D0	D7

R318	G318	B318	R319	G319	B319	R320	G320	B320
D0	D7	D6	U5	D4	D3	D2	D1	D0
R318	G318	B318	R319	G319	B319	R320	G320	B320
D0	D7	D6	U5	D4	D3	D2	D1	D0

HANTRONIX, INC.
10080 BUBB RD.
CUPERTINO, CA 95014

Q.A.:
Z.W.

REV.:
1.0

HDM3224-CWL

SHEET 16 OF 17

DATE:
10/31/05

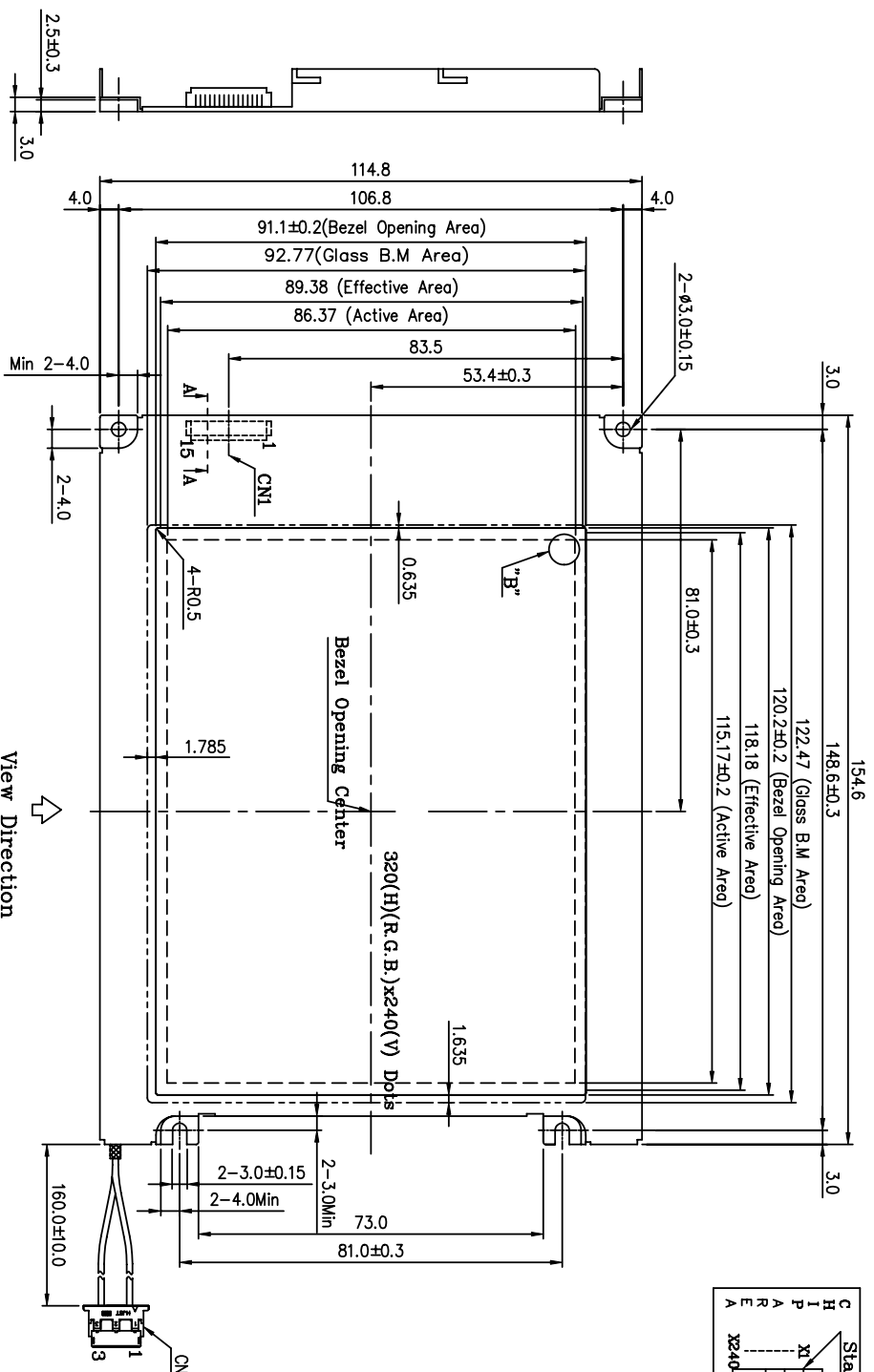

Start		Chip Area																					
C	H	Y1	Y2	Y3	...	Y320	D7	D6	D5	D4	D3	D2	D1	D0	D7	D6	D5	D4	D3	D2	D1	D0	
A	A	R1	G1	B1	R2	G2	B2	R3	G3	B3	...	R320	G320	B320	R320	G320	B320	R320	G320	B320	R320	G320	B320

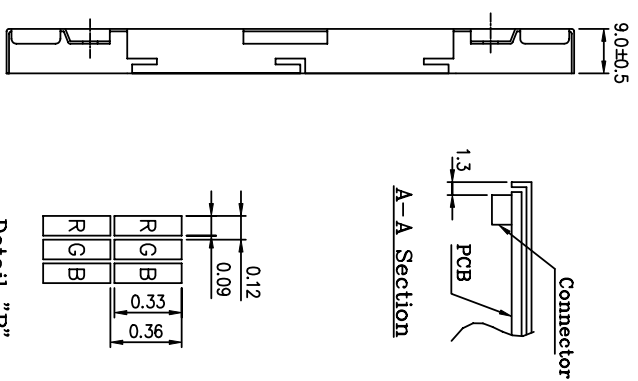

View Direction

CN1 : 53261-1510 (Molex)

Pin No.	Symbol	Function	Level	10	D5
1	FRM	Synchronous signal for driving scanning line	H	11	D4
2	LOAD	Data signal latch clock	H → L	12	D3
3	CP	Data signal shift clock	H → L	13	D2
4	DISP	Display control signal	H(ON),L(OPF)	14	D1
5	VDD	Power supply for logic	-	15	D0
6	VSS	GND	-	CN2 : BHR-03VS-1 (JST)	
7	VEE	Power supply for LCD	-	Pin No.	Symbol
8	D7	Display data	H(ON),L(OPF)	1	A
9	D6			2	NC
				3	K

HANTRONIX

GENERAL TOLERANCE LIST

DIMENSION	TOLERANCE
L ≤ 6	±0.25 (mm)
6 < L ≤ 18	±0.3 (mm)
18 < L ≤ 50	±0.4 (mm)
50 < L ≤ 125	±0.5 (mm)
125 < L	±0.6 (mm)
ANGLE	±1° (DEG)

- Notes :
- Resolution : 320(H)(R.G.B) x 240(V) Dots
 - Backlight : LED (White)
 - Frame Material : SECC (t=0.5)

REV. NO.	DESCRIPTION	DATE	DESIGN	CHECK	APPROVE	DWG NO.
△						HDM3224-CW1
△						
△						