

LIQUID CRYSTAL DISPLAY MODULE

L4044

PRODUCT SPECIFICATION

SEIKO INSTRUMENTS INC.

L4044

■ Features of L4044 Series

- 40 characters × 4 lines
- STN LCD is used
- 5 × 7 dot matrix + cursor
- 1/16 duty
- 5V single power supply

■ Specification

A. Mechanical Characteristics

Item	Specifications	Unit
Module size (H×V×T) (Reflective type)	190.0×54.0×10.1	mm
Module size (H×V×T) (Built-in LED backlight type)	190.0×54.0×16.3	mm
Module size (H×V×T) (Built-in EL backlight type)	190.0×54.0×11.3	mm
Viewing area (H×V)	147.0×29.5	mm
Character size (5×7 dot, H×V)	2.78×4.27	mm
Dot size (H×V)	0.50×0.55	mm
Dot space	0.07	mm
Center to center dimension of mounting holes (H×V)	183.0×47.0	mm
Weight (Reflective type)	90	g
Weight (Built-in LED backlight type)	140	g
Weight (Built-in EL backlight type)	105	g

H : Horizontal, V : Vertical, T : Thickness (max.)

B. Absolute Maximum Ratings

$V_{SS} = 0V$

Item	Symbol	Conditions	Min.	Max.	Unit
Power supply voltage	V_{DD}		-0.3	6.0	V
	V_{LC}		$V_{DD}-12.0$	V_{DD}	V
Input voltage	V_{IN}		-0.3	$V_{DD}+0.3$	V
Operating temp.	T_{opr}		0	+50	°C
Storage temp.	T_{stg}		-20	+60	°C
Storage humidity		≤48hrs	+20	+85	%RH
		≤1000hrs	+20	+65	%RH

C. Electrical Characteristics

$V_{DD} = 5V \pm 5\%$, $V_{SS} = 0V$, $T_a = 0^\circ C$ to $50^\circ C$

Item	Symbol	Conditions	Min.	Typ.	Max.	Unit
Power supply voltage	V_{DD}		4.75	5.00	5.25	V
	$V_{DD}-V_{LC}$		4.0	—	11.0	V
Input voltage *	High	V_{IH1}	2.2	—	V_{DD}	V
	Low	V_{IL1}	0	—	0.6	V
Output voltage **	High	V_{OH1}	- $I_{OH} = 0.205mA$	—	—	V
	Low	V_{OL1}	$I_{OL} = 1.2mA$	—	—	0.4
Current consumption	I_{DD}	$T_a = 25^\circ C$ $V_{DD} = 5V$ $V_{LC} = 0.25V$	—	8.0	12.0	mA
	I_{LC}		—	3.8	4.5	mA
Clock oscillation frequency	f_{osc}	Resistance oscillation	190	270	350	kHz

* Applied to DB0 ~ DB7, E, R/W, RS

** Applied to DB0 ~ DB7

D. Optical Characteristics (STN gray type)

D-1 Reflective type

Viewing angle : 6 o'clock ($\theta = 0^\circ$), $T_a = 25^\circ C$, $V_{opr} = 4.75V$

Item	Symbol	Conditions	Min.	Typ.	Max.	Unit
Viewing angle	θ_1	$C \geq 2.0$ $\theta = 0^\circ$	—	—	-15	deg.
	θ_2		55	—	—	
	$\theta_2 - \theta_1$		70	—	—	
Contrast	C	$\theta = 25^\circ$, $\theta = 0^\circ$	2	4	—	—
Response time (rise)	t_{on}	$\theta = 0^\circ$ $\theta = 0^\circ$	—	270	400	ms
Response time (fall)	t_{off}		—	60	100	
Response time (rise)	t_{on}	$\theta = 0^\circ$, $\theta = 0^\circ$ $T_a = 0^\circ C$ $V_{opr} = 5.0V$	—	720	1100	ms
Response time (fall)	t_{off}		—	170	350	

D-2 Transflective type

Viewing angle : 6 o'clock ($\theta = 0^\circ$), $T_a = 25^\circ C$, $V_{opr} = 4.75V$, Backlight OFF

Item	Symbol	Conditions	Min.	Typ.	Max.	Unit
Viewing angle	θ_1	$C \geq 2.0$ $\theta = 0^\circ$	—	—	-10	deg.
	θ_2		50	—	—	
	$\theta_2 - \theta_1$		60	—	—	
Contrast	C	$\theta = 25^\circ$, $\theta = 0^\circ$	2	4	—	—
Response time (rise)	t_{on}	$\theta = 0^\circ$ $\theta = 0^\circ$	—	270	400	ms
Response time (fall)	t_{off}		—	60	100	
Response time (rise)	t_{on}	$\theta = 0^\circ$, $\theta = 0^\circ$ $T_a = 0^\circ C$ $V_{opr} = 5.0V$	—	720	1100	ms
Response time (fall)	t_{off}		—	170	350	

E. Recommended Operating Voltage (STN gray type)

The recommended value of (V_{opr}) for an ambient temperature is as follows.

$V_{opr} = V_{DD}-V_{LC}$

Temperature (°C)	0	25	50
V_{opr} (V)	5.00	4.75	4.50

■ STN Reflective type

Item	L404400J000
Mechanical Characteristics	A
Absolute Maximum Ratings	B
Electrical Characteristics	C
Optical Characteristics	D-1
Recommended Operating Voltage	E

F-1 Power Supply

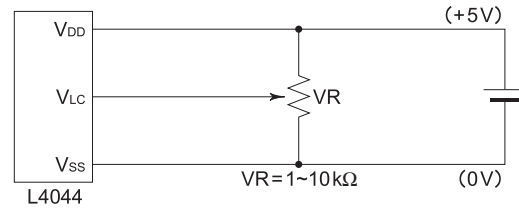

F-2 Dimensions

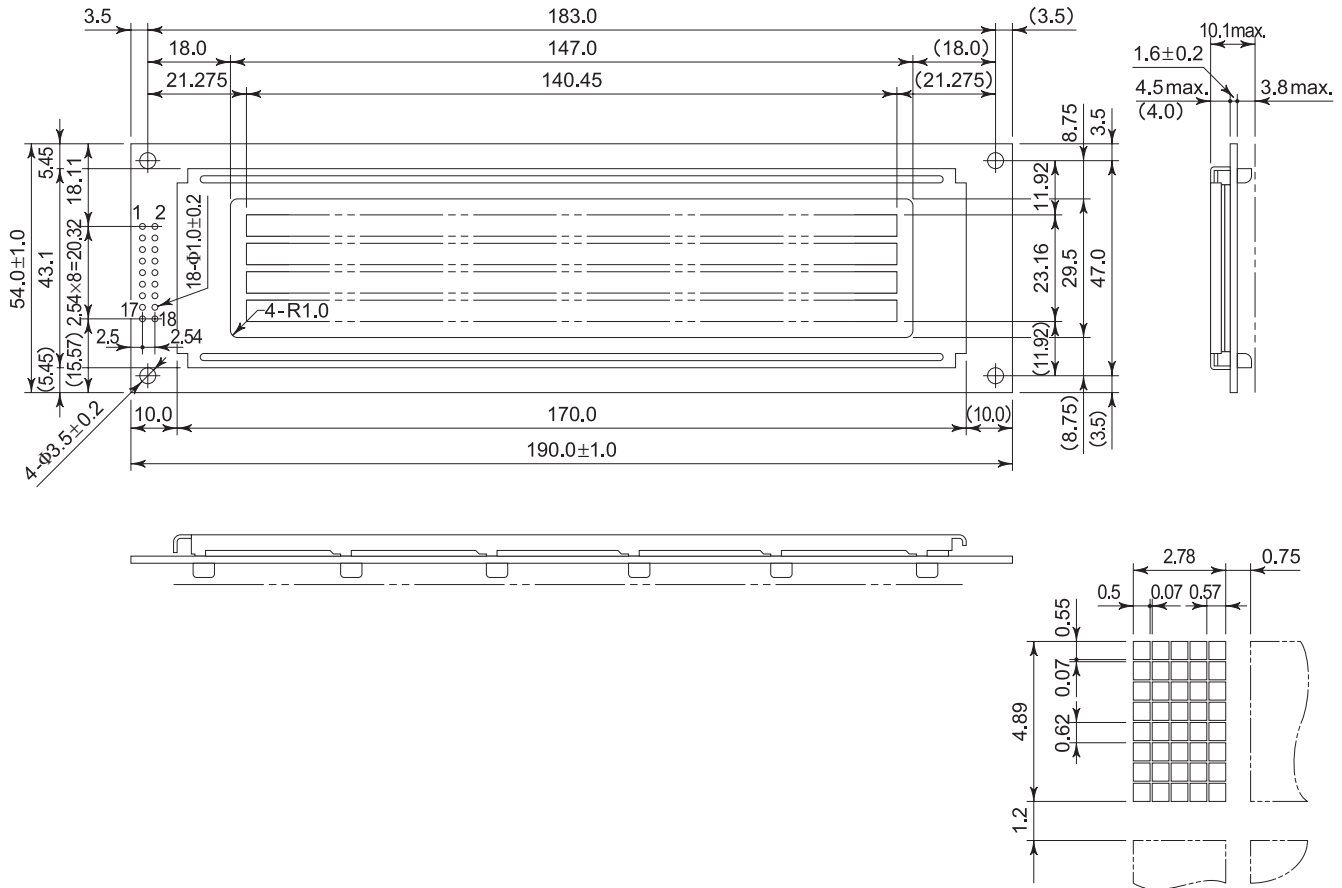

F-3 Pin Functions

No.	Name	Function
1	DB ₇	Data bus line
2	DB ₆	Data bus line
3	DB ₅	Data bus line
4	DB ₄	Data bus line
5	DB ₃	Data bus line
6	DB ₂	Data bus line
7	DB ₁	Data bus line
8	DB ₀	Data bus line
9	E ₁	Enable (for upper 2 lines)
10	R/W	L : Data write (LCM→MPU), H : Data read (LCM→MPU)
11	RS	L : Instruction code input, H : Data input
12	V _{LC}	Liquid crystal driving voltage
13	V _{SS}	GND
14	V _{DD}	Power supply voltage +5V
15	E ₂	Enable (for lower 2 lines)
16	NC	—
17	NC	—
18	NC	—

F-4 Block Diagram

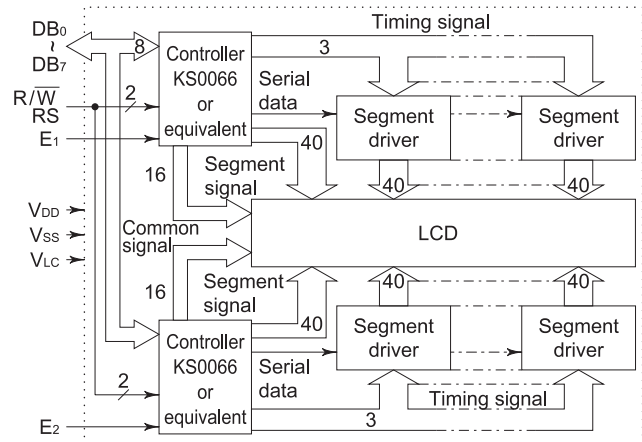

L4044

■ STN Transflective, Built-in LED Backlight type

Item	L4044B1J000
Mechanical Characteristics	A
Absolute Maximum Ratings	B
Electrical Characteristics	C
Optical Characteristics	D-2
Recommended Operating Voltage	E

G-1 Power supply

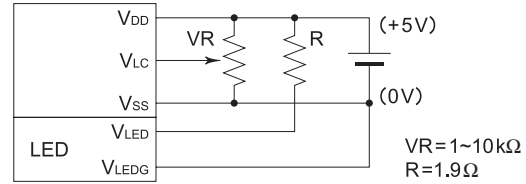

G-2 Dimensions

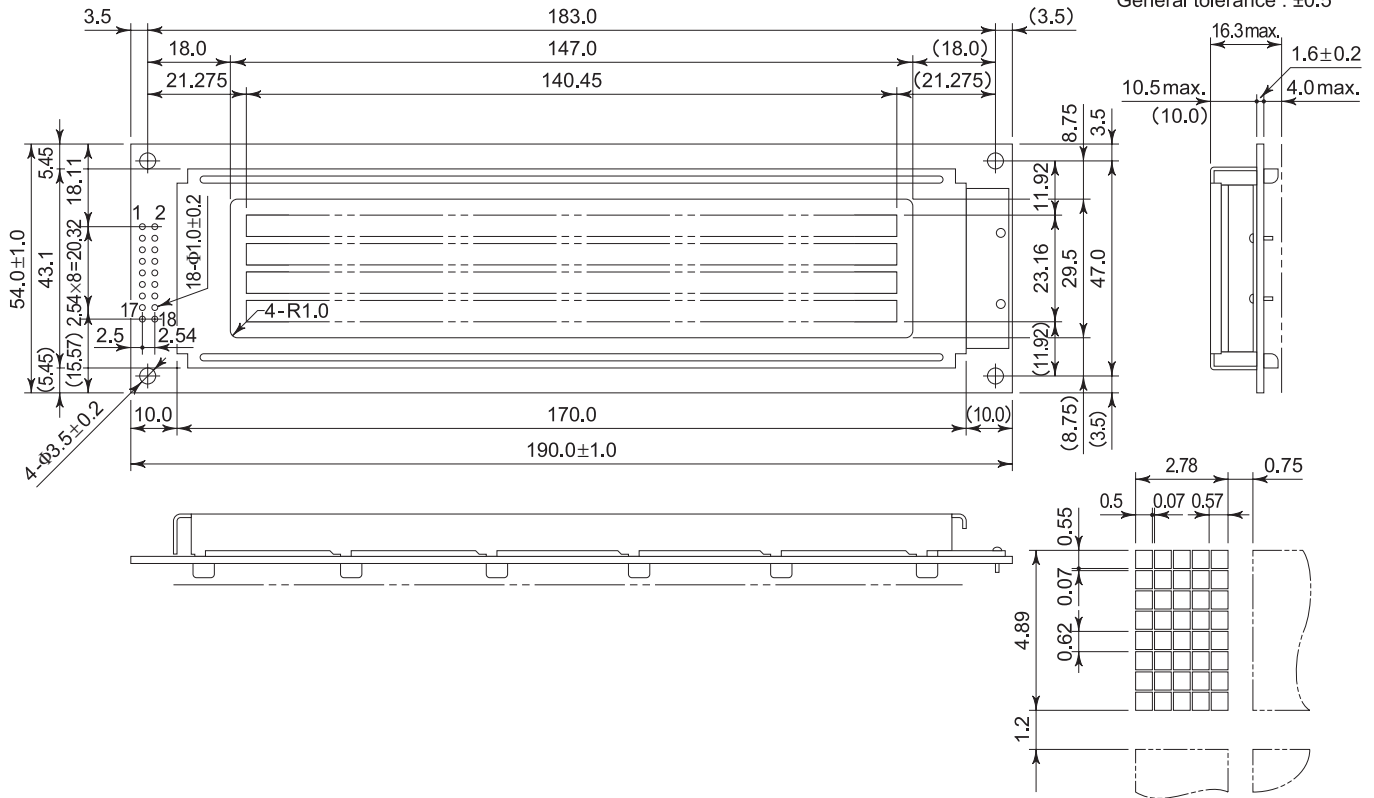

G-3 Pin Functions

No.	Name	Function
1	DB ₇	Data bus line
2	DB ₆	Data bus line
3	DB ₅	Data bus line
4	DB ₄	Data bus line
5	DB ₃	Data bus line
6	DB ₂	Data bus line
7	DB ₁	Data bus line
8	DB ₀	Data bus line
9	E ₁	Enable (for upper 2 lines)
10	R/W	L : Data write (LCM→MPU), H : Data read (LCM→MPU)
11	RS	L : Instruction code input, H : Data input
12	V _{LC}	Liquid crystal driving voltage
13	V _{SS}	GND
14	V _{DD}	Power supply voltage +5V
15	E ₂	Enable (for lower 2 lines)
16	NC	—
17	V _{LED}	Anode
18	V _{LEDG}	Cathode

G-4 Block Diagram

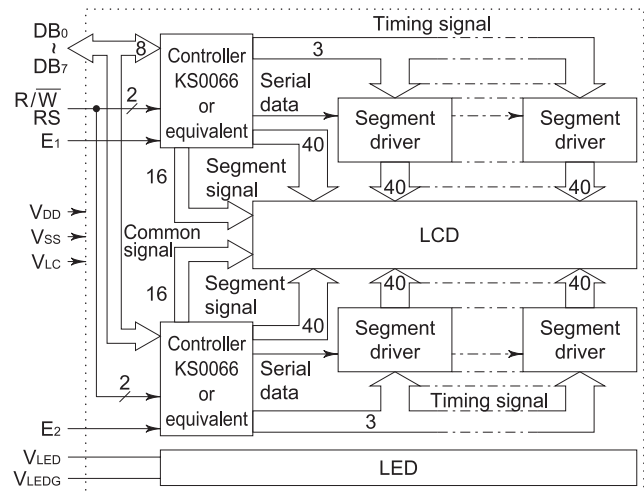

G-5 LED Backlight

G-5-1 LED Circuit Diagram

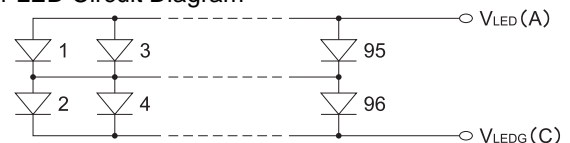

G-5-2 Absolute Maximum Ratings

Ta = 25°C

Item	Symbol	Specifications	Unit
LED forward current consumption*	IF	960	mA
LED reverse voltage	VR	8	V
LED allowable dissipation	PD	4.16	W

* LED forward current consumption and operating temperature characteristics are as follows.

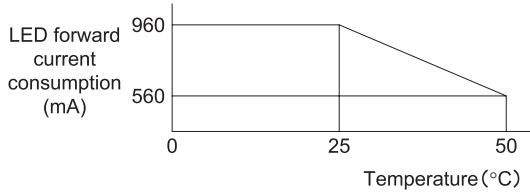

G-5-3 Electrical Characteristics

Ta = 25°C

Item	Symbol	Conditions	Min.	Typ.	Max.	Unit
LED forward input voltage	VF	IF = 480mA	3.8	4.1	4.4	V
LED reverse current	IR	VR = 8V	—	—	4.8	mA

G-5-4 Optical Characteristics

Ta = 25°C

Item	Symbol	Conditions	Specifications	Unit
Surface brightness (panel upper side)	Bp	IF = 480mA Vopr = 0V	8 min. 10 typ.	cd/m ²
LED brightness	L	IF = 480mA	40 min. 50 typ.	cd/m ²
LED service life			50,000 typ.	h
LED color			Yellowgreen	

■ STN Transflective, Built-in EL Backlight type

Item	L404421J000
Mechanical Characteristics	A
Absolute Maximum Ratings	B
Electrical Characteristics	C
Optical Characteristics	D-2
Recommended Operating Voltage	E

H-1 Power Supply

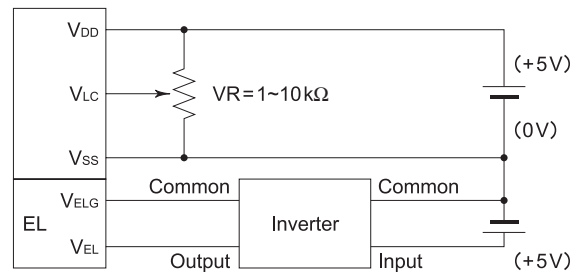

H-2 Dimensions

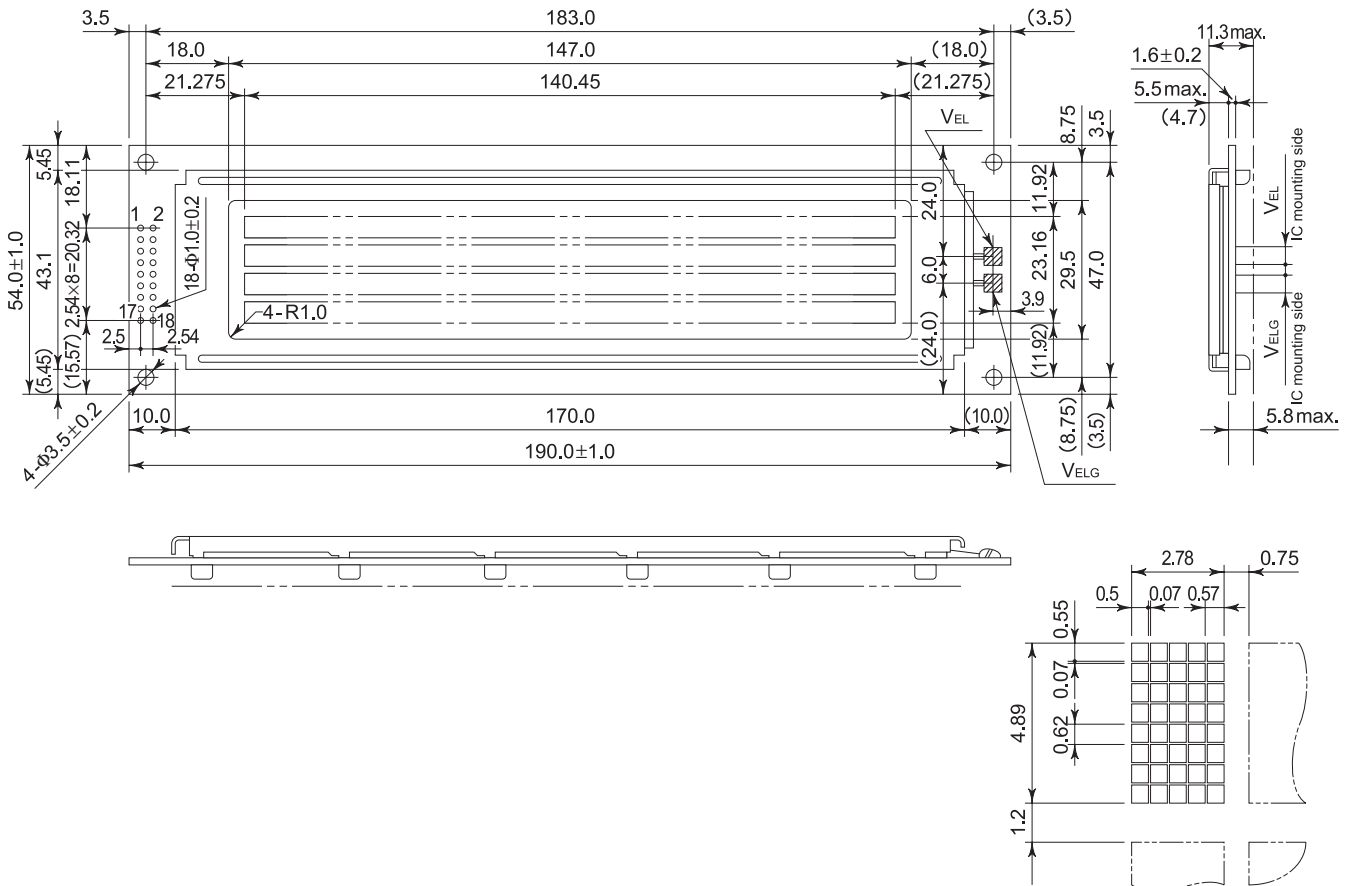

L4044

H-3 Pin Functions

No.	Name	Function
1	DB ₇	Data bus line
2	DB ₆	Data bus line
3	DB ₅	Data bus line
4	DB ₄	Data bus line
5	DB ₃	Data bus line
6	DB ₂	Data bus line
7	DB ₁	Data bus line
8	DB ₀	Data bus line
9	E ₁	Enable (for upper 2 lines)
10	R/W	L : Data write (LCM→MPU), H : Data read (LCM→MPU)
11	RS	L : Instruction code input, H : Data input
12	V _{LC}	Liquid crystal driving voltage
13	V _{SS}	GND
14	V _{DD}	Power supply voltage +5V
15	E ₂	Enable (for lower 2 lines)
16	NC	—
17	NC	—
18	NC	—

H-4 Block Diagram

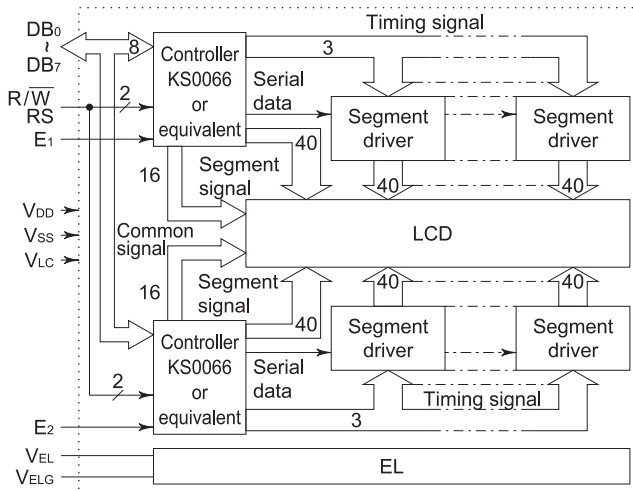

H-5 EL Lamp (white)

H-5-1 Environmental Characteristics

Item	Symbol	Conditions	Specifications
Operating temperature range	T _{opr}		-20°C to +50°C
Storage temperature range	T _{stg}		-20°C to +60°C
Soldering heat-resistance		270°C ± 5°C, 3 s max.	No terminal abnormality
Thermal shock		-20°C 30 min. ↔ +60°C 30 min. 5 cycles	No defect on appearance

H-5-2 Electrical Characteristics

Item	Symbol	Conditions	Spec.	Unit
Electrostatic capacity	C _{EL}	f = 1 kHz (in darkroom) 2 VAC	14.0 typ.	nF
Current	I _{EL}	When applying rated voltage, 20°C, 70%RH	8.0 max. 5.8 typ.	mA
Maximum rated voltage	V _{EL1}	Sine wave, 1 kHz	150	Vrms
Rated voltage	V _{EL2}	Sine wave, 400 Hz	100	Vrms
Isolation voltage		Between lead and film Sine wave, 50 Hz, 1 min.	1500	Vrms

H-5-3 Emission Characteristics

Item	Conditions	Specifications	Unit
Initial brightness (B)	When applying rated voltage 20°C, 70%RH(in darkroom)	30 min. 35 typ.	cd/m ²
Service life when applying rated voltage	Used continuously down to half of initial brightness 20°C, 70%RH	1500	h
Service life when used with an inverter	Used continuously down to half of initial brightness 20°C, 70%RH	4000	h
Color of light		White	—
Chromaticity coordinates	When applying rated voltage 20°C, 70%RH (in darkroom)	x = 0.315 typ. y = 0.375 typ. x = 0.285 min. y = 0.345 min. x = 0.355 max. y = 0.415 max.	—

H-6 Suitable Inverter 5D

H-6-1 Electrical Characteristics (when combined with EL lamp)

Item	Symbol	Conditions	Specifications	Unit
Oscillating frequency	f _{INV}	T _a = 25°C, V _{IN} = 5 VDC	350 typ.	Hz
Output voltage	V _{OUT}	T _a = 25°C, V _{IN} = 5 VDC	130 typ.	V
Output current	I _{OUT}	T _a = 25°C, V _{IN} = 5 VDC	5.5 typ.	mA
Input current	I _{IN}	T _a = 25°C, V _{IN} = 5 VDC	80 typ.	mA
Input voltage	V _{IN}		5 typ.	V DC
Initial brightness	B	T _a = 25°C, V _{IN} = 5 VDC	45 typ.	cd/m ²
Surface brightness (panel upper side)	B _p	T _a = 25°C, V _{IN} = 5 VDC V _{opr} = 0V	9 typ.	cd/m ²

H-6-2 Tolerance (inverter only)

Item	Specifications	Unit
Input voltage	3.0 to 6.0	V
Load range	35 to 60	cm ²

H-6-3 Maximum ratings (inverter only)

Item	Specifications	Unit
Input voltage	7.0	V
Load range	50	cm ²
Operating temperature range	-10 to +60	°C
Storage temperature range	-20 to +70	°C

H-6-4 Dimensions (Unit : mm)

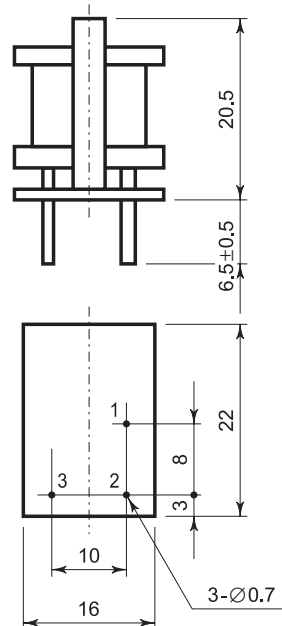

Pin No.	Functions
1	Input : 5V DC
2	Common : GND
3	Output

Wide Temperature Range STN LCD Module**■ Specification****J. Absolute Maximum Ratings**V_{SS} = 0V

Item	Symbol	Conditions	Min.	Max.	Unit
Power supply voltage	V _{DD}		-0.3	6.0	V
	V _{LC}		V _{DD} -12.0	V _{DD}	V
Input voltage	V _{IN}		-0.3	V _{DD} +0.3	V
Operating temp.	T _{opr}		-20	+70	°C
Storage temp.	T _{stg}		-30	+80	°C
Storage humidity		≤48hrs	+20	+85	%RH
		≤1000hrs	+20	+65	%RH

K. Electrical CharacteristicsV_{DD} = 5V ± 5%, V_{SS} = 0V, Ta = -20°C to +70°C

Item	Symbol	Conditions	Min.	Typ.	Max.	Unit
Power supply voltage	V _{DD}		4.75	5.00	5.25	V
	V _{DD} -V _{LC}		4.0	—	11.0	V
Input voltage *	High	V _{IH1}	2.2	—	V _{DD}	V
	Low	V _{IL1}	0	—	0.6	V
Output voltage **	High	V _{OH1}	-I _{OH} = 0.205mA	2.4	—	V
	Low	V _{OL1}	I _{OL} = 1.2mA	—	0.4	V
Current consumption	I _{DD}	Ta = 25°C V _{DD} = 5V V _{LC} = 0.2V	—	8.0	12.0	mA
	I _{LC}		—	3.8	4.5	mA
Clock oscillation frequency	f _{osc}	Resistance oscillation	190	270	350	kHz

* Applied to DB₀ ~ DB₇, E, R/W, RS** Applied to DB₀ ~ DB₇**L. Optical Characteristics**

The background color is affected by ambient temperature, and the response characteristics deteriorates at low temperature.

• Reflective/transflective typeViewing angle : 6 o'clock (∅ = 0°), Ta = 25°C, V_{opr} = 4.8V, Backlight OFF

Item	Symbol	Conditions	Min.	Typ.	Max.	Unit
Viewing angle	∅ ₁	C ≥ 2.0 ∅ = 0°	—	—	0	deg.
	∅ ₂		50	—	—	
	∅ ₂ - ∅ ₁		50	—	—	
Contrast	C	∅ = 20°, ∅ = 0°	2	3	—	—
Response time (rise)	t _{on}	∅ = 0°	—	50	80	ms
Response time (fall)	t _{off}	∅ = 0°	—	100	160	
Response time (rise)	t _{on}	∅ = 0°, ∅ = 0° Ta = 0°C	—	200	320	ms
Response time (fall)	t _{off}	V _{opr} = 4.9V	—	450	720	
Response time (rise)	t _{on}	∅ = 0°, ∅ = 0° Ta = -20°C	—	1500	2400	ms
Response time (fall)	t _{off}	V _{opr} = 5.0V	—	1500	2400	

M. Recommended Operating Voltage

The recommended value of (V_{opr}) for an ambient temperature is as follows.

V_{opr} = V_{DD}-V_{LC}

Temperature (°C)	-20	0	25	70
V _{opr} (V)	5.0	4.9	4.8	4.2

■ Reflective type

Item	L404400P00
Mechanical Characteristics	A
Absolute Maximum Ratings	J
Electrical Characteristics	K
Optical Characteristics	L
Recommended Operating Voltage	M
Reflective type	
Power Supply	F-1
Dimensions	F-2
Pin Functions	F-3
Block Diagram	F-4

■ Built-in LED Backlight type

Item	L4044B1P00
Mechanical Characteristics	A
Absolute Maximum Ratings	J
Electrical Characteristics	K
Optical Characteristics	L
Recommended Operating Voltage	M
Transflective Built-in LED Backlight type	
Dimensions	G-2
Pin Functions	G-3
Block Diagram	G-4
LED Circuit Diagram	G-5-1
Electrical Characteristics (LED)	G-5-3

P. LED Backlight**P-1 Absolute Maximum Ratings**

Ta = 25°C

Item	Symbol	Specifications	Unit
LED forward current consumption *	I _F	960	mA
LED reverse voltage	V _R	8	V
LED allowable dissipation	P _D	4.16	W

* LED forward current consumption and operating temperature characteristics are as follows.

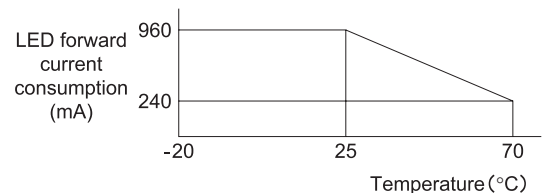
**P-2 Optical Characteristics**

Ta = 25°C

Item	Symbol	Conditions	Specifications	Unit
Surface brightness (panel upper side)	B _p	I _F = 480mA* V _{opr} = 0V	4 min. 5 typ.	cd/m ²
LED brightness	L	I _F = 480mA*	40 min. 50 typ.	cd/m ²
LED service life			50,000 typ.	h
LED color			Yellowgreen	

* The forward current depends upon the temperature. Especially, it must be decreased at high temperature. For temperature dependence, refer to forward current reduction characteristics.

1. PRECAUTIONS

1.1 Handling the LCD Module

Safety

- If the LCD panel is damaged, be careful not to get the liquid crystal in your mouth and not to be injured by crushed glasses.
- If you should swallow the liquid crystal, first, wash your mouth thoroughly with water, then ; drink a lot of water and induce vomiting ; and then, consult a physician.
- If the liquid crystal should get in your eye, flush your eye with running water for at least fifteen minutes.
- If the liquid crystal touches your skin or clothes, remove it and wash the affected part of your skin or clothes with soap and running water.
- High voltage is applied to the lead terminals of the EL lamp. Do not touch any part of the lead terminals. (For LCD modules with EL backlight)
- Do not use EL inverters without a load or in the short-circuit mode.
- Use the LCD module within the rated voltage to prevent overheating and/or damage. Also, take steps to ensure that the connector does not come off.

Handling

- Avoid static electricity, as it may damage CMOS LSIs mounted on the module..
- Since the LCD panel has glass substrate, avoid applying mechanical shock or pressure on the module. Do not drop, bend, twist or press the module.
- Do not disassemble the module.
- Since the polarizer is made of easily-scratched material, be careful not to touch or place objects on the display surface.

- Keep the display surface clean. Do not touch it with your skin.

Mounting and design

- Use the specified mounting parts and holes to mount the module.
- Make sure that no stress is applied on the module when it is mounted ; stress applied for a long time may damage the LCD panel and the IC substrates.
- Connect a 10- μ F capacitor between the power supply terminals to eliminate noise.
- To protect the polarizer and the LCD panel, cover the display surface with a transparent plate (e.g., acrylic or glass) with a small gap between the transparent plate and the display surface.

✧ Example

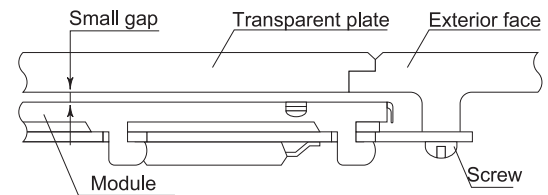

- Do not apply input signals when power supply voltage is not applied.
- Avoid condensation, or the transparent electrodes may break. Use the module within the specified temperature range.

Storage

- Store the module in a dark place, where the temperature is $25 \pm 10^\circ\text{C}$ and the relative humidity below 65%. If possible, store the module in the packaging situation when it was delivered.
- Do not store the module near organic solvents or corrosive gases.
- Keep the module (including accessories) safe from vibration, shock and pressure.
- Use the products within 6 months of receiving it. (For LCD modules with EL backlight)

- Because the EL backlight uses organic materials that are very sensitive to heat and humidity, there may be some loss of quality when stored for long periods of time. Contact SII for further detail.
- Black or white air-bubbles may be produced if the module is stored for a long time in the lower temperature or mechanical shocks are applied onto the module.
- To set an EL lamp in an LCD module, push the EL lamp with its emitting side up, without pushing the rubber connectors too hard. If you damage them, the LCD module may not work properly.
- Do not damage the film surface of the EL lamp ; otherwise the lamp will be damaged by humidity.

Cleaning

- Do not wipe the polarizer with a dry cloth, as it may scratch the surface.
- Wipe the module gently with a soft cloth soaked with a petroleum benzine.
- Do not use ketonic solvents (ketone and acetone) or aromatic solvents (toluene and xylene), as they may damage the polarizer.

1.2 Handling the LED Backlight Unit

- When soldering the connector for LED backlight unit, the soldering iron temperature should not exceed 260°C, and soldering time should be within 3 seconds. (L1681, L1672, L1692, L2032, L4051, L4052)
- For cleaning, wipe with soft cloth and use only the following chemicals.
 - Ethanol
 - Isopropyl alcohol

1.3 Mounting of an EL Lamp and an Inverter

- Your design should make it easy to replace EL lamps since they have a shorter service life than the other components of LCD modules.
- Do not bend the EL leads when soldering them on the circuit board of the LCD modules ; otherwise they may break.

2. RELIABILITY

2.1 Reliability Test

(1) Standard type

Test item	Test conditions	Results
High temp. and humidity operation*	40°C ± 2°C 90%RH 500 hours	No abnormalities in functions** and appearance***
High temp. operation*	60°C ± 2°C 500 hours	
Heat shock*	-20°C ⇄ +60°C : 10 cycles 1 hour at each temp. 5 min. transition	
Low temp. storage*	-20°C ± 2°C 500 hours	
Vibration	Sweep : 10Hz to 55Hz 1 min/cycle Amplitude : 1.5mm 2 hours in X, Y and Z directions	
Drop shock	Hight : 30cm Dropped onto a board	

(2) Wide temperature range type

Test item	Test conditions	Results
High temp. and humidity operation*	60°C ± 2°C 90%RH 500 hours	No abnormalities in functions** and appearance***
High temp. operation*	80°C ± 2°C 500 hours	
Heat shock*	-30°C ⇄ +80°C : 10 cycles 1 hour at each temp. 5 min. transition	
Low temp. storage*	-30°C ± 2°C 500 hours	
Vibration	Sweep : 10Hz to 55Hz 1 min/cycle Amplitude : 1.5mm 2 hours in X, Y and Z directions	
Drop shock	Hight : 30cm Dropped onto a board	

* Measurement conditions : Evaluation and judgment of the module should be done two hours after it is returned to room temperature. There should not be any condensation during the test and the ensuing evaluation.

** Current consumption, contrast and display functions

*** Polarizer deterioration and other appearance defects

2.2 LC Panel Life Time

Item	Conditions	Standard	Unit
Life time	25°C±10°C ≤65%RH	100,000 or more	hrs

Definition of life time

(1) Contrast reduces to 30% of the initial value.

(2) Current consumption becomes three times the initial value.

(3) Orientation deteriorates significantly.

(4) The display malfunctions.

3. DEFINITION OF OPTICAL CHARACTERISTICS TERM

■ Angles \varnothing and θ

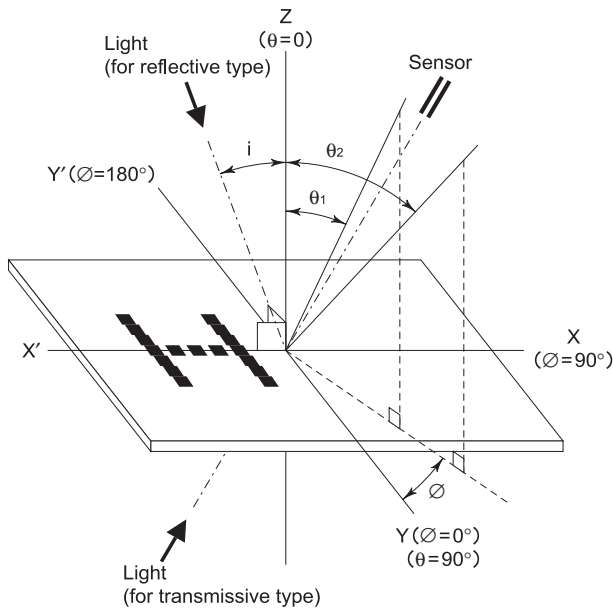

■ Viewing angles θ_1 and θ_2

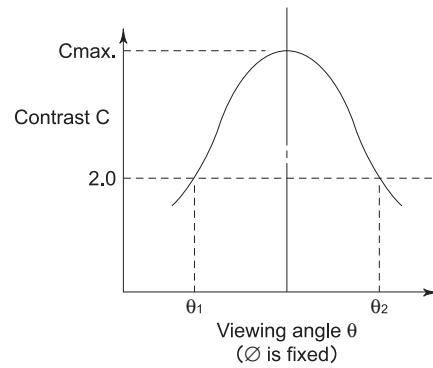

Remark : The optimum viewing angle by visual inspection and angle θ at C_{max} do not always match.

■ Contrast C

$$C = \frac{\text{Brightness (reflection) of unselected dot } (B_2)}{\text{Brightness (reflection) of selected dot } (B_1)}$$

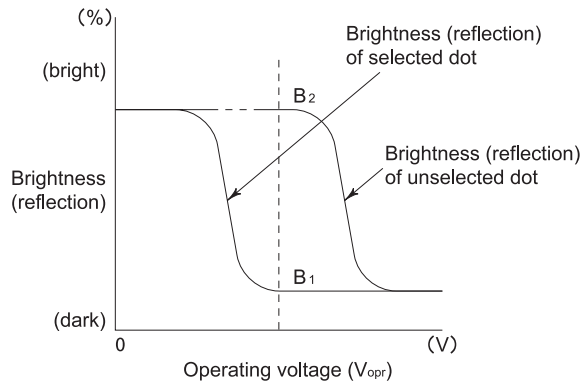

■ Response time

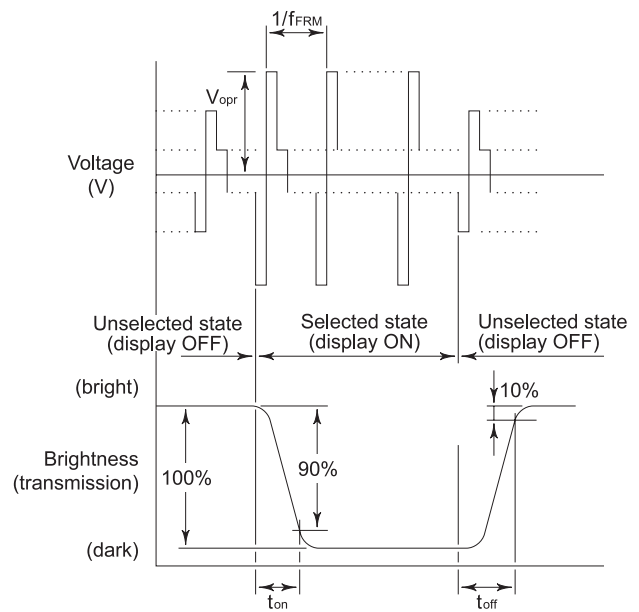

V_{opr} : Operating voltage (V)
 f_{FRM} : Frame frequency (Hz)
 t_{on} : Response time (rise) (ms)
 t_{off} : Response time (fall) (ms)