

User's Guide

NHD-320240WG-ATMI-NZ

LCM

(Liquid Crystal Display Graphic Module)

RoHS Compliant

NHD-	Newhaven Display
320240-	320 x 240 pixels
WG-	W= Factory Line G= Display Type: Graphic
A-	Model / Serial number: A
T-	White LED B/L
M-	STN-(negative)Blue
I-	Transmissive, 6:00 View, Wide Temperature (-20 ~ +70c)
NZ-	Without Negative Voltage; RoHS

For product support, contact

Newhaven Display International
2511 Technology Drive, #101
Elgin, IL 60124

Tel: (847) 844-8795 Fax: (847) 844-8796

November 19, 2008

Contents

1. Module classification information
2. Precautions in Use of LCM
3. General Specification
4. Absolute Maximum Ratings
5. Electrical Characteristics
6. Optical Characteristics
7. Interface Pin Function
8. Contour Drawing & Block Diagram
9. Timing Characteristics
10. Quality Assurance
11. Reliability
12. Backlight Information

2. Precautions in Use of LCD Module

- (1) Avoid applying excessive shocks to the module or making any alterations or modifications to it.
- (2) Don't make extra holes on the printed circuit board, modify its shape or change the components of LCD Module.
- (3) Don't disassemble the LCM.
- (4) Don't operate it above the absolute maximum rating.
- (5) Don't drop, bend or twist LCM.
- (6) Soldering: only to the I/O terminals.
- (7) Storage: please storage in anti-static electricity container and clean environment.

3. General Specification for **NHD-320240WG-ATMI-NZ**

ITEM	STANDARD VALUE	UNIT
Number of dots	320 x 240	dots
Outline dimension	166.8(W) x 109.0(H) x 11.0max(T)	mm
View area	122.0(W) x 92.0(H)	mm
Active area	115.18(W) x 86.38(H)	mm
Dot size	0.34(W) x 0.34(H)	mm
Dot pitch	0.36(W) x 0.36(H)	mm
LCD type	STN- BLUE, Negative, Transmissive	
View direction	6 o'clock	
Backlight	LED, White	

4. Absolute Maximum Ratings

ITEM	SYMBOL	MIN.	TYP.	MAX.	UNIT
Operating Temperature	T_{OP}	-20	—	+70	°C
Storage Temperature	T_{ST}	-30	—	+80	°C
Input Voltage	V_I	0	—	V_{DD}	V
Supply Voltage For Logic	V_{DD}	0	—	6.5	V
Supply Voltage For LCD	$V_{DD}-V_{EE}$	0	—	32	V

5. Electrical Characteristics

ITEM	SYMBOL	CONDITION	MIN.	TYP.	MAX.	UNIT
Logic Voltage	$V_{DD}-V_{SS}$	—	—	5.0	5.5	V
Supply Voltage For LCD	$V_{DD}-V_{EE}$	$T_a=-20^{\circ}\text{C}$	—	—	25.0	V
		$T_a=25^{\circ}\text{C}$	—	24.0	—	V
		$T_a=+70^{\circ}\text{C}$	23.0	—	—	V
Input High Volt.	V_{IH}	—	$0.8V_{DD}$	—	V_{DD}	V
Input Low Volt.	V_{IL}	—	0	—	$0.2V_{DD}$	V
Output High Volt.	V_{OH}	—	$V_{DD}-0.4$	—	—	V
Output Low Volt.	V_{OL}	—	—	—	0.4	V
Supply Current	I_{DD}	—	70.0	75.0	80.0	mA

6. Optical Characteristics

ITEM	SYMBOL	CONDITION	MIN	TYP	MAX	UNIT
View Angle	(V) θ	$CR \geq 2$	10	—	105	deg.
	(H) φ	$CR \geq 2$	-30	—	30	deg.
Contrast Ratio	CR	—	—	3	—	—
Response Time	T rise	—	—	200	300	ms
	T fall	—	—	150	200	ms

6.1 Definitions

■ View Angles

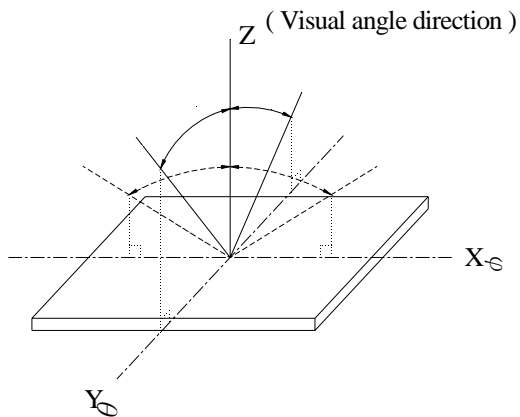

■ Contrast Ratio

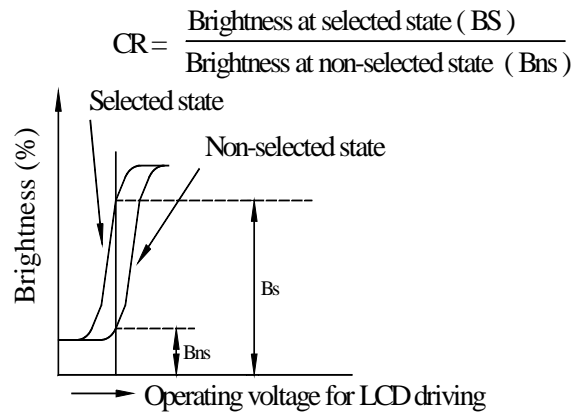

■ Response time

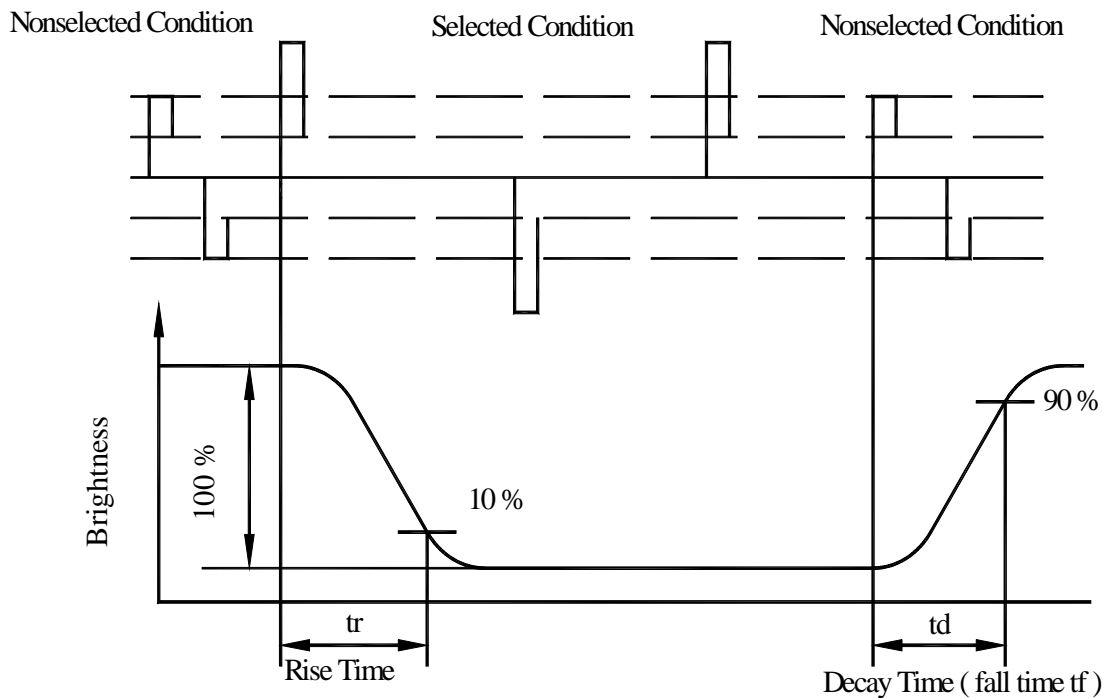

7. Interface Description

Pin No.	Symbol	Level	Description
1	D0	H/L	Display data, bit0
2	D1	H/L	Display data, bit1
3	D2	H/L	Display data, bit2
4	D3	H/L	Display data, bit3
5	$\overline{\text{DISPOFF}}$	H/L	H: Display ON, L: Display OFF
6	FLM	H/L	Scan start-up signal
7	M (N.C.)	H/L	Frame reverse signal (alternate signal)
8	CL1 (LP)	H to L	Data latch pulse
9	CL2 (CP)	H to L	Data shift pulse
10	V_{DD}	5.0V	Power supply for Logic
11	V_{SS}	0V	Ground
12	V_{EE}	-25v	Negative voltage output (Built-in)
13	V_O	(Variable)	Driving voltage for LCD
14	FGND		Frame Ground

8. Contour Drawing & Block diagram

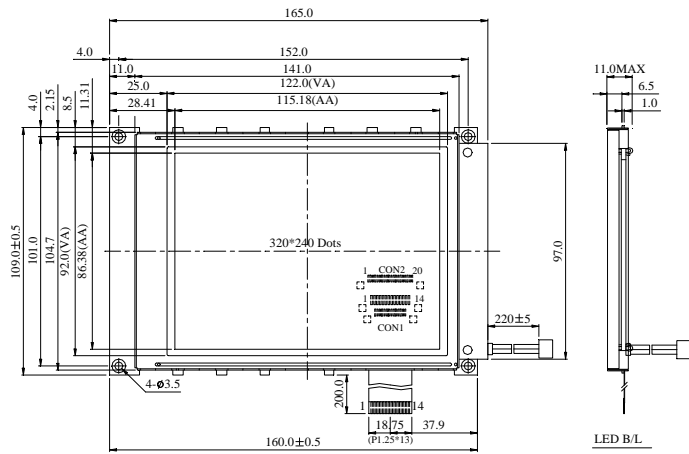

PINNO.	SYMBOL
1	DB0
2	DB1
3	DB2
4	DB3
5	DISPOFF
6	FLM
7	M
8	LP
9	CP
10	Vdd
11	Vss
12	Vee
13	Vo
14	FGND

The non-specified tolerance of dimension is ±0.3mm.

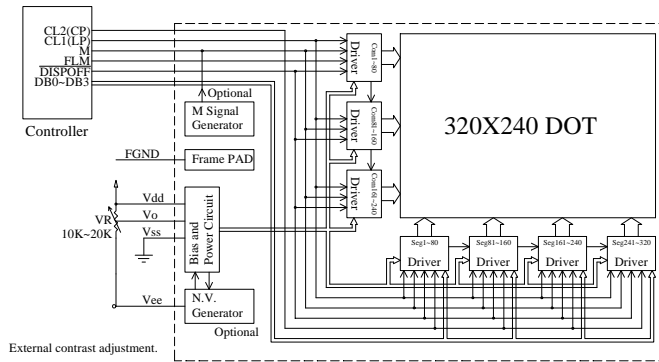
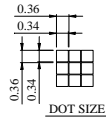

LED B/L drive directly from connector.

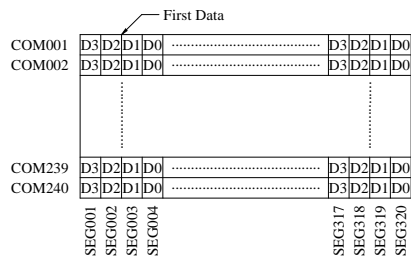
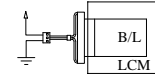

9. Timing Characteristics

9.1. Common & Segment interface timing:

ITEM	symbol	Test Condition	Min.	Typ.	Max.	Units
Clock Cycle	tC	Fig.1	100	—	—	ns
CP Pulse Width	tWC	Fig.1	50	—	—	ns
LP Pulse Width	tWL	Fig.1	50	—	—	ns
Data Set Up Time	tDSU	Fig.1	30	—	—	ns
Data Hold Time	tDHD	Fig.1	30	—	—	ns
CP Rise/Fall Time	tr,tf	Fig.1	—	—	50	ns
CP to LOAD	tCL	Fig.1	80	—	—	ns
LOAD to CP	tLC	Fig.1	110	—	—	ns
LP Pulse Width	tLW	Fig.1	50	—	—	ns
CL1 Pulse Width	tCW	Fig.2	63	—	—	ns
Data Set Up Time	tDSU2	Fig.2	100	—	—	ns
Data Hold Time	tDHD2	Fig.2	100	—	—	ns
CL1 Rise/Fall Time	tr2,tf2	Fig.2	—	—	50	ns

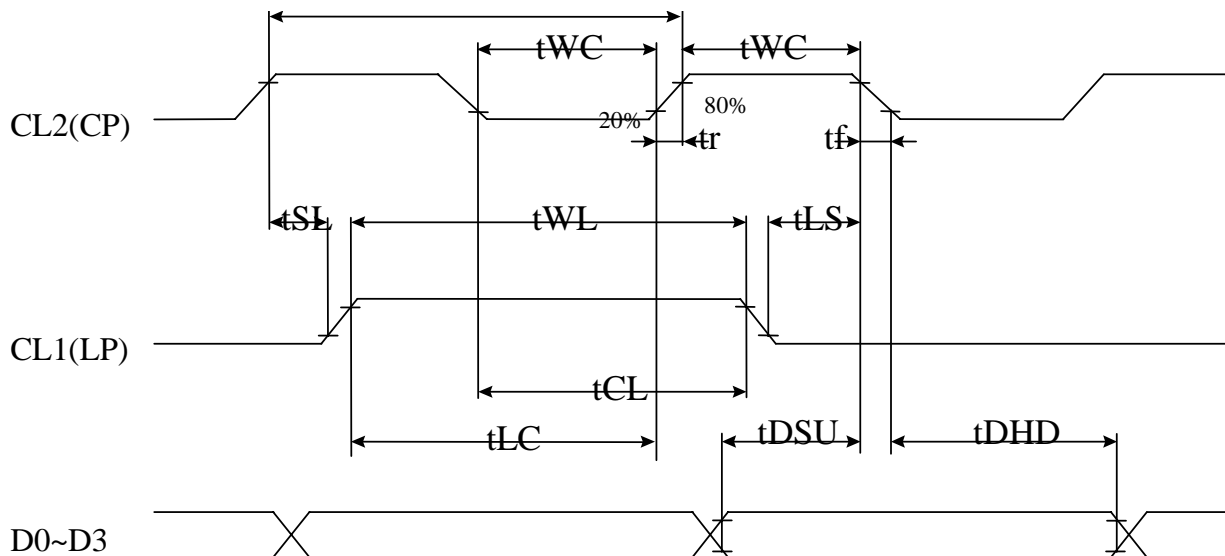

Fig 1. SEGMENT TIMING

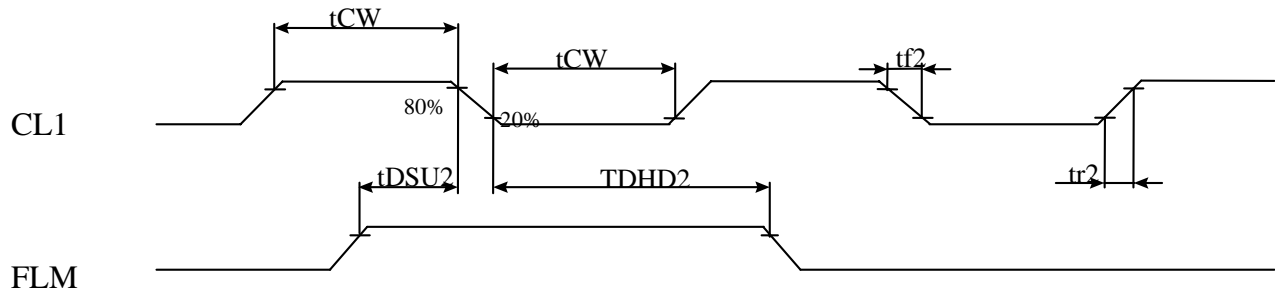
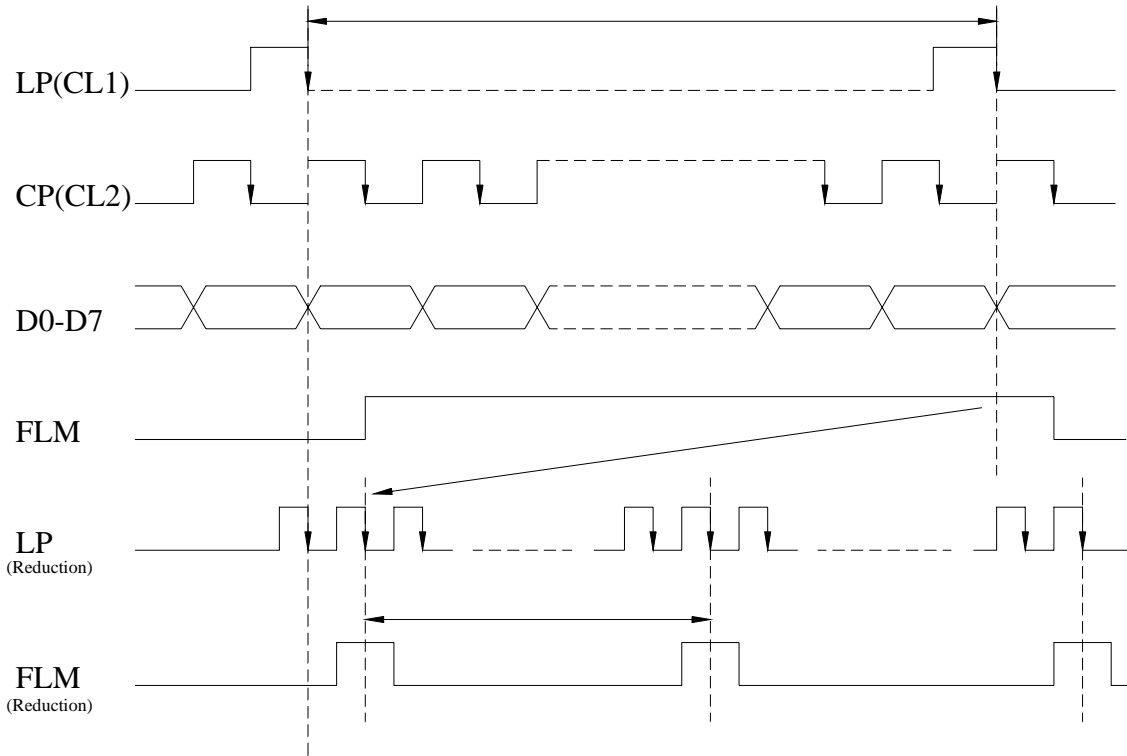
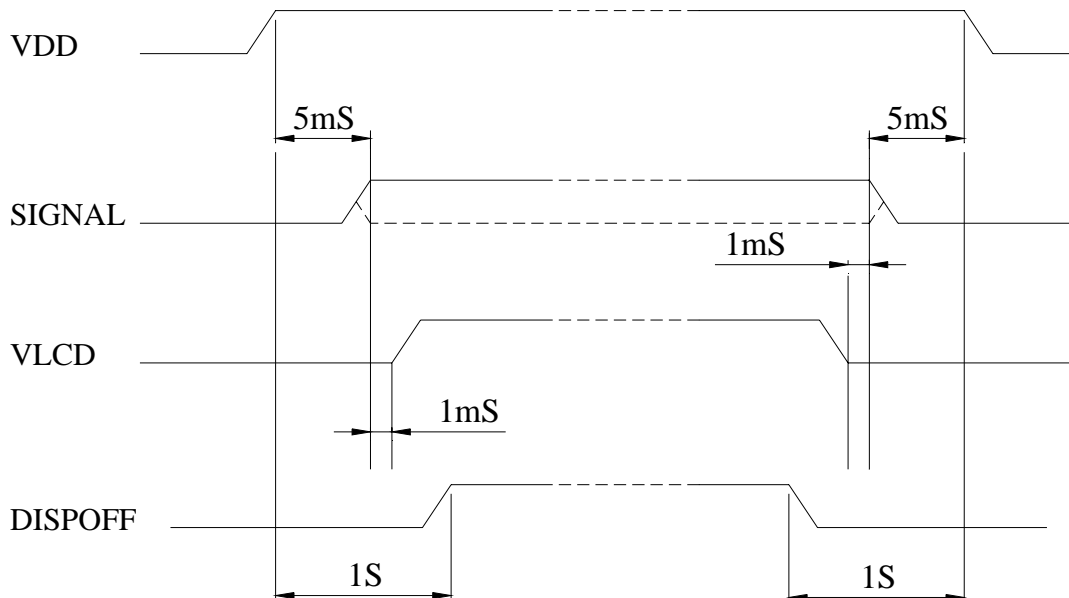

Fig 2 COMMON TIMING

TIMING CHART OF INPUT SIGNAL



POWER ON/OFF TIMING



10. Quality Assurance

◆ Screen Cosmetic Criteria

No.	Defect	Judgement Criteria	Partition																				
1	Spots	<p>A) Clear</p> <table border="1"> <thead> <tr> <th>Size: d mm</th> <th>Acceptable Qty in active area</th> </tr> </thead> <tbody> <tr> <td>$d \leq 0.1$</td> <td>Disregard</td> </tr> <tr> <td>$0.1 < d \leq 0.2$</td> <td>6</td> </tr> <tr> <td>$0.2 < d \leq 0.3$</td> <td>2</td> </tr> <tr> <td>$0.3 < d$</td> <td>0</td> </tr> </tbody> </table> <p>Note: Including pin holes and defective dots which must be within one pixel size.</p> <p>B) Unclear</p> <table border="1"> <thead> <tr> <th>Size: d mm</th> <th>Acceptable Qty in active area</th> </tr> </thead> <tbody> <tr> <td>$d \leq 0.2$</td> <td>Disregard</td> </tr> <tr> <td>$0.2 < d \leq 0.5$</td> <td>6</td> </tr> <tr> <td>$0.5 < d \leq 0.7$</td> <td>2</td> </tr> <tr> <td>$0.7 < d$</td> <td>0</td> </tr> </tbody> </table>	Size: d mm	Acceptable Qty in active area	$d \leq 0.1$	Disregard	$0.1 < d \leq 0.2$	6	$0.2 < d \leq 0.3$	2	$0.3 < d$	0	Size: d mm	Acceptable Qty in active area	$d \leq 0.2$	Disregard	$0.2 < d \leq 0.5$	6	$0.5 < d \leq 0.7$	2	$0.7 < d$	0	Minor
Size: d mm	Acceptable Qty in active area																						
$d \leq 0.1$	Disregard																						
$0.1 < d \leq 0.2$	6																						
$0.2 < d \leq 0.3$	2																						
$0.3 < d$	0																						
Size: d mm	Acceptable Qty in active area																						
$d \leq 0.2$	Disregard																						
$0.2 < d \leq 0.5$	6																						
$0.5 < d \leq 0.7$	2																						
$0.7 < d$	0																						
2	Bubbles in Polarize	<table border="1"> <thead> <tr> <th>Size: d mm</th> <th>Acceptable Qty in active area</th> </tr> </thead> <tbody> <tr> <td>$d \leq 0.3$</td> <td>Disregard</td> </tr> <tr> <td>$0.3 < d \leq 1.0$</td> <td>3</td> </tr> <tr> <td>$1.0 < d \leq 1.5$</td> <td>1</td> </tr> <tr> <td>$1.5 < d$</td> <td>0</td> </tr> </tbody> </table>	Size: d mm	Acceptable Qty in active area	$d \leq 0.3$	Disregard	$0.3 < d \leq 1.0$	3	$1.0 < d \leq 1.5$	1	$1.5 < d$	0	Minor										
Size: d mm	Acceptable Qty in active area																						
$d \leq 0.3$	Disregard																						
$0.3 < d \leq 1.0$	3																						
$1.0 < d \leq 1.5$	1																						
$1.5 < d$	0																						
3	Scratch	In accordance with spots cosmetic criteria. When the light reflects on the panel surface, the scratches are not to be remarkable.	Minor																				
4	Allowable Density	Above defects should be separated more than 30mm each other.	Minor																				
5	Coloration	Not to be noticeable coloration in the viewing area of the LCD panels. Back-light type should be judged with back-light on state only.	Minor																				

11. RELIABILITY

Content of Reliability Test

Environmental Test				
No.	Test Item	Content of Test	Test Condition	Applicable Standard
1	High Temperature storage	Endurance test applying the high storage temperature for a long time.	80°C 200hrs	—
2	Low Temperature storage	Endurance test applying the high storage temperature for a long time.	-30°C 200hrs	—
3	High Temperature Operation	Endurance test applying the electric stress (Voltage & Current) and the thermal stress to the element for a long time.	70°C 200hrs	—
4	Low Temperature Operation	Endurance test applying the electric stress under low temperature for a long time.	-20°C 200hrs	—
5	High Temperature/ Humidity Storage	Endurance test applying the high temperature and high humidity storage for a long time.	80°C,90%RH 96hrs	—
6	High Temperature/ Humidity Operation	Endurance test applying the electric stress (Voltage & Current) and temperature / humidity stress to the element for a long time.	70°C,90%RH 96hrs	—
7	Temperature Cycle	Endurance test applying the low and high temperature cycle. $ \begin{array}{c} -30^{\circ}\text{C} \quad 25^{\circ}\text{C} \quad 80^{\circ}\text{C} \\ \longleftarrow \hspace{1.5cm} \longrightarrow \\ 30\text{min} \quad 5\text{min} \quad 30\text{min} \\ \hline 1 \text{ cycle} \end{array} $	-30°C/80°C 10 cycles	—
Mechanical Test				
8	Vibration test	Endurance test applying the vibration during transportation and using.	10~22Hz→1.5mmp-p 22~500Hz→1.5G Total 0.5hrs	—
9	Shock test	Constructional and mechanical endurance test applying the shock during transportation.	50G Half sign wave 11 msdc 3 times of each direction	—
10	Atmospheric pressure test	Endurance test applying the atmospheric pressure during transportation by air.	115mbar 40hrs	—
Others				
11	Static electricity test	Endurance test applying the electric stress to the terminal.	VS=800V,RS=1.5kΩ CS=100pF 1 time	—

***Supply voltage for logic system=5V. Supply voltage for LCD system =Operating voltage at 25°C

12. Backlight Information

(Ta=25°C)

PARAMETER	SYMBOL	MIN	TYP	MAX	UNIT	TEST CONDITION
Supply Current	I _{LED}	-	150	180	mA	V=3.7V
Supply Voltage	V	-	3.5	3.6	V	-
Reverse Voltage	V _R	-	-	10	V	-
Luminous Intensity	I _V	-	30	-	CD/M ²	I _{LED} =160mA
Wave Length	λ _p	-	-	-	nm	I _{LED} =160mA
Life Time	-	-	50K	-	Hr.	V ≤ 3.6mA
Color	White					