

# NHD-320240WG-CoTFH-VZ#-010-80

## Graphic Liquid Crystal Display Module

NHD-	Newhaven Display
320240-	320 x 240 pixels
WG-	Display Type: Graphic
Co-	Model
T-	White LED Backlight
F-	FSTN (+)
H-	Transflective, 6:00 view, Wide Temperature (-20°C ~+70°C)
VZ#-	Built-in Negative Voltage
010-80-	Backlight A (+5V)= Pin19, K= Pin20, Intel 8080 interface mode

**RoHS Compliant**

**Newhaven Display International, Inc.**

2511 Technology Drive, Suite 101

Elgin IL, 60124

Ph: 847-844-8795

Fax: 847-844-8796

[www.newhavendisplay.com](http://www.newhavendisplay.com)

[nhtech@newhavendisplay.com](mailto:nhtech@newhavendisplay.com)

[nhsales@newhavendisplay.com](mailto:nhsales@newhavendisplay.com)

## Document Revision History

Revision	Date	Description	Changed by
0	6/7/2007	Initial Release	-
1	3/17/2010	User guide reformat	MC

## Functions and Features

- 320 x 240 pixels
- Built-in RA8835 Controller
- +5.0V power supply
- RoHS Compliant

# Mechanical Drawing

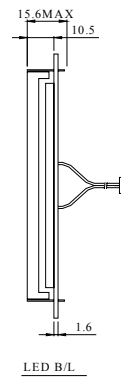
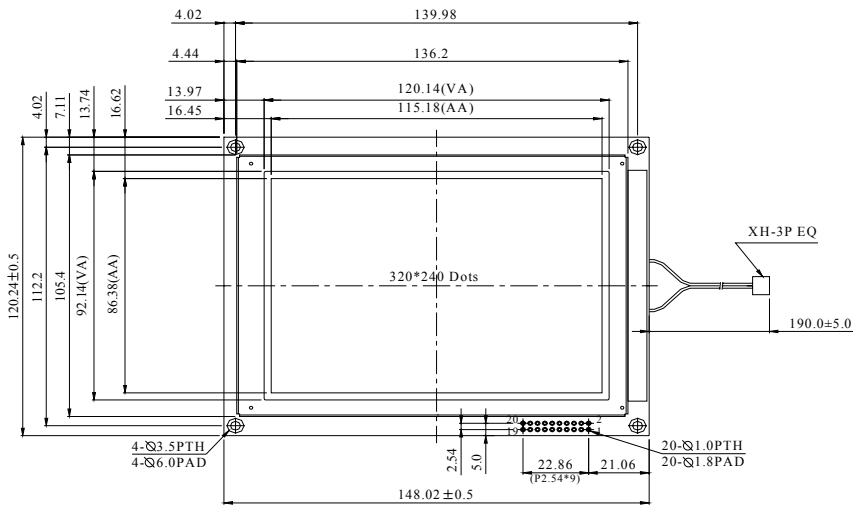

PIN NO.	SYMBOL
1	V <sub>ss</sub>
2	V <sub>dd</sub>
3	V <sub>o</sub>
4	E
5	R/W
6	A0
7	DB0
8	DB1
9	DB2
10	DB3
11	DB4
12	DB5
13	DB6
14	DB7
15	/CS
16	/RST
17	V <sub>ee</sub>
18	FG
19	LED+
20	LED-

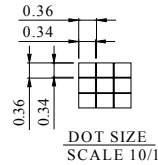
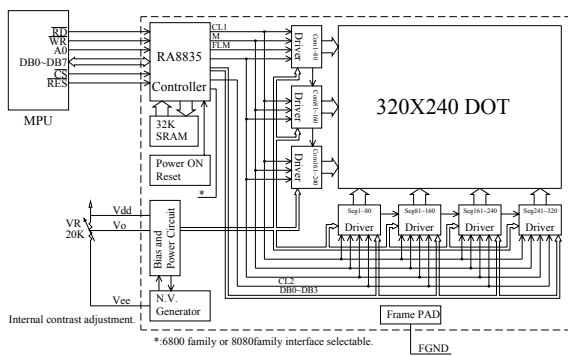

Newhaven Display

NHD-320240WG-CoTFH-VZ#-010-80

## Pin Description and Wiring Diagram

Pin No.	Symbol	External Connection	Function Description
1	VSS	Power Supply	Ground
2	VDD	Power Supply	Power supply for logic (+5.0V)
3	V0	Adj Power Supply	Power supply for contrast (approx. -18.8V)
4	E	MPU	Operation enable signal. Falling edge triggered.
5	R/W	MPU	Read/Write select signal, R/W=1: Read R/W=0: Write
6	A0	MPU	Register select signal. A0=0: Command, A0=1: Data
7-14	DB0-DB7	MPU	Bi-directional three-state data bus lines.
15	/CS	MPU	Active LOW chip select
16	/RST	MPU	Active LOW reset signal
17	VEE	Power Supply	Negative voltage output (-25V)
18	FG	Power Supply	Frame Ground
19	LED+	Power Supply	Power Supply for LED Backlight (+5.0V)
20	LED-	Power Supply	Ground for Backlight

**Recommended LCD connector:** 2.54mm pitch pins

**Backlight connector:** JST p/n: XHP-3      **Mates with:** JST p/n: S3B-XH-SM3-TB

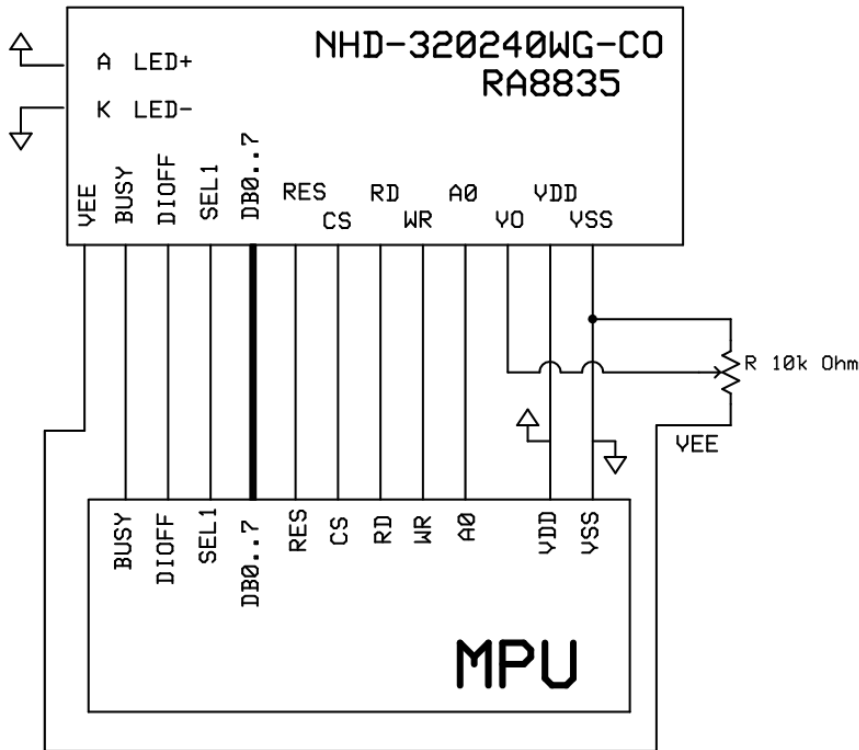

## Electrical Characteristics

Item	Symbol	Condition	Min.	Typ.	Max.	Unit
Operating Temperature Range	Top	Absolute Max	-20	-	+70	°C
Storage Temperature Range	Tst	Absolute Max	-30	-	+80	°C
Supply Voltage	VDD		4.5	5.0	5.5	V
Supply Current	IDD	Ta=25°C, VDD=5.0V	95.0	100.0	110.0	mA
Supply for LCD (contrast)	VDD-VLCD	Ta=25°C	23.0	23.8	25.0	V
"H" Level input	VIH		0.5VDD	-	VDD	V
"L" Level input	VIL	-	0	-	0.2VDD	V
"H" Level output	VOH	-	2.4	-	-	V
"L" Level output	VOL	-	-	-	0.4	V
Backlight Supply Voltage	VLED		4.8	5.0	5.1	V
Backlight Supply Current	ILED	VLED=5.0V	130	160	200	mA
Backlight Lifetime		ILED=160mA	-	50,000	-	Hrs

## Optical Characteristics

Item	Symbol	Condition	Min.	Typ.	Max.	Unit
Viewing Angle - Vertical	AV	Cr ≥ 3	-30	-	60	°
Viewing Angle - Horizontal	AH	Cr ≥ 3	-45	-	45	°
Contrast Ratio	Cr		-	5	-	-
Response Time (rise)	Tr	-	-	200	300	ms
Response Time (fall)	Tf	-	-	150	200	ms

## Controller Information

Built-in RA8835. Download specification at [http://www.newhavendisplay.com/app\\_notes/RA8835.pdf](http://www.newhavendisplay.com/app_notes/RA8835.pdf)

# Table of Commands

Table-1: Command Set

Class	Command	Code											Hex	Command Description	Command Read Parameters	
		RD	WR	A0	D7	D6	D5	D4	D3	D2	D1	D0			No. of Bytes	Section
System Control	<b>SYSTEM SET</b>	1	0	1	0	1	0	0	0	0	0	0	40	Initialize device and display	8	9-2-1
	<b>SLEEP IN</b>	1	0	1	0	1	0	1	0	0	1	1	53	Enter standby mode	0	9-2-2
Display Control	<b>DISPLAY ON/OFF</b>	1	0	1	0	1	0	1	1	0	0	D	58, 59	Enable and disable display and display flashing	1	9-3-1
	<b>SCROLL</b>	1	0	1	0	1	0	0	0	1	0	0	44	Set display start address and display regions	10	9-3-2
	<b>CSRFORM</b>	1	0	1	0	1	0	1	1	1	0	1	5D	Set cursor type	2	9-3-3
	<b>CGRAM ADR</b>	1	0	1	0	1	0	1	1	1	0	0	5C	Set start address of character generator RAM	2	9-3-6
	<b>CSRDIR</b>	1	0	1	0	1	0	0	1	1	CD 1	CD 0	4C to 4F	Set direction of cursor movement	0	9-3-4
	<b>HDOT SCR</b>	1	0	1	0	1	0	1	1	0	1	0	5A	Set horizontal scroll position	1	9-3-7
	<b>OVLAY</b>	1	0	1	0	1	0	1	1	0	1	1	5B	Set display overlay format	1	9-3-5
Drawing Control	<b>CSRW</b>	1	0	1	0	1	0	0	0	1	1	0	46	Set cursor address	2	9-r1
	<b>CSRR</b>	1	0	1	0	1	0	0	0	1	1	1	47	Read cursor address	2	9-4-2
Memory Control	<b>MWRITE</b>	1	0	1	0	1	0	0	0	0	1	0	42	Write to display memory	—	9-5-1
	<b>MREAD</b>	1	0	1	0	1	0	0	0	0	1	1	43	Read from display memory	—	9-5-2

# Timing Characteristics

## 10-3-1 8080 Family Interface Timing

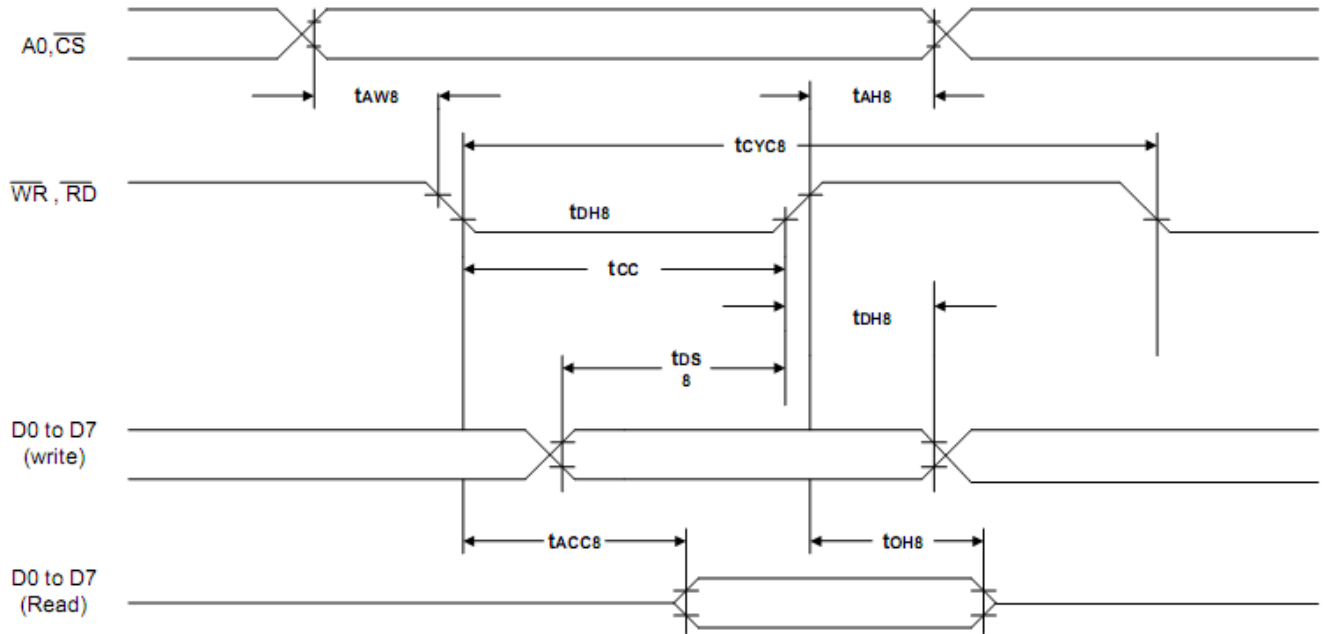

$T_a = -20$  to  $75^\circ\text{C}$

Signal	Symbol	Parameter	$V_{DD} = 4.5$ to $5.5\text{V}$		$V_{DD} = 2.7$ to $4.5\text{V}$		Unit	Condition
			Min.	Max.	Min.	Max.		
A0, $\overline{\text{CS}}$	$t_{AH8}$	Address hold time	10	—	10	—	ns	CL = 100pF
	$t_{AW8}$	Address setup time	0	—	0	—	ns	
$\overline{\text{WR}}$ , $\overline{\text{RD}}$	$t_{CYC8}$	System cycle time	note.	—	note.	—	ns	
	$t_{CC}$	Strobe pulse width	120	—	150	—	ns	
D0 to D7	$t_{DS8}$	Data setup time	120	—	120	—	ns	
	$t_{DH8}$	Data hold time	5	—	5	—	ns	
	$t_{ACC8}$	$\overline{\text{RD}}$ access time	—	50	—	80	ns	
	$t_{OH8}$	Output disable time	10	50	10	55	ns	

**Note:** For memory control and system control commands:

$$t_{CYC8} = 2t_C + t_{CC} + t_{CEA} + 75 > t_{ACV} + 245$$

For all other commands:

$$t_{CYC8} = 4t_C + t_{CC} + 30$$

## 10-3-2 6800 Family Interface Timing

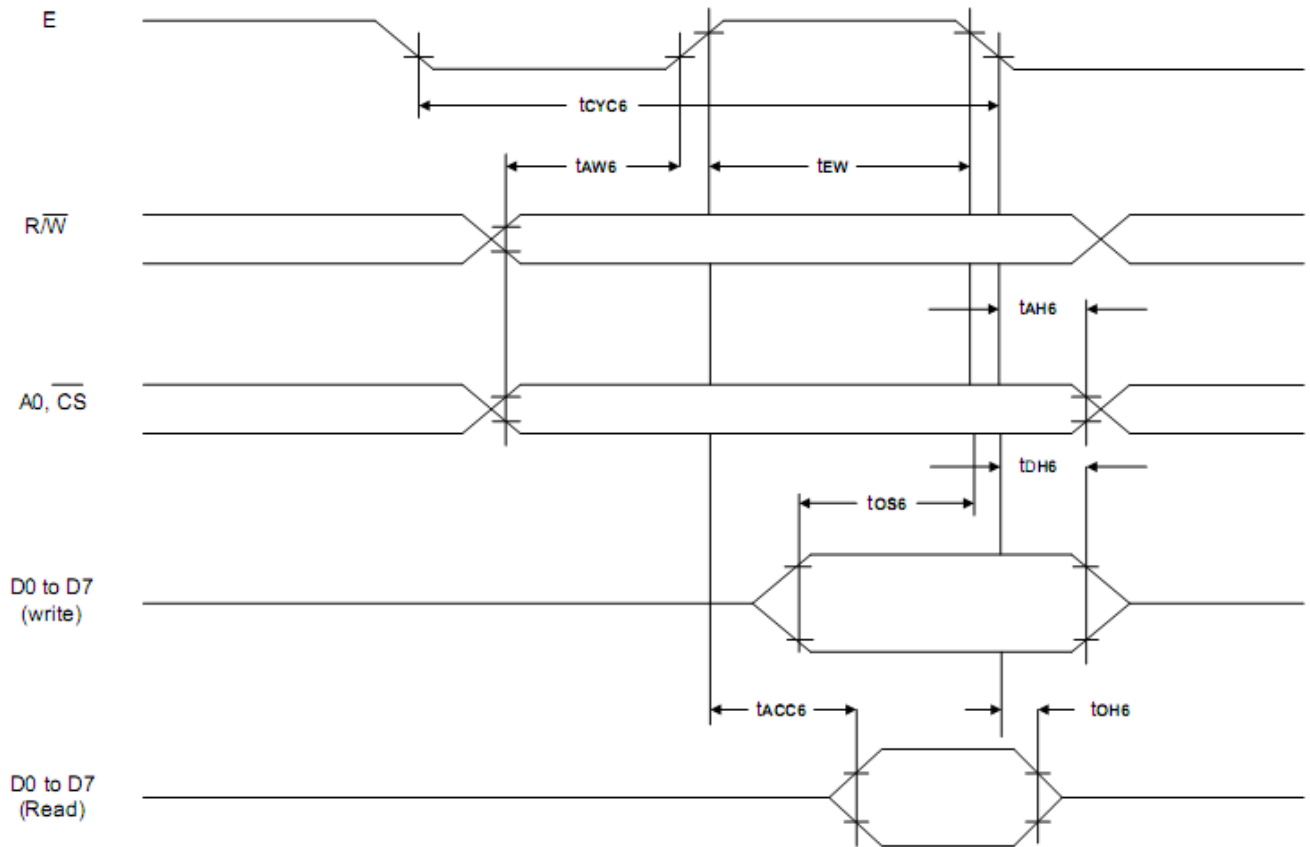

Ta = -20 to 75°C

Signal	Symbol	Parameter	V <sub>DD</sub> = 4.5 to 5.5V		V <sub>DD</sub> = 2.7 to 4.5V		Unit	Condition
			Min.	Max.	Min.	Max.		
A0, $\overline{\text{CS}}$ , R/(W)	t <sub>CYC6</sub>	System cycle time	note.	—	note.	—	ns	CL = 100 pF
	t <sub>AW6</sub>	Address setup time	0	—	10	—	ns	
	t <sub>AH6</sub>	Address hold time	0	—	0	—	ns	
D0 to D7	t <sub>DS6</sub>	Data setup time	100	—	120	—	ns	
	t <sub>DH6</sub>	Data hold time	0	—	0	—	ns	
	t <sub>OH6</sub>	Output disable time	10	50	10	75	ns	
	t <sub>ACC6</sub>	Access time	—	85	—	130	ns	
E	t <sub>EW</sub>	Enable pulse width	120	—	150	—	ns	

**Note:** For memory control and system control commands:

$$t_{\text{CYC6}} = 2t_{\text{C}} + t_{\text{EW}} + t_{\text{CEA}} + 75 > t_{\text{ACV}} + 245$$

For all other commands:

$$t_{\text{CYC6}} = 4t_{\text{C}} + t_{\text{EW}} + 30$$



## Initialization Code

```
//-----  
#define A0 P3_0  
#define RW P3_7  
#define E P3_4  
#define CS P3_1  
#define RESET P3_6  
  
//-----  
void data_out(unsigned char i) //Data Output 16-bit Bus Interface  
{  
    A0 = 0;  
    P1 = i;  
    CS = 0;  
    RW = 0;  
    E = 1;  
    delay(1);  
    E = 0;  
    RW = 1;  
    CS = 1;  
}  
void comm_out(unsigned char j) //Command Output 8-bit Bus Interface  
{  
    A0 = 1;  
    P1 = j;  
    CS = 0;  
    RW = 0;  
    E = 1;  
    delay(1);  
    E = 0;  
    RW = 1;  
    CS = 1;  
}  
  
//-----  
//          Initialization For RA8835  
//-----  
void resetLCD()  
{  
    RESET = 0;  
    delay(5);  
    RESET = 1;  
    delay(10);  
}  
void init_LCD()
```

## Quality Information

Test Item	Content of Test	Test Condition	Note
High Temperature storage	Endurance test applying the high storage temperature for a long time.	+80°C , 200hrs	2
Low Temperature storage	Endurance test applying the low storage temperature for a long time.	-30°C , 200hrs	1,2
High Temperature Operation	Endurance test applying the electric stress (voltage & current) and the high thermal stress for a long time.	+70°C 200hrs	2
Low Temperature Operation	Endurance test applying the electric stress (voltage & current) and the low thermal stress for a long time.	-20°C , 200hrs	1,2
High Temperature / Humidity Operation	Endurance test applying the electric stress (voltage & current) and the high thermal with high humidity stress for a long time.	+60°C , 90% RH , 96hrs	1,2
Thermal Shock resistance	Endurance test applying the electric stress (voltage & current) during a cycle of low and high thermal stress.	-20°C,30min -> 25°C,5min -> 70°C,30min = 1 cycle 10 cycles	
Vibration test	Endurance test applying vibration to simulate transportation and use.	10-55Hz , 15mm amplitude. 60 sec in each of 3 directions X,Y,Z For 15 minutes	3
Static electricity test	Endurance test applying electric static discharge.	VS=800V, RS=1.5kΩ, CS=100pF One time	

**Note 1:** No condensation to be observed.

**Note 2:** Conducted after 4 hours of storage at 25°C, 0%RH.

**Note 3:** Test performed on product itself, not inside a container.

## Precautions for using LCDs/LCMs

See Precautions at [www.newhavendisplay.com/specs/precautions.pdf](http://www.newhavendisplay.com/specs/precautions.pdf)

## Warranty Information and Terms & Conditions

[http://www.newhavendisplay.com/index.php?main\\_page=terms](http://www.newhavendisplay.com/index.php?main_page=terms)