

NHD-C0220BiZ-FSW-FBW-3V3M

COG (Chip-On-Glass) Character Liquid Crystal Display Module

NHD-	Newhaven Display
C0220-	COG 2 lines x 20 characters
BiZ-	Model, with I2C interface
F-	Transflective
SW-	Side White LED backlight
F-	FSTN (+)
B-	6:00 view
W-	Wide Temp (-20°C ~ +70°C)
3V3-	3.3V power supply
M-	with Mounting holes
	RoHS Compliant

Newhaven Display International, Inc.

2511 Technology Drive, Suite 101

Elgin IL, 60124

Ph: 847-844-8795

Fax: 847-844-8796

www.newhavendisplay.com

nhtech@newhavendisplay.com

nhsales@newhavendisplay.com

Document Revision History

Revision	Date	Description	Changed by
0	7/8/2009	Initial Release	
1	10/9/2009	Updated Electrical Characteristic	MC
2	11/20/2009	Updated backlight supply current	MC

Functions and Features

- 2 lines x 20 characters
- Built-in ST7036i controller with I2C interface
- 3.3V power supply
- 1/16 duty, 1/5 bias
- Built-in DC supply for VLCD (requires 2 external capacitors)

Mechanical Drawing

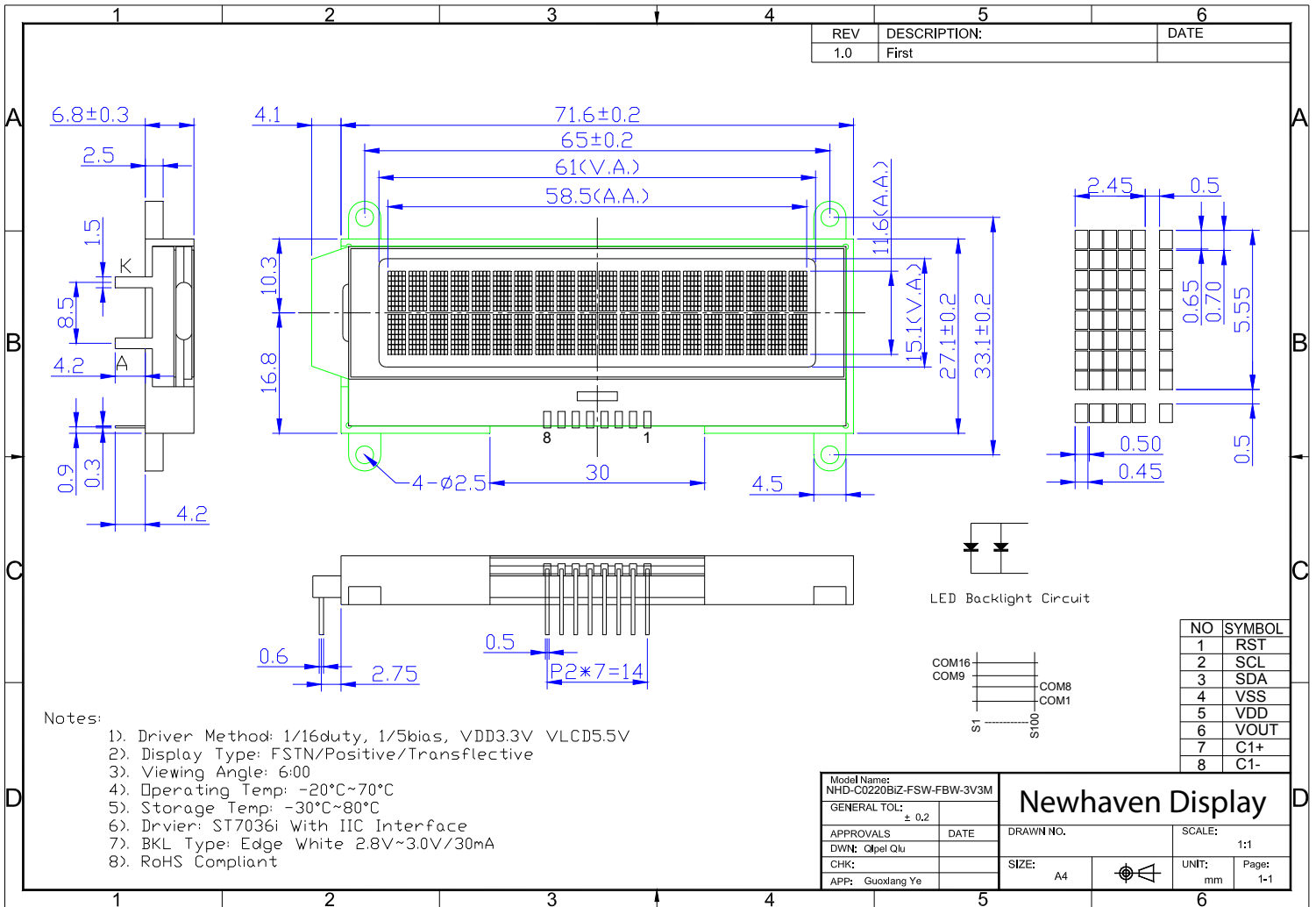

REV	DESCRIPTION:	DATE
1.0	First	

Notes:

- 1). Driver Method: 1/16duty, 1/5bias, VDD3.3V VLCD5.5V
- 2). Display Type: FSTN/Positive/Transflective
- 3). Viewing Angle: 6:00
- 4). Operating Temp: $-20^{\circ}\text{C} \sim 70^{\circ}\text{C}$
- 5). Storage Temp: $-30^{\circ}\text{C} \sim 80^{\circ}\text{C}$
- 6). Driver: ST7036i with IIC Interface
- 7). BKL Type: Edge White 2.8V~3.0V/30mA
- 8). RoHS Compliant

LED Backlight Circuit

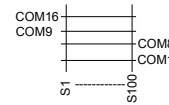

NO	SYMBOL
1	RST
2	SCL
3	SDA
4	VSS
5	VDD
6	VOUT
7	C1+
8	C1-

Model Name: NHD-C0220BIZ-FSW-FBW-3V3M	
GENERAL TOL:	± 0.2
APPROVALS	DATE
DWN: Qipel Qiu	
CHK:	
APP: Guoxiang Ye	

Newhaven Display

DRAWN NO.	SCALE:
	1:1
SIZE: A4	UNIT: mm
	Page: 1-1

Pin Description and Wiring Diagram

Pin No.	Symbol	External Connection	Function Description
1	RST	MPU	Active LOW Reset
2	SCL	MPU	Serial Clock (requires pull-up resistor)
3	SDA	MPU	Serial Data (requires pull-up resistor)
4	VSS	Power Supply	GND
5	VDD	Power Supply	+3.3V
6	VOUT	CAP	Voltage booster circuit – connect to 1uF cap to VSS or VDD
7	C1+	CAP	Connect to 1uF cap to PIN8
8	C1-	CAP	Connect to 1uF cap to PIN7

Recommended LCD connector: 2.0mm pitch pins, solder directly into PCB

Backlight connector: 8.5mm pitch pins, solder directly into PCB **Mates with:** ---

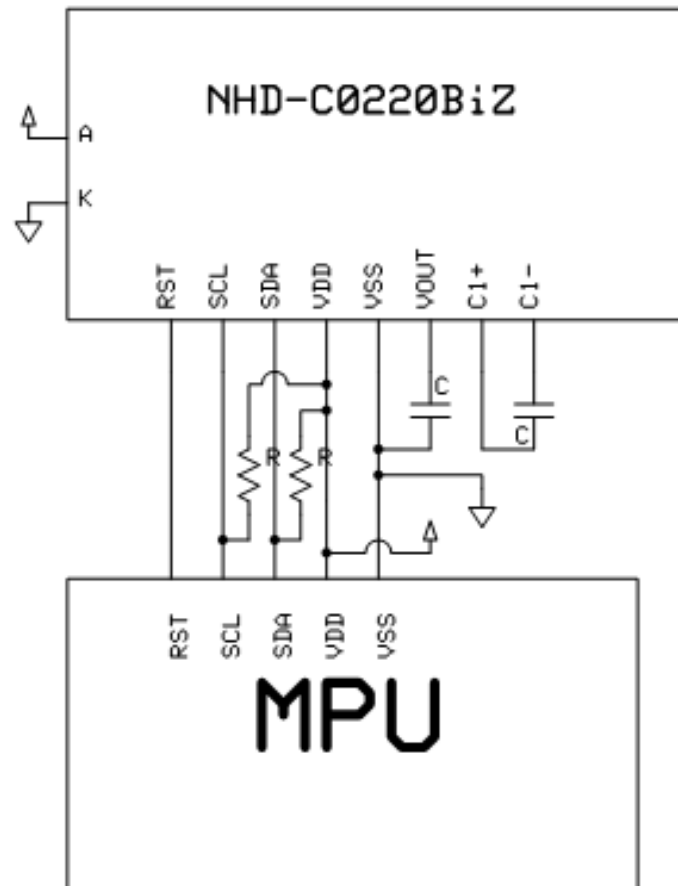

Capacitance 0.47uF~2.2uF

Recommended value = 1uF

Electrical Characteristics

Item	Symbol	Condition	Min.	Typ.	Max.	Unit
Operating Temperature Range	Top	Absolute Max	-20	-	+70	°C
Storage Temperature Range	Tst	Absolute Max	-30	-	+80	°C
Supply Voltage	VDD		2.7	3.3	3.5	V
Supply Current	IDD	VDD=3.3V		1		mA
Supply for LCD (contrast)	VDD-V0	VLCD=VDD-V0	2.7		7.0	V
"H" Level input	Vih		0.7VDD	-	VDD	V
"L" Level input	Vil		0	-	0.8	V
"H" Level output	Voh		0.7VDD	-	VDD	V
"L" Level output	Vol		-	-	0.8	V
Backlight Supply Voltage – White	VLED	-	2.8	3.0	3.0	V
Backlight Supply Current – White	Iled	-	-	30	45	mA

Optical Characteristics

Item	Symbol	Condition	Min.	Typ.	Max.	Unit
Viewing Angle - Vertical	AV	Cr ≥ 2	-60		+35	°
Viewing Angle - Horizontal	AH	Cr ≥ 2	-40		+40	°
Contrast Ratio	Cr		-	6	-	
Response Time (rise)	Tr	-	-	150	200	ms
Response Time (fall)	Tr	-	-	150	200	ms

Controller Information

Built-in ST7036i. Download specification at http://www.newhavendisplay.com/app_notes/ST7036.pdf

Slave Address = 0x78

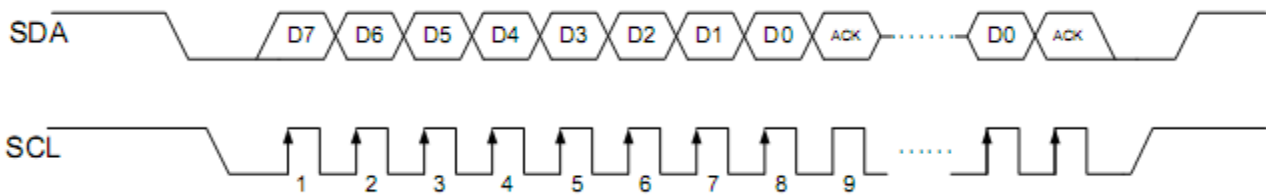
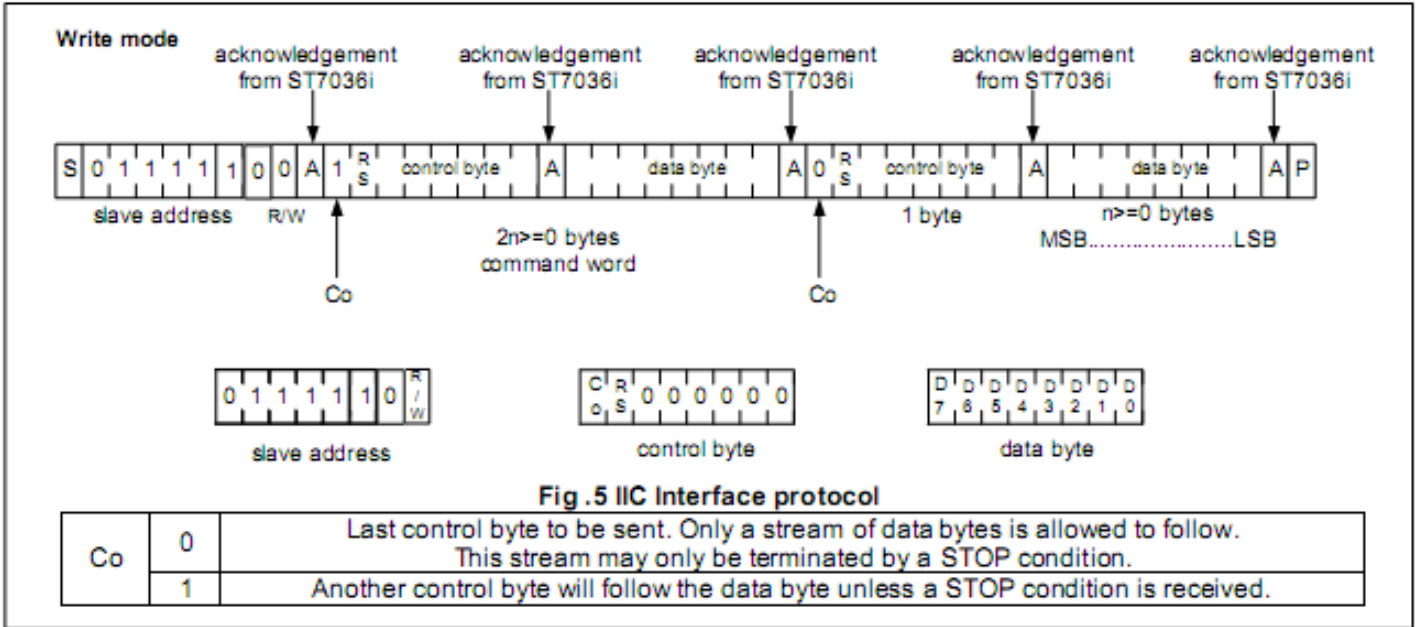

Table of Commands

Instruction	Instruction Code										Description
	RS	R/W	DB7	DB6	DB5	DB4	DB3	DB2	DB1	DB0	
Clear Display	0	0	0	0	0	0	0	0	0	1	Write "20H" to DDRAM. and set DDRAM address to "00H" from AC
Return Home	0	0	0	0	0	0	0	0	1	x	Set DDRAM address to "00H" from AC and return cursor to its original position if shifted. The contents of DDRAM are not changed.
Entry Mode Set	0	0	0	0	0	0	0	1	I/D	S	Sets cursor move direction and specifies display shift. These operations are performed during data write and read.
Display ON/OFF	0	0	0	0	0	0	1	D	C	B	D=1:entire display on C=1:cursor on B=1:cursor position on
Function Set	0	0	0	0	1	DL	N	DH	IS2	IS1	DL: interface data is 8/4 bits N: number of line is 2/1 DH: double height font IS[2:1]: instruction table select
Set DDRAM Address	0	0	1	AC6	AC5	AC4	AC3	AC2	AC1	AC0	Set DDRAM address in address counter
Read Busy Flag and Address	0	1	BF	AC6	AC5	AC4	AC3	AC2	AC1	AC0	Whether during internal operation or not can be known by reading BF. The contents of address counter can also be read.
Write Data to RAM	1	0	D7	D6	D5	D4	D3	D2	D1	D0	Write data into internal RAM (DDRAM/CGRAM/ICONRAM)
Read Data from RAM	1	1	D7	D6	D5	D4	D3	D2	D1	D0	Read data from internal RAM (DDRAM/CGRAM/ICONRAM)

Instruction table 0(IS[2:1]=[0,0])											
Cursor or Display Shift	0	0	0	0	0	1	S/C	R/L	X	X	S/C and R/L: Set cursor moving and display shift control bit, and the direction, without changing DDRAM data.
Set CGRAM	0	0	0	1	AC5	AC4	AC3	AC2	AC1	AC0	Set CGRAM address in address counter

Instruction table 1(IS[2:1]=[0,1])											
Bias Set	0	0	0	0	0	1	BS	1	0	FX	BS=1:1/4 bias BS=0:1/5 bias FX: fixed on high in 3-line application and fixed on low in other applications.
Set ICON Address	0	0	0	1	0	0	AC3	AC2	AC1	AC0	Set ICON address in address counter.
Power/ICON Control/ Contrast Set	0	0	0	1	0	1	Ion	Bon	C5	C4	Ion: ICON display on/off Bon: set booster circuit on/off C5,C4: Contrast set for internal follower mode.
Follower Control	0	0	0	1	1	0	Fon	Rab2	Rab1	Rab0	Fon: set follower circuit on/off Rab2~0: select follower amplified ratio.
Contrast Set	0	0	0	1	1	1	C3	C2	C1	C0	Contrast set for internal follower mode.

Instruction table 2(IS[2:1]=[1,0])											
Double Height Position Select	0	0	0	0	0	1	UD	X	x	x	UD: Double height position select
Reserved	0	0	0	1	X	X	X	X	X	X	Do not use (reserved for test)

Display character address code:

1	2	3	4	5	6	7	8	9	10	11	12	13	14	15	16
00	01	02	03	04	05	06	07	08	09	0A	0B	0C	0D	0E	0F
40	41	42	43	44	45	46	47	48	49	4A	4B	4C	4D	4E	4F

Built-in Font Table (OPR1 = 0, OPR2 = 0)

b7-b4 b3-b0	0000	0001	0010	0011	0100	0101	0110	0111	1000	1001	1010	1011	1100	1101	1110	1111
0000																
0001																
0010																
0011																
0100																
0101																
0110																
0111																
1000																
1001																
1010																
1011																
1100																
1101																
1110																
1111																

Example Initialization Program

```

/*****
*           Initialization For ST7036i           *
*****/
void init_LCD()
{
I2C_Start();
I2C_out(Slave);//Slave=0x78
I2C_out(Comsend);//Comsend = 0x00
I2C_out(0x38);
delay(10);
I2C_out(0x39);
delay(10);
I2C_out(0x14);
I2C_out(0x78);
I2C_out(0x5E);
I2C_out(0x6D);
I2C_out(0x0C);
I2C_out(0x01);
I2C_out(0x06);
delay(10);
I2C_Stop();
}
/*****/

/*****
*           Output command or data via I2C           *
*****/
void I2C_out(unsigned char j)           //I2C Output
{
    int n;
    unsigned char d;
    d=j;
    for(n=0;n<8;n++){
        if((d&0x80)==0x80)
            SDA=1;
        else
            SDA=0;
        d=(d<<1);
        SCL = 0;
        SCL = 1;
        SCL = 0;
    }
    SCL = 1;
    while(SDA==1){
        SCL=0;
        SCL=1;
    }
    SCL=0;
}
/*****/

/*****
*           I2C Start           *
*****/

```

```

*****/
void I2C_Start(void)
{
    SCL=1;
    SDA=1;
    SDA=0;
    SCL=0;
}
/*****/

/*****
*           I2C Stop                               *
*****/
void I2C_Stop(void)
{
    SDA=0;
    SCL=0;
    SCL=1;
    SDA=1;
}
/*****/

/*****
*           Send string of ASCII data to LCD       *
*****/
void Show(unsigned char *text)
{
    int n,d;
    d=0x00;
    I2C_Start();
    I2C_out(Slave); //Slave=0x78
    I2C_out(Datasend); //Datasend=0x40
    for(n=0;n<20;n++){
        I2C_out(*text);
        ++text;
    }
    I2C_Stop();
}
/*****/
/*****/
/*****/

```

Quality Information

Test Item	Content of Test	Test Condition	Note
High Temperature storage	Endurance test applying the high storage temperature for a long time.	+80°C , 200hrs	2
Low Temperature storage	Endurance test applying the low storage temperature for a long time.	-30°C , 200hrs	1,2
High Temperature Operation	Endurance test applying the electric stress (voltage & current) and the high thermal stress for a long time.	+70°C 200hrs	2
Low Temperature Operation	Endurance test applying the electric stress (voltage & current) and the low thermal stress for a long time.	-20°C , 200hrs	1,2
High Temperature / Humidity Operation	Endurance test applying the electric stress (voltage & current) and the high thermal with high humidity stress for a long time.	+60°C , 90% RH , 96hrs	1,2
Thermal Shock resistance	Endurance test applying the electric stress (voltage & current) during a cycle of low and high thermal stress.	-20°C,30min -> 25°C,5min -> 70°C,30min = 1 cycle 10 cycles	
Vibration test	Endurance test applying vibration to simulate transportation and use.	10-55Hz , 15mm amplitude. 60 sec in each of 3 directions X,Y,Z For 15 minutes	3
Static electricity test	Endurance test applying electric static discharge.	VS=800V, RS=1.5kΩ, CS=100pF One time	

Note 1: No condensation to be observed.

Note 2: Conducted after 4 hours of storage at 25°C, 0%RH.

Note 3: Test performed on product itself, not inside a container.

Precautions for using LCDs/LCMs

See Precautions at www.newhavendisplay.com/specs/precautions.pdf

Warranty Information and Terms & Conditions

http://www.newhavendisplay.com/index.php?main_page=terms