

High Voltage Dual EL Lamp Driver for Low Noise Applications

Features

- ▶ Patented audible noise reduction
- ▶ Patented lamp aging compensation
- ▶ 210 V_{PP} output voltage for higher brightness
- ▶ Patented output timing for high efficiency
- ▶ Single cell lithium ion compatible
- ▶ 150nA shutdown current
- ▶ Wide input voltage range 1.8V to 5.0V
- ▶ Separately adjustable lamp and converter frequencies
- ▶ Output voltage regulation
- ▶ Split supply capability

Applications

- ▶ LCD backlighting
- ▶ Mobile Cellular Phone keypads
- ▶ PDAs
- ▶ Handheld wireless communication products
- ▶ Global Positioning Systems (GPS)

General Description

The Supertex HV832 is a high voltage driver designed for driving two EL lamps with a combined area of 3.5in². The input supply voltage range is from 2.0V to 5.0V. The device is designed to reduce the amount of audible noise emitted by the lamp. It uses a single inductor and a minimum number of passive components. The nominal regulated output voltage that is applied to the EL lamp is $\pm 90V$.

The HV832 has an internal oscillator, a switching MOSFET, and two high voltage EL lamp drivers. The frequency for the switching MOSFET is set at 51KHz nominal. The EL lamp driver frequency is set by dividing the MOSFET switching frequency by 128. An external inductor is connected between the LX and VDD or VIN pins for split supply applications. A 0.001 to 0.01 μF , 100V capacitor is connected between the CS pin and Ground. The EL lamps are connected between EL1 to Com and EL2 to Com.

An input control pin is available to select various modes of the device. Each logic pulse applied to the control pin will cause the device to change to the next mode. The sequence for the modes is: (1) EL1 on only, (2) EL2 on only, (3) both EL1 and EL2 on, and (4) device shuts down. During power up of the device, the mode will default to shut down.

The switching MOSFET charges the external inductor and discharges it into the capacitor at CS. The voltage at CS will start to increase. Once the voltage at CS reaches a nominal value of 90V, the switching MOSFET is turned off to conserve power. The outputs EL1 to Com and EL2 to Com are configured as H bridges EL1/EL2 and Com and are switching in opposite states to achieve 180V across the EL lamp.

Typical Application Circuit

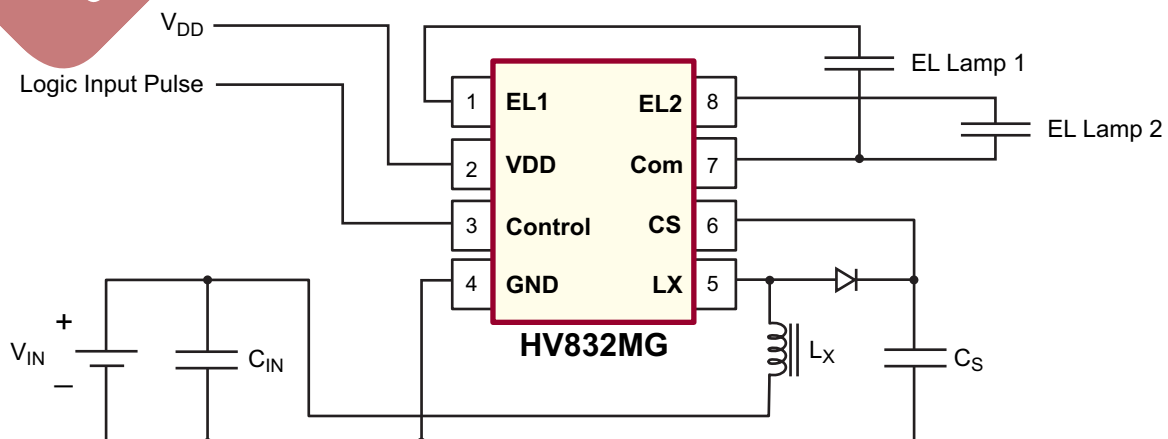

Ordering Information

Device	Package Options	
	MSOP-8 ¹	
HV832	HV832MG	HV832MG-G

¹-G indicates package is RoHS compliant ('Green')



Pin Configuration

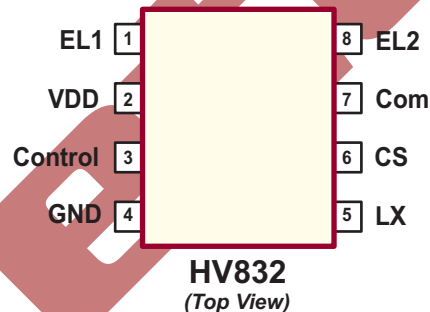

Absolute Maximum Ratings

Parameter	Value
Supply voltage V_{DD}	-0.5V to 7.5V
Output voltage, V_{CS}	-0.5V to 125V
Operating Temperature	-40°C to +85°C
Storage Temperature	-65°C to +150°C
Power Dissipation MSOP-8	300mW

Absolute Maximum Ratings are those values beyond which damage to the device may occur. Functional operation under these conditions is not implied. Continuous operation of the device at the absolute rating level may affect device reliability. All voltages are referenced to device ground.

Recommended Operating Conditions

Sym	Parameter	Min	Typ	Max	Units	Conditions
V_{DD}	Supply voltage	2.0	-	5.0	V	---
T_A	Operating Temperature	-40	-	+85	°C	---

DC Electrical Characteristics (Over recommended operating conditions unless otherwise specified $V_{IN} = V_{DD} = 3.3V$, $T_A = 25^\circ C$)

Sym	Parameter	Min	Typ	Max	Units	Conditions
$R_{DS(ON)}$	On-resistance of switching transistor	-	-	6.0	Ω	$I = 100mA$
V_{CS}	Max. output regulation voltage	80	90	100	V	$V_{DD} = 2.0V$ to $5.0V$
V_{DIFF}	Peak to Peak output voltage	160	180	200	V	$V_{DD} = 2.0V$ to $5.0V$
I_{DDQ}	Quiescent V_{DD} supply current	-	-	150	nA	---
I_{DD}	Input current going into the V_{DD} pin	-	-	150	μA	$V_{DD} = 2.0V$ to $5.0V$.
I_{IN}	Input current including inductor current	-	27	32	mA	$V_{IN} = 3.0V$. Driving EL_1 or EL_2 . See Fig1.*
		-	38	43		$V_{IN} = 3.0V$. Driving both EL_1 and EL_2 . See Fig1.*
V_{CS}	Output voltage on V_{CS}	68	78	87	V	$V_{IN} = 3.0V$. Driving EL_1 or EL_2 . See Fig1.*
		62	70	78		$V_{IN} = 3.0V$. Driving both EL_1 and EL_2 . See Fig1.*
f_{EL}	V_{DIFF} output drive frequency	350	400	450	Hz	$V_{IN} = 3.0V$. See Fig1.*
F_{SW}	Switching transistor frequency	44.8	51.2	57.6	kHz	$V_{IN} = 3.0V$. See Fig1.*
$F_{SW DRIFT}$	Switching transistor frequency drift	-	-	± 5.0	kHz	$T_A = -40^\circ C$ to $+85^\circ C$
D	Switching transistor duty cycle	85	-	-	%	See Fig 1.
I_{IL}	Input logic low current going into the control pin.	-	-	0.6	μA	$V_{DD} = 2.0V$ to $5.0V$. See Fig 1.
I_{IH}	Input logic high current going into the control pin.	-	-	0.6		
V_{IL}	Logic input low voltage	0	-	0.25	V	---
V_{IH}	Logic input high voltage	175	-	V_{DD}	V	---

* The inductor used is a 220 μH Murata inductor, max DC resistance of 8.4 Ω , part # LQH32CN221K21.

Functional Block Diagram

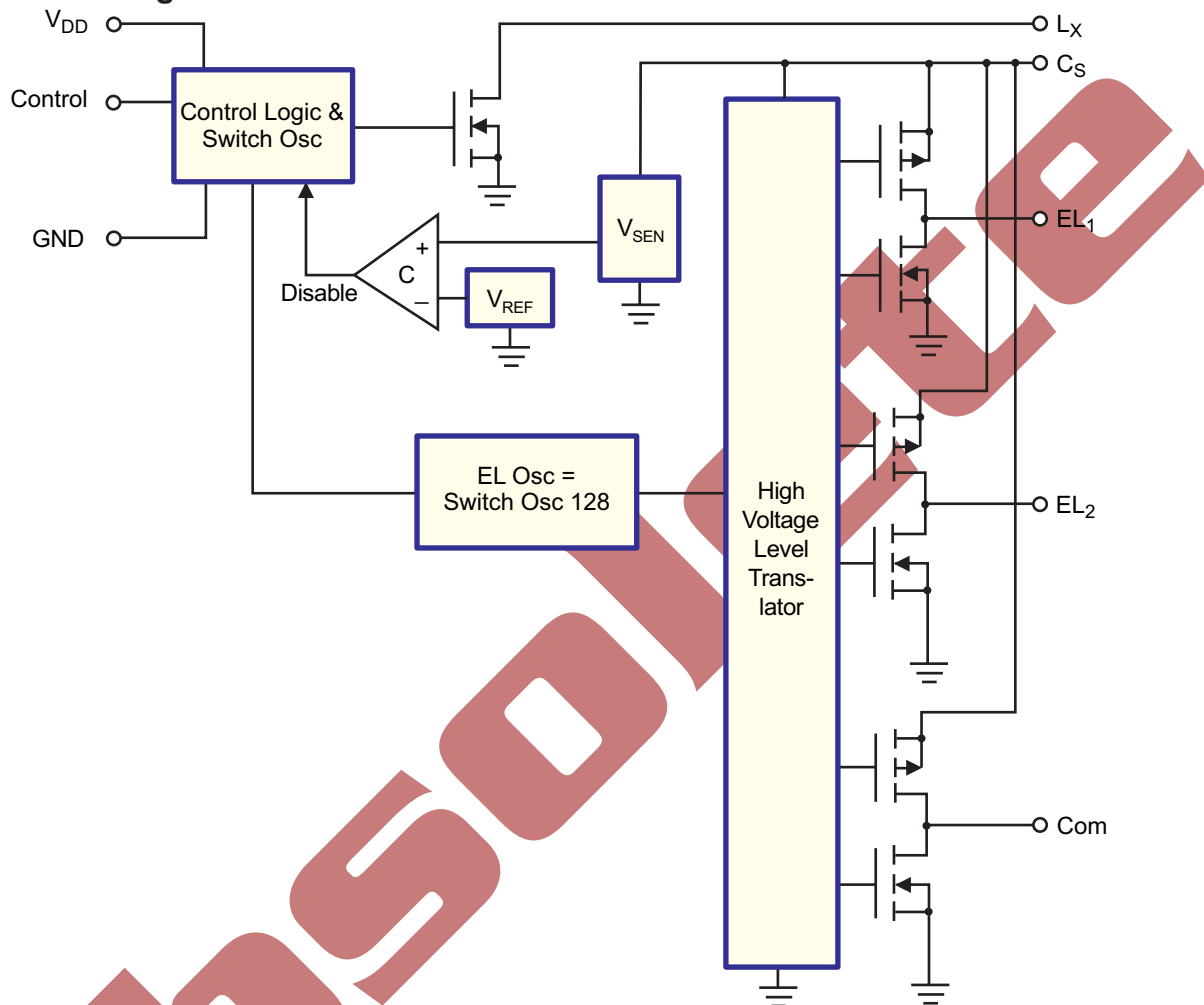

Function Table

Control Pin	EL1	EL2	Com	IC
Power up	HI-Z	HI-Z	HI-Z	OFF
1 _{ST} pulse L to H	ON	HI-Z	ON	ON
2 _{ND} pulse L to H	HI-Z	ON	ON	ON
3 _{RD} pulse L to H	ON	ON	ON	ON
4 _{TH} pulse L to H	HI-Z	HI-Z	HI-Z	OFF

Typical Performance

Device	Lamp	V _{DD}	I _{DD}	V _{CS}	f _{EL}	Brightness
HV832MG	EL ₁ or EL ₂ ON	3.0V	27mA	78V	400Hz	7.5ft-Im
	Both EL ₁ and EL ₂ ON		38mA	70V		6.2ft-Im

Figure 1: Typical Application/Test Circuit

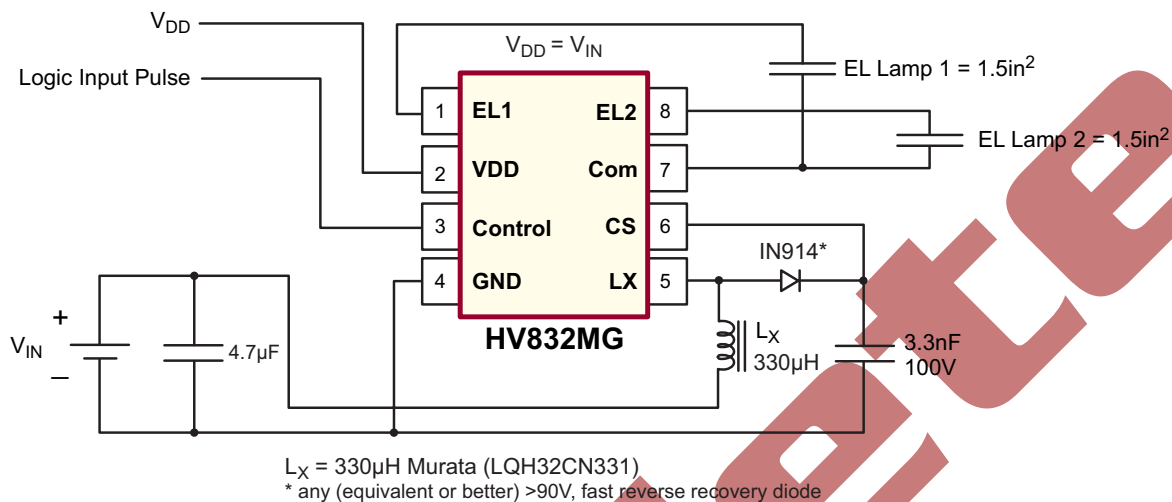

Typical Performance Curves for Fig. 1 (one output on, EL Lamp = 1.5in², $V_{DD} = 3.0\text{V}$)

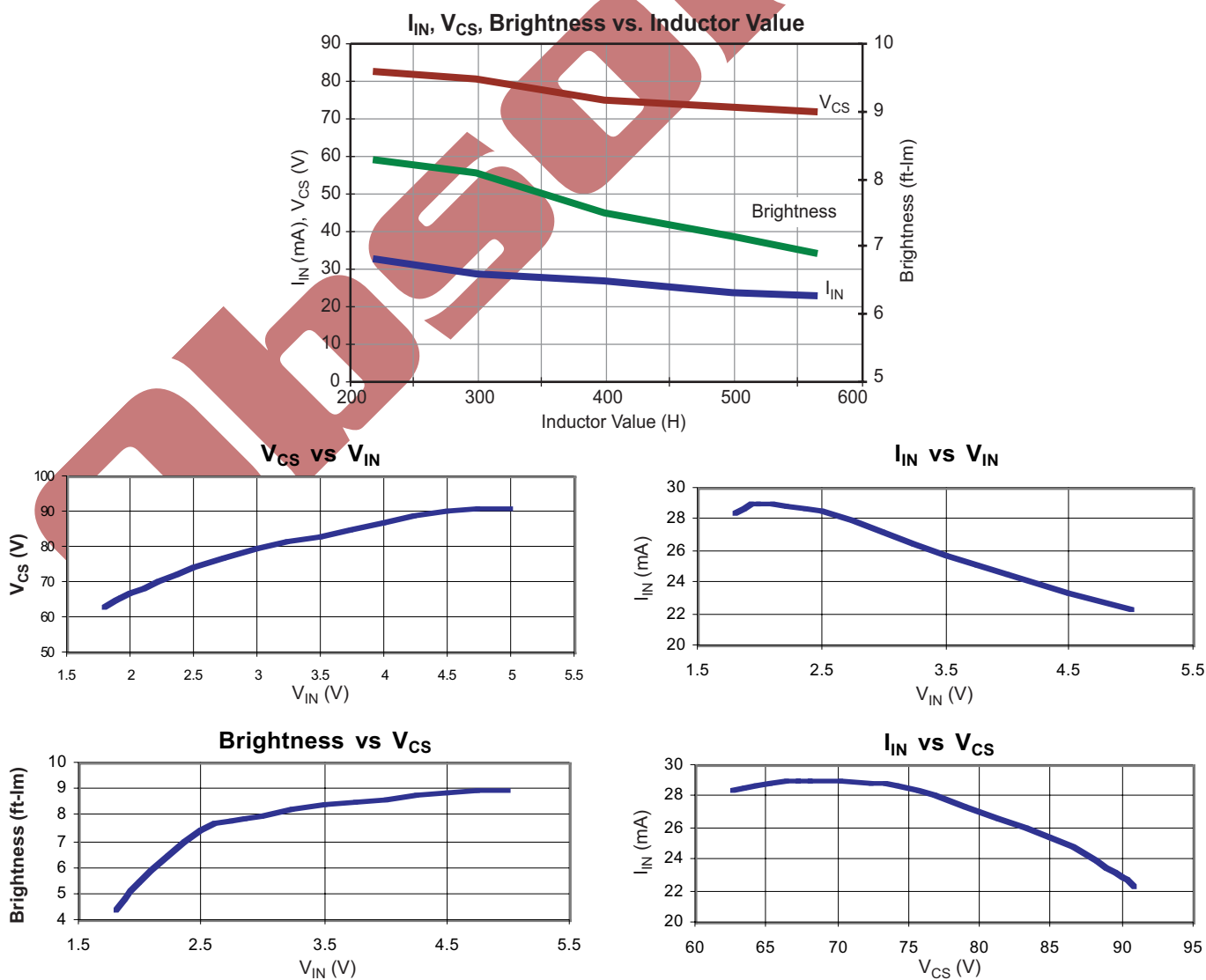

Split Supply Configuration

The HV832 can also be used for handheld devices operating from a battery where a regulated voltage is available. This is shown in Fig. 2. The regulated voltage can be used to run the internal logic of the HV832. The amount of current

necessary to run the internal logic is 150µA Max at a V_{DD} of 3.0V. Therefore, the regulated voltage could easily provide the current without being loaded down.

Fig. 2: Split Supply

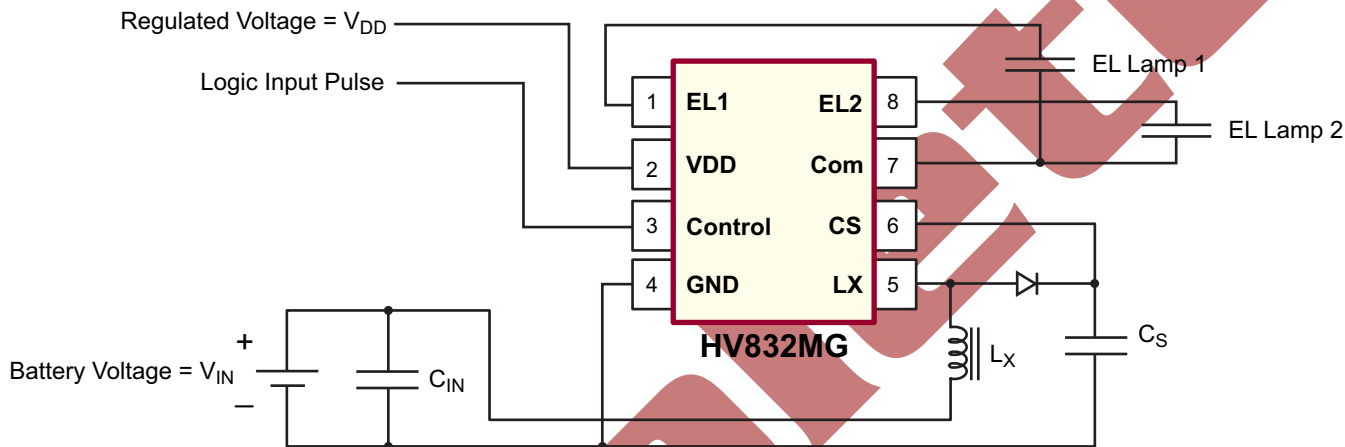

External Component Description

External Component	Selection Guide Line
Diode	Fast reverse recovery diode, IN914 diode or equivalent.
C_s Capacitor	0.003µF to 0.1µF, 200V capacitor to GND is used to store the energy transferred from the inductor.
L_x Inductor	The inductor L_x is used to boost the low input voltage by inductive flyback. When the internal switch is on, the inductor is being charged. When the internal switch is off, the charge stored in the inductor will be transferred to the high voltage capacitor C_s . The energy stored in the capacitor is connected to the internal H-bridge, and therefore to the EL lamp. In general, smaller value inductors, which can handle more current, are more suitable to drive larger size lamps.
Lamp	As the EL lamp size increases, more current will be drawn from the battery to maintain high voltage across the EL lamp. The input power, $(V_{IN} \times I_{IN})$, will also increase. If the input power is greater than the power dissipation of the package (300mW), an external resistor in series with one side of the lamp is recommended to help reduce the package power dissipation.

8-Lead MSOP Package Outline (MG)

3x3mm body, 1.10mm height (max), 0.65mm pitch

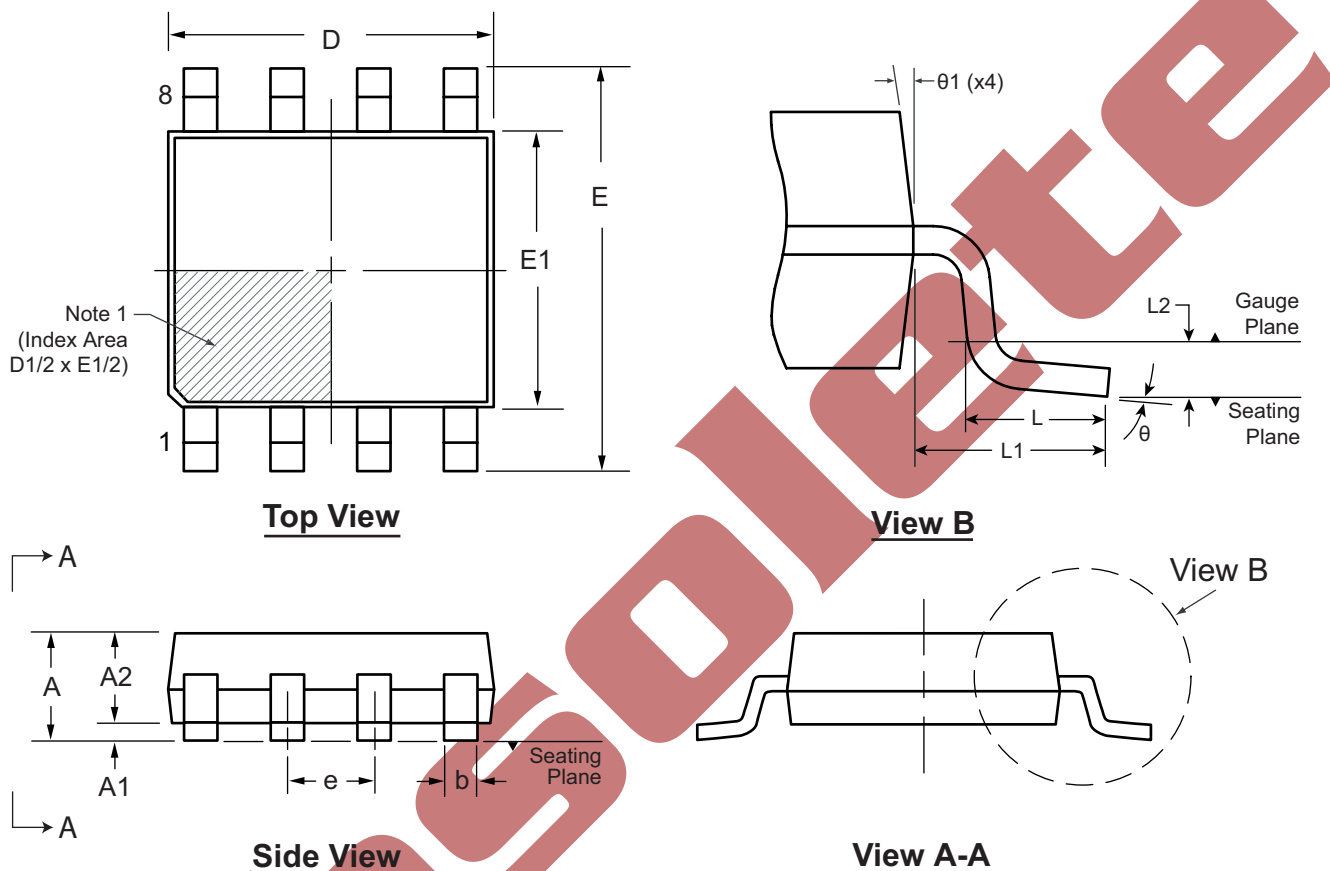

Note 1: A Pin 1 identifier must be located in the index area indicated. The Pin 1 identifier may be either a mold, or an embedded metal or marked feature.

Symbol	A	A1	A2	b	D	E	E1	e	L	L1	L2	θ	$\theta 1$	
Dimension (mm)	MIN	0.75	0.00	0.75	0.22	2.80	4.65	2.80	0.65 BSC	0.40	0.95 REF	0.25 BSC	0°	5°
	NOM	-	-	0.85	-	3.00	4.90	3.00		0.60			-	-
	MAX	1.10	0.15	0.95	0.38	3.20	5.15	3.20		0.80			8°	15°

JEDEC Registration MO-187, Variation AA, Issue E, Dec. 2004.

Drawings not to scale.

(The package drawing(s) in this data sheet may not reflect the most current specifications. For the latest package outline information go to <http://www.supertex.com/packaging.html>.)

Supertex inc. does not recommend the use of its products in life support applications, and will not knowingly sell its products for use in such applications, unless it receives an adequate "product liability indemnification insurance agreement". **Supertex** does not assume responsibility for use of devices described and limits its liability to the replacement of the devices determined defective due to workmanship. No responsibility is assumed for possible omissions or inaccuracies. Circuitry and specifications are subject to change without notice. For the latest product specifications, refer to the **Supertex** website: <http://www.supertex.com>.

©2007 **Supertex inc.** All rights reserved. Unauthorized use or reproduction is prohibited.

Supertex inc.
 1235 Bordeaux Drive, Sunnyvale, CA 94089
 TEL: (408) 222-8888 / FAX: (408) 222-4895
www.supertex.com