

Product Summary Sheet

Low Noise Dual EL Lamp Driver

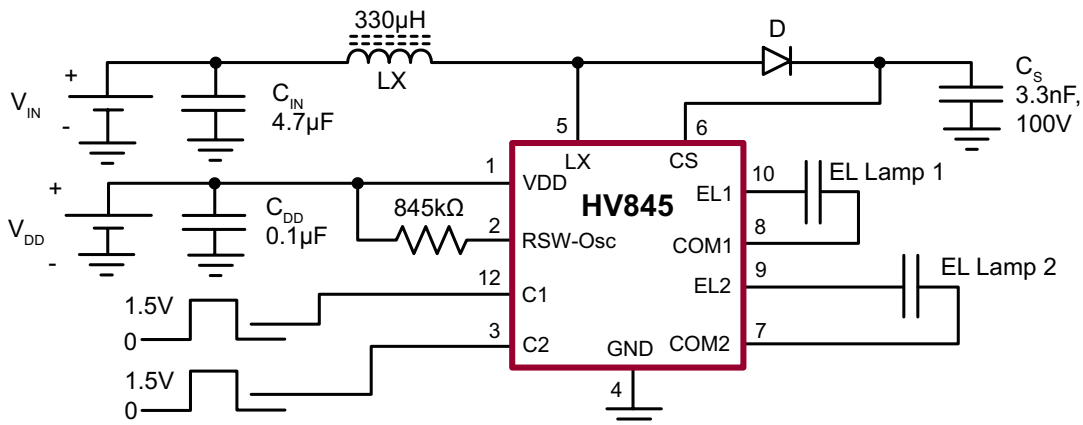

Typical Application Circuit

Applications:

- ▶ Dual display cellular phones
- ▶ Keypad and LCD backlighting
- ▶ Portable instrumentation
- ▶ Dual segment lamps
- ▶ Hand held wireless communication devices



12-Lead QFN/MLP (K7)

Product Overview:

The Supertex HV845 is a high voltage driver designed for driving two EL lamps with a combined area of 3.5 square inches. The input supply voltage range is from 2.0 to 5.8V. The device is designed to reduce the amount of audible noise emitted by the lamp. This device uses a single inductor and minimum number of passive components to drive two EL lamps. The nominal regulated output voltage of $\pm 90V$ is applied to the EL lamps. The two EL lamps can be turned ON and OFF by the two logic input control pins, C1 and C2. The device is disabled when both C1 and C2 (pins 12 and 3) are at logic low.

The HV845 has an internal oscillator, a switching MOSFET, and two high voltage EL lamp drivers. Each driver has its own half bridge common output COM1 and COM2, which significantly minimizes the DC offset seen by the EL lamp. An external resistor connected between the RSW-Osc pin and the voltage supply pin, VDD, sets the frequency for the switching MOSFET. The EL lamp driver frequency is set by dividing the MOSFET switching frequency by 512. An external inductor is connected between the LX and the VDD pins. Depending on the EL lamp size, a 1.0 to 10.0nF, 100V capacitor is connected between CS and GND. The switching MOSFET charges the external inductor and discharges it into the capacitor at CS. The voltage at CS increases. Once the voltage at CS reaches a nominal value of 90V, the switching MOSFET is turned OFF to conserve power.

Features:	Benefits:
Audible noise reduction	Low audible noise levels
Independent input control for lamp selection	Conserves power, extends battery life
180V _{pp} regulated output voltage	Uniform brightness over wide input voltage range
One miniature inductor to power both lamps	Minimal external parts
Low shutdown current	Minimum battery usage while lamp is in standby mode
Wide input voltage range 2.0 to 5.8V	Ease of design with commonly available supply voltages in cellular phones
No SCR output	Eliminates high peak currents into the EL lamp, avoids EMI concerns



062606

Supertex inc.

Low Noise Dual EL Lamp Driver

Ordering Information / Availability

Part Number	Package Option	Samples	Lead Time
HV845K7-G	12-Lead QFN/MLP	Now	4-6 Weeks

-G indicates the part is RoHS compliant (Green).



Product Contact

For any questions regarding the HV845, please contact your local area Supertex sales office, or contact the main office in the US at:

Telephone: 800-222-8888
Fax: 408-222-4895
EMail: mktg@supertex.com
Website: www.supertex.com

Supertex inc.
1235 Bordeaux Drive, Sunnyvale, CA 94089