

Surface Mount Resistor Kits



Features:

- Ring binder surface mount resistor kits.
- 0603, 0805 and 1206 case sizes.
- 5% and 1% tolerance options.
- Available in E6, E12 and E24 series values.
- Kits contain 100 pieces of each ohmic value from 10R to 1M plus 0R.
- All resistors are individually marked and supplied on 8mm tapes.
- Kits can be restocked when required.

Specification Table

Type	Power Rating (W)	Resistance Tolerance	Nominal Resistance
RMC 0805	1/10	F	1K Ω

Ratings:

Type	RMC 0805
Power Rating	0.10W
Maximum Working Voltage	150V
Maximum Overload Voltage	300V
Temperature Range	-55°C +125°C
Ambient Temperature	70°C

Power Rating:

Resistors shall have a power rating based on continuous load operation at an ambient temperature of 70°C. For temperature in excess of 70°C, the load shall be derate.

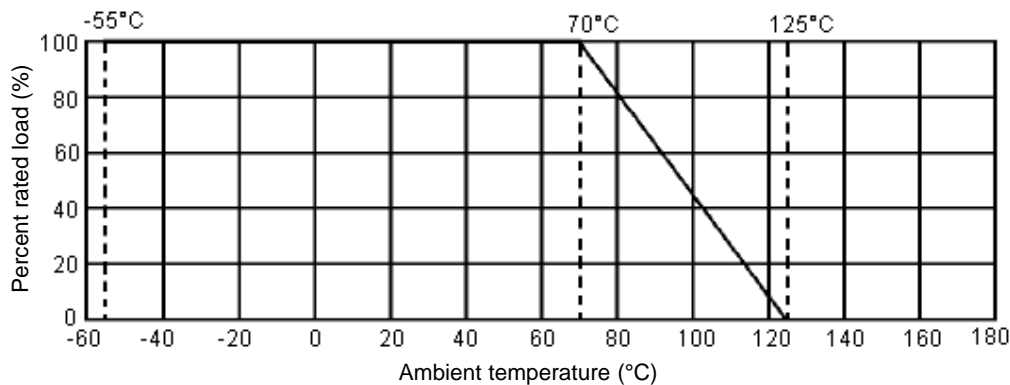

Nominal Resistance

Effective figures of nominal resistance shall be in accordance with E-24, E-96 series for 1% and E-24 series for 2% and 5%.

Surface Mount Resistor Kits



Construction:

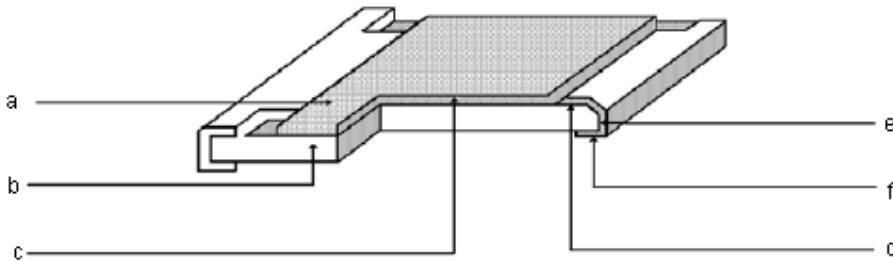

- a. Protective coating: Epoxy
- b. Al_2O_3 high purity alumina substrate: Al 96 %
- c. Resistive element: metal film
- d. Termination (Inner): Ag/Pd
- e. Termination (Between): Ni plating film
- f. Termination (Outer): Sn/Pb plating film

Power Rating and Dimensions:

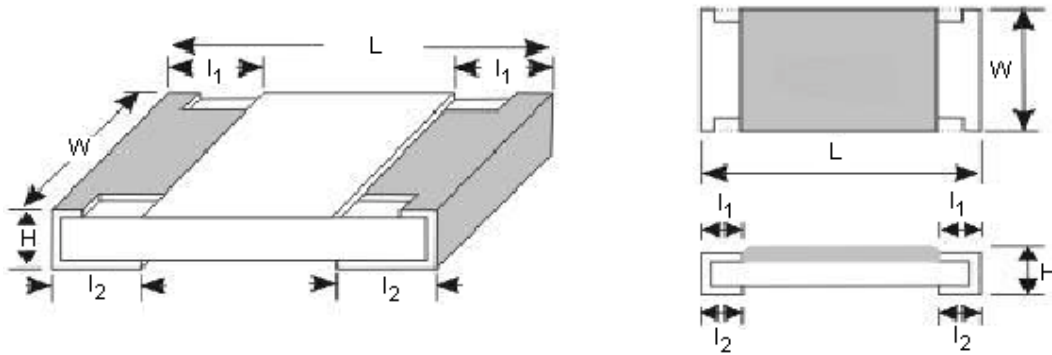

Dimensions : Millimetres

Dimensions

Type	L ± 0.15	W $+0.15$ -0.10	H ± 0.10	$\lambda 1 \pm 0.2$	$\lambda 2 \pm 0.2$
RMC 0805	2.00	1.25	0.55	0.40	0.40

Dimensions : Millimetres

Power Rating

Type	Power Rating at 70°C (W)	Tolerance %	Standard Series
RMC 0805	0.10	± 1	E-24

Surface Mount Resistor Kits



Performance specifications

Characteristics	Limits	Test Methods (JIS C 5201-1)															
Temperature coefficient	10Ω to 100Ω ±200 PPM/°C 101Ω to 1MΩ ±100 PPM/°C	Natural resistance change per temperature degree centigrade $R_2 - R_1 / R_1 (t_2 - t_1) \times 10^6$ (PPM/°C) R ₁ : Resistance value at room temperature (t ₁) R ₂ : Resistance value at room temperature plus 100°C (t ₂)															
Short time overload	Resistance change rate is ±(1.0% + 0.1Ω) Maximum	Permanent resistance change after the application of a potential of 2.5 times RCWV for 5 seconds															
Insulation resistance	1,000MΩ or more	Apply 500V dc between protective coating and termination for 1 minimum, then measure															
Dielectric withstanding voltage	No evidence of flashover mechanical damage, arcing or insulation break down	Apply 500V AC between protective coating and termination for 1 minute															
Terminal bending	±(1.0% + 0.05Ω) Maximum	Twist of test board : Y/X = 5/90mm for 10 seconds															
Temperature cycling	±(0.5% + 0.05Ω) Maximum	Resistance change after continuous 5 cycles for duty cycle specified below: <table border="1" style="margin-left: 20px;"> <thead> <tr> <th>Step</th> <th>Temperature</th> <th>Time</th> </tr> </thead> <tbody> <tr> <td>1</td> <td>-55°C ±3°C</td> <td>30 mins</td> </tr> <tr> <td>2</td> <td>Room temperature</td> <td>10°C 15 mins</td> </tr> <tr> <td>3</td> <td>+125°C ±2°C</td> <td>30 mins</td> </tr> <tr> <td>4</td> <td>Room temperature</td> <td>10°C 15 mins</td> </tr> </tbody> </table>	Step	Temperature	Time	1	-55°C ±3°C	30 mins	2	Room temperature	10°C 15 mins	3	+125°C ±2°C	30 mins	4	Room temperature	10°C 15 mins
Step	Temperature	Time															
1	-55°C ±3°C	30 mins															
2	Room temperature	10°C 15 mins															
3	+125°C ±2°C	30 mins															
4	Room temperature	10°C 15 mins															
Load life in humidity	Resistance change rate is ±(1.0% + 0.1Ω) Maximum	Resistance change after 1,000 hours (1.5 hours "on", 0.5 hour "off") at RCWV in a humidity chamber controlled at 40°C ±2°C and 90 to 95% relative humidity															
Load Life	Resistance change rate is ±(1.0% + 0.05Ω) Maximum	Permanent resistance change after 1,000 hours operating at RCWV, with duty cycle of (1.5 hours "on", 0.5 hour "off") at 70°C ±2°C ambient.															
Soldering Heat	Electrical characteristics shall be satisfied. Without distinct deformation in appearance.	Solder bath method Pre-heat : 100 to 105°C , 30 ±5 seconds Temperature : 265 ± 3°C, 5 +1/-0 seconds Reflow soldering method Peak : 250 +5/-0°C 230°C or higher 30 ±10 seconds Soldering iron method Bit temperature : 350 ±10°C Application time of soldering iron : 3 +1/-0 seconds															
Solderability	95% coverage minimum	Test temperature of solder : 245 ±3°C Dipping them solder : 2 to 3 seconds.															

Surface Mount Resistor Kits



Resistance Preferred Value Range

E6	E12	E24	E96	E6	E12	E24	E96	E6	E12	E24	E96
10	10	10	10.0				21.5				46.4
			10.2	22	22	22	22.1	47	47	47	47.5
			10.5				22.6				48.7
			10.7				23.2				49.9
		11	11.0				23.7			51	51.1
			11.3			24	24.3				52.3
			11.5				24.9				53.6
			11.8				25.5				54.9
	12	12	12.1				26.1	56	56	56	56.2
			12.4				27.7				57.6
			12.7		27	27	27.4				59.0
		13	13.0				28.0				60.4
			13.3				28.7			62	61.9
			13.7				29.4				63.4
			14.0			30	30.1				64.9
			14.3				30.9				66.5
			14.7				31.6	68	68	68	68.1
			15.0				32.4				69.8
15	15	15	15.4	33	33	33	33.2				71.5
			15.8				34.0				73.2
		16	16.2				34.8			75	75.0
			16.5				35.7				76.8
			16.9			36	36.5				78.7
			17.4				37.4				80.6
			17.8				38.3	82	82	82	82.5
	18	18	18.2		39	39	39.2				84.5
			18.7				40.2				86.6
			19.1				41.2				88.7
			19.6				42.2			91	90.9
		20	20.0			43	43.2				93.1
			20.5				44.2				95.3
			21.0				45.3				97.6

Above values in accordance with IEC Publication 63 (1963) and BS2488

Surface Mount Resistor Kits



Part Number Table

Description	Part Number
Resistor Kit, 0603, E24, 1%	0603WGFE240KIT
Resistor Kit, 0603, E6, 5%	0603WGJE060KIT
Resistor Kit, 0603, E12, 5%	0603WGJE120KIT
Resistor Kit, 0805, E24, 1%	0805WAFE240KIT
Resistor Kit, 0805, E12, 5%	0805WAJE120KIT
Resistor Kit, 0805, E24, 5%	0805WAJE240KIT
Resistor Kit, 1206, E24, 1%	1206W8FE240KIT
'Resistor Kit, 1206, E12, 5%	1206W8JE120KIT

Part Number Explanation:

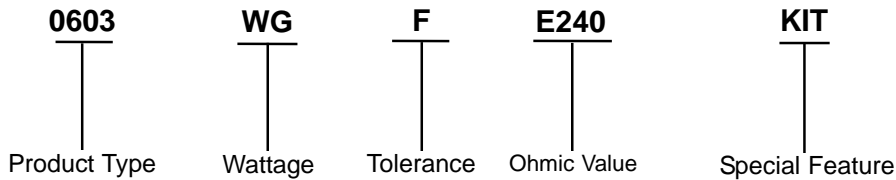

- Wattage** : WG = 1/16W, WA = 1/10W and W8 = 1/8W.
- Tolerance** : F = $\pm 1\%$ and J = $\pm 5\%$.
- Ohmic Value** : Where R = Ohms = Ω .
 K = Kiloohms = K Ω .
 M = Megaohms = M Ω .
 And replaces the decimal point.
 eg: 1R5 = 1.5 Ω .
 4K7 = 4.7K Ω .
 6M8 = 6.8M Ω .
- Special Feature** : KIT = Chip Kit resistor.

Stocked Values

Tolerance	Wattage (W)	Preferred Value Range	Range Value
1%	0.063	E96	1R5 - 1M
1%	0.1	E24	1R5 - 1M
1%	0.125	E24	10R - 1M

Disclaimer This data sheet and its contents (the "Information") belong to the Premier Farnell Group (the "Group") or are licensed to it. No licence is granted for the use of it other than for information purposes in connection with the products to which it relates. No licence of any intellectual property rights is granted. The Information is subject to change without notice and replaces all data sheets previously supplied. The Information supplied is believed to be accurate but the Group assumes no responsibility for its accuracy or completeness, any error in or omission from it or for any use made of it. Users of this data sheet should check for themselves the Information and the suitability of the products for their purpose and not make any assumptions based on information included or omitted. Liability for loss or damage resulting from any reliance on the Information or use of it (including liability resulting from negligence or where the Group was aware of the possibility of such loss or damage arising) is excluded. This will not operate to limit or restrict the Group's liability for death or personal injury resulting from its negligence. SPC Multicomp is the registered trademark of the Group. © Premier Farnell plc 2009.

<http://www.farnell.com>
<http://www.newark.com>
<http://www.cpc.co.uk>

