



ALL RIGHTS RESERVED. NO PORTION OF THIS PUBLICATION, WHETHER IN WHOLE OR IN PART, CAN BE REPRODUCED WITHOUT THE EXPRESS WRITTEN CONSENT OF SPC TECHNOLOGY.

SPC-F005.DWG

REVISIONS

DOC. NO. SPC-F005 * Effective: 7/8/02 * DCP No: 1308

DCP #	REV	DESCRIPTION	DRAWN	DATE	CHECKD	DATE	APPRVD	DATE
1861	A	RELEASED	EYO	11/04/05	HO	11/7/05	JWM	11/7/05
2001	B	Corrected Resistive Element	JN	11/18/08	JWM	11/18/08	JWM	11/18/08

Specifications:

- Power Rating: 1/10 Watt
- Tolerance: 1%
- Max. Working Voltage: 150 V
- Max. Overload Voltage: 500 V
- Temperature Range: -55°C ~ +125°C
- Ambient Temperature: 70°C
- Resistance Range: (See parts label)

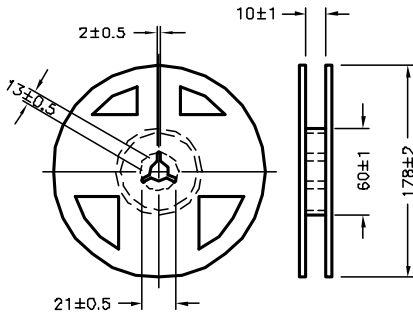
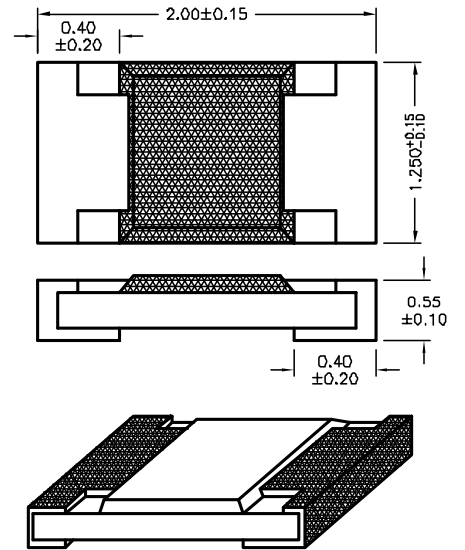
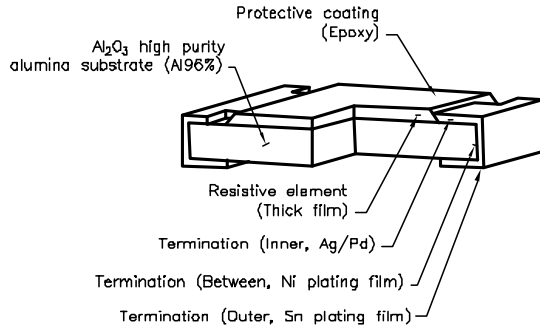

Tape & Reel Dimension

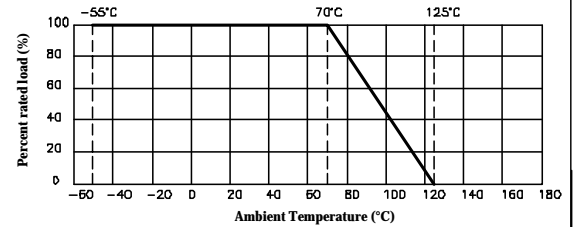
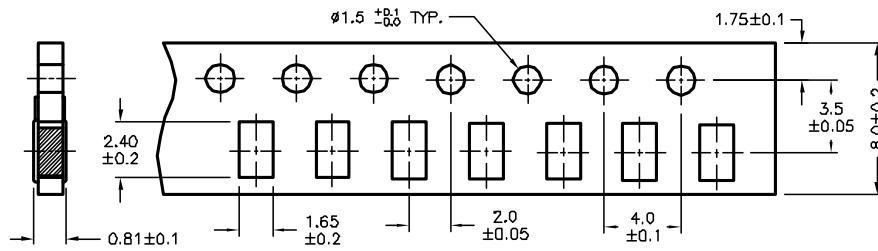

DISCLAIMER: ALL STATEMENTS AND TECHNICAL INFORMATION CONTAINED HEREIN ARE BASED UPON INFORMATION AND/OR TESTS WE BELIEVE TO BE ACCURATE AND RELIABLE. SINCE CONDITIONS OF USE ARE BEYOND OUR CONTROL, THE USER SHALL DETERMINE THE SUITABILITY OF THE PRODUCT FOR THE INTENDED USE AND ASSUME ALL RISK AND LIABILITY WHATSOEVER IN CONNECTION THEREWITH.

TOLERANCES: UNLESS OTHERWISE SPECIFIED, DIMENSIONS ARE FOR REFERENCE PURPOSES ONLY.

DRAWN BY:	DATE:
EKLAS ODISH	11/05/05
CHECKED BY:	DATE:
HISHAM ODISH	11/7/05
APPROVED BY:	DATE:
JEFF MCVICKER	11/7/05

DRAWING TITLE:			
RoHS Compliant Thick Film Chip Resistors, EIA Size 0805, 1/10 Watt			
SIZE	DWG. NO.	ELECTRONIC FILE	REV
A	TA-675	TA-675.DWG	B
SCALE:	NTS	U.Q.M.: Millimeters	SHEET: 1 OF 5

Performance specification

Characteristics	Limits	Test Methods (JIS - C - 5201-1)															
Temperature coefficient	100-100 Ω $\leq \pm 200$ PPM/°C 101 Ω-1MΩ $\leq \pm 100$ PPM/°C	5.2 Natural resistance change per temp. degree centigrade $\frac{R2-R1}{R1(t2-t1)} \times 10^6$ (PPM/°C) R1: Resistance value at room temperature (t1) R2: Resistance value at room temp. plus 100°C (t2)															
Short time overload	Resistance change rate is: $\pm (1.0\% + 0.1 \Omega)$ Max.	5.5 Permanent resistance change after the application of a potential of 2.5 times RCWV for 5 seconds															
Insulation resistance	1,000 MO or more	5.6 Apply 500V DC between protective coating and termination for 1 min, then measure															
Dielectric withstanding voltage	No evidence of flashover mechanical damage, arcing or insulation break down	5.7 Apply 500V AC between protective coating and termination for 1 minute															
Terminal bending	$\pm (1.0\% + 0.05O)$ Max.	6.1.4 Twist of Test Board: Y/X = 5/90 mm for 10 seconds															
Temperature cycling	$\pm (0.5\% + 0.05O)$ Max.	7.4 Resistance change after continuous 5 cycles for duty cycle specified below: <table border="1" style="margin-left: auto; margin-right: auto;"> <thead> <tr> <th>Step</th> <th>Temperature</th> <th>Time</th> </tr> </thead> <tbody> <tr> <td>1</td> <td>-55°C $\pm 3^\circ$C</td> <td>30 mins</td> </tr> <tr> <td>2</td> <td>Room temp.</td> <td>10 - 15 mins</td> </tr> <tr> <td>3</td> <td>-125°C $\pm 2^\circ$C</td> <td>30 mins</td> </tr> <tr> <td>4</td> <td>Room temp.</td> <td>10 - 15 mins</td> </tr> </tbody> </table>	Step	Temperature	Time	1	-55°C $\pm 3^\circ$ C	30 mins	2	Room temp.	10 - 15 mins	3	-125°C $\pm 2^\circ$ C	30 mins	4	Room temp.	10 - 15 mins
Step	Temperature	Time															
1	-55°C $\pm 3^\circ$ C	30 mins															
2	Room temp.	10 - 15 mins															
3	-125°C $\pm 2^\circ$ C	30 mins															
4	Room temp.	10 - 15 mins															
Load life in humidity	Resistance change rate is $\pm (1.0\% + 0.1 \Omega)$ Max.	7.9 Resistance change after 1,000 hours (1.5 hours "on", 0.5 hour "off") at RCWV in a humidity chamber controlled at 40°C $\pm 2^\circ$ C and 90 to 95 % relative humidity															
Load Life	Resistance change rate is $\pm (1.0\% + 0.1 \Omega)$ Max.	7.10 Permanent resistance change after 1,000 hours operating at RCWV, with duty cycle of (1.5 hours"on", 0.5 hour "off") at 70°C $\pm 2^\circ$ C ambient															
Soldering Heat	Electrical characteristics shall be satisfied. Without distinct deformation in appearance.	<u>Solder bath method</u> Pre-heat: 100 to 105°C, 30 \pm 5 sec Temperature: 265 \pm 3°C, 5 + 1/-0 sec. <u>Reflow soldering method</u> Peak: 250 + 5/-0°C 230 °C or higher 30 \pm 10 sec. <u>soldering iron method</u> Bit temperature: 350 \pm 10°C Application time of soldering iron : 3+ 1/-0 sec.															
Solderability	95 % coverage Min.	6.5 Test temperature of solder : 245 °C \pm 3°C Dipping them solder : 2 - 3 seconds															

ALL RIGHTS RESERVED. NO PORTION OF THIS PUBLICATION, WHETHER IN WHOLE OR IN PART CAN BE REPRODUCED WITHOUT THE EXPRESS WRITTEN CONSENT OF SPC TECHNOLOGY.

SIZE DWG. NO.

A

TA-675

ELECTRONIC FILE

TA-675.DWG

REV

A

SPC-F005.DWG

DOC. NO. SPC-F005 * Effective: 7/8/02 * DCP No: 1388

SCALE: NTS

U.Q.M.: Millimeters

SHEET: 2 OF 5

Multicomp Type No	Resistance	Real Size
MC0805WAF100JT5E-TC	10 ohm	Sold by Each
MC0805WAF100JT5E-TR	10 ohm	Sold in Tape and Reel of 5,000
MC0805WAF110JT5E-TC	11 ohm	Sold by Each
MC0805WAF110JT5E-TR	11 ohm	Sold in Tape and Reel of 5,000
MC0805WAF120JT5E-TC	12 ohm	Sold by Each
MC0805WAF120JT5E-TR	12 ohm	Sold in Tape and Reel of 5,000
MC0805WAF150JT5E-TC	15 ohm	Sold by Each
MC0805WAF150JT5E-TR	15 ohm	Sold in Tape and Reel of 5,000
MC0805WAF160JT5E-TC	16 ohm	Sold by Each
MC0805WAF160JT5E-TR	16 ohm	Sold in Tape and Reel of 5,000
MC0805WAF180JT5E-TC	18 ohm	Sold by Each
MC0805WAF180JT5E-TR	18 ohm	Sold in Tape and Reel of 5,000
MC0805WAF200JT5E-TC	20 ohm	Sold by Each
MC0805WAF200JT5E-TR	20 ohm	Sold in Tape and Reel of 5,000
MC0805WAF220JT5E-TC	22 ohm	Sold by Each
MC0805WAF220JT5E-TR	22 ohm	Sold in Tape and Reel of 5,000
MC0805WAF240JT5E-TC	24 ohm	Sold by Each
MC0805WAF240JT5E-TR	24 ohm	Sold in Tape and Reel of 5,000
MC0805WAF270JT5E-TC	27 ohm	Sold by Each
MC0805WAF270JT5E-TR	27 ohm	Sold in Tape and Reel of 5,000
MC0805WAF300JT5E-TC	30 ohm	Sold by Each
MC0805WAF300JT5E-TR	30 ohm	Sold in Tape and Reel of 5,000
MC0805WAF330JT5E-TC	33 ohm	Sold by Each
MC0805WAF330JT5E-TR	33 ohm	Sold in Tape and Reel of 5,000
MC0805WAF360JT5E-TC	36 ohm	Sold by Each
MC0805WAF360JT5E-TR	36 ohm	Sold in Tape and Reel of 5,000
MC0805WAF390JT5E-TC	39 ohm	Sold by Each
MC0805WAF390JT5E-TR	39 ohm	Sold in Tape and Reel of 5,000
MC0805WAF430JT5E-TC	43 ohm	Sold by Each
MC0805WAF430JT5E-TR	43 ohm	Sold in Tape and Reel of 5,000
MC0805WAF470JT5E-TC	47 ohm	Sold by Each
MC0805WAF470JT5E-TR	47 ohm	Sold in Tape and Reel of 5,000
MC0805WAF510JT5E-TC	51 ohm	Sold by Each
MC0805WAF510JT5E-TR	51 ohm	Sold in Tape and Reel of 5,000
MC0805WAF560JT5E-TC	56 ohm	Sold by Each
MC0805WAF560JT5E-TR	56 ohm	Sold in Tape and Reel of 5,000
MC0805WAF620JT5E-TC	62 ohm	Sold by Each
MC0805WAF620JT5E-TR	62 ohm	Sold in Tape and Reel of 5,000
MC0805WAF680JT5E-TC	68 ohm	Sold by Each
MC0805WAF680JT5E-TR	68 ohm	Sold in Tape and Reel of 5,000

Multicomp Type No	Resistance	Real Size
MC0805WAF750JT5E-TC	75 ohm	Sold by Each
MC0805WAF750JT5E-TR	75 ohm	Sold in Tape and Reel of 5,000
MC0805WAF820JT5E-TC	82 ohm	Sold by Each
MC0805WAF820JT5E-TR	82 ohm	Sold in Tape and Reel of 5,000
MC0805WAF910JT5E-TC	91 ohm	Sold by Each
MC0805WAF910JT5E-TR	91 ohm	Sold in Tape and Reel of 5,000
MC0805WAF1000T5E-TC	100 ohm	Sold by Each
MC0805WAF1000T5E-TR	100 ohm	Sold in Tape and Reel of 5,000
MC0805WAF1100T5E-TC	110 ohm	Sold by Each
MC0805WAF1100T5E-TR	110 ohm	Sold in Tape and Reel of 5,000
MC0805WAF1200T5E-TC	120 ohm	Sold by Each
MC0805WAF1200T5E-TR	120 ohm	Sold in Tape and Reel of 5,000
MC0805WAF1300T5E-TC	130 ohm	Sold by Each
MC0805WAF1300T5E-TR	130 ohm	Sold in Tape and Reel of 5,000
MC0805WAF1500T5E-TC	150 ohm	Sold by Each
MC0805WAF1500T5E-TR	150 ohm	Sold in Tape and Reel of 5,000
MC0805WAF1600T5E-TC	160 ohm	Sold by Each
MC0805WAF1600T5E-TR	160 ohm	Sold in Tape and Reel of 5,000
MC0805WAF1800T5E-TC	180 ohm	Sold by Each
MC0805WAF1800T5E-TR	180 ohm	Sold in Tape and Reel of 5,000
MC0805WAF2000T5E-TC	200 ohm	Sold by Each
MC0805WAF2000T5E-TR	200 ohm	Sold in Tape and Reel of 5,000
MC0805WAF2200T5E-TC	220 ohm	Sold by Each
MC0805WAF2200T5E-TR	220 ohm	Sold in Tape and Reel of 5,000
MC0805WAF2400T5E-TC	240 ohm	Sold by Each
MC0805WAF2400T5E-TR	240 ohm	Sold in Tape and Reel of 5,000
MC0805WAF2700T5E-TC	270 ohm	Sold by Each
MC0805WAF2700T5E-TR	270 ohm	Sold in Tape and Reel of 5,000
MC0805WAF3000T5E-TC	300 ohm	Sold by Each
MC0805WAF3000T5E-TR	300 ohm	Sold in Tape and Reel of 5,000
MC0805WAF3300T5E-TC	330 ohm	Sold by Each
MC0805WAF3300T5E-TR	330 ohm	Sold in Tape and Reel of 5,000
MC0805WAF3600T5E-TC	360 ohm	Sold by Each
MC0805WAF3600T5E-TR	360 ohm	Sold in Tape and Reel of 5,000
MC0805WAF3900T5E-TC	390 ohm	Sold by Each
MC0805WAF3900T5E-TR	390 ohm	Sold in Tape and Reel of 5,000
MC0805WAF4300T5E-TC	430 ohm	Sold by Each
MC0805WAF4300T5E-TR	430 ohm	Sold in Tape and Reel of 5,000
MC0805WAF4700T5E-TC	470 ohm	Sold by Each
MC0805WAF4700T5E-TR	470 ohm	Sold in Tape and Reel of 5,000

ALL RIGHTS RESERVED. NO PORTION OF THIS PUBLICATION, WHETHER IN WHOLE OR IN PART CAN BE REPRODUCED WITHOUT THE EXPRESS WRITTEN CONSENT OF SPC TECHNOLOGY.

SIZE DWG. NO.

A TA-675

ELECTRONIC FILE

TA-675.DWG

REV

A

SPC-F005.DWG

DOC. NO. SPC-F005 * Effective: 7/8/02 * DCP No: 1388

SCALE: NTS

U.Q.M.: Millimeters

SHEET: 3 OF 5

Multicomp Type No	Resistance	Real Size
MCOB05WAF5100T5E-TC	510 ohm	Sold by Each
MCOB05WAF5100T5E-TR	510 ohm	Sold in Tape and Reel of 5,000
MCOB05WAF5600T5E-TC	560 ohm	Sold by Each
MCOB05WAF5600T5E-TR	560 ohm	Sold in Tape and Reel of 5,000
MCOB05WAF6200T5E-TC	620 ohm	Sold by Each
MCOB05WAF6200T5E-TR	620 ohm	Sold in Tape and Reel of 5,000
MCOB05WAF6800T5E-TC	680 ohm	Sold by Each
MCOB05WAF6800T5E-TR	680 ohm	Sold in Tape and Reel of 5,000
MCOB05WAF7500T5E-TC	750 ohm	Sold by Each
MCOB05WAF7500T5E-TR	750 ohm	Sold in Tape and Reel of 5,000
MCOB05WAF8200T5E-TC	820 ohm	Sold by Each
MCOB05WAF8200T5E-TR	820 ohm	Sold in Tape and Reel of 5,000
MCOB05WAF9100T5E-TC	910 ohm	Sold by Each
MCOB05WAF9100T5E-TR	910 ohm	Sold in Tape and Reel of 5,000
MCOB05WAF1001T5E-TC	1 Kohm	Sold by Each
MCOB05WAF1001T5E-TR	1 Kohm	Sold in Tape and Reel of 5,000
MCOB05WAF1101T5E-TC	1.1 Kohm	Sold by Each
MCOB05WAF1101T5E-TR	1.1 Kohm	Sold in Tape and Reel of 5,000
MCOB05WAF1201T5E-TC	1.2 Kohm	Sold by Each
MCOB05WAF1201T5E-TR	1.2 Kohm	Sold in Tape and Reel of 5,000
MCOB05WAF1301T5E-TC	1.3 Kohm	Sold by Each
MCOB05WAF1301T5E-TR	1.3 Kohm	Sold in Tape and Reel of 5,000
MCOB05WAF1501T5E-TC	1.5 Kohm	Sold by Each
MCOB05WAF1501T5E-TR	1.5 Kohm	Sold in Tape and Reel of 5,000
MCOB05WAF1601T5E-TC	1.6 Kohm	Sold by Each
MCOB05WAF1601T5E-TR	1.6 Kohm	Sold in Tape and Reel of 5,000
MCOB05WAF1801T5E-TC	1.8 Kohm	Sold by Each
MCOB05WAF1801T5E-TR	1.8 Kohm	Sold in Tape and Reel of 5,000
MCOB05WAF2001T5E-TC	2 Kohm	Sold by Each
MCOB05WAF2001T5E-TR	2 Kohm	Sold in Tape and Reel of 5,000
MCOB05WAF2201T5E-TC	2.2 Kohm	Sold by Each
MCOB05WAF2201T5E-TR	2.2 Kohm	Sold in Tape and Reel of 5,000
MCOB05WAF2401T5E-TC	2.4 Kohm	Sold by Each
MCOB05WAF2401T5E-TR	2.4 Kohm	Sold in Tape and Reel of 5,000
MCOB05WAF2701T5E-TC	2.7 Kohm	Sold by Each
MCOB05WAF2701T5E-TR	2.7 Kohm	Sold in Tape and Reel of 5,000
MCOB05WAF3001T5E-TC	3 Kohm	Sold by Each
MCOB05WAF3001T5E-TR	3 Kohm	Sold in Tape and Reel of 5,000
MCOB05WAF3301T5E-TC	3.3 Kohm	Sold by Each
MCOB05WAF3301T5E-TR	3.3 Kohm	Sold in Tape and Reel of 5,000

Multicomp Type No	Resistance	Real Size
MCOB05WAF3601T5E-TC	3.6 Kohm	Sold by Each
MCOB05WAF3601T5E-TR	3.6 Kohm	Sold in Tape and Reel of 5,000
MCOB05WAF3901T5E-TC	3.9 Kohm	Sold by Each
MCOB05WAF3901T5E-TR	3.9 Kohm	Sold in Tape and Reel of 5,000
MCOB05WAF4301T5E-TC	4.3 Kohm	Sold by Each
MCOB05WAF4301T5E-TR	4.3 Kohm	Sold in Tape and Reel of 5,000
MCOB05WAF4701T5E-TC	4.7 Kohm	Sold by Each
MCOB05WAF4701T5E-TR	4.7 Kohm	Sold in Tape and Reel of 5,000
MCOB05WAF5101T5E-TC	5.1 Kohm	Sold by Each
MCOB05WAF5101T5E-TR	5.1 Kohm	Sold in Tape and Reel of 5,000
MCOB05WAF5601T5E-TC	5.6 Kohm	Sold by Each
MCOB05WAF5601T5E-TR	5.6 Kohm	Sold in Tape and Reel of 5,000
MCOB05WAF6201T5E-TC	6.2 Kohm	Sold by Each
MCOB05WAF6201T5E-TR	6.2 Kohm	Sold in Tape and Reel of 5,000
MCOB05WAF6801T5E-TC	6.8 Kohm	Sold by Each
MCOB05WAF6801T5E-TR	6.8 Kohm	Sold in Tape and Reel of 5,000
MCOB05WAF7501T5E-TC	7.5 Kohm	Sold by Each
MCOB05WAF7501T5E-TR	7.5 Kohm	Sold in Tape and Reel of 5,000
MCOB05WAF8201T5E-TC	8.2 Kohm	Sold by Each
MCOB05WAF8201T5E-TR	8.2 Kohm	Sold in Tape and Reel of 5,000
MCOB05WAF9101T5E-TC	9.1 Kohm	Sold by Each
MCOB05WAF9101T5E-TR	9.1 Kohm	Sold in Tape and Reel of 5,000
MCOB05WAF1002T5E-TC	10 Kohm	Sold by Each
MCOB05WAF1002T5E-TR	10 Kohm	Sold in Tape and Reel of 5,000
MCOB05WAF1102T5E-TC	11 Kohm	Sold by Each
MCOB05WAF1102T5E-TR	11 Kohm	Sold in Tape and Reel of 5,000
MCOB05WAF1202T5E-TC	12 Kohm	Sold by Each
MCOB05WAF1202T5E-TR	12 Kohm	Sold in Tape and Reel of 5,000
MCOB05WAF1302T5E-TC	13 Kohm	Sold by Each
MCOB05WAF1302T5E-TR	13 Kohm	Sold in Tape and Reel of 5,000
MCOB05WAF1502T5E-TC	15 Kohm	Sold by Each
MCOB05WAF1502T5E-TR	15 Kohm	Sold in Tape and Reel of 5,000
MCOB05WAF1602T5E-TC	16 Kohm	Sold by Each
MCOB05WAF1602T5E-TR	16 Kohm	Sold in Tape and Reel of 5,000
MCOB05WAF1802T5E-TC	18 Kohm	Sold by Each
MCOB05WAF1802T5E-TR	18 Kohm	Sold in Tape and Reel of 5,000
MCOB05WAF2002T5E-TC	20 Kohm	Sold by Each
MCOB05WAF2002T5E-TR	20 Kohm	Sold in Tape and Reel of 5,000
MCOB05WAF2202T5E-TC	22 Kohm	Sold by Each
MCOB05WAF2202T5E-TR	22 Kohm	Sold in Tape and Reel of 5,000

ALL RIGHTS RESERVED. NO PORTION OF THIS PUBLICATION, WHETHER IN WHOLE OR IN PART CAN BE REPRODUCED WITHOUT THE EXPRESS WRITTEN CONSENT OF SPC TECHNOLOGY.

SIZE DWG. NO.

A TA-675

ELECTRONIC FILE

TA-675.DWG

REV

A

SPC-F005.DWG

DOC. NO. SPC-F005 * Effective: 7/8/02 * DCP No: 1388

SCALE: NTS

U.Q.M.: Millimeters

SHEET: 4 OF 5

Multicomp Type No	Resistance	Real Size
MCOB05WAF2402T5E-TC	24 Kohm	Sold by Each
MCOB05WAF2402T5E-TR	24 Kohm	Sold in Tape and Reel of 5,000
MCOB05WAF2702T5E-TC	27 Kohm	Sold by Each
MCOB05WAF2702T5E-TR	27 Kohm	Sold in Tape and Reel of 5,000
MCOB05WAF3002T5E-TC	30 Kohm	Sold by Each
MCOB05WAF3002T5E-TR	30 Kohm	Sold in Tape and Reel of 5,000
MCOB05WAF3302T5E-TC	33 Kohm	Sold by Each
MCOB05WAF3302T5E-TR	33 Kohm	Sold in Tape and Reel of 5,000
MCOB05WAF3602T5E-TC	36 Kohm	Sold by Each
MCOB05WAF3602T5E-TR	36 Kohm	Sold in Tape and Reel of 5,000
MCOB05WAF3902T5E-TC	39 Kohm	Sold by Each
MCOB05WAF3902T5E-TR	39 Kohm	Sold in Tape and Reel of 5,000
MCOB05WAF4302T5E-TC	43 Kohm	Sold by Each
MCOB05WAF4302T5E-TR	43 Kohm	Sold in Tape and Reel of 5,000
MCOB05WAF4702T5E-TC	47 Kohm	Sold by Each
MCOB05WAF4702T5E-TR	47 Kohm	Sold in Tape and Reel of 5,000
MCOB05WAF5102T5E-TC	51 Kohm	Sold by Each
MCOB05WAF5102T5E-TR	51 Kohm	Sold in Tape and Reel of 5,000
MCOB05WAF5602T5E-TC	56 Kohm	Sold by Each
MCOB05WAF5602T5E-TR	56 Kohm	Sold in Tape and Reel of 5,000
MCOB05WAF6202T5E-TC	62 Kohm	Sold by Each
MCOB05WAF6202T5E-TR	62 Kohm	Sold in Tape and Reel of 5,000
MCOB05WAF6802T5E-TC	68 Kohm	Sold by Each
MCOB05WAF6802T5E-TR	68 Kohm	Sold in Tape and Reel of 5,000
MCOB05WAF7502T5E-TC	75 Kohm	Sold by Each
MCOB05WAF7502T5E-TR	75 Kohm	Sold in Tape and Reel of 5,000
MCOB05WAF8202T5E-TC	82 Kohm	Sold by Each
MCOB05WAF8202T5E-TR	82 Kohm	Sold in Tape and Reel of 5,000
MCOB05WAF9102T5E-TC	91 Kohm	Sold by Each
MCOB05WAF9102T5E-TR	91 Kohm	Sold in Tape and Reel of 5,000
MCOB05WAF1003T5E-TC	100 Kohm	Sold by Each
MCOB05WAF1003T5E-TR	100 Kohm	Sold in Tape and Reel of 5,000
MCOB05WAF1103T5E-TC	110 Kohm	Sold by Each
MCOB05WAF1103T5E-TR	110 Kohm	Sold in Tape and Reel of 5,000
MCOB05WAF1203T5E-TC	120 Kohm	Sold by Each
MCOB05WAF1203T5E-TR	120 Kohm	Sold in Tape and Reel of 5,000
MCOB05WAF1303T5E-TC	130 Kohm	Sold by Each
MCOB05WAF1303T5E-TR	130 Kohm	Sold in Tape and Reel of 5,000
MCOB05WAF1503T5E-TC	150 Kohm	Sold by Each
MCOB05WAF1503T5E-TR	150 Kohm	Sold in Tape and Reel of 5,000

Multicomp Type No	Resistance	Real Size
MCOB05WAF1603T5E-TC	160 Kohm	Sold by Each
MCOB05WAF1603T5E-TR	160 Kohm	Sold in Tape and Reel of 5,000
MCOB05WAF1803T5E-TC	180 Kohm	Sold by Each
MCOB05WAF1803T5E-TR	180 Kohm	Sold in Tape and Reel of 5,000
MCOB05WAF2003T5E-TC	200 Kohm	Sold by Each
MCOB05WAF2003T5E-TR	200 Kohm	Sold in Tape and Reel of 5,000
MCOB05WAF2203T5E-TC	220 Kohm	Sold by Each
MCOB05WAF2203T5E-TR	220 Kohm	Sold in Tape and Reel of 5,000
MCOB05WAF2403T5E-TC	240 Kohm	Sold by Each
MCOB05WAF2403T5E-TR	240 Kohm	Sold in Tape and Reel of 5,000
MCOB05WAF2703T5E-TC	270 Kohm	Sold by Each
MCOB05WAF2703T5E-TR	270 Kohm	Sold in Tape and Reel of 5,000
MCOB05WAF3003T5E-TC	300 Kohm	Sold by Each
MCOB05WAF3003T5E-TR	300 Kohm	Sold in Tape and Reel of 5,000
MCOB05WAF3303T5E-TC	330 Kohm	Sold by Each
MCOB05WAF3303T5E-TR	330 Kohm	Sold in Tape and Reel of 5,000
MCOB05WAF3603T5E-TC	360 Kohm	Sold by Each
MCOB05WAF3603T5E-TR	360 Kohm	Sold in Tape and Reel of 5,000
MCOB05WAF3903T5E-TC	390 Kohm	Sold by Each
MCOB05WAF3903T5E-TR	390 Kohm	Sold in Tape and Reel of 5,000
MCOB05WAF4303T5E-TC	430 Kohm	Sold by Each
MCOB05WAF4303T5E-TR	430 Kohm	Sold in Tape and Reel of 5,000
MCOB05WAF4703T5E-TC	470 Kohm	Sold by Each
MCOB05WAF4703T5E-TR	470 Kohm	Sold in Tape and Reel of 5,000
MCOB05WAF5103T5E-TC	510 Kohm	Sold by Each
MCOB05WAF5103T5E-TR	510 Kohm	Sold in Tape and Reel of 5,000
MCOB05WAF5603T5E-TC	560 Kohm	Sold by Each
MCOB05WAF5603T5E-TR	560 Kohm	Sold in Tape and Reel of 5,000
MCOB05WAF6203T5E-TC	620 Kohm	Sold by Each
MCOB05WAF6203T5E-TR	620 Kohm	Sold in Tape and Reel of 5,000
MCOB05WAF6803T5E-TC	680 Kohm	Sold by Each
MCOB05WAF6803T5E-TR	680 Kohm	Sold in Tape and Reel of 5,000
MCOB05WAF7503T5E-TC	750 Kohm	Sold by Each
MCOB05WAF7503T5E-TR	750 Kohm	Sold in Tape and Reel of 5,000
MCOB05WAF8203T5E-TC	820 Kohm	Sold by Each
MCOB05WAF8203T5E-TR	820 Kohm	Sold in Tape and Reel of 5,000
MCOB05WAF9103T5E-TC	910 Kohm	Sold by Each
MCOB05WAF9103T5E-TR	910 Kohm	Sold in Tape and Reel of 5,000
MCOB05WAF1004T5E-TC	1 Mohm	Sold by Each
MCOB05WAF1004T5E-TR	1 Mohm	Sold in Tape and Reel of 5,000

ALL RIGHTS RESERVED. NO PORTION OF THIS PUBLICATION, WHETHER IN WHOLE OR IN PART CAN BE REPRODUCED WITHOUT THE EXPRESS WRITTEN CONSENT OF SPC TECHNOLOGY.

SIZE DWG. NO.

A TA-675

ELECTRONIC FILE

TA-675.DWG

REV

A

SPC-F005.DWG

DOC. NO. SPC-F005 * Effective: 7/8/02 * DCP No: 1388

SCALE: NTS

U.Q.M.: Millimeters

SHEET: 5 OF 5