

Subject <b>Low Resistance Value Chip Resistor</b>	Spec. No. 151-RJM-E2W00A
Part No. <b>ERJM1W</b>	10 - 1

**1.Dimension**

***ERJM1WT type***

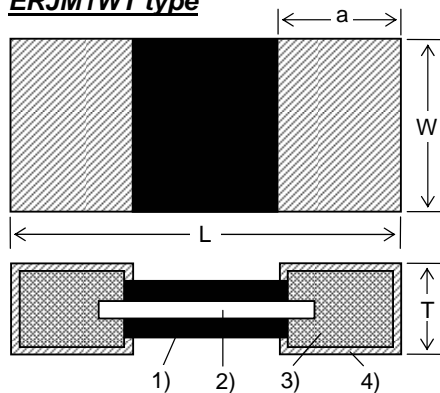

***ERJM1WS type***

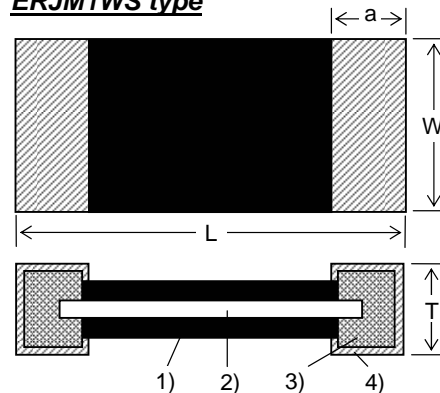

1) Protective Coating	2) Resistive Element	3) Terminal	4) Outer Terminal
Resin	Alloy Metal	Metal	Metal Plating (Sn)

	L	W	T	a
<b>ERJM1WT</b>	6.40+/-0.40 [.252+/- .016]	3.20+/-0.25 [.126+/- .010]	0.80+/-0.30 [.031+/- .012]	2.10+/-0.30 [.083+/- .012]
<b>ERJM1WS</b>	6.40+/-0.25 [.252+/- .010]			1.00+/-0.25 [.039+/- .010]

Unit: mm, [inches]

**2.Power Derating Curve**

*Category Temperature Range (Operating Temperature Range): -55 to +170 deg.C*

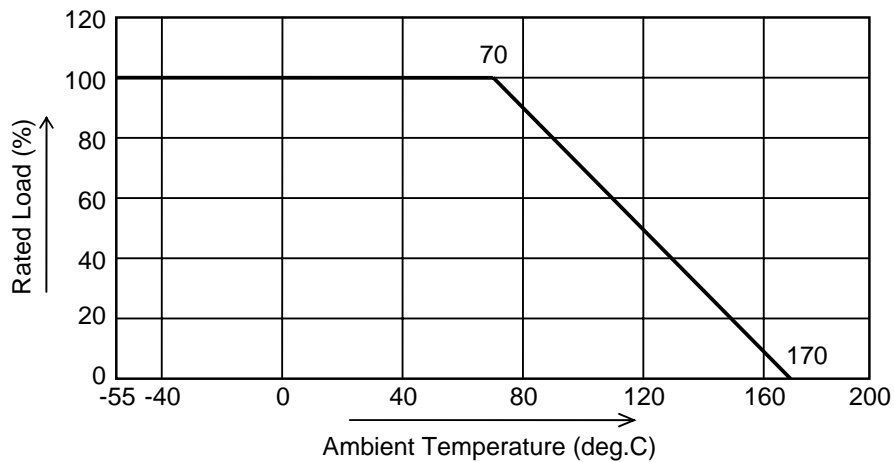

Fig.1

PANASONIC ELECTRONIC DEVICES CO.,LTD.

Subject <b>Low Resistance Value Chip Resistor</b>	Spec. No. 151-RJM-E2W00A
Part No. <b>ERJM1W</b>	10 - 2

### 3.Ratings

Item	Specifications	Explanation
Power Rating	2.0W (70deg.C)	When you use one at ambient temperature over 70deg.C, the load power shall be reduced as shown in Fig.1.
Rated Continuous Working Voltage (RCWV)	The rated voltage at each resistance shall be calculated from the equation below, $E = \sqrt{P \times R}$ E: RCWV(V), P: Rated Power(W), R: Resistance Value(Ω)	
Resistance Tolerance	F: +/-1%, J: +/-5%	
Resistance Range (Standard Resistance Value)	<b>ERJM1WT type:</b> 4mΩ (4mΩ) <b>ERJM1WS type:</b> 5m to 10mΩ (5, 6, 7, 10mΩ)	

### 4. Explanation of Part Number

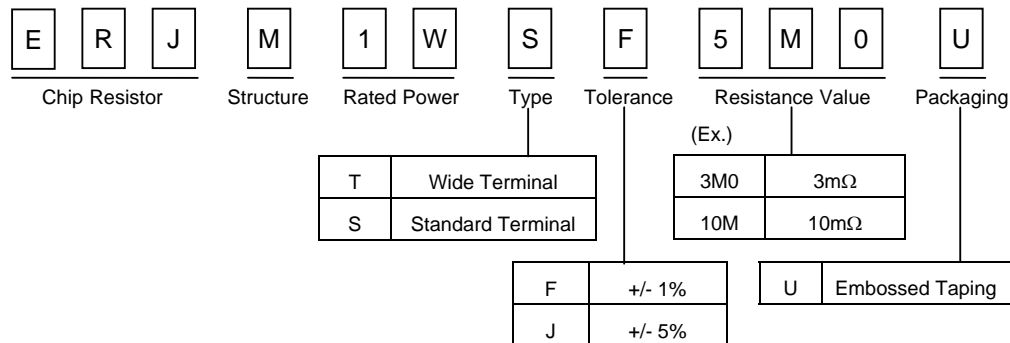

### 5. Appearance and Construction

Item	Specifications and Explanation
Appearance and Construction	<ol style="list-style-type: none"> <li>The surface of resistor is covered with protective coating and hard to fade, then don't have unevenness, flaw pinhole and discoloration.</li> <li>The surface of terminal is covered by the plating. And the plating is hard to fade, then don't have unevenness, flaw, pinhole and discoloration.</li> <li>The terminal is connected with resistive plate certainly.</li> </ol>

PANASONIC ELECTRONIC DEVICES CO.,LTD.

Subject <b>Low Resistance Value Chip Resistor</b>	Spec. No. 151-RJM-E2W00A
Part No. <b>ERJM1W</b>	10 - 3

As far as there shall not designation especially, the following test and measurement shall be operated under normal temperature(15 to 35deg.C), normal humidity(25 to 75%), normal atmospheric pressure( $8.6 \times 10^4$  to  $1.06 \times 10^5$ Pa).

Resistance value shall be guaranteed as like followings.

<Measuring method: In measuring resistance value, 4 wires must be put on top terminal.>

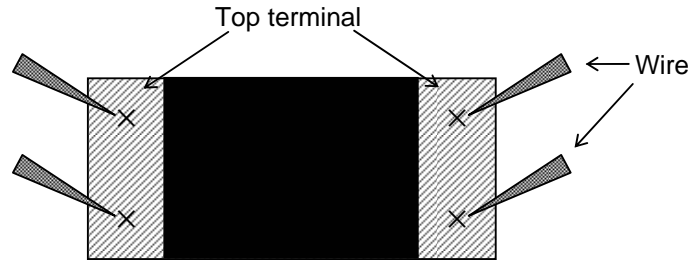

### 6.Electrical Performance Characteristics

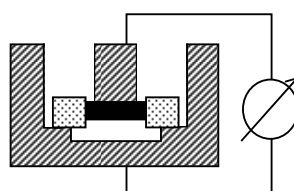
Item	Specifications	Test Methods(Based on JIS - C5201)
DC Resistance	DC Resistance value must be within the specified tolerance.	Measuring current: 1A 20deg.C 65%RH
Temperature Coefficient	<b>ERJM1WT type</b> $\geq 4\text{m}\Omega$ $\pm 75 \times 10^{-6}/\text{deg.C}$	Sequence of temperature: +25deg.C to +125deg.C
	<b>ERJM1WS type</b> $\geq 5\text{m}\Omega$ $\pm 75 \times 10^{-6}/\text{deg.C}$	
Intermittent Overload	$\Delta R = \pm(5\% + 0.5\text{m}\Omega)$	Resistance change after 1,000 cycles (1 second ON, 25 seconds OFF) at 5 W Rated Power.
Dielectric Withstanding	No evidence of flash over, mechanical damage, arcing or insulation breakdown.	AC500V 1 minute
Insulation Resistance	min.1G $\Omega$	 Measuring Voltage :DC500V

PANASONIC ELECTRONIC DEVICES CO.,LTD.

Subject <b>Low Resistance Value Chip Resistor</b>	Spec. No. 151-RJM-E2W00A
Part No. <b>ERJM1W</b>	10 - 4

### 7.Mechanical Performance Characteristics

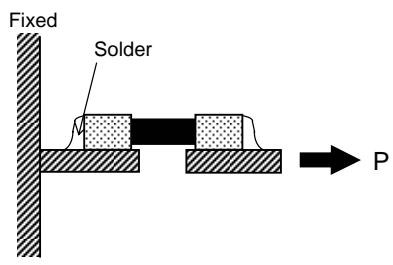
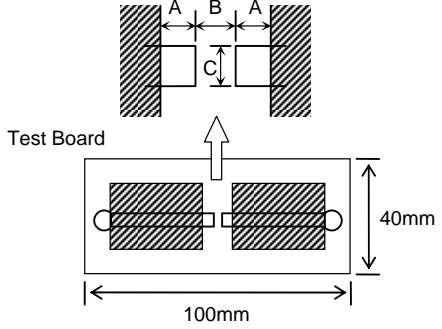
Item	Specifications	Test Methods(Based on JIS-C5201)											
Terminal Strength	min. 4.9N	<p>Copper plate: t = 0.4mm Pull speed :10mm/seconds</p> 											
Bending Strength	Without distinct deformation in appearance	<p>Substrate : Glass Epoxy (t=1.6mm) Span : 90mm Bending Distance : 2mm (10 seconds)</p> <table border="1" data-bbox="860 945 1185 1018"> <thead> <tr> <th></th> <th>A</th> <th>B</th> <th>C</th> </tr> </thead> <tbody> <tr> <td><b>ERJM1WT</b></td> <td>3.1</td> <td>2.2</td> <td rowspan="2">3.4</td> </tr> <tr> <td><b>ERJM1WS</b></td> <td>2.1</td> <td>4.2</td> </tr> </tbody> </table> <p>Unit: mm</p> 		A	B	C	<b>ERJM1WT</b>	3.1	2.2	3.4	<b>ERJM1WS</b>	2.1	4.2
	A	B	C										
<b>ERJM1WT</b>	3.1	2.2	3.4										
<b>ERJM1WS</b>	2.1	4.2											
Solderability	min. 95% coverage	Resistors shall be dipped in the melted solder bath at 230+/-5deg.C for 3+/-0.5 seconds. Next, flux shall be removed from the surface of terminal with clean organic solvent.											
Resistance to Soldering Heat	$\Delta R = +/- (5% + 0.5m\Omega)$	Resistors shall be dipped in the melted solder bath at 270+/-3deg.C for 10+/-1 seconds.											

PANASONIC ELECTRONIC DEVICES CO.,LTD.

Subject <b>Low Resistance Value Chip Resistor</b>	Spec. No. 151-RJM-E2W00A
Part No. <b>ERJM1W</b>	10 - 5

### 8.Environmental Characteristics

Item	Specifications	Test Methods(Based on JIS-C5201)
High Temperature Exposure	$\Delta R = +/- (1\% + 0.5m\Omega)$	Resistors shall be exposed at 125+/-3deg.C for 1000+48/-0 hours.
Temperature Cycling	$\Delta R = +/- (1\% + 0.5m\Omega)$	-55+/-3deg.C 30minutes Normal temp. 30minutes 5 cycles +125+/-3deg.C 30minutes
Humidity (Steady State)	$\Delta R = +/- (1\% + 0.5m\Omega)$	Resistors shall be exposed at 60+/-2deg.C and 90 to 95% relative humidity in a humidity test chamber for 1000+48/-0 hours.
Load Life	$\Delta R = +/- (3\% + 0.5m\Omega)$	Resistors shall be exposed at 70+/-2deg.C for 1000 +48/-0 hours. During this time the rated voltage shall be applied intermittently for 1.5 hours ON,0.5 hours OFF.
Load Life in Humidity	$\Delta R = +/- (3\% + 0.5m\Omega)$	Resistors shall be exposed at 60+/-2deg.C and 90 to 95% relative humidity for 1000+48/-0 hours. During this time the rated voltage shall be applied intermittently for 1.5 hours ON,0.5 hours OFF.

### Used Printed Circuit Board (Unit:mm)

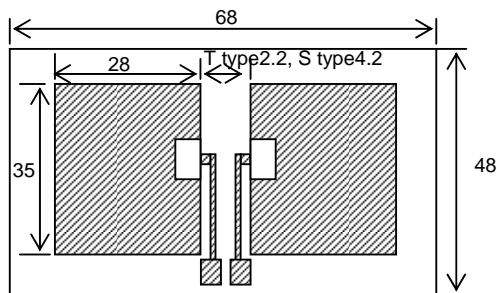

**Material:FR-4 (Test Board t=1.6mm)**  
**Copper Thickness:70 micro meter**

### 9.Resistance Value Marking

Express resistance value on resin side.

	Example
<i>ERJM1WT type</i>	4mΩ:R004
<i>ERJM1WS type</i>	5mΩ:5M0 , 6mΩ:6M0 , 10mΩ:10M

Subject <b>Low Resistance Value Chip Resistor</b>	Spec. No. 151-RJM-E2W00A
Part No. <b>ERJM1W</b>	10 - 6

**10.Recommended Pad Layout**

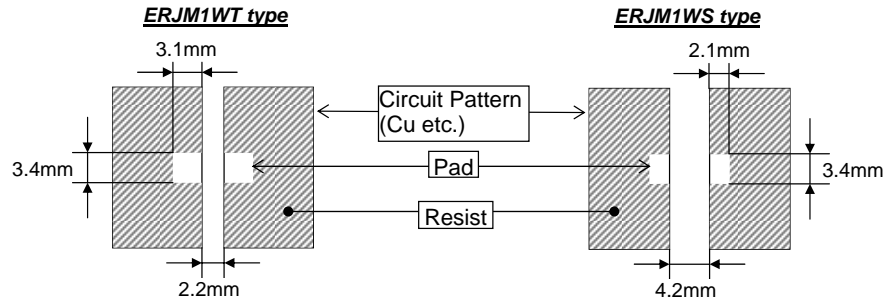

**11.Manufacturing Country**

Indonesia

PANASONIC ELECTRONIC DEVICES CO.,LTD.

Subject <b>Low Resistance Value Chip Resistor</b>	Spec. No. 151-RJM-E2W00A
Part No. <b>ERJM1W</b>	10 - 7

## 12. Precautions in Handling Resistors

### △ Precautions in Handling Resistors

- (1) This specification shows the quality and performance of a unit component. Before adoption, be sure to evaluate and verify the product mounting it in your product.
- (2) We take no responsibility for troubles caused by the product usage that is not specified in this specification.
- (3) In traffic transportation equipment(trains, cars, traffic signal equipment, etc.), medical equipment, aerospace equipment, electric heating appliances, combustion and gas equipment, rotating equipment, disaster and crime preventive equipment, etc. in cases where it is forecast that the failure of this product gives serious damage to the human life and others, use fail-safe design and ensure safety by studying the following items to
  - Ensure safety as the system by setting protective circuits and protective equipment.
  - Ensure safety as the system by setting such redundant circuits as do not cause danger by a single failure.
- (4) When a doubt shall be occurred about safety for this product, be sure to inform us rapidly, operate your technical examination.
- (5) The products in this specification are intended for use in general standard applications for general electronic equipment(AV products, household electric appliances, office equipment, information and communication equipment, etc.); hence, they do not take the use under the following special environments into consideration. Accordingly, the use in the following special environments, and such environmental conditions may affect the performance of the products; prior to use, verify the performance, reliability, etc. thoroughly
  - 1) Use in liquids such as water, oil, chemical, and organic solvent
  - 2) Use under direct sunlight and in outdoor and dusty atmospheres
  - 3) Use in places full of corrosive gases such as sea breeze, Cl<sub>2</sub>, H<sub>2</sub>S, NH<sub>3</sub>, SO<sub>2</sub>, AND NO<sub>x</sub>.
  - 4) Use in environment with large static electricity and strong electromagnetic waves.
  - 5) Where the product is close to a heating component, and where an inflammable such as a polyvinyl chloride wire is arranged close to the product.
  - 6) Where the resistor is sealed and coated with resin, etc.
  - 7) Where water or a water-soluble detergent is used in cleaning free soldering and in flux cleaning after soldering. (Pay particular attention to a water-soluble flux.)
- (6) If transient load (heavy load in a short time) like pulse is expected to be applied, carry out evaluation and confirmation test with resistors actually mounted on your own board. When the load more than rated power is applied under the load condition at steady state, it may impair performance and/or reliability of resistor. Never exceed the rated power.
- (7) The resistor temperature is dependent on the circuit board and pattern to be used, the heat from the neighboring components and ambient temperatures. The resistor temperature may rise up to 170deg.C (upper limit of Category Temperature Range (Operating Temperature Range)) or higher even if you keep the rated power. Prior to use, be sure to evaluate the product mounted on your own board, and then use it under the condition not to damage the board and the neighboring components. When the product shall be used under special condition, be sure to ask us in advance.
- (8) Halogen type (Chlorine type, Bromine type, etc.) or other high-activity flux is not recommended as the residue may affect performance or reliability of resistors.
- (9) When soldering with soldering iron, never touch the body of the chip resistor with a tip of the soldering iron. When using a soldering iron with a tip at high temperature, solder for a time as short as possible. (3 seconds or less up to 350deg.C)
- (10) Avoid physical shock to the resistor and nipping of the resistor with hard tool (a pair of pliers or tweezers) as it may damage protective film or the body of resistor and may affect resistor's performance.
- (11) Keep the rated power and ambient temperature within the specified derating curve.
- (12) Avoid immersion of chip resistor in solvent for a long time. Prior to use, verify the performance.

PANASONIC ELECTRONIC DEVICES CO.,LTD.

Subject <b>Low Resistance Value Chip Resistor</b>	Spec. No. 151-RJM-E2W00A
Part No. <b>ERJM1W</b>	10 - 8

### 13.Storage Method

If the product is stored in the following environments and conditions, the performance and solderability may be badly affected, avoid the storage in the following environments.

- 1) Storage in places full of corrosive gases such as sea breeze, Cl<sub>2</sub>, H<sub>2</sub>S, NH<sub>3</sub>, SO<sub>2</sub> and NO<sub>x</sub>.
- 2) Storage in places exposed to direct sunlight.
- 3) Storage in places outside the temperature range of 5 to 35deg.C and humidity range of 45 to 85%RH.
- 4) Storage over one year after our delivery (This item also applies to the case that the storage method specified in Item 1) - 3) have been followed.)

### 14. Law, Regulation

- 1) This product has not been manufactured with any ozone depleting chemical controlled under the Montreal Protocol.
- 2) This product complies with the RoHS Directive (Restriction of the use of certain Hazardous. Substances in electrical and electronic equipment (DIRECTIVE 2002/95/EC)).
- 3) All the materials used in this part are registered material under the Law Concerning the Examination and Regulation of Manufactures, etc. of Chemical substances.
- 4) All the materials used in this part contain no brominated materials of PBBOs or PBBs as the flame-retardant.
- 5) If you need the notice by letter of "A preliminary judgement on the Laws of Japan foreign exchange and Foreign Trade control", be sure to let us know.

PANASONIC ELECTRONIC DEVICES CO.,LTD.



Subject <b>Low Resistance Value Chip Resistor</b>	Spec. No. 151-RJM-E2W00A
Part No. <b>ERJM1W</b>	10 - 9

### 15. Recommendable reflow soldering profile

Recommendable reflow soldering

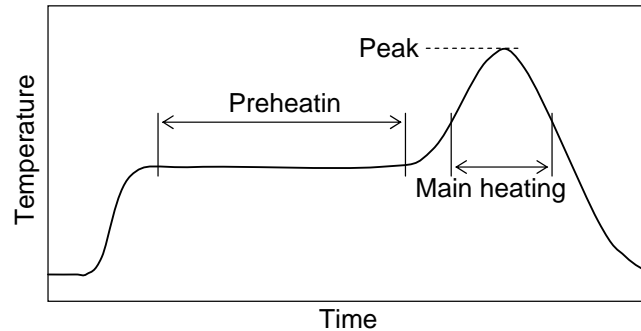

<Lead-free solder>

	Condition	Time
Preheating	150 °C to 180 °C	60 s to 120 s
Main heating	230 °C min.	30 s to 40 s
Peak	260 °C max.	10 s max.

- Please measure temperature of terminals and study solderability every type of boards, before actual use.
- Please inquire of us when you use the different conditions.
- Reflow soldering shall be within two times.

Recommendable flow soldering

	<Lead-free solder>	
	Condition	Time
Preheating	100 °C to 160 °C	60 s to 120 s
Soldering	270 °C max.	10 s max.

Replacement with soldering iron

Note the followings in case of using soldering iron for replacement.

- (1) The tip temperature should be less than 350 °C for the period within 3 s for each terminal.
- (2) The soldering iron tip should not touch the product directly.

PANASONIC ELECTRONIC DEVICES CO.,LTD.

Subject <b>Low Resistance Value Chip Resistor</b>	Spec. No. 151-RJM-E2W00A
Part No. <b>ERJM1W</b>	10 - 10

**Taping**

**1. Application Range**

This specification covers taping spec. of ERJM1W Type.

**2. Physical Dimensions**

2-1 Structure and reel dimensions shall be as shown in the figure below.

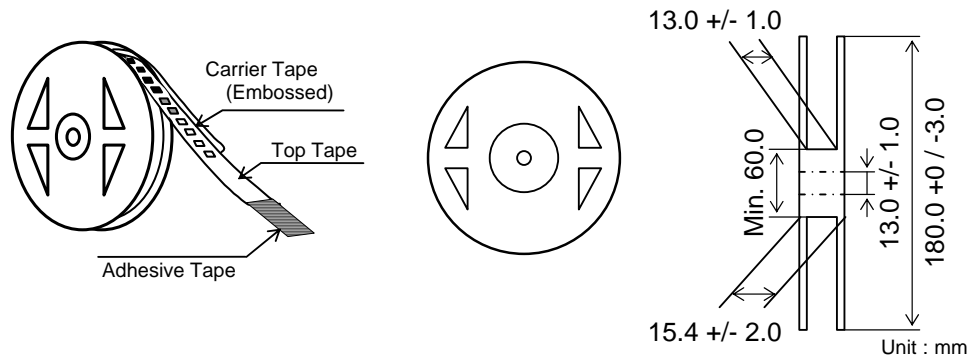

**2-2 Carrier Tape Dimensions**

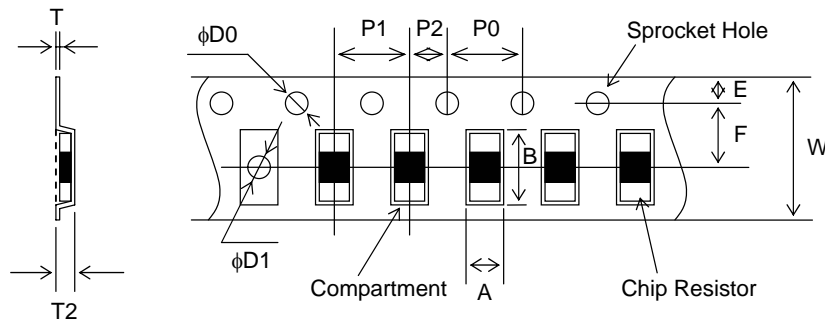

A	B	W	F	E	P1
3.60+/-0.20 [.141+/- .008]	6.90+/-0.20 [.272+/- .008]	12.0+/-0.30 [.472+/- .012]	5.50+/-0.05 [.217+/- .002]	1.75+/-0.10 [.069+/- .004]	4.00+/-0.10 [.157+/- .004]

P2	P0	φD0	φD1	T	T2
2.00+/-0.05 [.079+/- .002]	4.00+/-0.10 [.157+/- .004]	1.50+0.10/-0 [.059+0.04/-0]	Min. 1.50 [Min. .059]	Max. 0.40 [Max. .016]	1.60+/-0.10 [.063+/- .004]

Unit: mm, [inches]

PANASONIC ELECTRONIC DEVICES CO.,LTD.

Subject <b>Low Resistance Value Chip Resistor</b>	Spec. No. 151-RJM-E2W00A
Part No. <b>ERJM1W</b>	10 - 11

### 3. Specifications

#### 3-1 Specifications of Taping

- When the test shall be operated with the below conditions, the peel strength shall be 0.098N to 0.686N and the tape shall not have flash and tear after peeling.

<Test Method>

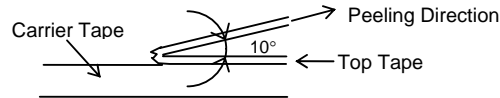

- Minimum Bending Radius

When the carrier tape shall be bent to Minimum Bending Radius (15mm), there shall be no deflection of chip and no break of the carrier tape. However the test shall be done for 1 time.

- Resistance to climate

When resistors shall be exposed at 60deg.C, 90 to 95 %RH for 120 hours, there shall be no deflection of chip and no break of carrier tape. When the top tape shall be peeled, it shall not have flash and tear.

#### 3-2 Quantity in Reel : 3000 pcs./reel

#### 3-3 Taping Condition

- Chip resistors shall not be sticking to top tape and bottom tape.
- Chip resistors shall be easy to take out from carrier tape.
- Compartment and sprocket hole shall not have flash and break.

### 4. Outer Packaging

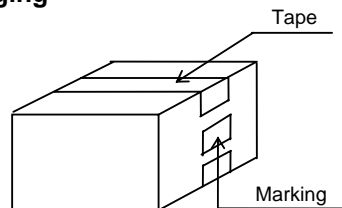

- When reels shall not reach Max. quantity, the remaining empty space shall be buried with buffer material.
- When the quantity shall be few, alternative packaging methods may be used. No problem must occur during the exportation of the product.

### 5. Marking

- Side of Reel(Marking shall be on one side.)
  - Part Name('Fixed metal plate flat chip resistor' following part name on invoice)
  - Part Number
  - Quantity
  - Lot Number
  - Maker Name
  - Manufacturing Country
- Packaging Box
  - Part Number
  - Quantity
  - Maker Name

PANASONIC ELECTRONIC DEVICES CO.,LTD.