

Bourns®

Trimpot® Product Catalog



Reliable Electronic Solutions

Table of Contents

Introduction	4
Custom Solutions	
Fuel Card Applications.....	8
3-D MID Devices.....	11
Thick-Film Cermet Devices.....	12
Polymer Thick-Film (PTF) Devices.....	13
Trimmer Special Offerings.....	14
Linear Motion Potentiometer Special Offerings.....	15
Modular Contact Special Offerings.....	15
Switch Special Offerings.....	15
Selection Guides	
RoHS Compliant Selection Guide.....	17
SMT Selection Guide	18
Commercial/Industrial Selection Guide	19
Consumer/Open Frame Selection Guide.....	20
Application Specific Selection Guide.....	20
Military Product Selection Guide.....	20
Optional Products.....	21
Trimmer Data Sheets	
3005.....	24
3006.....	25
3009.....	26
3057.....	27
3059.....	28
3214.....	29
3223.....	31
3224.....	32
3250.....	34
3252.....	35
3260.....	36
3262.....	37
3266.....	38
3269.....	40
3290.....	42
3292.....	43
3296.....	44
3296-LC2.....	48
3296-OT1.....	49
3299.....	50
3302.....	52
3303.....	53
3306.....	55

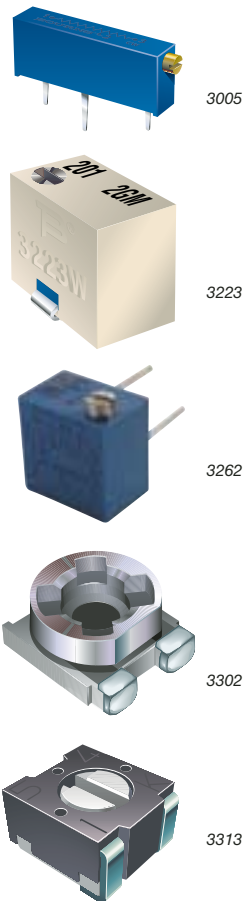

Table of Contents

Trimmer Data Sheets (continued)

3309.....	53
3313.....	55
3314.....	57
3318PSGB	62
3318FK	66
3319.....	68
3329.....	70
3339.....	72
3342.....	73
3345.....	75
3352.....	76
3360.....	77
3361.....	79
3362.....	81
3364.....	83
3386.....	85
3386-HV2	88
3386-HV3	88
3386-OT1.....	89
TC03	90
TC22	91
TC33	92
TC73	93
TC86.....	94
TC89.....	96

Mil-Spec Numbering System – Defined	98
---	----

Military Trimmer Data Sheets

RT12	103
RT/RTR22.....	104
RT/RTR24.....	105
RT26	106
RJ12	107
RJ22	108
RJ/RJR24	109
RJ/RJR26	110
RJ/RJR50.....	111

Linear Motion Potentiometers

3046	114
3048	115

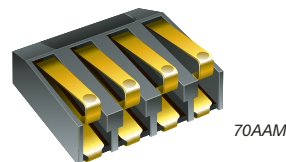
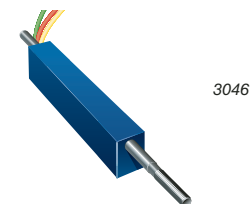
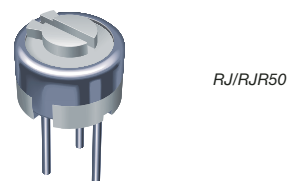
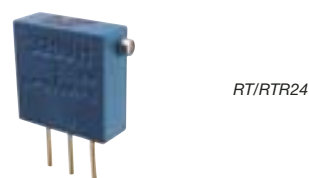
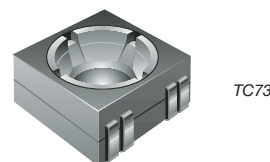
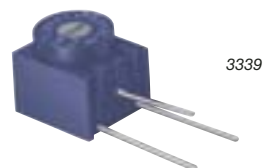
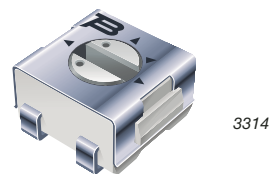

Table of Contents

Modular Contacts

70AAF	118
70AAM.....	119
70ADF	121
70ADM.....	122

Switches

7813	124
7814	126
7829	128
7914	129
SDHH.....	131
SDM.....	133
SDT	134
SDTM.....	137
SND	139
ST(H,M,J)W	141
STJN-4.....	143
STJN-5.....	144
STSM	145

Technical Guides

Applications/Processing Guide – Standard and Lead Free	148
Lead Free Solder Reflow Profile	155
Standard Soldering and Cleaning Process	156
Factory Installed Panel Mount	160
Customer Installed Panel Mount	162
Hardware for Special Mounting Applications	164
H-90/H-91/H-92-1 Adjustment Tools	165
Bourns® Trimpot® Design Kits	166

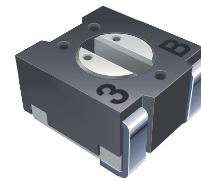

7813

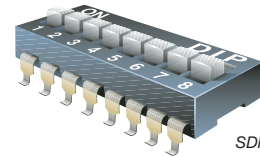

SDM

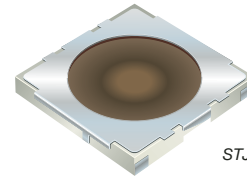

STJN-5



More than fifty-seven years ago co-founders Marlan and Rosemary Bourns set up shop in their tiny 384 square-foot garage in Altadena, California. Their idea to provide a method of accurately determining an aircraft's vertical position solved a crucial problem for pilots. The invention of the first miniature linear motion and vane position potentiometers propelled their tiny business into a global corporation, manufacturing a range of products that impact almost every aspect of today's electronics industry.

From its earliest days, Bourns established a benchmark for quality, value, and innovation. In 1952, Bourns patented the world's first trimming potentiometer, trademarked Trimpot®. Bourns dedication to excellence ensures continuous improvement of its products and services to satisfy customer requirements on a global basis.

The company, with worldwide headquarters in Riverside, California and nine other facilities around the world has continued growing through acquisitions and start-ups. Product lines now include precision potentiometers, panel controls, encoders, resistor/capacitor networks, chip resistors/arrays, inductors, transformers, resettable fuses, thyristor-based overvoltage protectors, line feed resistors, gas discharge tubes, telephone station protectors, 5-pin protectors, industrial signal, irrigation and petroleum protectors, CATV coax protectors, signal data protectors, indoor and outdoor POTS splitters, network interface devices, and integrated circuits.

Introduction

The Bourns Mission

Our goal is to satisfy customers on a global basis while achieving sound growth with technological products of innovative design, superior quality and exceptional value. We commit ourselves to excellence, to the continuous improvement of our people, technologies, systems, products and services, to industry leadership and to the highest level of integrity.

Bourns Corporate

Bourns, Inc. has been providing reliable and innovative solutions to the electronics industry for over 50 years. With manufacturing facilities and customer support teams located throughout the world, Bourns is uniquely positioned to serve the industrial, automotive, telecommunications, audio/visual, aerospace and other electronic industries. Most importantly, Bourns is firmly committed to quality, service, and innovation.

World-Class Manufacturing

Bourns® Trimpot® Division has manufacturing facilities in Logan Utah, Tijuana Mexico, Heredia Costa Rica, Cork Ireland, Taipei Taiwan and Xiamen China. All of our facilities are QS9000 accredited.

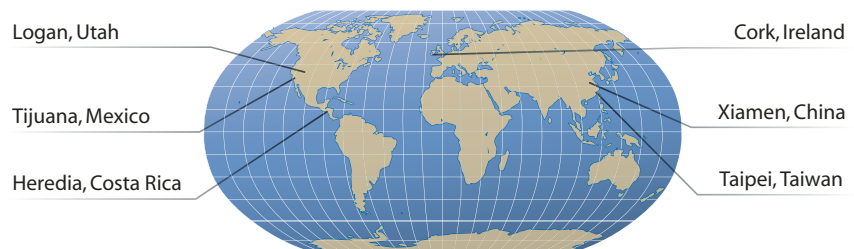



Commitment to Quality

Bourns commitment to quality is embedded in every discipline of the corporation. Customer satisfaction is essential to every Bourns employee. All team members receive training in their specific area of responsibility to ensure the highest level of performance.

Technical Support

Trained sales representatives, account managers and distributor sales engineers are located conveniently throughout the U.S. and around the world. Our Application Engineers (AEs) are also strategically located to assist with technical support and to provide an interface between customer inquiries and our production facility. Our technical support team can provide you with solutions appropriately selected to satisfy your requirements for performance, cost and availability.

Customer Service

Bourns distributor network is the most extensive in the industry. Our distributors provide fast, localized delivery and service in all three geospheres. With 100% on-time delivery and world-class service as core business objectives, we ensure direct support for customers in all countries and market segments.

From innovative designs to on-time delivery, make Bourns® Trimpot® your first choice for reliable and cost-effective trimmers, switches, linear motion potentiometers, modular contacts and fuel cards.



Custom Solutions



Fuel Cards

Many of the world's leading manufacturers have long known Bourns as a company they can trust to deliver quality electronic components on-time and within target costs. At Bourns, we understand that automotive manufacturers need complete solutions, from simple substrates to complete substrate and cable assemblies. To achieve an optimum blend of price and quality, we are structured to be one of the world's most vertically integrated suppliers. Bourns® Trimpot® Division offers numerous solutions for fuel level sensing requirements.

Fuel Level Sender

The fuel level in automotive applications is typically measured by a float and lever arm assembly that operates a variable resistor mechanism. In many cases, this assembly (known as a fuel sender or fuel level sender) is mounted in the fuel tank and integrated into the fuel delivery module. This module removes fuel from the tank and delivers pressurized fuel to the power train.

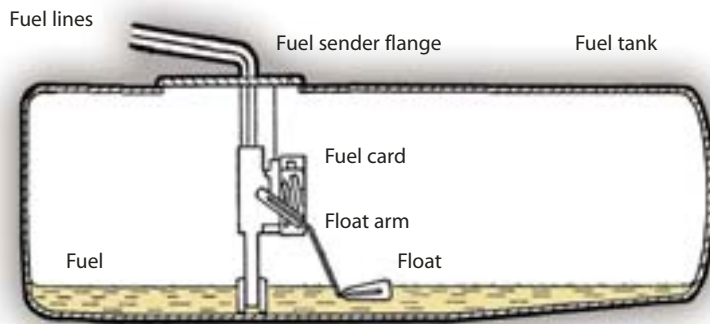

Figure 2: Fuel level sender mounted in fuel tank

Fuel Level Sender Design & Construction

The variable resistor mechanism is comprised of a wiper and a resistor element printed on a ceramic substrate. The resistor element (also known as a fuel card) is mounted close to the pivot point of the float arm, which is attached to the wiper. As the float rises and falls with the fuel level, the wiper moves in a rotary motion across the tracks on the resistor element, translating the float position into a resistance value. This is converted into a voltage or current signal driving the indication system in the dashboard. Less common are linear type fuel level senders where a float moves within a tube, translating the fuel level into a linear wiper movement. This type of fuel level sender is mainly used in space-constrained tanks, as in motorcycles and scooters.

Most car models have custom designed fuel tanks, where the tank is molded to fit around other components and body frames. There is an increasing trend to use a more complex blow-molded plastic tank versus the traditional steel tank. On rear wheel drive and four wheel drive vehicles, a saddle tank is often used, where the two halves of the fuel tank straddle the rear drive shaft. These complex fuel tank geometries require specific fuel card resistor profiles so that the translation of the

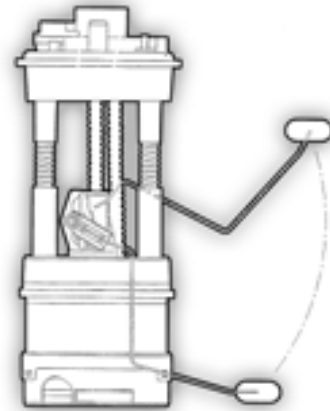

Figure 1: Fuel delivery module



Figure 3: Bourns fuel level sender

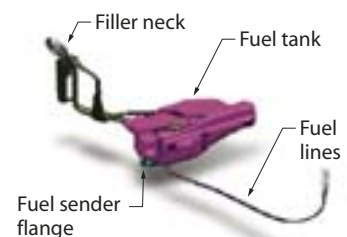

Figure 4: Overview of automotive fuel storage & delivery system

float height gives the appropriate fuel volume signal to the fuel gauge. For this reason, a custom fuel card is generally designed for each fuel tank model.

The first fuel senders were wirewound construction. However, in many instances these units suffered from wire wear and breakages. The resistance profile of the wirewound fuel sender also changed as the wire wore at different rates and positions of the float arm. These problems were overcome with the introduction of the thick-film fuel card. A variable resistor is achieved by tapping the resistor traces with segmented conductor tracks creating a step-function output as shown in Figure 6. If the wiper contact were to run directly on the cermet resistor, as in a potentiometer, the required product life specification of at least 1 million wet cycles would not be achieved. A tight resistance tolerance of each partial resistor is achieved by laser trimming.

As the fuel card (resistor element) is immersed in fuel, its chemical resistance is of great importance. The introduction of low-sulphur fuels for environmental reasons has placed additional demands on conductor metallurgies.

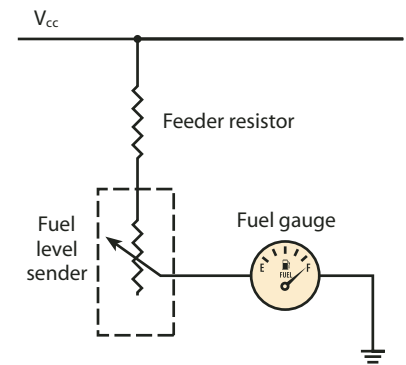

Figure 5: Typical fuel level indication circuit

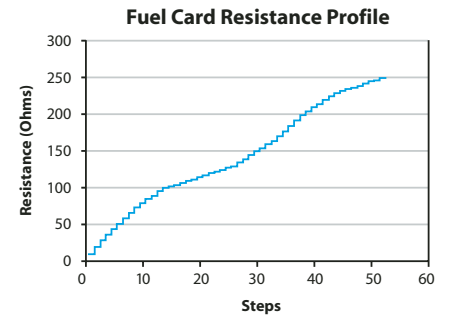

Figure 6: Example of step-function output

Typical Fuel Card Designs

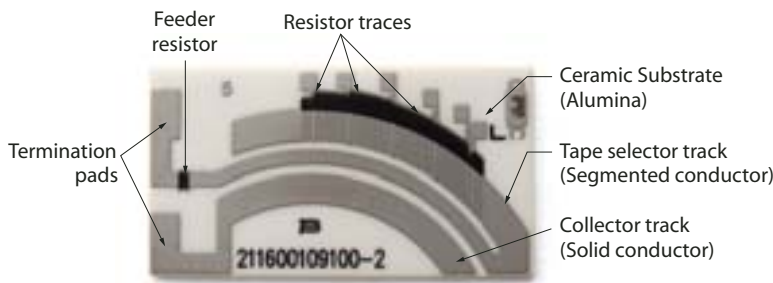

Figure 7: Fuel card design overview (Dual track design)



Figure 8: Dual track design



Figure 9: Single track design



Figure 10: Linear track design

Specifications are typical and dependent on the manufacturing method, materials, size and shape of the part.

Trends in the fuel level sender market ▶

Trends in the fuel level sender market

- Increased fuel sender accuracy and resolution requirements due to increased integration of dashboard electronics and driver information systems.
- ☑ Bourns is currently shipping fuel cards with up to 100 discrete resistance steps.
- Increased chemical resistance: The major driver for increased chemical resistance is driven by the introduction of low-sulphur fuels, particularly in the U.S. market. These fuels may contain reactive sulphur compounds, which react with traditional palladium silver conductor inks.
- ☑ Bourns offers a range of materials to meet this requirement, from increased palladium content inks to “silver free” gold inks.
- Increased product integration: An increasing number of customers are now requesting higher levels of product integration.
- ☑ Bourns offers fuel cards with leads attached, tinned pads and wiper contacts.

The Bourns Competitive Advantage

- Dedicated fuel card design and sample team for rapid sample turnaround
- Full fuel sender design capability
- Active fuel sender R&D program with several patents issued or pending
- Extensive corporate material science expertise and R&D facilities
- Internally developed, state of the art, thick-film print capability with outstanding print registration and in-line ink thickness measurement
- Competitive pricing for best cost/life benefit
- High volume manufacturing
- Manufacturing location QS9000 certified and TS16949 planned for Cork, Ireland in 2005
- Superior product quality through 100% end-of-line dynamic testing
- Extensive production experience in gold fuel cards for low-sulphur fuel applications
- Superior, vision assisted, laser trim capability

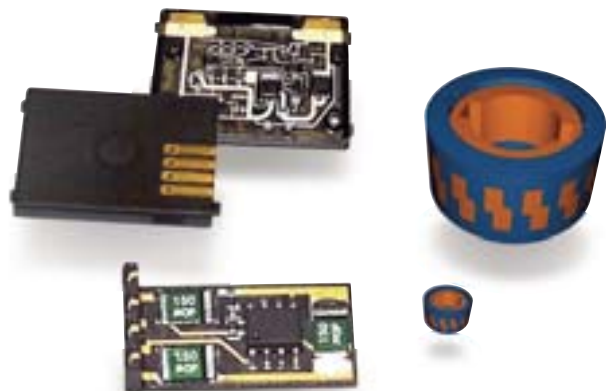

3-D MID Devices

Bourns is also applying our thick-film printing capabilities to manufacture 3-D Molded Interconnect Devices (MIDs), which integrate the housing with the circuit board. Two advantages are board size and reduction of piece parts. Applications include high frequency connectors, security housings, antennas and EMC screening.

Electrical Characteristics

Current Handling	3 A, track width 1 mm
ESD (Contact).....	±8 kV, 10 times
ESD (Air).....	±15 kV, 10 times
Conductivity	1.6 μΩ-cm, 1 oz copper
RF Capability	up to 10 GHz

Environmental Characteristics

Temperature Cycling	-40 °C/+100 °C
Air Temperature Low	-25 °C; 24 hrs
Air Temperature High.....	+70 °C; 24 hrs
Humidity.....	+85 °C; 85 % RH; 96 hrs
Thermal Shock	-40 °C to +85 °C; 24 cycles

Physical Characteristics

Vibration Shock	30 G
Wear Resistance.....	20,000 cycles, 0.8 N
Peel Test	20 N
Pull Test	10 kN
Shear Test	40 N (0805; SOD123)
Solderability.....	≥ 95 %
Lithium Salt Test.....	Pass
Halt Test.....	Pass
Wirebondable	Yes
Weldable	Yes
Recyclable.....	Yes

Physical Characteristics

Min. Dimensions	≥ 5 mm
Wall Thickness	≥ 0.5 mm
Track Width.....	≥ 70 μm
Plating Composition.....	Cu, Ni, Sn/Pb & Au
Plating Thickness	2 to 50 μm
3-D Shapes	Yes

Specifications are typical and dependent on the manufacturing method, materials, size and shape of the part.

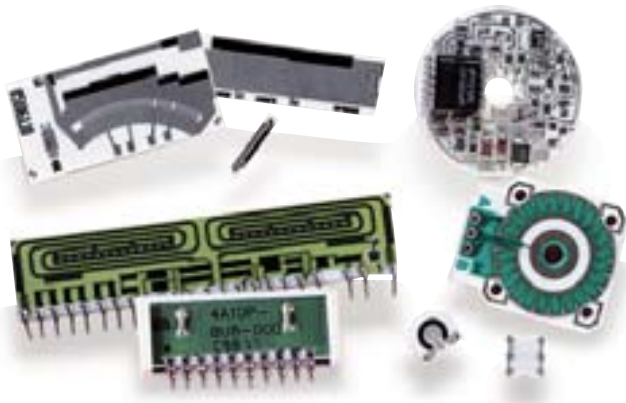

Thick-Film (Cermet) Devices

Using our thick-film printing expertise, Bourns® Trimpot® Division has many possible applications such as ceramic heaters for medical, industrial, military and commercial applications.

Features

- High temperature operation
- Improved high frequency performance
- Excellent thermal conductivity
- Reduced piece part and size
- Design flexibility
- Custom specific
- High life cycles
- Reduced time to market for new ideas

Electrical Characteristics

Resistive

Standard Resistance Range	10 Ω to 1 MΩ
Resistance Tolerance (Untrimmed)	±10 %
Resistance Tolerance (Trimmed).....	±0.5 %
Independent Linearity	Down to ±0.5 %
Resolution	Infinite
Electrical Travel.....	Per Requirement
Ratio Matching.....	0.1 %

Conductive

Resistivity	Down to 3 μΩ-cm
-------------------	-----------------

Environmental Characteristics

Power Rating.....	0.5 W
Temperature Range	-55 °C to +150 °C
TCR	± 100 ppm/K
Humidity (MIL-STD-202 Method 106)	± 1 % TRS
Vibration (30 G).....	± 1 % TRS
Shock (100 G).....	± 1 % TRS
Load Life (1,000 h).....	± 2 % TRS
Rotational Life.....	Up to 1,000,000 cycles
Thermal Shock (-55 °C/+150 °C)	± 1 % TRS

Physical Characteristics

Substrate Materials	Alumina Aluminum Nitride
---------------------------	-----------------------------

Ink Materials.....	Resistive Dielectric Conductive (Au, Ag, AgPd)
--------------------	--

Conductor Line Width	0.157 mm (0.0062 ")
----------------------------	---------------------

Conductor Line Thickness	min. 8 μm (0.3 μ")
--------------------------------	--------------------

Conductor Line Spacing	0.127 mm (0.005 ")
------------------------------	--------------------

Track Adhesion	1.58 N/mm
----------------------	-----------

Solder Acceptance.....	99 % coverage
------------------------	---------------

Solder Leach Resistance.....	5 cycles
------------------------------	----------

Additional Capabilities

- Placement of Add-On Components
- RF Design
- Through-Hole Print
- Multi-Layer Print
- Double-Sided Print
- Custom Tapers
- Plating Operation
- Solder Paste Deposition

Specifications are typical and dependent on the manufacturing method, materials, size and shape of the part.

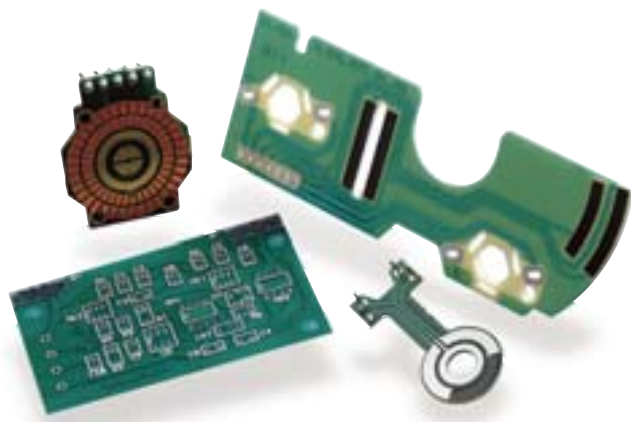

Polymer Thick-Film (PTF) Devices

Features

- Utilization of alternative substrate materials
- Solution for numerous position sensing applications
- Reduced piece part and size
- Design flexibility
- Custom specific
- High life cycles
- Reduced time to market for new ideas

Electrical Characteristics

Resistive

Standard Resistance Range	1 kΩ to 1 MΩ
Resistance Tolerance (Untrimmed)	± 20 %
Resistance Tolerance (Trimmed).....	± 1 %
Independent Linearity	Down to ± 2 %
Contact Resistance Variation	1 Ω or 1%
Resolution	Infinite
Dielectric Strength	
Sea Level	1,500 vac
70,000 feet.....	500 vac
Electrical Travel	Per requirement

Conductive

Resistivity.....	10 μΩ-cm
------------------	----------

Environmental Characteristics

Power Rating.....	0.2 W
Temperature Range	-10 °C to +125 °C
Humidity (50 % RH)	±10 % TRS
Vibration (15 G)	±2 % max. TRS ±5 % max. VRS
Shock (30 G)	±2 % max. TRS ±5 % max. VRS
Load Life (1,000 h).....	±10 % TRS
Rotational Life	20,000 cycles
Thermal Shock (-40 °C/+120 °C)	±2 % TRS

Physical Characteristics

Substrate Materials	
.....	PCB (rigid/flexible) Plastics
Ink Materials.....Resistive Dielectric Conductive (Au, Ag, AgPd)	
Track Adhesion	1.58 N/mm
Solder Acceptance	90 % coverage
Solder Leach Resistance.....	5 cycles

Additional Capabilities

- Placement of Add-On Components
- Through-Hole Print
- Multi-Layer Print
- Double-Sided Print
- Custom Tapers
- Plating Operation
- Solder Paste Deposition

Specifications are typical and dependent on the manufacturing method, materials, size and shape of the part.

Trimmer Special Offerings

Bourns® Trimpot® Division offers the widest array of trimmers in the industry. Our product offering includes surface mount and through-hole sealed and open frame trimmers. Bourns is also the only trimmer manufacturer which offers military trimmers and product qualified to military drawings. Consult Bourns technical support for more detailed information.

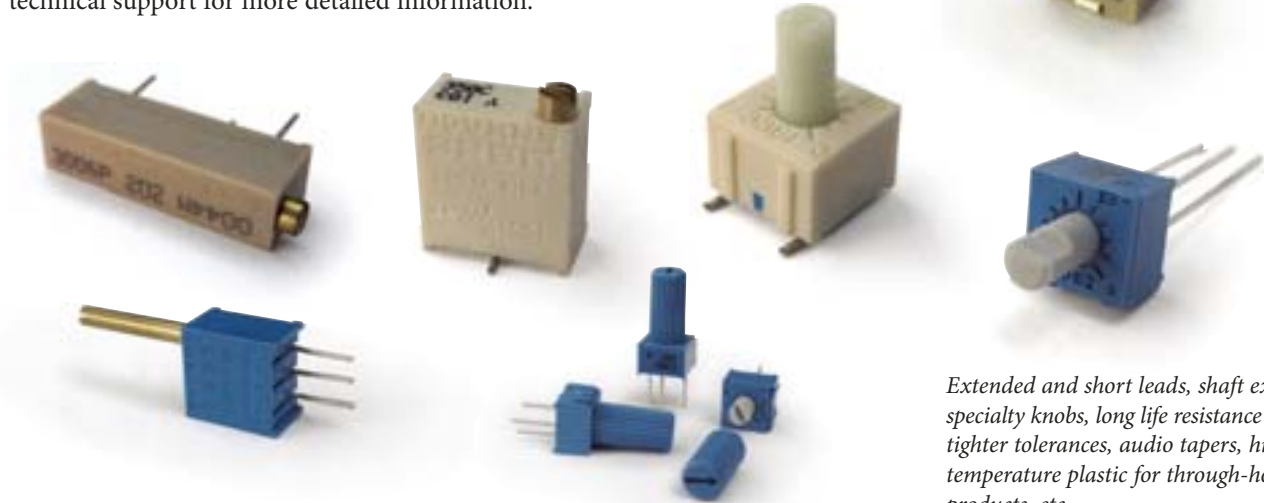

Extended and short leads, shaft extensions, specialty knobs, long life resistance elements, tighter tolerances, audio tapers, high temperature plastic for through-hole products, etc.

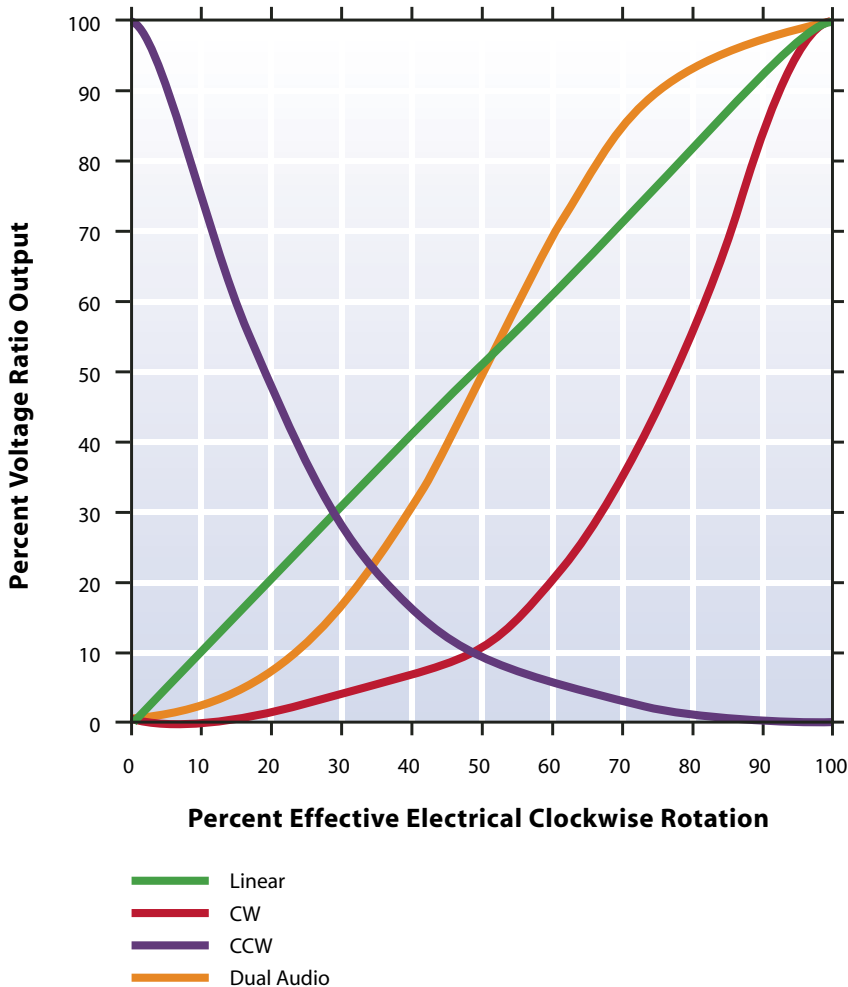

A chart of the audio tapers and the options is shown to display the different tapers.

Linear Motion Potentiometer Special Offerings

In addition to our standard linear motion potentiometer offering, Bourns® Trimpot® Division offers custom shaft lengths, threads and hard pins.



Modular Contact Special Offerings

Modular contacts are available with special plating options, adaptors to raise the contact height, lead lengths and forming on through-hole modular contacts. This does not limit the special offering; consult Bourns technical support for more detailed information on the feasibility of a special modular contact.



Switch Special Offerings

Bourns® Trimpot® Division specializes in miniature switches, special switch configurations and markings. Consult with technical support personnel for availability.

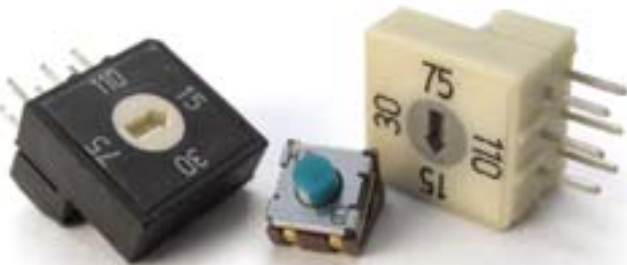

Selection Guides

Selections

Selections Guide Selections Guide Selections Guide s

RoHS Compliant Selection Guide

Cermet/Carbon Models listed below are only available with lead free terminals.

Model	RoHS Compliant	Plating
3214	Yes	100 % Sn
3223	Yes	100 % Sn
3224	Yes	100 % Sn
3302	Yes	100 % Sn
3303	Yes	100 % Sn
3306	Yes	100 % Sn
3309	Yes	100 % Sn
3313	Yes	100 % Sn
3314	Yes	100 % Sn
3318PSGB	Yes	100 % Sn
3318FK	Yes	100 % Sn
3319	Yes	100 % Sn
3342	Yes	100 % Sn
3364	Yes	100 % Sn
TC03	Yes	100 % Sn
TC22	Yes	100 % Sn
TC33	Yes	100 % Sn
TC73	Yes	100 % Sn
TC86	Yes	100 % Sn
TC89	Yes	100 % Sn

Cermet Models listed below are only available with tin-lead terminals. Military trimmers are governed by DSCC.

Model	RoHS Compliant	Plating
RJ12	No	90/10 Sn/Pb
RJ22	No	90/10 Sn/Pb
RJ24	No	90/10 Sn/Pb
RJR24	No	90/10 Sn/Pb
RJ26	No	90/10 Sn/Pb
RJR26	No	90/10 Sn/Pb
RJ50	No	90/10 Sn/Pb
RJR50	No	90/10 Sn/Pb

Wirewound Models listed below are only available with lead free terminals. Military trimmers are governed by DSCC.

Model	RoHS Compliant	Plating
RT12	Yes	100 % Au
RT22	Yes	100 % Au
RTR22	Yes	100 % Au
RT24	Yes	100 % Au
RTR24	Yes	100 % Au
RT26	Yes	100 % Au

Cermet Models listed below will be offered in both lead free and tin-lead terminals. Tin-lead terminal part numbers (below left) will not change. Lead free product (below right) requires an LF suffix.

Tin-lead part numbers

Model	RoHS Compliant	Plating
20	No	90/10 Sn/Pb
3006	No	90/10 Sn/Pb
3009	No	90/10 Sn/Pb
3059	No	90/10 Sn/Pb
3082	No	90/10 Sn/Pb
3252	No	90/10 Sn/Pb
3262	No	90/10 Sn/Pb
3266	No	90/10 Sn/Pb
3269	No	90/10 Sn/Pb
3292	No	90/10 Sn/Pb
3296	No	90/10 Sn/Pb
3299	No	90/10 Sn/Pb
3329	No	90/10 Sn/Pb
3339	No	90/10 Sn/Pb
3352	No	90/10 Sn/Pb
3360	No	90/10 Sn/Pb
3361	No	90/10 Sn/Pb
3362	No	90/10 Sn/Pb
3386	No	90/10 Sn/Pb

Lead free part numbers

Model	RoHS Compliant	Plating
20(LF)	Yes	100 % Sn
3006(LF)	Yes	100 % Sn
3009(LF)	Yes	100 % Sn
3059(LF)	Yes	100 % Sn
3082(LF)	Yes	100 % Sn
3252(LF)	Yes	100 % Sn
3262(LF)	Yes	100 % Sn
3266(LF)	Yes	100 % Sn
3269(LF)	Yes	100 % Sn
3292(LF)	Yes	100 % Sn
3296(LF)	Yes	100 % Sn
3299(LF)	Yes	100 % Sn
3329(LF)	Yes	100 % Sn
3339(LF)	Yes	100 % Sn
3352(LF)	Yes	100 % Sn
3360(LF)	Yes	100 % Sn
3361(LF)	Yes	100 % Sn
3362(LF)	Yes	100 % Sn
3386(LF)	Yes	100 % Sn

Wirewound Models listed below are only available with lead free terminals.

Model	RoHS Compliant	Plating
3005	Yes	100 % Au
3057	Yes	100 % Au
3250	Yes	100 % Au
3260	Yes	100 % Au
3290	Yes	100 % Au
3345	Yes	100 % Au

Modular Contacts

Model	RoHS Compliant	Plating
70AAF	Yes	100 % Sn
70AAM	Yes	100 % Sn
70ADF	Yes	100 % Sn
70ADM	Yes	100 % Sn

Switches

Model	RoHS Compliant	Plating
7813	Yes	100 % Sn
7814	Yes	100 % Sn
7829	Yes	100 % Sn
7914	Yes	100 % Sn
SDHH	Yes	100 % Sn
SDM	Yes	100 % Sn
SDT	Yes	100 % Sn
SDTM	Yes	100 % Sn
SND	Yes	100 % Sn
STW	Yes	100 % Sn
STJN-4	Yes	100 % Sn
STJN-5	Yes	100 % Sn
STSM	Yes	100 % Sn

Linear Motion Potentiometers

Model	RoHS Compliant	Plating
3046	Yes	Cu wire
3048	Yes	Cu wire

SMT Trimmers

Model Number	Element Technology		Number of Turns		Sealed/Opened		Size				Packaging Options	Adjust	Page No.
	Cermet	Carbon	Single	Multi	Sealed	Opened	2 mm	3 mm	4 mm	1/4 "	See Note 1	See Note 2	
3214	◆			◆	◆				◆		E, G	T, S	29
3223	◆			◆	◆			◆			E	T	31
3224	◆			◆	◆				◆		E, G	T, S	32
3269	◆			◆	◆					◆	G, T	T, S	40
3302	◆		◆				◆				E	T	49
3303	◆		◆					◆			E	T, B	50
3313	◆		◆		◆			◆			E	T, S	55
3314	◆		◆		◆				◆		E, G, T	T, S, B	57
3342	◆		◆		◆		◆				E	T	73
3361	◆		◆		◆					◆	G	T, S	79
3364	◆		◆						◆		E	T	83
TC03	◆		◆					◆			E	T	90
TC22	◆		◆				◆				E	T	91
TC33	◆		◆					◆			E	T	92
TC73		◆	◆					◆			E	T	93

Note 1: Standard packaging; some options may require alternate packaging. Consult factory.

E = 7" Reel, G = 13" Reel, T = Tubes

Note 2: T = Top Adjust, S = Side Adjust, B = Bottom Adjust

See page 155 for processing information on lead free surface mount trimmers.

Commercial Trimmers

Model Number	Element Technology		Number of Turns		Size						Packaging Options	Adjust	Page No.	
	Cermet	W/W	Single	Multi	1/4 "	5/16 "	3/8 "	1/2 "	20 mm	3/4 "	1-1/4 "	See Note 1		See Note 2
20	◆			◆					◆			T	S	22
3005		◆		◆						◆		T	S	24
3006	◆			◆						◆		T	S	25
3009	◆			◆						◆		T, B	S	26
3057		◆		◆							◆	T, B	S	27
3059	◆			◆							◆	T, B	S	28
3082	◆			◆				◆				T	S	22
3250		◆		◆				◆				T, B	T, S	34
3252	◆			◆				◆				T, B	T, S	35
3260		◆		◆	◆							T	T, S	36
3262	◆			◆	◆							T	T, S	37
3266	◆			◆	◆							T, R	T, S	38
3290		◆		◆				◆				T	T, S	42
3292	◆			◆				◆				T	T, S	43
3296	◆			◆				◆				T, R	T, S	44
3299	◆			◆				◆				T, R	T, S	48
3329	◆		◆		◆							T, R	T, S	70
3339	◆		◆				◆					T	T, S	72
3345		◆	◆					◆				B	T, S	75
3352	◆		◆					◆					T, S	76
3362	◆		◆		◆							T, R	T, S	81
3386	◆		◆					◆				T, R	T, S	85

Note 1: Standard packaging; some options may require alternate packaging. Consult factory.

T = Tubes, B = Bulk, R = Tape and Reel

Note 2: T = Top Adjust, S = Side Adjust

Consumer / Open Frame Trimmers

Model Number	Element Technology		Mounting Type		Size						Packaging Options	Adjust	Page No.
	Cermet	Carbon	SMT	Leaded	2 mm	3 mm	4 mm	6 mm	9 mm	3/8 "	See Note 1	See Note 2	
3302	◆		◆		◆						E	T	49
3303	◆		◆			◆					E	T, B	50
3306	◆			◆				◆			B	T, S	52
3309	◆			◆					◆		B	T, S, B	53
3318PSGB		◆		◆				◆			B	T, S, B	62
3318FK		◆		◆				◆			B	T, S, B	66
3319		◆		◆					◆		B	T, S	68
3352	◆			◆						◆	B	T, S	76
3364	◆		◆				◆				E	T	83
TC03	◆		◆			◆					E	T	90
TC22	◆		◆		◆						E	T	91
TC33	◆		◆			◆					E	T	92
TC73		◆	◆			◆					E	T	93
TC86	◆			◆				◆			B	T, S	94
TC89	◆			◆					◆		B	T, S, B	96

Note 1: Standard packaging; some options may require alternate packaging. Consult factory.

E = 7" Reel, B = Bulk

Note 2: T = Top Adjust, S = Side Adjust, B = Bottom Adjust

Military Trimmers

Model Number	Element Technology		Size				Packaging Options	Adjust	Page No.
	Cermet	Carbon	1/4 "	3/8 "	1/2 "	1-1/4 "	See Note 1	See Note 2	
RT12		◆				◆	T, B	S	103
RT/RTR22		◆			◆		T	T, S	104
RT/RTR24		◆		◆			T	T, S	105
RT26		◆	◆				T	T, S	106
RJ12	◆					◆	T, B	S	107
RJ22	◆				◆		T	T, S	108
RJ/RJR24	◆			◆			T	T, S	109
RJ/RJR26	◆		◆				T	T, S	110
RJ/RJR50	◆		◆				T	T	111

Note 1: Standard packaging; some options may require alternate packaging. Consult factory.

T = Tube, B = Bulk

Note 2: T = Top Adjust, S = Side Adjust

Application Specific Products

Model Number	Element Technology		Number of Turns		Application	Packaging Options	Adjust	Page No.
	Cermet	WW	Single	Multi		See Note 1	See Note 2	
3296-LC2*	◆			◆	Low Current <50 uA	T	T, S	46
3296-OT1*	◆			◆	Operational Amplifier Voltage Adjustment	T	T, S	47
3386-HV2	◆		◆		High Voltage 1K VDC Max.	T	T, S	88
3386-HV3	◆		◆		High Voltage 600 VDC Max.	T	T, S	88
3386-OT1*	◆		◆		Operational Amplifier Voltage Adjustment	T, B	T	89

Note 1: Standard packaging; some options may require alternate packaging. Consult factory.

T = Tubes, B = Bulk

Note 2: T = Top Adjust, S = Side Adjust

*Indicates patented models

Optional Products

Optional Products

These optional trimmers are not recommended for new designs. However, a detailed data sheet can be found on the Bourns website.

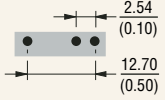
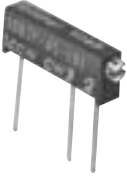
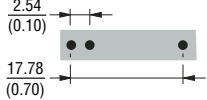
Model Number	Products	Mounting		Size	Circuit Board Layout
		Surface Mount	Through-Hole		
20			◆	20 mm Rectangular	
3082			◆	1/2" Rectangular	

Trimmer Data Sheets



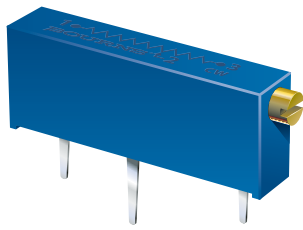

BOURNS®

3005 3/4" Rectangular Trimming Potentiometer

Features

- Multiturn / Wirewound / Industrial / Sealed
- Sealed to prevent contamination from fluxing, soldering and cleaning
- Low cost model
- Panel mount option available

■ RoHS compliant†

Electrical Characteristics

Standard Resistance Range10 to 50K ohms
 (see standard resistance table)
 Resistance Tolerance±10 % std.
 (tighter tolerance available)
 Absolute Minimum Resistance
0.5 % or 1 ohms max.
 (whichever is greater)
 Noise.....100 ohms ENR max.
 Resolution ...See standard resistance table
 Insulation Resistance500 vdc.
 100 megohms min.
 Dielectric Strength
 Sea Level1,000 vac
 80,000 Feet.....250 vac
 Adjustment Travel20 turns nom.

Environmental Characteristics

Power Rating
 70 °C1 watt
 125 °C0 watt
 Temperature Range.....-65 °C to +125 °C
 Temperature Coefficient±50 ppm/°C
 Seal Test.....85 °C Fluorinert*
 Humidity.....MIL-STD-202 Method 106
 96 hours
 (5 % ΔTR, 20 megohms IR)
 Vibration20 G (2 % ΔTR; 2 % ΔVR)
 Shock50 G (2 % ΔTR; 2 % ΔVR)
 Load Life.....1,000 hours, 1 watt @ 70 °C
 (3 % ΔTR)
 Rotational Life.....200 cycles
 (4 % ΔTR)

Physical Characteristics

Torque5.0 oz-in. max.
 Mechanical Angle.....Wiper idles
 TerminalsSolderable pins
 Weight0.045 oz.
 MarkingManufacturer's trademark,
 resistance code, wiring diagram,
 date code, manufacturer's model
 number and style
 Standard Packaging25 pcs. per tube

Product Dimensions

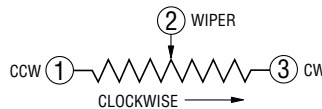
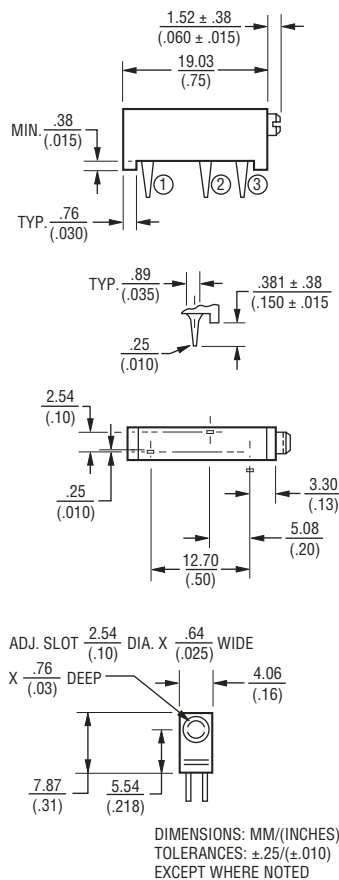

Standard Resistance Table

Resistance (Ohms)	Resistance Code	Nominal Resolution (Percent)
10	100	1.7
20	200	1.5
50	500	1.0
100	101	0.8
200	201	0.7
500	501	0.5
1,000	102	0.5
2,000	202	0.4
5,000	502	0.3
10,000	103	0.3
20,000	203	0.2
50,000	503	0.2

Special resistances available from 10 to 50K ohms.

How To Order

3005 P - 1 - 103 Z

Model _____
 Style _____
 Standard or Modified _____
 Product Indicator _____
 -1 = Standard Product
 Resistance Code _____
 Optional Suffix Letter _____
 Z = Panel Mount (Factory Installed)
 Consult factory for other available options.

†"Fluorinert" is a registered trademark of 3M Co.
 †RoHS Directive 2002/95/EC Jan 27 2003 including Annex.
 Specifications are subject to change without notice.
 Customers should verify actual device performance in
 their specific applications. REV 09/04

AVAILABLE THROUGH DISTRIBUTION

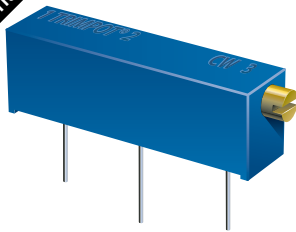

BOURNS®

3006 Trimpot® Trimming Potentiometer

Features

- 3/4" Rectangular / Multiturn / Cermet / Industrial / Sealed
- Low PC board profile - only 1/4" high
- Panel mount option available
- Transparent housing available, can be set visually without hook-up and instrumentation ("P" style only)
- RoHS compliant* version available

Electrical Characteristics

Standard Resistance Range10 to 5 megohms
 (see standard resistance table)
 Resistance Tolerance±10 % std.
 (tighter tolerance available)
 Absolute Minimum Resistance1.0 % or 2 ohms max.
 (whichever is greater)
 Contact Resistance Variation1.0 % or 1 ohm max.
 (whichever is greater)
 Adjustability
 Voltage±0.01 %
 Resistance±0.05 %
 ResolutionInfinite
 Insulation Resistance500 vdc.
 1,000 megohms min.
 Dielectric Strength
 Sea Level1,000 vac
 80,000 Feet250 vac
 Adjustment Angle15 turns nom.

Environmental Characteristics

Power Rating (400 volts max.)
 70 °C0.75 watt
 125 °C0 watt
 Temperature Range.....-55 °C to +125 °C
 Temperature Coefficient.....±100 ppm/°C
 Seal Test85 °C Fluorinert*
 Humidity.....MIL-STD-202 Method 103
 96 hours
 (3 % ΔTR, 20 Megohms IR)
 Vibration20 G (2 % ΔTR; 2 % ΔVR)
 Shock50 G (2 % ΔTR; 2 % ΔVR)
 Load Life.....1,000 hours 0.75 watt 70 °C
 (4 % ΔTR)
 Rotational Life.....200 cycles
 (3 % ΔTR; 1 % or 1 ohm, whichever is greater, CRV)

Physical Characteristics

Torque5.0 oz-in. max.
 Mechanical StopsWiper idles
 TerminalsSolderable pins
 Weight0.04 oz.
 MarkingManufacturer's trademark, resistance code, terminal numbers, date code, manufacturer's model number and style
 Wiper.....50 % (Actual TR) ±10 %
 FlammabilityU.L. 94V-0
 Standard Packaging25 pcs. per tube
 Adjustment ToolH-90

*"Fluorinert" is a registered trademark of 3M Co.
 *RoHS Directive 2002/95/EC Jan 27 2003 including Annex. Specifications are subject to change without notice.
 Customers should verify actual device performance in their specific applications. REV 09/04

Product Dimensions

Common Dimensions

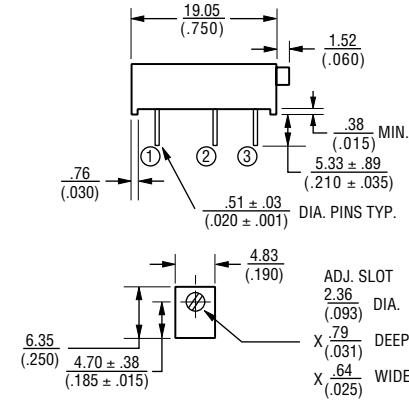

3006P

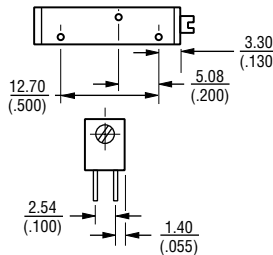

3006W

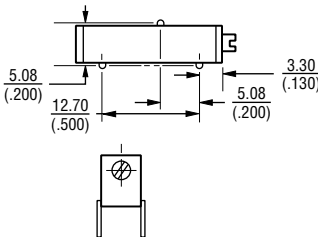

3006Y

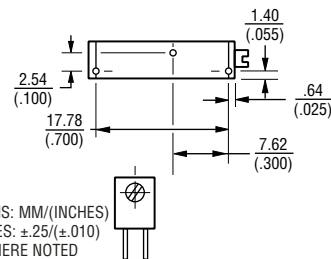

DIMENSIONS: MM/(INCHES)
 TOLERANCES: ±.25/(±.010)
 EXCEPT WHERE NOTED

Standard Resistance Table

Resistance (Ohms)	Resistance Code
10	100
20	200
50	500
100	101
200	201
500	501
1,000	102
2,000	202
5,000	502
10,000	103
20,000	203
25,000	253
50,000	503
100,000	104
200,000	204
250,000	254
500,000	504
1,000,000	105
2,000,000	205

Popular distribution resistance values listed in **boldface**. Special resistances available.

How To Order

Model **3006 P - 1 - 103 Z LF**
 Style _____
 Standard or Modified _____
 Product Indicator _____
 -1 = Standard Product
 -7 = Transparent Housing
 Resistance Code _____
 Optional Suffix Letter _____
 Z = Panel Mount (Factory Installed)
 Terminations _____
 LF = 100 % Tin-plated (RoHS compliant)
 Blank = 90 % Tin / 10 % Lead-plated (Standard)
 Consult factory for other available options.

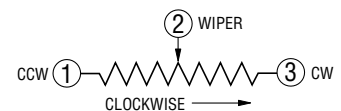

Trimmer Data Sheets

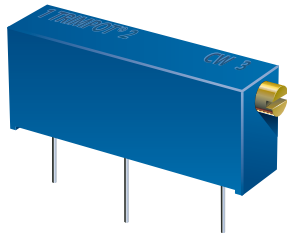

BOURNS®

3009 3/4" Rectangular Trimming Potentiometer

Features

- Multiturn / Cermet / Industrial / Sealed
- Low temperature coefficient: ± 100 ppm/°C
- Stable, infinite resolution cermet element
- CRV 1.0 % or 1 ohm
- Panel mount option available
- RoHS compliant* version available

Electrical Characteristics

Standard Resistance Range10 to 2 megohms
(see standard resistance table)
Resistance Tolerance ± 10 % std.
(tighter tolerance available)
Absolute Minimum Resistance1.0 % or 2 ohms max.
(whichever is greater)
Contact Resistance Variation1.0 % or 1 ohm max.
(whichever is greater)
Adjustability
Voltage ± 0.01 %
Resistance ± 0.05 %
ResolutionInfinite
Insulation Resistance500 vdc
100 megohms min.
Dielectric Strength
Sea Level1,000 vac
80,000 Feet250 vac
Adjustment Angle15 turns nom.

Environmental Characteristics

Power Rating (400 volts max.)
70 °C0.75 watt
150 °C0 watt
Temperature Range-55 °C to +150 °C
Temperature Coefficient ± 100 ppm/°C
Seal Test85 °C Fluorinert*
HumidityMIL-STD-202 Method 103
96 hours
(3 % Δ TR, 20 megohms IR)
Vibration20 G (2 % Δ TR; 2 % Δ VR)
Shock50 G (2 % Δ TR; 2 % Δ VR)
Load Life1,000 hours, 0.75 watt @ 70 °C
(4 % Δ TR)
Rotational Life200 cycles
(3 % Δ TR; 1 % or 1 ohm,
whichever is greater, CRV)

Physical Characteristics

Torque5.0 oz-in. max.
Mechanical StopsWiper idles
TerminalsSolderable pins
Weight0.05 oz.
MarkingManufacturer's
trademark, resistance code,
terminal numbers, date code,
manufacturer's model number
and style
Standard Packaging25 pcs. per tube

Product Dimensions

3009P

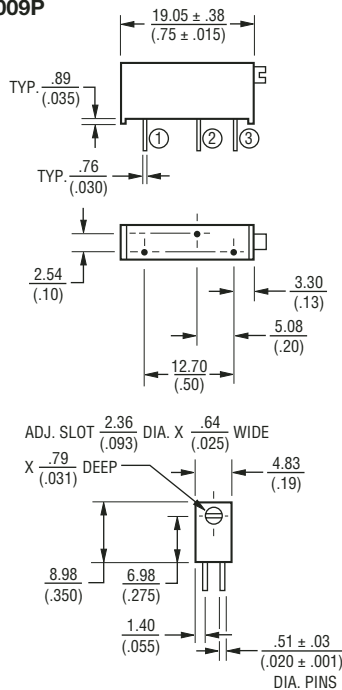

3009Y

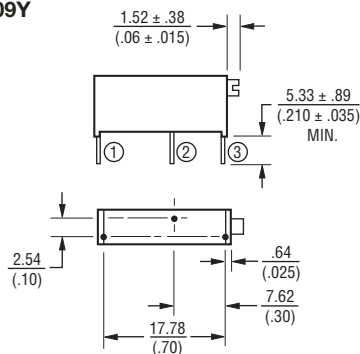

DIMENSIONS: MM/(INCHES)
TOLERANCES: $\pm .25/(\pm .010)$
EXCEPT WHERE NOTED

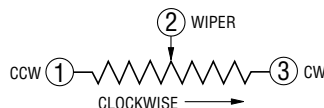

Standard Resistance Table

Resistance (Ohms)	Resistance Code
10	100
20	200
50	500
100	101
200	201
500	501
1,000	102
2,000	202
5,000	502
10,000	103
20,000	203
25,000	253
50,000	503
100,000	104
200,000	204
250,000	254
500,000	504
1,000,000	105
2,000,000	205

How To Order

3009 P - 1 - 103 Z LF

Model _____
Style _____
Standard or Modified _____
Product Indicator _____
-1 = Standard Product
-11 = 5 % Resistance Tolerance
Resistance Code _____
Optional Suffix Letter _____
Z = Panel Mount (Factory Installed)
Terminations _____
LF = 100 % Tin-plated (RoHS compliant)
Blank = 90 % Tin / 10 % Lead-plated
(Standard)
Consult factory for other available options.

*"Fluorinert" is a registered trademark of 3M Co.
*RoHS Directive 2002/95/EC Jan 27 2003 including Annex.
Specifications are subject to change without notice.
Customers should verify actual device performance in
their specific applications. REV 09/04

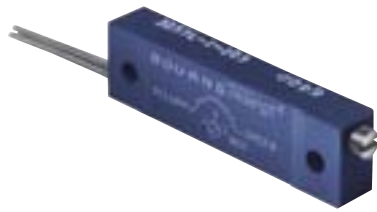

BOURNS®

3057 Trimpot® Trimming Potentiometer

Features

- 1-1/4" Rectangular / Multiturn / Wirewound / Industrial / Sealed
- Panel mount option available
- Listed on the QPL for style RT12 per MIL-PRF-27208
- RoHS compliant*

Electrical Characteristics

Standard Resistance Range 10 to 50K ohms
 (see standard resistance table)
 Resistance Tolerance ±5 % std.
 (tighter tolerance available)
 Absolute Minimum Resistance 0.1 % or 1 ohm max.
 (whichever is greater)
 Noise 100 ohms ENR max.
 Resolution See Resistance Table
 Insulation Resistance 500 vdc.
 1,000 megohms min.
 Dielectric Strength
 Sea Level 1,500 vac
 70,000 Feet 400 vac
 Adjustment Travel 22 turns nom.

Environmental Characteristics

Power Rating @ 70 °C 1 watt
 Power Rating @ 150 °C 0 watt
 Temperature Range -55 °C to +150 °C
 Temperature Coefficient ±50 ppm/°C
 Seal Test 85 °C Fluorinert[®]
 (pin styles only)
 Humidity MIL-STD-202 Method 106
 96 hours
 2 % ΔTR, 100 Megohms IR)
 Vibration 30 G (1 % ΔTR; 0.5 %
 + resolution ΔVR)
 Shock 100 G (1 % ΔTR; 0.5 %
 + resolution ΔVR)
 Load Life 1,000 hours 1 watt @ 70 °C
 (2 % ΔTR)
 Rotational Life 200 cycles (2 % ΔTR)

Physical Characteristics

Torque 5.0 oz-in. max.
 Mechanical Stops Wiper idles
 Terminals Solderable pins and lugs
 Flexible leads (7 strands of 30 AWG)
 Weight 0.10 oz.
 Marking Manufacturer's trademark,
 resistance code, terminal numbers,
 date code, manufacturer's model
 number and style
 Wiper 50 % (Actual TR) ±10 %
 Flammability U.L. 94V-0
 Standard Packaging
 P&Y Style 10 pcs. per tube
 L&J Style 25 pcs. per bag
 Adjustment Tool H-90

*"Fluorinert" is a registered trademark of 3M Co.
 *RoHS Directive 2002/95/EC Jan 27 2003 including Annex.
 Specifications are subject to change without notice.
 Customers should verify actual device performance in
 their specific applications. REV 09/04

Product Dimensions

3057L

Common Dimensions

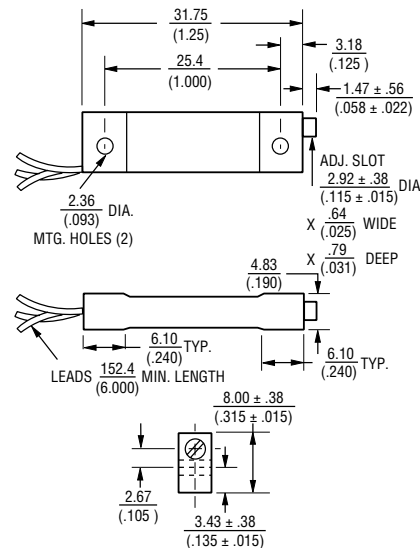

3057J

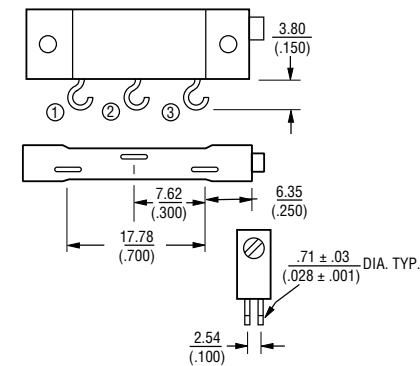

3057P

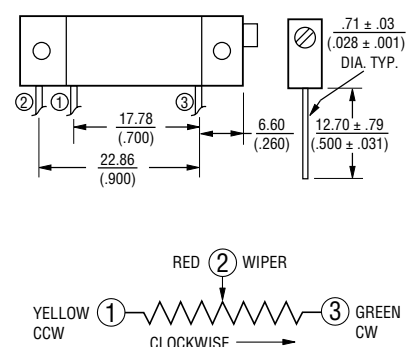

3057Y

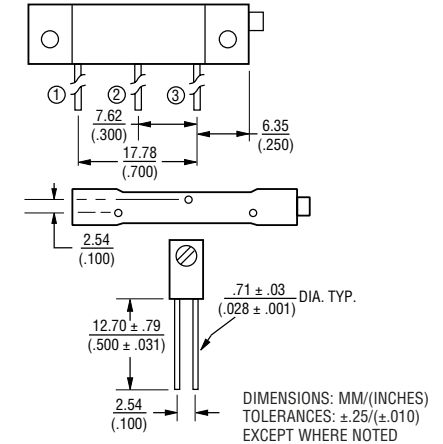

Standard Resistance Table

Resistance (Ohms)	Resistance Code	Nominal Resolution (Percent)
10	100	2.40
20	200	1.90
50	500	1.40
100	101	1.00
200	201	0.86
500	501	0.89
1,000	102	0.72
2,000	202	0.58
5,000	502	0.43
10,000	103	0.34
20,000	203	0.31
50,000	503	0.24

Popular distribution resistance values listed in **boldface**.
 Special resistances available.

How To Order

3057 L - 1 - 103 M

Model _____
 Style _____
 Standard or Modified _____
 Product Indicator _____
 -1 = Standard Product
 Resistance Code _____
 Optional Suffix Letter _____
 M = Panel Mount (Factory Installed)

Trimmer Data Sheets

AVAILABLE THROUGH DISTRIBUTION

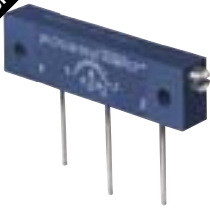

BOURNS®

3059 Trimpot® Trimming Potentiometer

Features

- 1-1/4" Rectangular / Multiturn Cermet / Industrial / Sealed
- Panel mount option available
- Listed on the QPL for style RJ12 per MIL-PRF-22097
- RoHS compliant† version available

Electrical Characteristics

Standard Resistance Range10 to 2 megohms
 (see standard resistance table)
 Resistance Tolerance±10 % std.
 (tighter tolerance available)
 Absolute Minimum Resistance1 % or 2 ohms max.
 (whichever is greater)
 Contact Resistance Variation1.0 % or 1 ohm max.
 (whichever is greater)
 Adjustability
 Voltage±0.01 %
 Resistance±0.05 %
 ResolutionInfinite
 Insulation Resistance500 vdc.
 1,000 megohms min.
 Dielectric Strength
 Sea Level900 vac
 70,000 Feet350 vac
 Effective Travel22 turns nom.

Environmental Characteristics

Power Rating @ 70 °C (400 volts max.)1.0 watt
 Power Rating @ 150 °C0 watt
 Temperature Range-55 °C to +150 °C
 Temperature Coefficient±100 ppm/°C
 Seal Test85 °C Fluorinert*
 (pin styles only)
 HumidityMIL-STD-202 Method 106
 (2 % ΔTR, 10 Megohms IR)
 Vibration20 G (1 % ΔTR; 1 % ΔVR)
 Shock50 G (1 % ΔTR; 1 % ΔVR)
 Load Life1,000 hours 1.0 watt @ 70 °C
 (3 % ΔTR; 1 % or 1 ohms, whichever is greater, CRV)
 Rotational Life200 cycles
 (2 % ΔTR; 1 % or 1 ohm, whichever is greater, CRV)

Physical Characteristics

Torque5.0 oz-in. max.
 Mechanical StopsWiper idles
 TerminalsSolderable printed circuit pins
 Flexible leads(7 strands of 30 AWG)
 Weight0.1 oz.
 MarkingManufacturer's trademark, resistance code, terminal numbers, date code, manufacturer's model number and style
 Wiper50 % (Actual TR) ±10 %
 FlammabilityU.L. 94V-0
 Standard Packaging
 P&Y Styles10 pcs. per tube
 L&J Styles25 pcs. per bag
 Adjustment ToolH-90

3059L

Common Dimensions

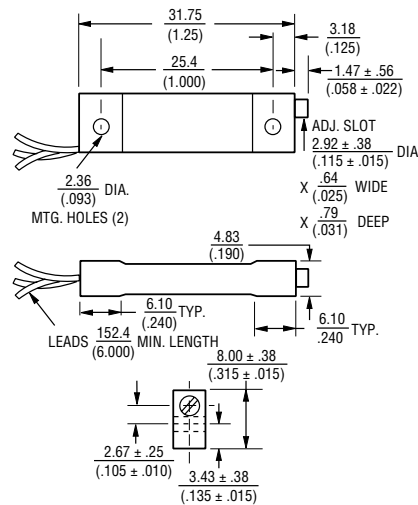

3059J

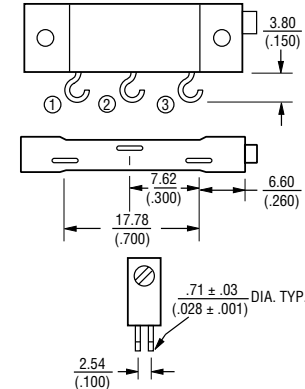

3059P

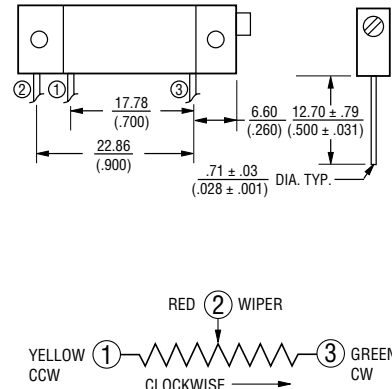

3059Y

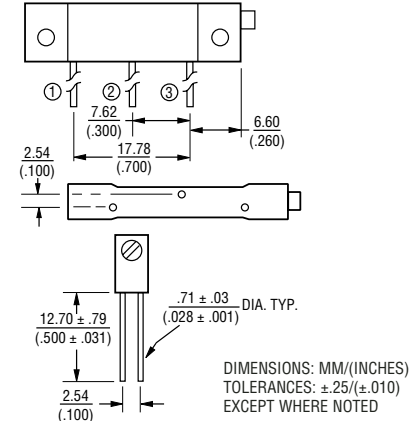

Standard Resistance Table

Resistance		Resistance	
Ohms	Code	Ohms	Code
10	100	20,000	203
20	200	25,000	253
50	500	50,000	503
100	101	100,000	104
200	201	200,000	204
500	501	250,000	254
1,000	102	500,000	504
2,000	202	1,000,000	105
5,000	502	2,000,000	205
10,000	103		

Popular distribution resistance values listed in **boldface**. Special resistances available.

How To Order

Model 3059 L - 1 - 103 M LF
 Style _____
 Standard or Modified Product Indicator _____
 -1 = Standard Product
 Resistance Code _____
 Optional Suffix Letter _____
 M = Panel Mount (Factory Installed)
 Terminations _____
 LF = 100 % Tin-plated (RoHS compliant)
 Blank = 90 % Tin / 10 % Lead-plated (Standard)

††Fluorinert™ is a registered trademark of 3M Co.
 †RoHS Directive 2002/95/EC Jan 27 2003 including Annex. Specifications are subject to change without notice. Customers should verify actual device performance in their specific applications. REV 09/04

Trimmer Data Sheets

AVAILABLE THROUGH DISTRIBUTION

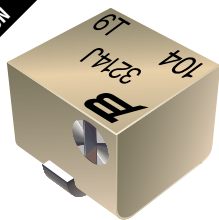

BOURNS®

3214 – 5-Turn Trimming Potentiometer

Features

- Surface Mount 4 mm Square / Multiturn / Cermet / Industrial / Sealed
- Sealed to withstand board wash processing
- Pick and place centering design, with flush adjustment
- 4 mm design meets EIA/EIAJ/IPC/VECI SMD standard trimmer footprint
- Patent #5047746 advanced drive/wiper mechanism
- RoHS compliant[†] - see page 155 for processing information on lead free surface mount trimmers

Electrical Characteristics

Standard Resistance Range 10 to 2 megohms (see standard resistance table)
 Resistance Tolerance ±10 % std.
 Absolute Minimum Resistance 1 % or 2.0 ohms (whichever is greater)
 Contact Resistance Variation 3 % or 3 ohms max.
 Resolution Essentially Infinite
 Insulation Resistance 500 vdc. 100 megohms min.
 Dielectric Strength
 Sea Level 600 vac (1minute)
 Adjustment Angle 5 turns nom.

Environmental Characteristics

Power Rating (300 volts max.)
 85 °C 0.25 watt
 150 °C 0 watt
 Temperature Range -65 °C to +150 °C
 Temperature Coefficient ±100 ppm/°C
 Humidity MIL-STD 202 Method 106 TRS ±2 %; IR 10 megohms
 Vibration 20 G TRS ±1 %; VRS ±1 %
 Shock 100 G TRS ±1 %; VRS ±1 %
 Load Life @ 85 °C rated power 1,000 hours TRS 3 ohms or 3 % (whichever is greater)
 Rotational Cycling 200 cycles TRS 3 ohms or 3 % (whichever is greater)
 Thermal Shock 5 cycles TRS ±2 %; VRS ±1 %

Physical Characteristics

Mechanical Stop Wiper idles
 Torque 180 g-cm max.
 Weight Approximately 0.01 oz.
 Marking Manufacturer's code, resistance code and date code
 Solderability Per MIL-STD-202, Method 208
 Wiper 50 % (Actual TR) ±10 %
 Flammability UL94V0
 Pushover Strength
 J, G 4.4 lbs.
 W, X 2.2 lbs.
 Adjustment Tool H-91

How To Order

3214 J - 1 - 502 E

Model _____
 Style _____
 Standard or Modified Product Indicator _____
 -1 = Standard Product
 -2* = Wave Solderable
 -FW5 = .070" ±.010" Shaft Extension
 Resistance Code (see next page) _____
 Embossed Tape Designator _____
 E = Style J, G: 500 pcs./7" reel (standard)
 Style W: 250 pcs./7" reel (standard)
 Style X: 200 pcs./7" reel (standard)
 G = Style J, G: 1500 pcs./13" reel (standard)
 Style W: 1000 pcs./13" reel (standard)
 Style X: 850 pcs./13" reel (standard)
 G = Style J, G: 1500 pcs./13" reel (FW5)
 Style W, X: 600 pcs./13" reel (FW5)

Consult factory for other available options.
 * -2 has a treated stainless steel shaft

3214J Side Adjust

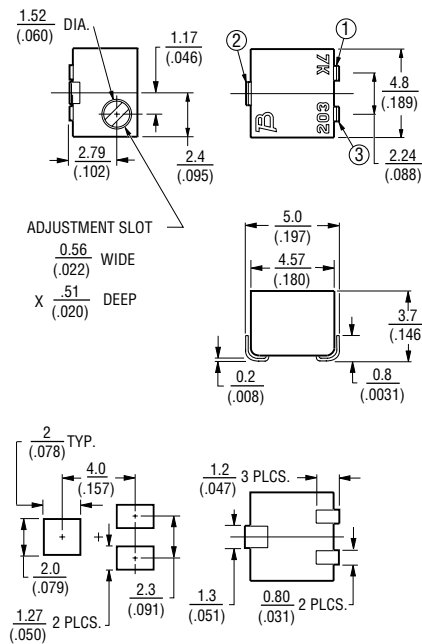

3214G Side Adjust

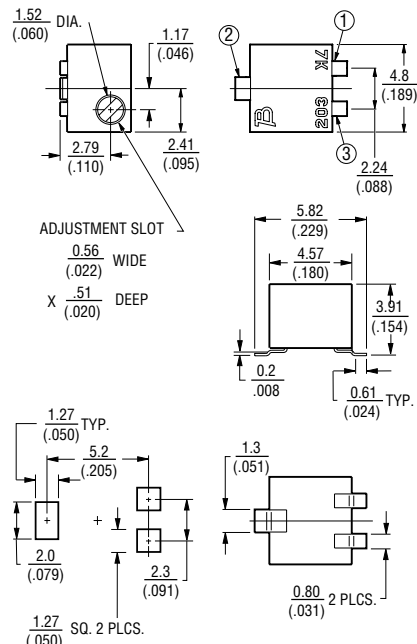

3214W Top Adjust

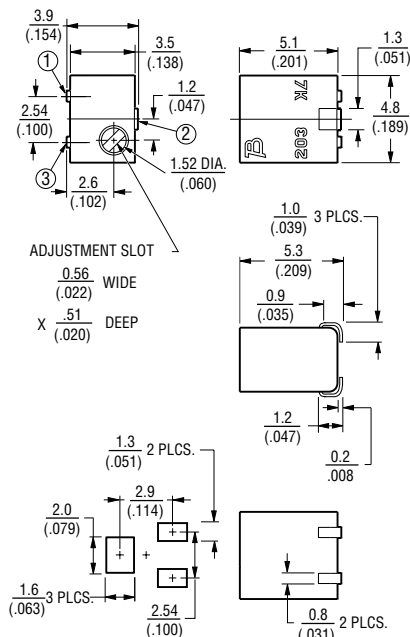

3214X Top Adjust

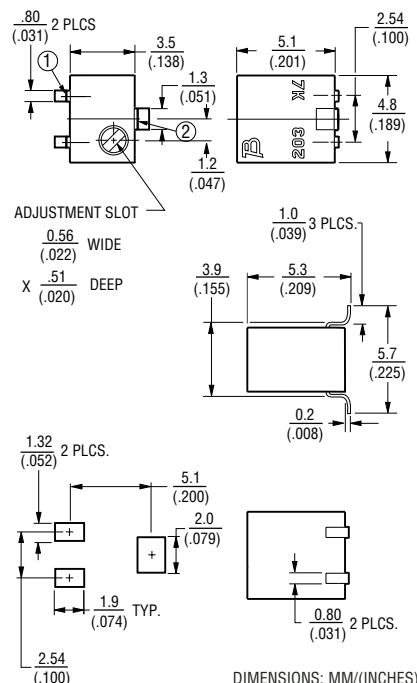

Specifications are subject to change without notice.
[†]RoHS Directive 2002/95/EC Jan 27 2003 including Annex.
 Customers should verify actual device performance in their specific applications.
 REV 09/04

DIMENSIONS: MM/(INCHES)
 TOLERANCES: ±.25/(±.010)
 EXCEPT WHERE NOTED

Trimmer Data Sheets

3214 – Packaging Specifications

J & G Styles

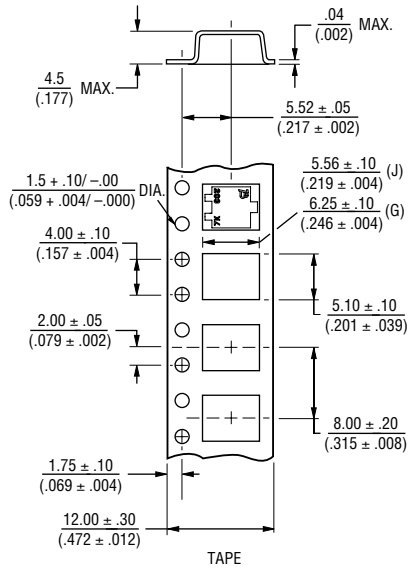

W Style

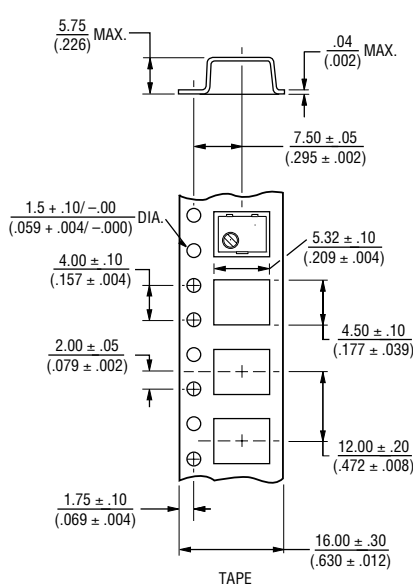

X Style

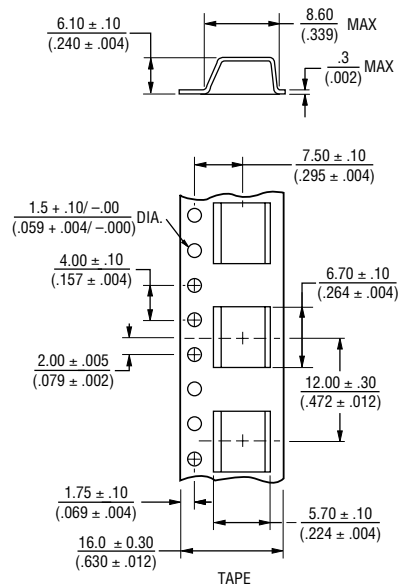

DIMENSIONS: MM/(INCHES)
TOLERANCES: ±.25/(±.010)
EXCEPT WHERE NOTED

W & X Style Reel

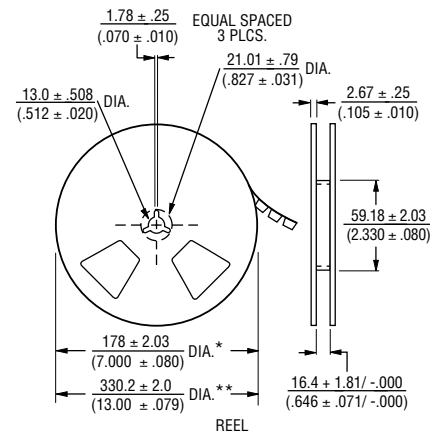

Standard Resistance Table

Resistance (Ohms)	Resistance Code
10	100
20	200
50	500
100	101
200	201
500	501
1,000	102
2,000	202
5,000	502
10,000	103
20,000	203
50,000	503
100,000	104
200,000	204
500,000	504
1,000,000	105
2,000,000	205

Popular distribution resistance values listed in **boldface**.
Special resistances available.

* Embossed Tape Designator "E"
** Embossed Tape Designator "G"
(See How To Order chart for further information.)

Cover tape peel strength: Meets EIA specification 481.

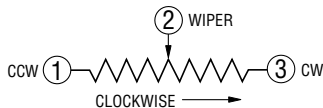

* Embossed Tape Designator "E"
** Embossed Tape Designator "G"
(See How To Order chart for further information.)

Cover tape peel strength: Meets EIA specification 481.



BOURNS®

3223 – 3 mm SMD Trimming Potentiometer

Features

- Surface Mount 3 mm Square / Multiturn / Cermet / Industrial / Sealed
- Sealed to withstand standard board wash processing
- Pick and place centering design for automated placement compatibility
- Flush adjustment screw
- Meets EIA/EIAJ/IPC/VECI SMD standard trimmer footprint
- Top adjust
- RoHS compliant* - see page 155 for processing information on lead free surface mount trimmers

Electrical Characteristics

Standard Resistance Range10 Ω to 2 MΩ
 (see standard resistance table)
 Resistance Tolerance±20 % std.
 Absolute Minimum Resistance
 ...1 % or 3 Ω max. (whichever is greater)
 Contact Resistance Variation
 ...3 % or 3 Ω max. (whichever is greater)
 Resolution.....Essentially infinite
 Insulation Resistance.....500 VDC
 (100 MΩ min.)
 Dielectric Strength
 Sea Level.....600 VAC (1 minute)
 Adjustment Angle11 turns nom.

Environmental Characteristics

Power Rating (200 volts max.)
 70 °C0.125 watt
 150 °C0 watt
 Temperature Range.....-65 °C to +150 °C
 Temperature Coefficient±100 ppm/°C
 Humidity.....MIL-STD-202 Method 106
 TRS ±3 %; IR 10 MΩ
 Vibration20 G TRS ±1 %; VRS ±1 %
 Shock100 G TRS ±1 %; VRS ±1 %
 Load Life
 @ 70 °C rated power 1000 hours
 CRV4 Ω or 4 % (whichever is greater)
 Rotational Cycling.....200 cycles
 CRV4 Ω or 4 % (whichever is greater)
 Thermal Shock.....5 cycles
 TRS ±2 %; VRS ±2 %

Physical Characteristics

Mechanical StopWiper idles
 Torque2.50 oz-in. max
 WeightApproximately 0.01 oz.
 MarkingManufacturer's code,
 resistance code and date code
 SolderabilityPer MIL-STD-202,
 Method 208
 Wiper.....50 % (Actual TR) ±10 %
 FlammabilityUL94V-0
 Adjustment Tool.....H-92-1

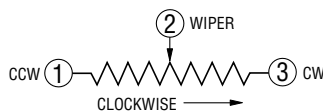

Specifications are subject to change without notice.
 *RoHS Directive 2002/95/EC Jan 27 2003 including Annex.
 Customers should verify actual device performance in
 their specific applications. REV 09/04

Product Dimensions

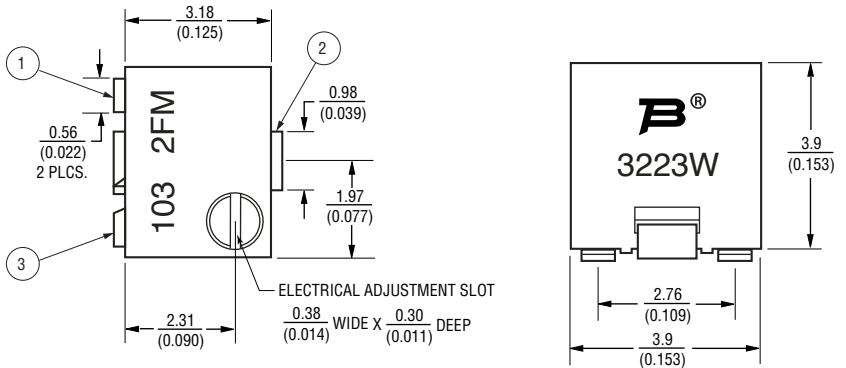

Recommended Land Pattern

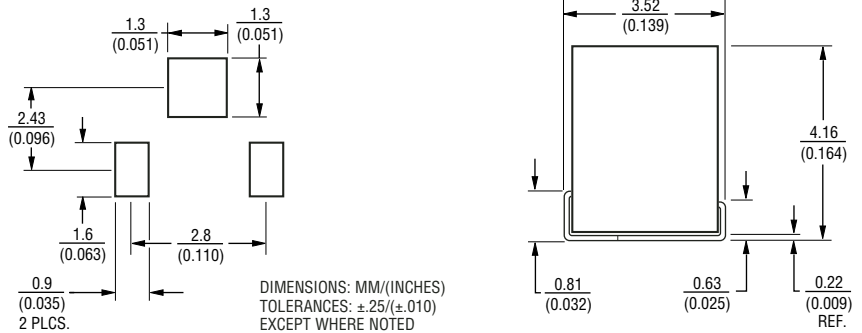

Standard Resistance Table

Resistance		Resistance	
Ohms	Code	Ohms	Code
10	100	10,000	103
20	200	20,000	203
50	500	50,000	503
100	101	100,000	104
200	201	200,000	204
500	501	500,000	504
1,000	102	1,000,000	105
2,000	202	2,000,000	205
5,000	502		

Popular distribution resistance values listed in **boldface**.
 Special resistances available.

How To Order

Model **3223 W - 1 - 502 E**
 Style _____
 Standard or Modified _____
 Product Indicator _____
 -1 = IR Reflow (Standard)
 Resistance Code _____
 Embossed Tape Designator _____
 E = 500 pcs./7" reel (standard)

AVAILABLE THROUGH DISTRIBUTION

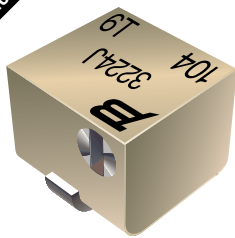

BOURNS®

3224 4 mm SMD Trimming Potentiometer

Features

- Surface Mount 4 mm Square / Multiturn / Cermet / Industrial / Sealed
- Sealed to withstand board wash processing
- Pick and place centering design, with flush adjustment
- 4 mm design meets EIA/EIAJ/IPC/VECI SMD standard trimmer footprint
- Low CRV - 1 %
- DESC selected material drawing #92021
- RoHS compliant[†] - see page 155 for processing information on lead free surface mount trimmers

Electrical Characteristics

Standard Resistance Range10 to 2 megohms
 (see standard resistance table)
 Resistance Tolerance.....±10 % std.
 Absolute Minimum Resistance1 % or 2.0 ohms (whichever is greater)
 Contact Resistance Variation1 % or 3 ohms max.
 ResolutionEssentially Infinite
 Insulation Resistance.....500 vdc.
 100 megohms min.
 Dielectric Strength
 Sea Level.....600 vac (1 minute)
 Adjustment Angle.....11 turns nom.

Environmental Characteristics

Power Rating (300 volts max.)
 85 °C.....0.25 watt
 150 °C.....0 watt
 Temperature Range-65 °C to +150 °C
 Temperature Coefficient.....±100 ppm/°C
 HumidityMIL-STD 202 Method 106
 TRS ±2 %; IR 10 megohms
 Vibration.....20 G TRS±1 %; VRS ±1 %
 Shock.....100 G TRS ±1 %; VRS±1 %
 Load Life....@ 85 °C rated power 1,000 hours
 TRS3 ohms or 3 % (whichever is greater)
 Rotational Cycling200 cycles
 TRS3 ohms or 3 % (whichever is greater)
 Thermal Shock ..5 cycles, TRS±2 %; VRS±1 %

Physical Characteristics

Mechanical Stop.....Wiper idles
 Torque180 g-cm max.
 Weight.....Approximately 0.01 oz.
 Marking.....Manufacturer's code, resistance code and date code
 Solderability ...Per MIL-STD-202, Method 208
 Wiper50 % (Actual TR) ±10 %
 Flammability.....UL94V0
 Pushover Strength
 J, G.....4.4 lbs.
 W, X.....2.2 lbs.
 Adjustment Tool.....H-91

How To Order

3224 J - 1 - 502 E

Model _____
 Style _____
 Standard or Modified Product Indicator _____
 -1 = IR Reflow (standard)
 -2* = Wave Solderable
 -FW5 = .070" ±.010" Shaft Extension
 Resistance Code _____
 Embossed Tape Designator _____
 E = Style J, G: 500 pcs./7" reel (standard)
 Style W: 250 pcs./7" reel (standard)
 Style X: 200 pcs./7" reel (standard)
 G = Style J, G: 1500 pcs./13" reel (standard)
 Style W: 1000 pcs./13" reel (standard)
 Style X: 850 pcs./13" reel (standard)
 G = Style J, G: 1500 pcs./13" reel (FW5)
 Style W, X: 600 pcs./13" reel (FW5)

Consult factory for other available options.
 * -2 has a treated stainless steel shaft

Product Dimensions

3224J Side Adjust

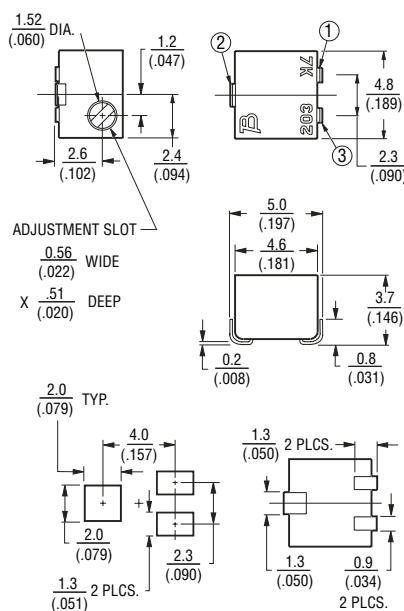

3224W Top Adjust

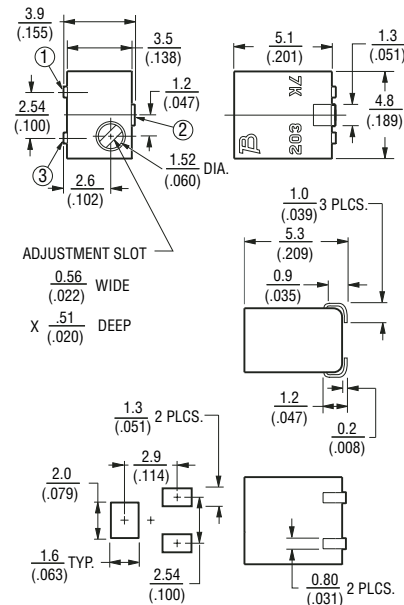

3224G Side Adjust

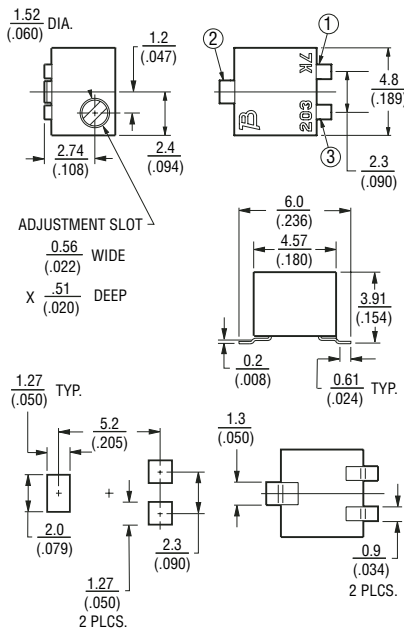

3224X Top Adjust

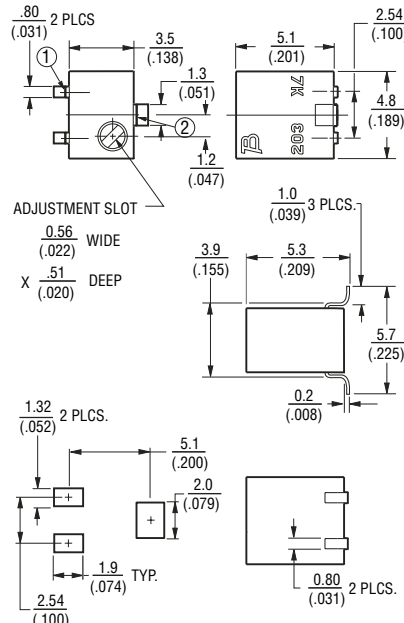

Specifications are subject to change without notice.
[†]RoHS Directive 2002/95/EC Jan 27 2003 including Annex.
 Customers should verify actual device performance in their specific applications.
 REV 09/04

DIMENSIONS: MM/(INCHES)
 TOLERANCES: ±.25/(±.010)
 EXCEPT WHERE NOTED

Additional Features

- Top and side adjust styles
- J-hook, and gull-wing
- Patent #5047746 advanced drive/wiper mechanism

3224 – Packaging Specifications

J & G Styles

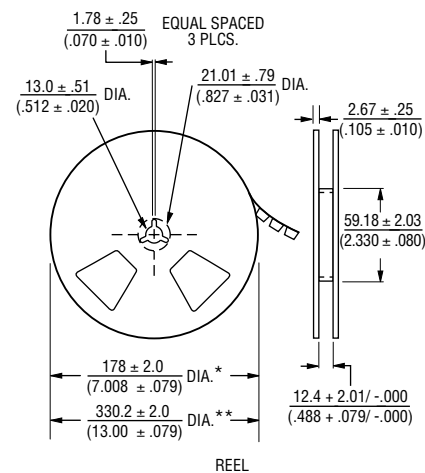
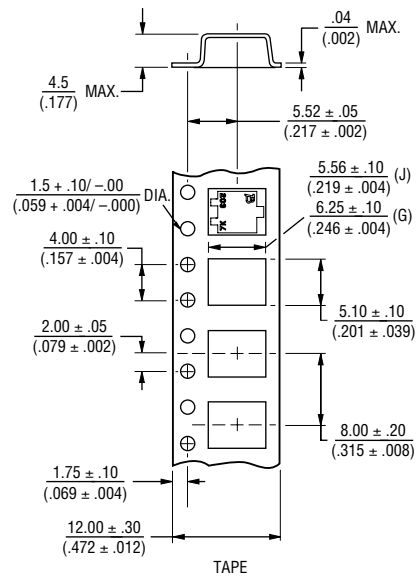

* Embossed Tape Designator 'E'
 ** Embossed Tape Designator 'G'
 (See How To Order chart for further information.)

Cover tape peel strength: Meets EIA specification 481.

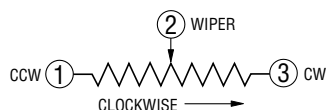

W Style

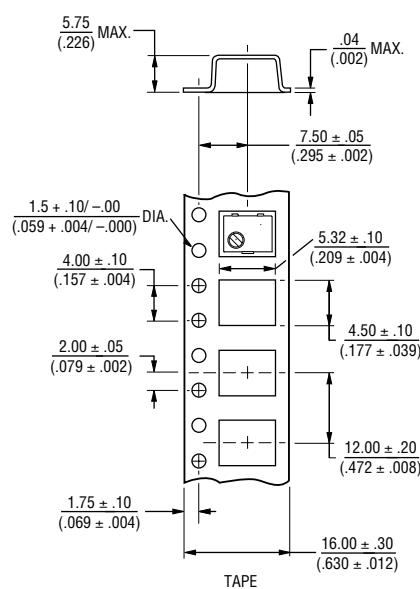

W & X Style Reel

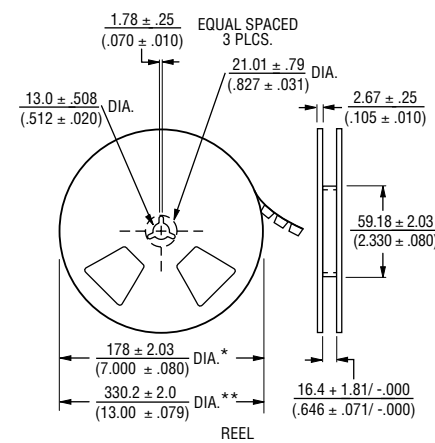

* Embossed Tape Designator 'E'
 ** Embossed Tape Designator 'G'
 (See How To Order chart for further information.)

Cover tape peel strength: Meets EIA specification 481.

Specifications are subject to change without notice.
 Customers should verify actual device performance in their specific applications.

X Style

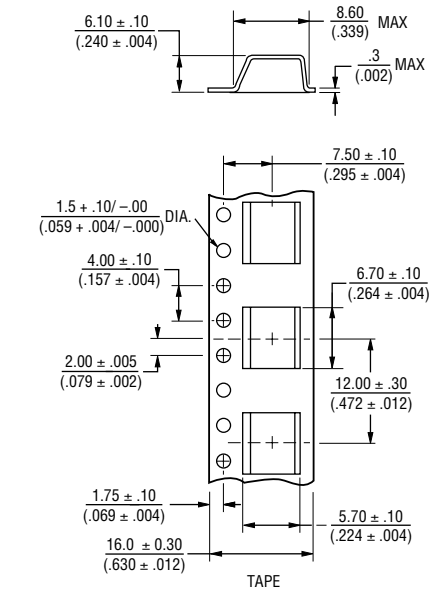

DIMENSIONS: MM/(INCHES)
 TOLERANCES: ±.25/(±.010)
 EXCEPT WHERE NOTED

Standard Resistance Table

Resistance (Ohms)	Resistance Code
10	100
20	200
50	500
100	101
200	201
500	501
1,000	102
2,000	202
5,000	502
10,000	103
20,000	203
50,000	503
100,000	104
200,000	204
500,000	504
1,000,000	105
2,000,000	205

Popular distribution resistance values listed in **boldface**.
 Special resistances available.

AVAILABLE THROUGH DISTRIBUTION

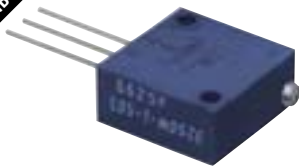

BOURNS®

3250 1/2" Square Trimming Potentiometer

Features

- Multiturn / Wirewound / Sealed
- Listed on the QPL for style RT22 per MIL-R-27208 and RTR22 per High-Rel MIL-R-39015
- Panel Mount option available
- RoHS compliant*

Electrical Characteristics

Standard Resistance Range10 to 50K ohms (see standard resistance table)
 Resistance Tolerance±5 % std. (tighter tolerance available)
 Absolute Minimum Resistance0.1 % or 1 ohm max. (whichever is greater)
 Noise100 ohms ENR max.
 ResolutionSee Resistance Table
 Insulation Resistance500 vdc, 1,000 megohms min.
 Dielectric Strength
 Sea Level1,000 vac
 80,000 Feet400 vac
 Adjustment Travel25 turns nom.

Environmental Characteristics

Power Rating @ 85 °C1.0 watt
 Power Rating @ 150 °C0 watt
 Temperature Range-65 °C to +150 °C
 Temperature Coefficient±50 ppm/°C
 Seal Test85 °C Fluorinert* (pin styles only)
 HumidityMIL-STD-202 Method 106 (2 % ΔTR; 100 Megohms IR)
 Vibration30 G (1 % ΔTR; 0.5 % + resolution ΔVR)
 Shock100 G (1 % ΔTR; 0.5 % + resolution ΔVR)
 Load Life1,000 hours 1.0 watt @ 85 °C (2 % ΔTR; 500 ohms ENR)
 Rotational Life200 cycles (2 % ΔTR; 500 ohms ENR)

Physical Characteristics

Torque5.0 oz-in. max.
 Mechanical StopsWiper idles
 TerminalsSolderable printed circuit pins Flexible leads (7 strands of 30 AWG)
 Weight0.06 oz.
 Machine Screw Mounting
 Torque12 oz-in. max.
 MarkingManufacturer's trademark, resistance code, terminal numbers, date code, manufacturer's model number and style
 Wiper50 % (Actual TR) ±10 %
 FlammabilityU.L. 94V-0
 Standard Packaging
 P&W Styles25 pcs. per tube
 L Style25 pcs. per bag
 Adjustment ToolH-90

3250P Common Dimensions (Pin Styles)

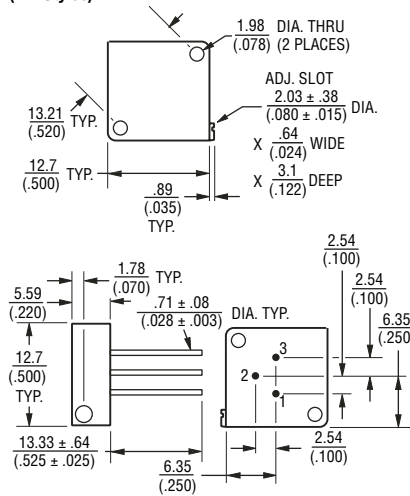

3250W

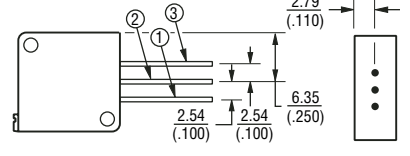

3250W-66

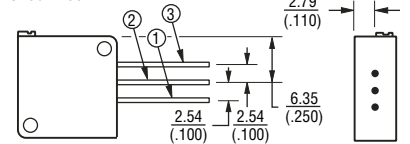

3250L

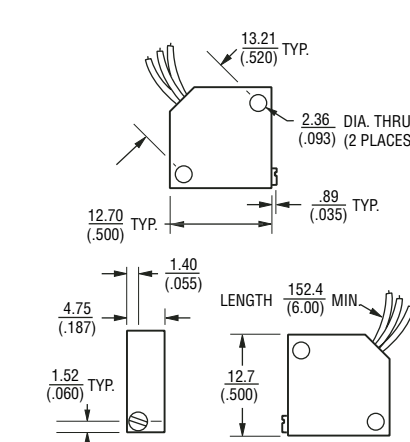

DIMENSIONS: MM/(INCHES)
 TOLERANCES: ±.25/(±.010) EXCEPT WHERE NOTED

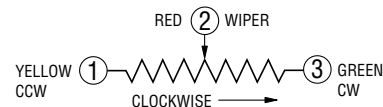

Standard Resistance Table

Resistance (Ohms)	Resistance Code	Nominal Resolution (Percent)
10	100	1.30
20	200	1.00
50	500	0.80
100	101	0.90
200	201	0.70
500	501	0.60
1,000	102	0.40
2,000	202	0.30
5,000	502	0.25
10,000	103	0.19
20,000	203	0.16
25,000	253	0.14
50,000	503	0.13

Popular distribution resistance values listed in **boldface**.
 Special resistances available.

How To Order

Model 3250 L - 1 - 103 M
 Style _____
 Standard or Modified _____
 Product Indicator _____
 -1 = Standard Product
 Resistance Code _____
 Optional Suffix Letter _____
 M = Panel Mount (Factory Installed)
 Consult factory for other available options.

*"Fluorinert" is a registered trademark of 3M Co.
 *RoHS Directive 2002/95/EC Jan 27 2003 including Annex. Specifications are subject to change without notice.
 Customers should verify actual device performance in their specific applications.
 REV 09/04

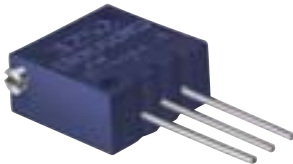

BOURNS®

3252 1/2" Square Trimming Potentiometer

Features

- Multiturn / Cermet / Sealed
- Listed on the QPL for style RJ22 per MIL-R-22097
- Panel mount option available
- RoHS compliant* version available

Electrical Characteristics

Standard Resistance Range.....10 to 2 megohms
(see standard resistance table)
Resistance Tolerance.....±10 % std.
.....(tighter tolerance available)
Absolute Minimum Resistance
.....1 % or 2 ohms max. (whichever is greater)
Contact Resistance Variation
.....1 % or 2 ohms max. (whichever is greater)
Adjustability
Voltage.....±0.01 %
Resistance.....±0.05 %
Resolution.....Infinite
Insulation Resistance.....500 vdc.
.....1,000 megohms min.
Dielectric Strength
Sea Level.....1,000 vac
80,000 Feet.....400 vac
Effective Travel.....25 turns nom.

Environmental Characteristics

Power Rating @ 85 °C (400 volts max.)
.....0.75 watt
Power Rating @ 150 °C.....0 watt
Temperature Range.....-65 °C to +150 °C
Temperature Coefficient.....±100 ppm/°C
Seal Test.....85 °C Fluorinert* (pin styles only)
Humidity.....MIL-STD-202 Method 103;
.....96 hours (1 % ΔTR; 100 Megohms IR)
Vibration.....30 G (1 % ΔTR; 1 % ΔVR)
Shock.....100 G (1 % ΔTR; 1 % ΔVR)
Load Life.....1,000 hours 0.75 watt @ 85 °C
.....(3 % ΔTR; 3 % or 3 ohms,
.....whichever is greater, CRV)
Rotational Life.....200 cycles
.....(2 % ΔTR; 3 % or 3 ohms,
.....whichever is greater, CRV)

Physical Characteristics

Torque.....5.0 oz-in. max.
Mechanical Stops.....Wiper idles
Terminals.....Solderable printed circuit pins
Flexible leads.....(7 strands of 30 AWG)
Weight.....0.065 oz.
Wiper......50 % (Actual TR) ±10 %
Flammability.....U.L. 94V-0

Machine Screw Mounting

Torque.....12 oz-in. max.
Marking.....Manufacturer's trademark,
.....resistance code, wiring diagram, date code,
.....manufacturer's model number and style
Standard Packaging
X, P&W Styles.....25 pcs. per tube
L Style.....25 pcs. per bag
Adjustment Tool.....H-90

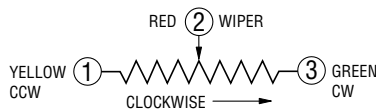

*"Fluorinert" is a registered trademark of 3M Co.
*RoHS Directive 2002/95/EC Jan 27 2003 including Annex
Specifications are subject to change without notice.
Customers should verify actual device performance in
their specific applications. REV 09/04

Product Dimensions

3252P

Common Dimensions (Pin Styles)

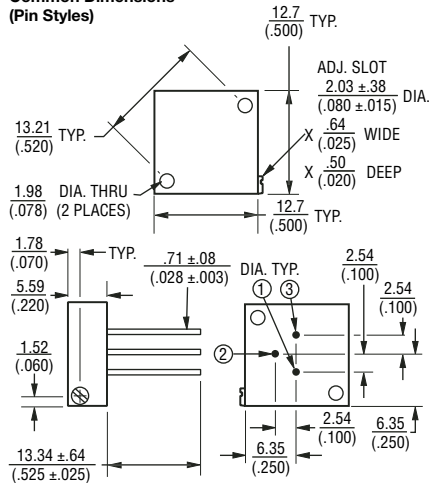

3252W

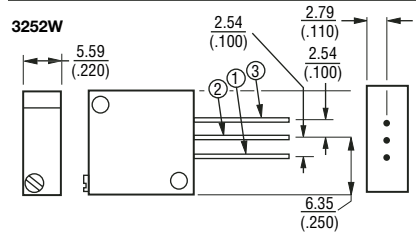

3252L

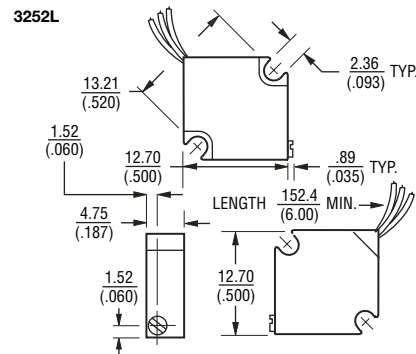

3252X

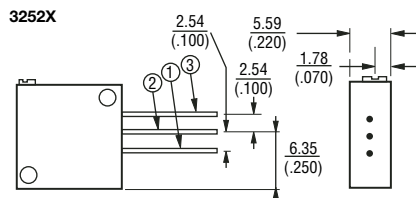

DIMENSIONS: MM/(INCHES)
TOLERANCES: ±.25(±.010) EXCEPT WHERE NOTED

Standard Resistance Table

Resistance (Ohms)	Resistance Code
10	100
20	200
50	500
100	101
200	201
500	501
1,000	102
2,000	202
5,000	502
10,000	103
20,000	203
25,000	253
50,000	503
100,000	104
200,000	204
500,000	504
1,000,000	105
2,000,000	205

Popular distribution resistance values listed in **boldface**.
Special resistances available.

How To Order

3252 L - 1 - 103 M LF

Model _____
Style _____
Standard or Modified _____
Product Indicator _____
-1 = Standard Product
Resistance Code _____
Optional Suffix Letter _____
M = Panel Mount (Factory Installed)
Terminations _____
LF = 100 % Tin-plated (RoHS compliant)
Blank = 90 % Tin / 10 % Lead-plated
(Standard)
Consult factory for other available options.

AVAILABLE THROUGH DISTRIBUTION



3260 1/4" Square Trimming Potentiometer

Features

- Multiturn / Wirewound / Industrial / Sealed
- Listed on the QPL for style RT26 per MIL-R-27208
- RoHS compliant*

BOURNS®

Electrical Characteristics

Standard Resistance Range 10 to 25K ohms
(see standard resistance table)
Resistance Tolerance ±5 % std.
(tighter tolerance available)
Absolute Minimum Resistance 0.1 % or 1 ohm max.
(whichever is greater)
Noise 100 ohms ENR max.
Resolution See resistance table
Insulation Resistance 500 vdc.
..... 1,000 megohms min.
Dielectric Strength
Sea Level 600 vac
80,000 Feet 250 vac
Adjustment Angle 11 turns nom.

Environmental Characteristics

Power Rating
85 °C 0.25 watt
150 °C 0 watt
Temperature Range -65 °C to +150 °C
Temperature Coefficient ±70 ppm/°C
Seal Test 85 °C Fluorinert*
Humidity MIL-STD-202 Method 106
..... (2 % ΔTR, 100 Megohms IR)
Vibration 30 G (1 % ΔTR; 1 %
+ resolution ΔVR)
Shock 100 G
(1 % ΔTR; 1 % + resolution ΔVR)
Load Life... 1,000 hours 0.25 watt @ 85 °C
(2 % ΔTR; 500 ohms ENR)
Rotational Life 200 cycles
(2 % ΔTR; 500 ohms ENR)

Physical Characteristics

Torque 3.0 oz-in. max.
Mechanical Stops Wiper idles
Terminals Solderable printed circuit pins
Weight 0.015 oz.
Marking Manufacturer's trademark,
resistance code, wiring diagram,
date code, manufacturer's model
number and style
Wiper 50 % (Actual TR) ±10 %
Flammability UL 94V-0
Standard Packaging 50 pcs. per tube
Adjustment Tool H-90

Product Dimensions

3260H

Common Dimensions

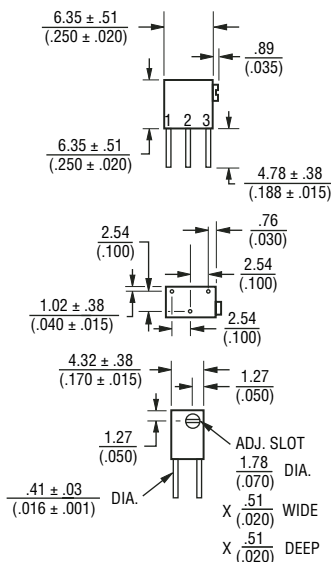

3260W

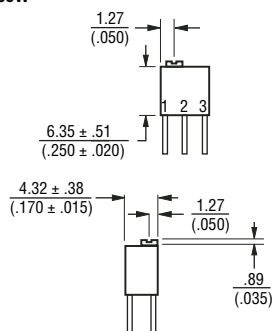

DIMENSIONS: MM/(INCHES)
TOLERANCES: ±.25/(±.010) EXCEPT WHERE NOTED

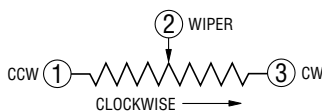

Standard Resistance Table

Resistance (Ohms)	Resistance Code	Nominal Resolution (Percent)
10	100	1.30
20	200	1.00
50	500	0.80
100	101	0.90
200	201	0.70
500	501	0.60
1,000	102	0.40
2,000	202	0.30
5,000	502	0.25
10,000	103	0.19
20,000	203	0.16
25,000	253	0.14

Popular distribution resistance values listed in **boldface**.
Special resistances available.

How To Order

3260 H - 1 - 502

Model _____
Style _____
Standard or Modified _____
Product Indicator _____
-1 = Standard Product
Resistance Code _____
Consult factory for other available options.

*"Fluorinert" is a registered trademark of 3M Co.
*RoHS Directive 2002/95/EC Jan 27 2003 including Annex.
Specifications are subject to change without notice.
Customers should verify actual device performance in
their specific applications. REV 09/04

AVAILABLE THROUGH DISTRIBUTION

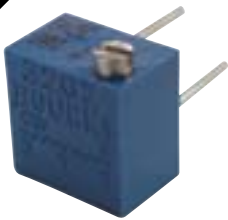

BOURNS®

3262 1/4 " Trimming Potentiometer

Features

- Multiturn / Cermet / Industrial / Sealed
- Patent #4427966 drive mechanism
- Listed on the QPL for style RJ26 per MIL-R-22097 and RJR26 per High-Rel MIL-R-39035
- RoHS compliant* version available

Electrical Characteristics

Standard Resistance Range10 to 1 megohm (see standard resistance table)
 Resistance Tolerance±10 % std. (tighter tolerance available)
 Absolute Minimum Resistance1 % or 2 ohms max. (whichever is greater)
 Contact Resistance Variation3.0 % or 3 ohms max. (whichever is greater)
 Adjustability
 Voltage±0.02 %
 Resistance±0.05 %
 ResolutionInfinite
 Insulation Resistance500 vdc. (1,000 megohms min.)
 Dielectric Strength
 Sea Level600 vac
 80,000 Feet250 vac
 Effective Travel12 turns nom.

Environmental Characteristics

Power Rating (300 volts max.)
 85 °C0.25 watt
 150 °C0 watt
 Temperature Range-65 °C to +150 °C
 Temperature Coefficient±100 ppm/°C
 Seal Test85 °C Fluorinert*
 HumidityMIL-STD-202 Method 103
 96 hours (2 % ΔTR, 100 Megohms IR)
 Vibration30 G (1 % ΔTR; 1 % ΔVR)
 Shock100 G (1 % ΔTR; 1 % ΔVR)
 Load Life...1,000 hours 0.25 watt @ 85 °C (3 % ΔTR; 3 % or 3 ohms, whichever is greater, CRV)
 Rotational Life200 cycles (2 % ΔTR; 3 % or 3 ohms, whichever is greater, CRV)

Physical Characteristics

Torque3.0 oz-in. max.
 Mechanical StopsWiper idles
 TerminalsSolderable pins
 Weight0.015 oz.
 MarkingManufacturer's trademark, resistance code, wiring diagram, date code, manufacturer's model number and style
 Wiper50 % (Actual TR) ±10 %
 FlammabilityU.L. 94V-0
 Standard Packaging50 pcs. per tube
 Adjustment ToolH-90

Product Dimensions

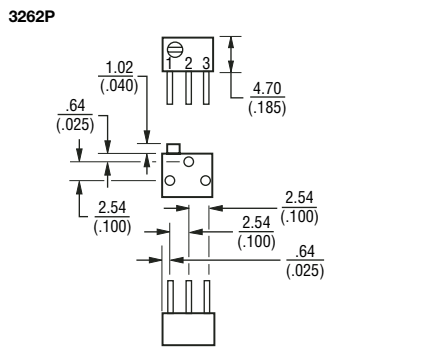
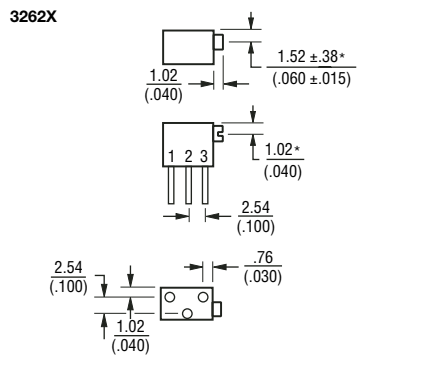
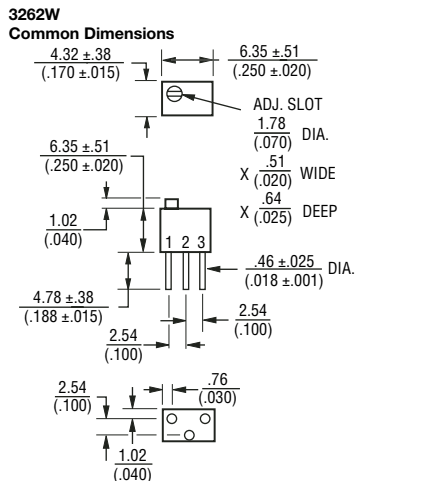

DIMENSIONS: MM/(INCHES)
 TOLERANCES: ±.25/(±.010) EXCEPT WHERE NOTED

Standard Resistance Table

Resistance (Ohms)	Resistance Code
10	100
20	200
50	500
100	101
200	201
500	501
1,000	102
2,000	202
5,000	502
10,000	103
20,000	203
25,000	253
50,000	503
100,000	104
200,000	204
250,000	254
500,000	504
1,000,000	105

Popular distribution resistance values listed in **boldface**.
 Special resistances available.

How To Order

3262 P - 1 - 103 LF

Model _____
 Style _____
 Standard or Modified Product Indicator _____
 -1 = Standard Product
 Resistance Code _____
 Terminations _____
 LF = 100 % Tin-plated (RoHS compliant)
 Blank = 90 % Tin / 10 % Lead-plated (Standard)
 Consult factory for other available options.

*"Fluorinert" is a registered trademark of 3M Co.
 *RoHS Directive 2002/95/EC Jan 27 2003 including Annex. Specifications are subject to change without notice.
 Customers should verify actual device performance in their specific applications.
 REV 09/04

Trimmer Data Sheets

AVAILABLE THROUGH DISTRIBUTION



BOURNS®

3266 1/4" Square Trimming Potentiometer

Features

- Multiturn / Cermet / Industrial / Sealed
- Standoffs allow thorough PC board washing
- Tape and reel packaging available
- Patent #4427966 drive mechanism
- RoHS compliant* version available

Electrical Characteristics

Standard Resistance Range10 to 1 megohm
(see standard resistance table)
Resistance Tolerance±10 % std.
Absolute Minimum Resistance1 % or 2 ohms max.
(whichever is greater)
Contact Resistance Variation3.0 % or 3 ohms max.
(whichever is greater)
Adjustability
Voltage±0.02 %
Resistance±0.05 %
ResolutionInfinite
Insulation Resistance500 vdc.
1,000 megohms min.
Dielectric Strength
Sea Level600 vac
80,000 Feet250 vac
Effective Travel12 turns nom.

Environmental Characteristics

Power Rating (300 volts max.)
70 °C0.25 watt
150 °C0 watt
Temperature Range-55 °C to +150 °C
Temperature Coefficient±100 ppm/°C
Seal Test85 °C Fluorinert*
HumidityMIL-STD-202 Method 103
96 hours (2 % ΔTR, 10 Megohms IR)
Vibration30 G (1 % ΔTR; 1 % ΔVR)
Shock100 G (1 % ΔTR; 1 % ΔVR)
Load Life1,000 hours 0.25 watt 70 °C
(3 % ΔTR; 3 % CRV)
Rotational Life200 cycles
(4 % ΔTR; 3 % or 3 ohms,
whichever is greater, CRV)

Physical Characteristics

Torque3.0 oz-in. max.
Mechanical StopsWiper idles
TerminalsSolderable pins
Weight0.015 oz.
MarkingManufacturer's trademark, resistance code, wiring diagram, date code, manufacturer's model number and style
Wiper50 % (Actual TR) ±10 %
FlammabilityU.L. 94V-0
Standard Packaging50 pcs. per tube
Adjustment ToolH-90

*"Fluorinert" is a registered trademark of 3M Co.
*RoHS Directive 2002/95/EC Jan 27 2003 including Annex. Specifications are subject to change without notice.
Customers should verify actual device performance in their specific applications.
REV 09/04

Product Dimensions

3266W

Common Dimensions

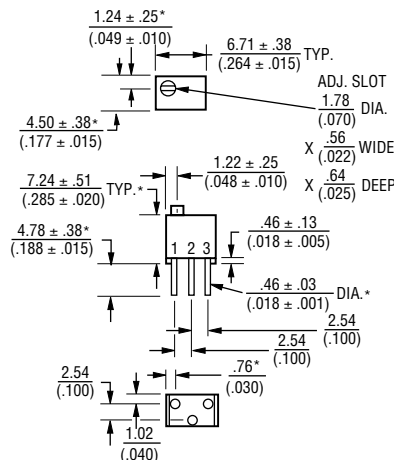

3266P

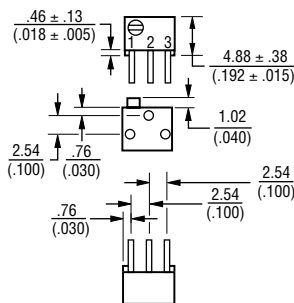

3266X

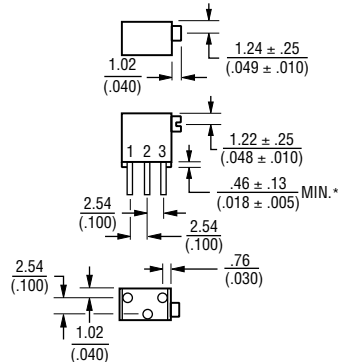

*Common dimensions

3266Y

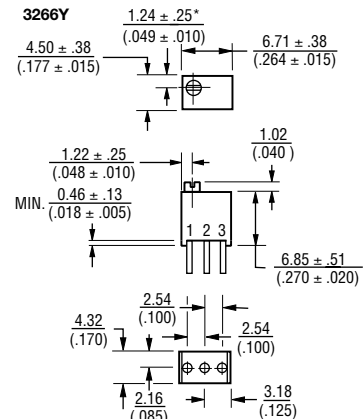

3266Z

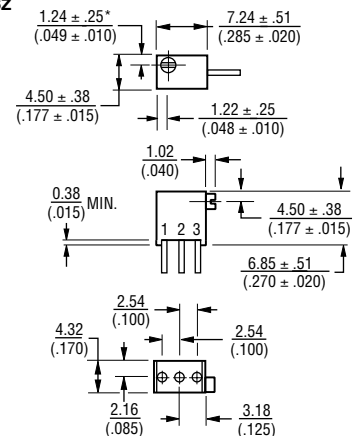

DIMENSIONS: MM/(INCHES)
TOLERANCES: ±.25/(±.010) EXCEPT WHERE NOTED

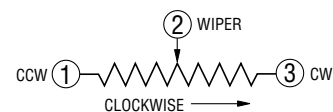

3266 – Ordering Information and Packaging Specifications

Standard Resistance Table

Resistance (Ohms)	Resistance Code
10	100
20	200
50	500
100	101
200	201
500	501
1,000	102
2,000	202
5,000	502
10,000	103
20,000	203
25,000	253
50,000	503
100,000	104
200,000	204
250,000	254
500,000	504
1,000,000	105

Popular distribution resistance values listed in **boldface**.
Special resistances available.

How To Order

3226 W - 1 - 103 LF

Model _____
 Style _____
 Standard or Modified Product Indicator _____
 -1 = Standard Product
 Resistance Code _____
 Packaging Designator _____
 Blank = Tube (Standard)
 R = Tape and Reel (Z and Y Pin Styles Only)
 A = Ammo Pack (Z and Y Pin Styles Only)
 Terminations _____
 LF = 100 % Tin-plated (RoHS compliant)
 Blank = 90 % Tin / 10 % Lead-plated (Standard)

Consult factory for other available options.

Packaging Specifications

SIDE ADJUST 3266Z-1

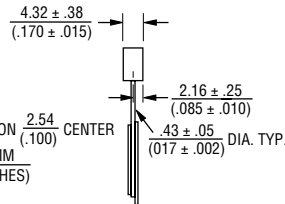
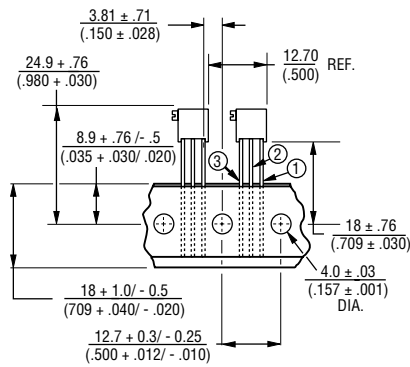

ALL PINS IN-LINE ON $\frac{2.54}{(.100)}$ CENTER
 DIMENSIONS: $\frac{MM}{(INCHES)}$
 1000/REEL/BOX

DIMENSIONS: MM/(INCHES)
 TOLERANCES: $\pm .25/(\pm .010)$ EXCEPT WHERE NOTED

Meets EIA Specification 468.

TOP ADJUST 3266Y-1

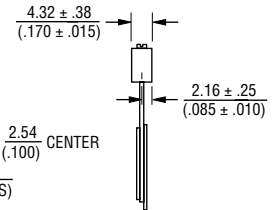
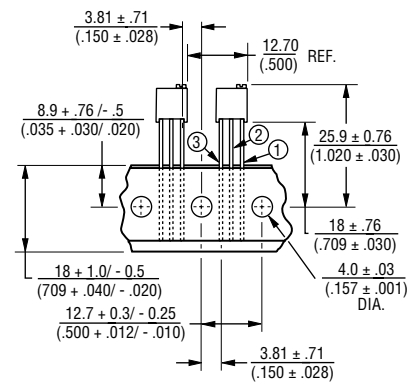

ALL PINS IN-LINE ON $\frac{2.54}{(.100)}$ CENTER
 DIMENSIONS: $\frac{MM}{(INCHES)}$
 1000/REEL/BOX

Meets EIA Specification 468.

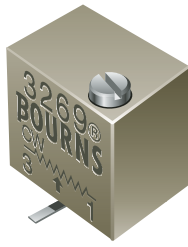

BOURNS®

3269 1/4" Square SMD Trimming Potentiometer

Features

- Stable, infinite resolution cermet element
- Vertical and horizontal adjust styles
- Optional packaging on embossed tape
- Compatible with surface mount manufacturing processes
- RoHS compliant[†] - see page 155 for processing information on lead free surface mount trimmers

Electrical Characteristics

Standard Resistance Range10 ohms to 1 megohm (see standard resistance table)
 Resistance Tolerance±10 % std. (closer tolerance available)
 Absolute Minimum Resistance1 % or 2 ohms max. (whichever is greater)
 Contact Resistance Variation3.0 % or 3 ohms max. (whichever is greater)
 Adjustability
 Voltage±0.02 %
 Resistance±0.05 %
 ResolutionInfinite
 Insulation Resistance500 vdc. 1,000 megohms min.
 Dielectric Strength
 Sea Level600 vac
 80,000 Feet250 vac
 Effective Travel12 turns nom.

Environmental Characteristics

Power Rating (300 volts max.)
 85 °C0.25 watt
 150 °C0 watt
 Temperature Range-65 °C to +150 °C
 Temperature Coefficient±100 ppm/°C
 Seal Test85 °C Fluorinert*
 HumidityMIL-STD-202 Method 106 (2 % ΔTR; IR 100 Megohms)
 Vibration30 G (1 % ΔTR; 1 % ΔVR)
 Shock100 G (1 % ΔTR; 1 % ΔVR)
 Load Life1,000 hours 0.25 watt @ 85 °C (3 % ΔTR; 3 % or 3 ohms whichever is greater, CRV)
 Rotational Life200 cycles (2 % ΔTR; 3 % or 3 ohms, whichever is greater, CRV)

Physical Characteristics

Torque3.0 oz-in. max.
 Mechanical StopsWiper idles
 TerminalsSolderable pins
 Weight0.015 oz.
 MarkingManufacturer's trademark, resistance code, wiring diagram, date code, manufacturer's model number and style
 Standard Packaging50 pcs. per tube
 Adjustment ToolH-90
 Wiper50 % (Actual TR) ±10 %

*"Fluorinert" is a registered trademark of 3M Co.
[†]RoHS Directive 2002/95/EC Jan 27 2003 including Annex. Specifications are subject to change without notice.
 Customers should verify actual device performance in their specific applications.
 REV 09/04

Product Dimensions

3269P

Common Dimensions

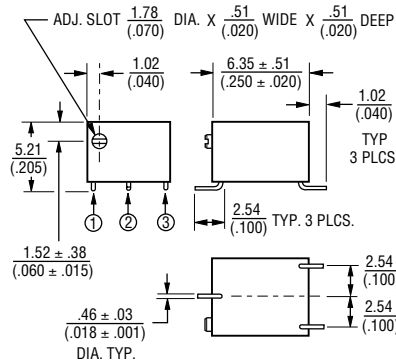

3269W

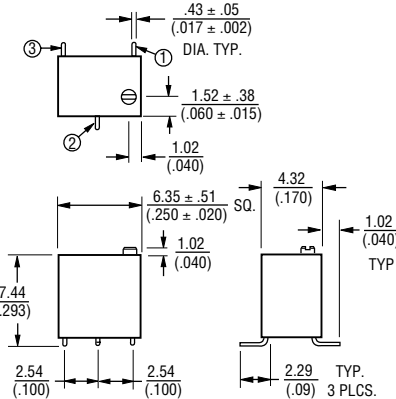

3269X

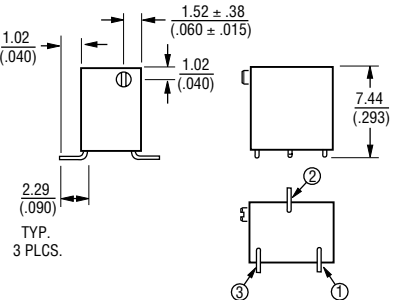

DIMENSIONS: MM/(INCHES)
 TOLERANCES: ±.25/(±.010) EXCEPT WHERE NOTED

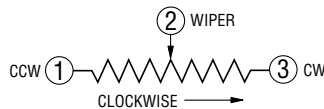

RECOMMENDED PCB LAYOUT - "P"

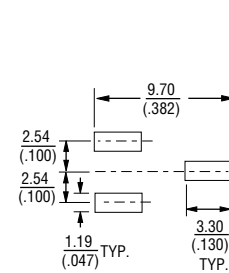

RECOMMENDED PCB LAYOUT - "W" & "X"

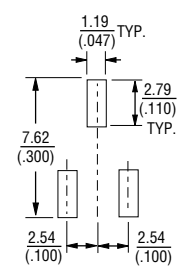

Standard Resistance Table

Resistance		Resistance	
Ohms	Code	Ohms	Code
10	100	10,000	103
20	200	20,000	203
50	500	25,000	253
100	101	50,000	503
200	201	100,000	104
500	501	200,000	204
1,000	102	250,000	254
2,000	202	500,000	504
5,000	502	1,000,000	105

Popular distribution resistance values listed in **boldface**. Special resistances available.

How To Order

3269 X - 1 - 103 G LF

Model _____
 Style _____
 Standard or Modified Product Indicator _____
 For P pin style:
 -1 = Terminals away from sprocket holes
 -2 = Terminals toward sprocket holes
 For W & X pin styles:
 -1 = Terminals toward sprocket holes
 -2 = Terminals away from sprocket holes
 For P, W & X pin styles:
 -11 = ±5 % TR
 Resistance Code _____
 Embossed Tape Designator _____
 G = Embossed Tape
 "P" Style - 750 pcs./13" reel
 "W, X" Style - 500 pcs./13" reel
 Terminations
 LF = 100 % Tin-plated (RoHS compliant)
 Blank = 90 % Tin / 10 % Lead-plated (Standard)

3269 – Packaging Specifications

P Style

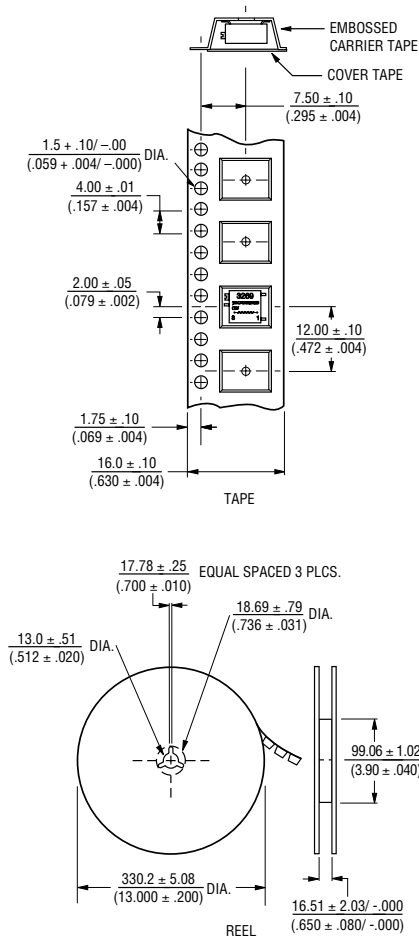

-1 Meets EIA Specification 481.
Units packaged 750 pieces per reel.

W and X Styles

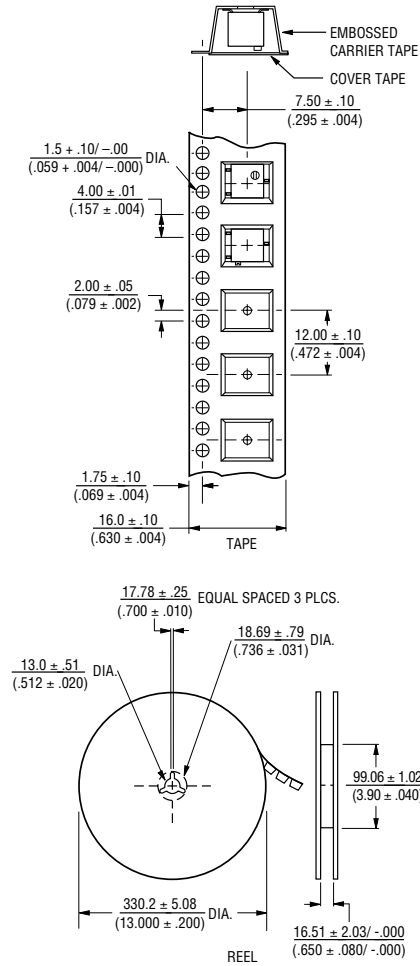

-2 Meets EIA Specification 481.
Units packaged 500 pieces per reel.

Specifications are subject to change without notice.
Customers should verify actual device performance in their specific applications.

AVAILABLE THROUGH DISTRIBUTION

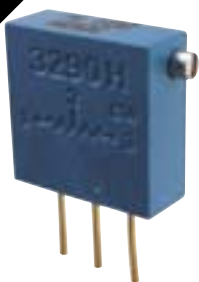

BOURNS®

3290 3/8" Square Trimming Potentiometer

Features

- Multiturn/ Wirewound / Industrial / Sealed
- Listed on the QPL for style RT24 per MIL-R-27208 and RTR24 per High-Rel MIL-R-39015
- Panel mount option available
- RoHS compliant†

Electrical Characteristics

Standard Resistance Range 10 to 50K ohms
 (see standard resistance table)
 Resistance Tolerance ±5 % std.
 (tighter tolerance available)
 Absolute Minimum Resistance 0.1 % or 1 ohm max.
 (whichever is greater)
 Noise 100 ohms ENR max.
 Resolution (see standard resistance table)
 Insulation Resistance 500 vdc.
 1,000 megohms min.
 Dielectric Strength
 Sea Level 1,000 vac
 80,000 Feet 350 vac
 Adjustment Travel 25 turns nom.

Environmental Characteristics

Power Rating @ 85 °C 1.0 watt
 Power Rating @ 150 °C 0 watt
 Temperature Range -65 °C to +150 °C
 Temperature Coefficient ±50 ppm/°C
 Seal Test 85 °C Fluorinert*
 Humidity MIL-STD-202 Method 106
 96 hours (2 % ΔTR; 100 Megohms IR)
 Vibration 30G
 (1 % ΔTR; 0.5 % + resolution ΔVR)
 Shock 100G
 (1 % ΔTR; 0.5 % + resolution ΔVR)
 Load Life 1,000 hours 1.0 watt @ 85 °C
 (2 % ΔTR; 500 ohms ENR)
 Rotational Life 200 cycles
 (2 % ΔTR; 500 ohms ENR)

Physical Characteristics

Torque 5.0 oz-in. max.
 Mechanical Stops Wiper idles
 Terminals Solderable printed circuit pins
 Weight 0.025 oz.
 Marking Manufacturer's trademark,
 resistance code, wiring diagram,
 date code, manufacturer's model
 number and style
 Wiper 50 % (Actual TR) ±10 %
 Flammability U.L. 94V-0
 Standard Packaging 50 pcs. per tube
 Adjustment Tool H-90

Product Dimensions

3290H

Common Dimensions

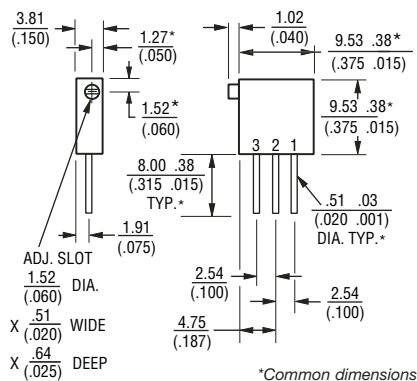

*Common dimensions

3290P

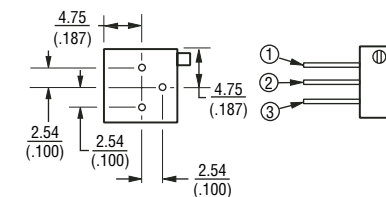

3290W

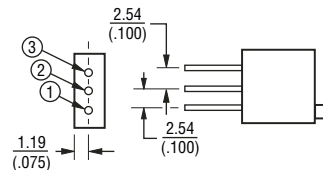

DIMENSIONS: MM/(INCHES)
 TOLERANCES: ±.25/(±.010) EXCEPT WHERE NOTED

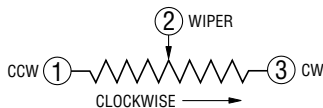

Standard Resistance Table

Resistance (Ohms)	Resistance Code	Nominal Resolution (Percent)
10	100	1.11
20	200	0.93
50	500	0.62
100	101	0.60
200	201	0.54
500	501	0.42
1,000	102	0.33
2,000	202	0.26
5,000	502	0.20
10,000	103	0.17
20,000	203	0.14
25,000	253	0.13
50,000	503	0.11

Popular distribution resistance values listed in **boldface**.
 Special resistances available.

How To Order

3290 H - 1 - 103 M

Model _____
 Style _____
 Standard or Modified _____
 Product Indicator _____
 -1 = Standard Product
 Resistance Code _____
 Optional Suffix Letter _____
 M = Panel Mount (Factory Installed)
 Consult factory for other available options.

†"Fluorinert" is a registered trademark of 3M Co.
 †RoHS Directive 2002/95/EC Jan 27 2003 including Annex.
 Specifications are subject to change without notice.
 Customers should verify actual device performance in
 their specific applications. REV 09/04

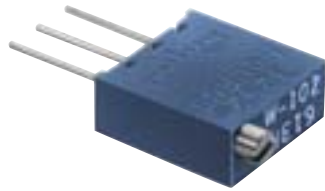

BOURNS®

3292 3/8" Square Trimming Potentiometer

Features

- Multiturn / Cermet / Industrial / Sealed
- Optional panel mount available
- Patent #4427966 drive mechanism
- Thin body profile
- RoHS compliant* version available

Electrical Characteristics

Standard Resistance Range10 to 1 megohm
 (see standard resistance table)
 Resistance Tolerance±10 % std.
 (tighter tolerance available)
 Absolute Minimum Resistance
 1 % or 2 ohms max. (whichever is greater)
 Contact Resistance Variation
 32921.0 % or 3 ohms max.
 (whichever is greater)
 Adjustability
 Voltage±0.01 %
 Resistance±0.05 %
 ResolutionInfinite
 Insulation Resistance500 vdc.
 1,000 megohms min.
 Dielectric Strength
 Sea Level900 vac
 80,000 Feet350 vac
 Effective Travel25 turns nom.

Environmental Characteristics

Power Rating (400 volts max.)
 85 °C0.5 watt
 150 °C0 watt
 Temperature Range-65 °C to +150 °C
 Temperature Coefficient±100 ppm/°C
 Seal Test...85 °C Fluorinert* (pin styles only)
 HumidityMIL-STD-202 Method 103
 96 hours (1 % ΔTR, 100 Megohms IR)
 Vibration30 G (1 % ΔTR; 1 % ΔVR)
 Shock100 G (1 % ΔTR; 1 % ΔVR)
 Load Life1,000 hours 0.5 watt @ 85 °C
 (2 % ΔTR; 3 % or 3 ohms,
 whichever is greater, CRV)
 Rotational Life200 cycles
 (2 % ΔTR; 3 % or 3 ohms,
 whichever is greater, CRV)

Physical Characteristics

Torque5.0 oz-in. max.
 Mechanical StopsWiper idles
 TerminalsSolderable printed circuit pins
 Weight0.025 oz.
 Machine Screw Mounting
 Torque12 oz-in. max.
 MarkingManufacturer's trademark,
 resistance code, wiring diagram,
 date code, manufacturer's
 model number and style
 Wiper50 % (Actual TR) ±10 %
 FlammabilityU.L. 94V-0
 Standard Packaging
 P, W & X Styles50 pcs. per tube
 L Style50 pcs. per bag
 Adjustment ToolH-90

Product Dimensions

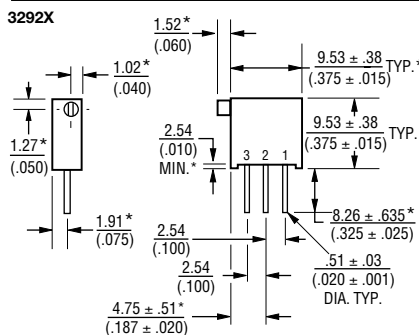
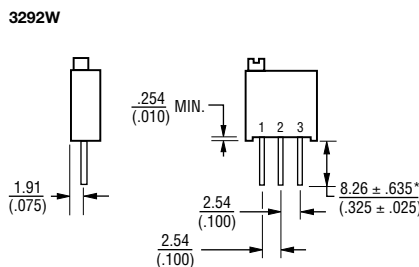
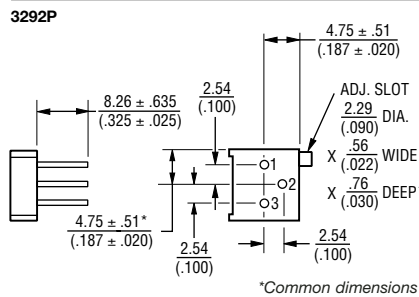
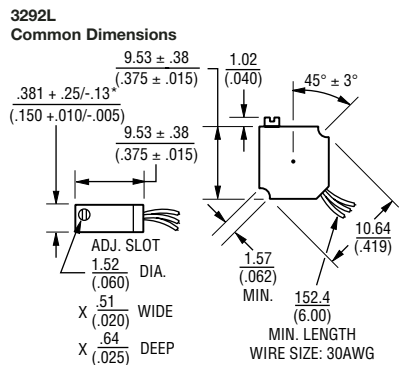

DIMENSIONS: MM/(INCHES)
 TOLERANCES: ±.25/(±.010) EXCEPT WHERE NOTED

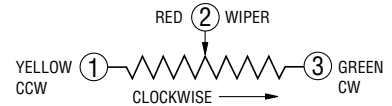

Standard Resistance Table

Resistance		Resistance	
Ohms	Code	Ohms	Code
10	100	10,000	103
20	200	20,000	203
50	500	25,000	253
100	101	50,000	503
200	201	100,000	104
500	501	200,000	204
1,000	102	250,000	254
2,000	202	500,000	504
5,000	502	1,000,000	105

Popular distribution resistance values listed in **boldface**. Special resistances available. Non-boldface items are typically not stocked by distributors and are not recommended for new designs.

How To Order

3292 W - 1 - 103 M LF

Model _____
 Style _____
 Standard or Modified Product Indicator
 -1 = Standard Product
 Resistance Code _____
 Optional Suffix Letter _____
 M = Panel Mount 3292L, W & X (Factory Installed)
 Terminations _____
 LF = 100 % Tin-plated (RoHS compliant)
 Blank = 90 % Tin / 10 % Lead-plated (Standard)
 Consult factory for other available options

*"Fluorinert" is a registered trademark of 3M Co.
 *RoHS Directive 2002/95/EC Jan 27 2003 including Annex. Specifications are subject to change without notice. Customers should verify actual device performance in their specific applications. REV 09/04

AVAILABLE THROUGH DISTRIBUTION

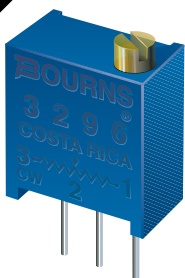

BOURNS®

3296 3/8" Square Trimming Potentiometer

Features

- Multiturn / Cermet / Industrial / Sealed
- 5 terminal styles
- Tape and reel packaging available
- Chevron seal design
- Listed on the QPL for style RJ24 per MIL-R-22097 and RJR24 per High-Rel Mil-R-39035
- Mounting hardware available (H-117P)
- RoHS compliant* version available

Electrical Characteristics

Standard Resistance Range
.....10 ohms to 2 megohms
(see standard resistance table)

Resistance Tolerance.....±10 % std.
(tighter tolerance available)

Absolute Minimum Resistance
.....1 % or 2 ohms max.
(whichever is greater)

Contact Resistance Variation
.....1.0 % or 3 ohms max.
(whichever is greater)

Adjustability
Voltage.....±0.01 %
Resistance.....±0.05 %

Resolution.....Infinite

Insulation Resistance.....500 vdc.
1,000 megohms min.

Dielectric Strength
Sea Level.....900 vac
70,000 Feet.....350 vac
Effective Travel.....25 turns nom.

Environmental Characteristics

Power Rating (300 volts max.)
70 °C.....0.5 watt
125 °C.....0 watt

Temperature Range.....-55 °C to +150 °C

Temperature Coefficient.....±100 ppm/°C

Seal Test.....85 °C Fluorinert*

Humidity.....MIL-STD-202 Method 103
96 hours (2 % ΔTR, 10 Megohms IR)

Vibration.....20 G (1 % ΔTR; 1 % ΔVR)

Shock.....100 G (1 % ΔTR; 1 % ΔVR)

Load Life.....1,000 hours 0.5 watt @ 70 °C
(3 % ΔTR; 3 % or 3 ohms, whichever is greater, CRV)

Rotational Life.....200 cycles
(4 % ΔTR; 3 % or 3 ohms, whichever is greater, CRV)

Physical Characteristics

Torque.....3.0 oz-in. max.

Mechanical Stops.....Wiper idles

Terminals.....Solderable pins

Weight.....0.03 oz.

Marking.....Manufacturer's trademark, resistance code, wiring diagram, date code, manufacturer's model number and style

Wiper.....50 % (Actual TR) ±10 %

Flammability.....U.L. 94V-0

Standard Packaging.....50 pcs. per tube

Adjustment Tool.....H-90

Product Dimensions

Common Dimensions

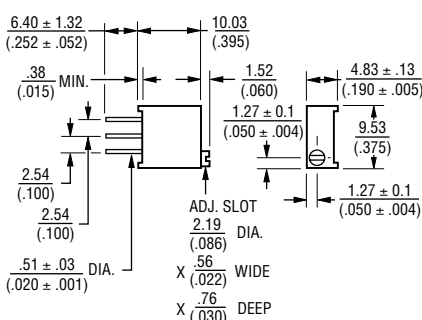

3296P

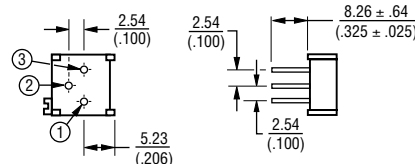

3296W

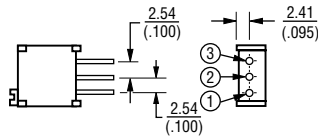

3296X

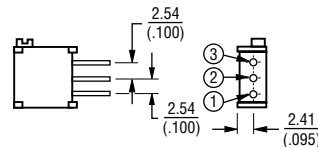

3296Y (Commercial Only)

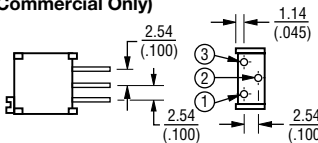

3296Z (Commercial Only)

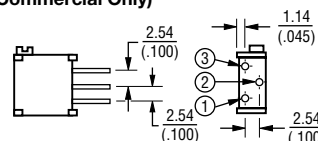

DIMENSIONS: MM/(INCHES)
TOLERANCES: ±.25/(±.010)
EXCEPT WHERE NOTED

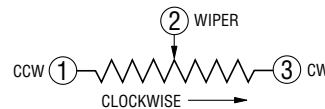

Standard Resistance Table

Resistance		Resistance	
Ohms	Code	Ohms	Code
10	100	20,000	203
20	200	25,000	253
50	500	50,000	503
100	101	100,000	104
200	201	200,000	204
500	501	250,000	254
1,000	102	500,000	504
2,000	202	1,000,000	105
5,000	502	2,000,000	205
10,000	103		

Popular distribution resistance values listed in **boldface**.
Special resistances available.

How To Order

3296 W - 1 - 103 LF

Model _____
Style _____
Standard or Modified Product Indicator _____
-1 = Standard Product
Resistance Code _____
Packaging Designator _____
Blank = Tube (Standard)
R = Tape and Reel (X and W Pin Styles Only)
A = Ammo Pack (X and W Pin Styles Only)

Terminations _____
LF = 100 % Tin-plated (RoHS compliant)
Blank = 90 % Tin / 10 % Lead-plated (Standard)

Consult factory for other available options.

*"Fluorinert" is a registered trademark of 3M Co.
*RoHS Directive 2002/95/EC Jan 27 2003 including Annex.
Specifications are subject to change without notice.
Customers should verify actual device performance in their specific applications. REV 09/04

3296 – Packaging Specifications

SIDE ADJUST 3296X-1

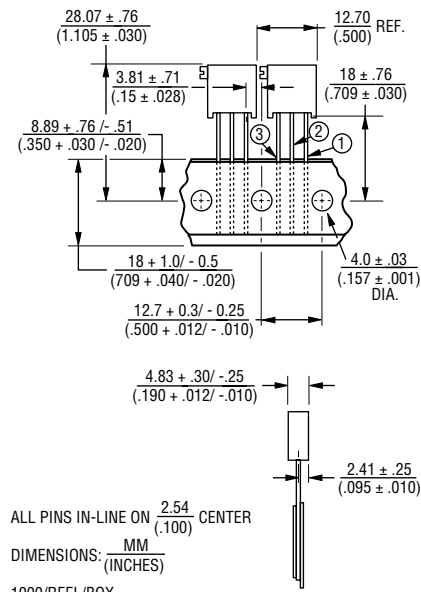

Meets EIA Specification 468.

TOP ADJUST 3296W-1

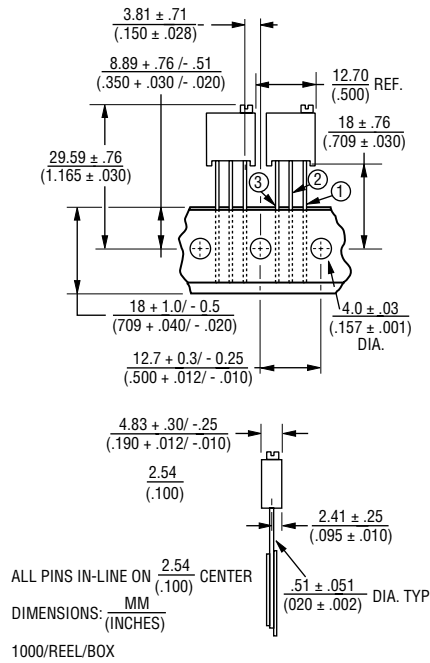

Meets EIA Specification 468.

Specifications are subject to change without notice.
 Customers should verify actual device performance in
 their specific applications.

3296-LC2

3/8" Square Trimming Potentiometer



BOURNS®

Features

- High Performance Series 3/8" Square / Multiturn / Cermet / Industrial / Sealed
- Thin body profile
- Sealed to withstand board washing processes
- Patent #4427966, #4732802, #4824694
- Low current applications <50 uA
- Mounting hardware available
- RoHS compliant* version available

Electrical Characteristics

Standard Resistance Range500 ohms to 100K ohms
 (see standard resistance table)
 Resistance Tolerance±10 % std.
 Absolute Minimum Resistance2 ohms or 1 % max.
 (whichever is greater)
 Contact Resistance Variation ...0.5 % max.
 Contact Resistance (D.C. mode)0.3 % max.
 D.C. Offset0.5 % max.
 Adjustability
 Voltage±0.1 %
 Resistance±0.2 %
 Insulation Resistance500 vdc.
 1,000 megohms min.
 Dielectric Strength
 Sea Level900 vac
 70,000 feet350 vac
 Adjustment Angle, Electrical25 ±5 turns

Environmental Characteristics

Power Rating (400 volts max.)
 85 °C0.5 watt
 125 °C0 watt
 Temperature Range.....-55 °C to +125 °C
 Temperature Coefficient±100 ppm/°C
 Humidity80-90 %, RH, 10 cycles
 2 % max. TRS, IR 10 megohms
 0.2 % max. contact resistance shift
 Seal Test85 °C Fluorinert*
 Vibration20 G - 0.5 % VRS
 0.2 % contact resistance shift
 Shock100 G - 0.5 % VRS
 0.2 % contact resistance shift
 Load Life @ 85 °C Rated Power
1,000 hours 3 % TRS,
 0.2 % contact resistance
 shift - 0.5 % CRV
 Rotational Life200 cycles, 4 % TRS
 0.2 % contact resistance shift
 Thermal Shock5 cycles
 2 % TRS, 0.5 % VRS
 0.2 % contact resistance shift

Physical Characteristics

Torque3.0 oz-in. max.
 Mechanical StopsWiper idles
 TerminalsSolderable PC pins
 Weight0.03 oz.
 MarkingManufacturer's trademark,
 resistance code and date code
 Wiper50 % (Actual TR) ±10 %
 FlammabilityU.L. 94V-0
 Standard Packaging50 pcs. per tube
 Adjustment ToolH-90

Product Dimensions

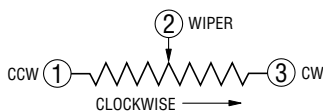
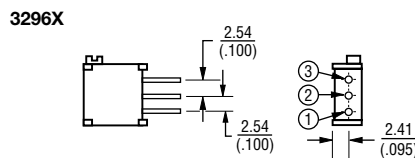
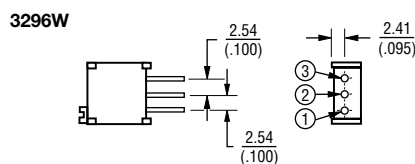
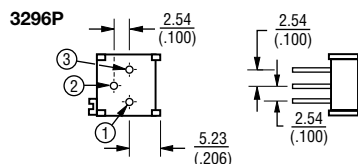
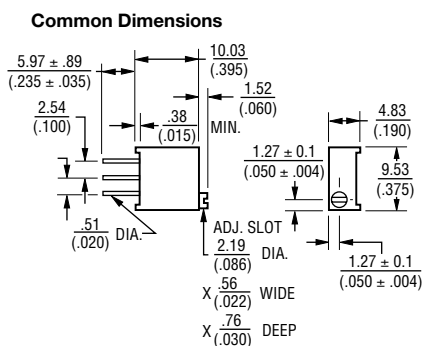

DIMENSIONS: MM/(INCHES)
 TOLERANCES: ±.25/(±.010) EXCEPT WHERE NOTED

Standard Resistance Table

Resistance (Ohms)	Resistance Code
500	501
1,000	102
2,000	202
5,000	502
10,000	103
20,000	203
25,000	253
50,000	503
100,000	104

Popular distribution resistance values listed in **boldface**. Special resistances available. Non-boldface items are typically not stocked by distributors and are not recommended for new designs.

How To Order

3296 W - LC2 - 103 LF

Model _____
 Style _____
 Product Indicator _____
 Resistance Code _____
 Terminations _____
 LF = 100 % Tin-plated (RoHS compliant)
 Blank = 90 % Tin / 10 % Lead-plated (Standard)

Consult factory for other available options.

*"Fluorinert" is a registered trademark of 3M Co.
 †RoHS Directive 2002/95/EC Jan 27 2003 including Annex. Specifications are subject to change without notice. Customers should verify actual device performance in their specific applications. REV 09/04

3296-OT1

3/8" Square Trimming Potentiometer

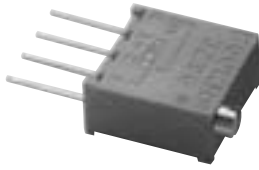

BOURNS®

Features

- 3/8" Square/ Multiturn / Cermet Industrial / Sealed
- Designed for operational amplifier offset voltage adjustment applications
- Reduces power supply drift errors
- Unique center tapped trimming potentiometer
- Vertical and horizontal adjust types available
- Patent #4427966 drive mechanism
- Mounting hardware available
- RoHS compliant* version available

Electrical Characteristics

Standard Resistance Range
(Pin 1 to Pin 3) ...100 ohms to 1 megohm
(see standard resistance table)
Resistance Tolerance±20 % std.
Absolute Minimum Resistance
.....2 ohms max.
Voltage Output Variation+0.25 %
Adjustability (VR)±0.025 %
Insulation Resistance500 vdc.
1,000 megohms min.
Dielectric Strength
Sea Level900 vac
70,000 Feet350 vac
Effective Electrical Travel, Nom.25 turns
Center Tap Resistance2 ohms max.
Center Tap Electrical Center±5 %
Center Tap Dead Band0.5 turn

Environmental Characteristics

Power Rating
70 °C0.5 watt
125 °C0 watt
Temperature Range-55 °C to +125 °C
Temperature Stability (ΔVR)±0.5 % max.
Seal Test85 °C Fluorinert*
HumidityMIL-STD-202 Method 103
96 hours10 megohms min.
Vibration, 20 G±1 % ΔTR
Shock, 100 G±1 % ΔTR
Load Life, 1,000 Hours±3 % ΔTR
Rotational Life, 200 cycles±4 % ΔTR

Physical Characteristics

Torque3.0 oz-in. max.
Mechanical StopsWiper idles
TerminalsSolderable pins
Weight0.03 oz.
MarkingManufacturer's trademark,
resistance code, wiring diagram,
date code, manufacturer's model
number and style
FlammabilityU.L. 94V-0
Standard Packaging
.....50 pcs. per tube/tray
Adjustment ToolH-90

Also see Model 3386-OT1.

*"Fluorinert" is a registered trademark of 3M Co.
*RoHS Directive 2002/95/EC Jan 27 2003 including Annex.
Specifications are subject to change without notice.
Customers should verify actual device performance in
their specific applications. REV 09/04

Product Dimensions

Common Dimensions

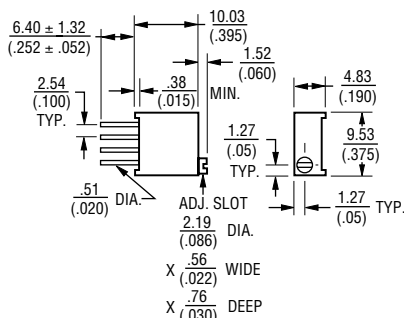

3296W-OT1

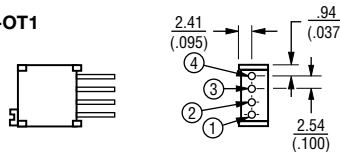

3296X-OT1

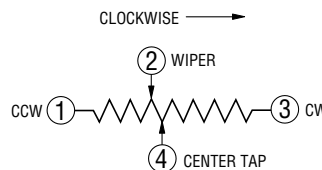
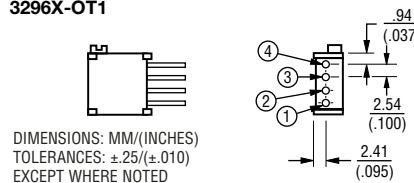

Suggested Offset Voltage Adjustment Circuit

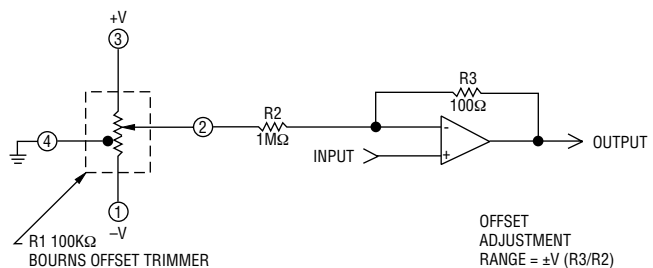

Standard Resistance Table

Resistance (Ohms)	Resistance Code
100	101
200	201
500	501
1,000	102
2,000	202
5,000	502
10,000	103
20,000	203
50,000	503
100,000	104
200,000	204
500,000	504
1,000,000	105

Popular distribution resistance values listed in **boldface**. Special resistances available. Non-boldface items are typically not stocked by distributors and are not recommended for new designs.

How To Order

3296 X - OT1 - 103 LF

Model _____
Style _____
Catalog Product _____
Resistance Code _____
Terminations
LF = 100 % Tin-plated (RoHS compliant)
Blank = 90 % Tin / 10 % Lead-plated (Standard)

AVAILABLE THROUGH DISTRIBUTION



BOURNS®

3299 3/8" Square Trimming Potentiometer

Features

- 3/8" Square / Multiturn / Cermet / Industrial / Sealed
- Five popular terminal styles
- Standoffs
- Patent #4427966 drive mechanism
- RoHS compliant* version available

Electrical Characteristics

Standard Resistance Range10 to 2 megohms
 (see standard resistance table)
 Resistance Tolerance±10 % std.
 (tighter tolerance available)
 Absolute Minimum Resistance
1 % or 2 ohms max.
 (whichever is greater)
 Contact Resistance Variation
1.0 % or 3 ohms max.
 (whichever is greater)
 Adjustability
 Voltage±0.01 %
 Resistance±0.05 %
 ResolutionInfinite
 Insulation Resistance500 vdc.
 1,000 megohms min.
 Dielectric Strength
 Sea Level900 vac
 70,000 Feet350 vac
 Effective Travel25 turns nom.

Environmental Characteristics

Power Rating (300 volts max.)
 70 °C0.5 watt
 125 °C0 watt
 Temperature Range-55 °C to +125 °C
 Temperature Coefficient±100 ppm/°C
 Seal Test85 °C Fluorinert*
 HumidityMIL-STD-202 Method 103
 96 hours (2 % ΔTR, 10 Megohms IR)
 Vibration20 G (1 % ΔTR; 1 % ΔVR)
 Shock100 G (1 % ΔTR; 1 % ΔVR)
 Load Life1,000 hours 0.5 watt @ 70 °C
 (3 % ΔTR; 3 % or 3 ohms,
 whichever is greater, CRV)
 Rotational Life200 cycles
 (4 % ΔTR; 3 % or 3 ohms,
 whichever is greater, CRV)

Physical Characteristics

Torque3.0 oz-in. max.
 Mechanical StopsWiper idles
 TerminalsSolderable pins
 Weight0.035 oz.
 MarkingManufacturer's trademark,
 resistance code, wiring diagram,
 date code, manufacturer's model
 number and style
 Wiper50 % (Actual TR) ±10 %
 FlammabilityU.L. 94V-0
 Standard Packaging50 pcs. per tube
 Adjustment ToolH-90

Product Dimensions

3299P

Common Dimensions

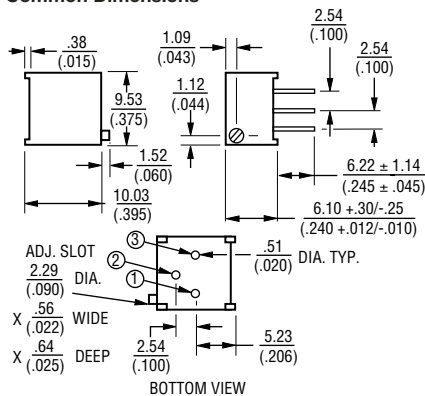

3299W

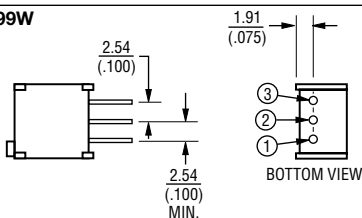

3299X

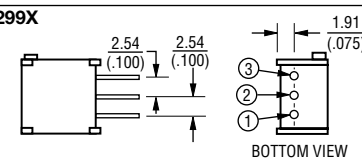

3299Y

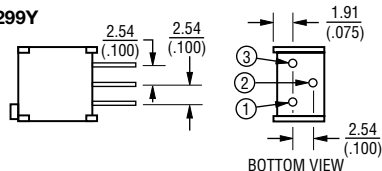

3299Z

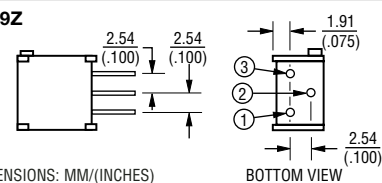

DIMENSIONS: MM/(INCHES)
 TOLERANCES: ±.25/(±.010)
 EXCEPT WHERE NOTED

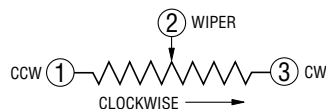

Standard Resistance Table

Resistance		Resistance	
Ohms	Code	Ohms	Code
10	100	20,000	203
20	200	25,000	253
50	500	50,000	503
100	101	100,000	104
200	201	200,000	204
500	501	250,000	254
1,000	102	500,000	504
2,000	202	1,000,000	105
5,000	502	2,000,000	205
10,000	103		

Popular distribution resistance values listed in **boldface**.
 Special resistances available.

How To Order

Model 3299 W - 1 - 103 LF
 Style _____
 Standard or Modified
 Product Indicator _____
 -1 = Standard Product
 Resistance Code _____
 Terminations _____
 LF = 100 % Tin-plated (RoHS compliant)
 Blank = 90 % Tin / 10 % Lead-plated
 (Standard)
 Consult factory for other available options.

*"Fluorinert" is a registered trademark of 3M Co.
 *RoHS Directive 2002/95/EC Jan 27 2003 including Annex.
 Specifications are subject to change without notice.
 Customers should verify actual device performance in
 their specific applications. REV 09/04

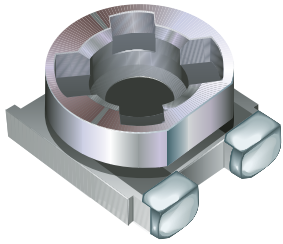

BOURNS®

3302 2 mm SMD Trimming Potentiometer

Features

- Single-Turn Cermet / Open Frame
- Recommended for reflow processing
- Rotor design compatible with automatic adjustment equipment
- Supplied in 8 mm embossed tape, compatible with automatic assembly equipment
- 2 mm size meets EIA/EIAJ standard trimmer footprint
- RoHS compliant* – See page 155 for processing information on lead free surface mount trimmers

Electrical Characteristics

Standard Resistance Range200 to 1 megohm
 (see standard resistance table)
 Resistance Tolerance±25 % std.
 Absolute Minimum Resistance
 ≤1K20 ohms max.
 >1K5 % max.
 Contact Resistance Variation
5 % max.
 ResolutionInfinite
 Adjustment Angle260 ° ±20 °

Environmental Characteristics

Power Rating (50 VDC max.)
 70 °C0.15 watt
 Temperature Range.....-40 °C to +85 °C
 Temperature Coefficient.....±250 ppm/°C
 Humidity95 % RH (500 hours)
 TRS max.±5 %
 Load Life....@ 70 °C rated power 500 hours
 TRS ±5 %
 Rotational Cycling.....10 turns
 TRS ±15 %

Physical Characteristics

Torque10-150 g-cm max.
 Mechanical AngleContinuous
 Marking.....Part marking code
 Standard Packaging.....2000 pcs./7" reel
 Adjustment ToolH-91

Standard Resistance Table

Resistance (Ohms)	Part Marking Code	Resistance Code
200	22	201
500	52	501
1,000	13	102
2,000	23	202
5,000	53	502
10,000	14	103
20,000	24	203
50,000	54	503
100,000	15	104
200,000	25	204
500,000	55	504
1,000,000	16	105

Popular distribution resistance values listed in **boldface**.
 Special resistances available.

Product Dimensions

3302W, X-3
3 Terminals for
Automatic Trimming Adjustment
Low Profile

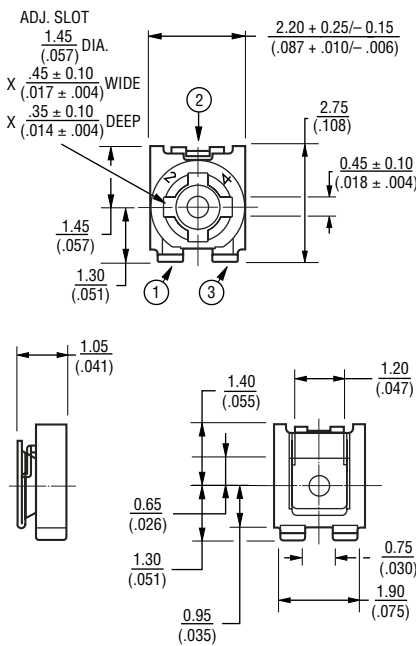

SUGGESTED PWB LAYOUT

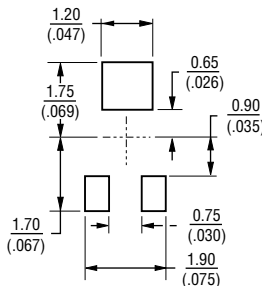

DIMENSIONS: MM/(INCHES)
 TOLERANCES: ±.25/(±.010) EXCEPT WHERE NOTED

Specifications are subject to change without notice.
 *RoHS Directive 2002/95/EC Jan 27 2003 including Annex.
 Customers should verify actual device performance in their specific applications.
 REV 09/04

Packaging Specifications

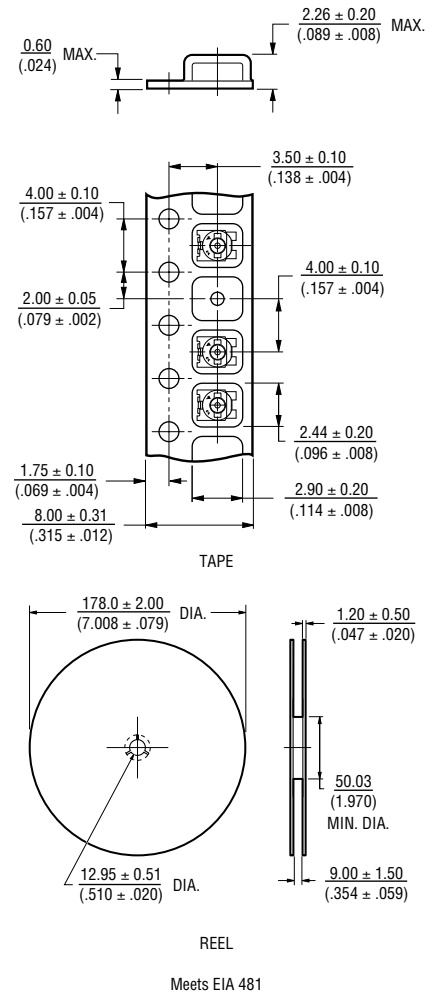

How To Order

3302 X - 3 - 103 E

Model _____
 Style _____
 Orientation of Parts in Tape
 Style W = Terminals Toward Sprocket Holes
 Standard or Modified
 Product Indicator
 -3 = Continuous Rotation
 Resistance Code _____
 Embossed Tape Designator _____
 Consult factory for other available options.

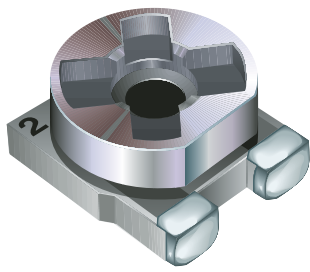

BOURNS®

3303 3 mm SMD Trimming Potentiometer

Features

- Recommended for reflow processing
- Rotor design compatible with pick and place and automatic adjustment equipment
- Supplied in 8 mm embossed tape, compatible with automatic assembly equipment
- Rear adjust version available
- 3 mm size meets EIA/EIAJ standard trimmer footprint
- RoHS compliant* – See page 155 for processing information on lead free surface mount trimmers

Electrical Characteristics

Standard Resistance Range
100 ohms to 1 megohm
 (see standard resistance table)
 Resistance Tolerance±25 % std.
 Absolute Minimum Resistance
 ≤ 1K Ohms20 ohms max.
 >1K Ohms2 % max. of TR
 Contact Resistance Variation5 % max.
 ResolutionInfinite
 Adjustment Angle260 ° ±20 °

Environmental Characteristics

Resistance to Soldering Heat
260 °C, 10 seconds, TRS max. 5 %
 Power Rating (50 VDC max.)
 70 °C0.15 watt
 Temperature Range.....-40 °C to +125 °C
 Temperature Coefficient±250 ppm/°C
 Humidity95 % RH (500 hours)
 TRS max.±5 %
 Load Life....@ 70 °C rated power 500 hours
 TRS ± 5 %
 Rotational Cycling.....20 turns
 TRS ± 15 %

Physical Characteristics

Torque20-200 g-cm max.
 Mechanical AngleContinuous
 Marking.....Part marking code
 Standard Packaging.....2000 pcs./7 " reel
 Adjustment ToolH-90

Product Dimensions

3303W, X-3
3 mm Open Frame
for Reflow Soldering
3-Terminal
Low Profile

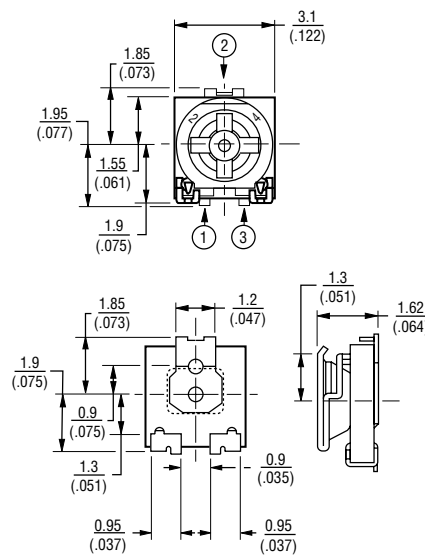

SUGGESTED PWB LAYOUT

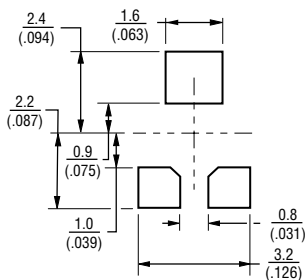

DIMENSIONS: MM/(INCHES)
 TOLERANCES: ±.30/(±.012) EXCEPT WHERE NOTED

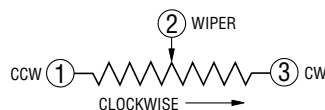

3303C,D-1
3-Terminal
Both Sides Adjust
(OPTIONAL)

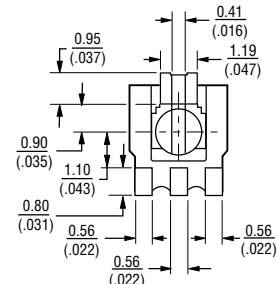
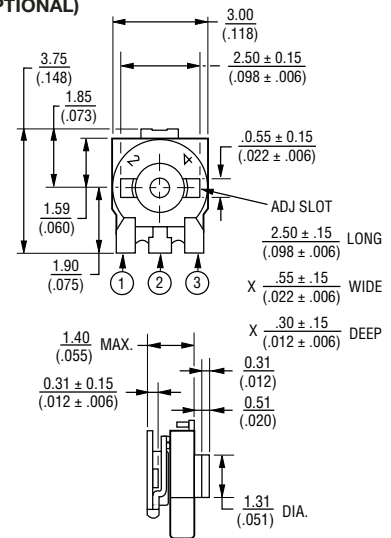

SUGGESTED PWB LAYOUT

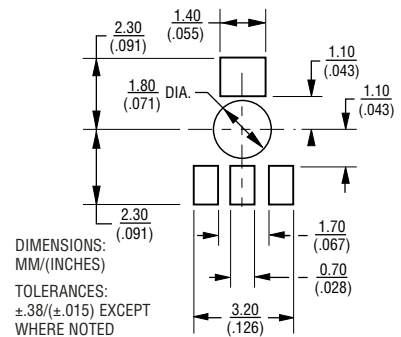

Specifications are subject to change without notice.
 *RoHS Directive 2002/95/EC Jan 27 2003 Including Annex.
 Customers should verify actual device performance in their specific applications.
 REV 09/04

3303 – Ordering Information and Packaging Specifications

Packaging Specifications

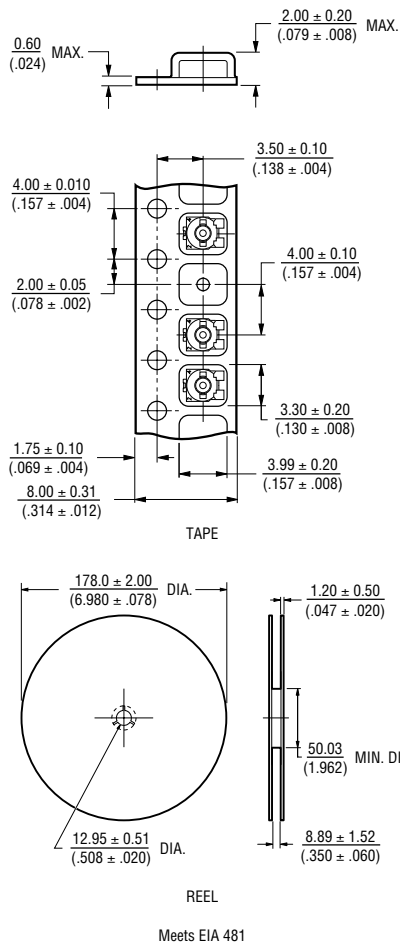

DIMENSIONS: MM/(INCHES)
TOLERANCES: ±.25/(±.010) EXCEPT WHERE NOTED

Standard Resistance Table

Resistance (Ohms)	Part Marking Code	Resistance Code
100	12	101
200	22	201
500	52	501
1,000	13	102
2,000	23	202
5,000	53	502
10,000	14	103
20,000	24	203
50,000	54	503
100,000	15	104
200,000	25	204
500,000	55	504
1,000,000	16	105

Popular distribution resistance values listed in **boldface**.
Special resistances available.

How To Order

Model 3303 X - 3 - 103 E

Style _____

Orientation of Parts in Tape

- Styles W & C
Terminals Toward Sprocket Holes
- Styles X & D
Terminals Away from Sprocket Holes (preferred)

Standard or Modified Product Indicator _____

-1 = Single Slot
-3 = Cross Slot Low Profile* (Standard)

Resistance Code _____

Embossed Tape Designator _____

Consult factory for other available options.

*Not available in C and D styles.

Specifications are subject to change without notice.
Customers should verify actual device performance in their specific applications.

AVAILABLE THROUGH DISTRIBUTION

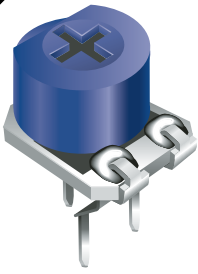

BOURNS®

3306 6 mm Round Trimming Potentiometer

Features

- 6 mm Round / Single-Turn / Cermet Industrial / Open Frame
- Cross slot adjustment options
- Horizontal and vertical mounting styles
- Dust resistant/splash resistant covers
- PC board stand-offs and retention feature
- Front and top adjust styles
- RoHS compliant*

Electrical Characteristics

Standard Resistance Range100 ohms to 1 megohm
(see standard resistance table)
Resistance Tolerance±25 % std.
(tighter tolerance available)
Absolute Minimum Resistance2 % max. (≤2K = 30 ohms)
Contact Resistance Variation3 % max.
Resolution.....Essentially infinite
Adjustment Angle.....215 ° nom.

Environmental Characteristics

Power Rating (100 volts max.)
70 °C0.2 watt
Temperature Range.....-25 °C to +100 °C
Temperature Coefficient±250 ppm/°C
Load Life.....1,000 hours 0.2 watt @ 70 °C
(5 % ΔTR)

Physical Characteristics

Mechanical Angle260 ° ±20 °
Torque (Operating)4.5 oz-in. max.
Stop Strength.....6.5 oz-in. min.
TerminalsSolderable pins
MarkingManufacturer's trademark, resistance code
Standard Packaging300 pcs. per bag
Adjustment ToolH-90
Aqueous cleaning not recommended

Standard Resistance Table

Resistance		Resistance	
Ohms	Code	Ohms	Code
100	101	25,000	253
200	201	50,000	503
500	501	100,000	104
1,000	102	200,000	204
2,000	202	250,000	254
5,000	502	500,000	504
10,000	103	1,000,000	105
20,000	203		

Popular distribution resistance values listed in **boldface**.
Special resistances available.

How To Order

Model 3306 W - 1 - 103
Style _____
Standard Product _____
Resistance Code _____

Product Dimensions

Top Adjust Common Dimensions

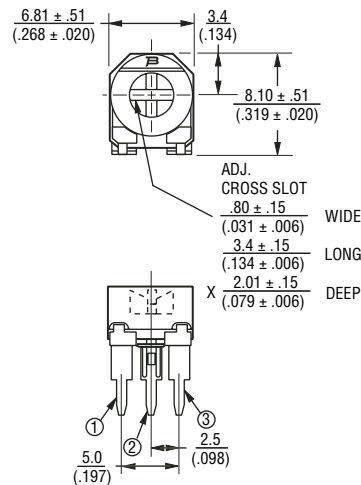

3306P

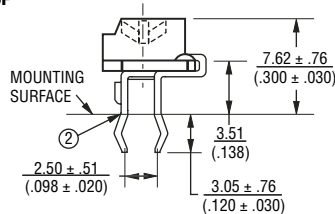

3306F

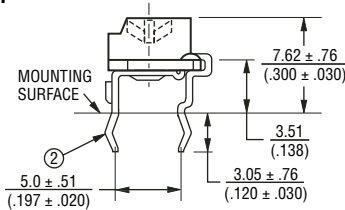

SUGGESTED PWB LAYOUT - STYLE F

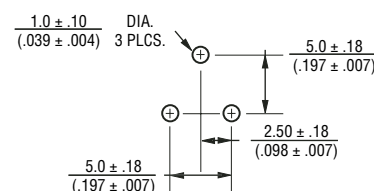

DIMENSIONS: MM/(INCHES)
TOLERANCES: ±.25/(±.010) EXCEPT WHERE NOTED

Side Adjust Common Dimensions

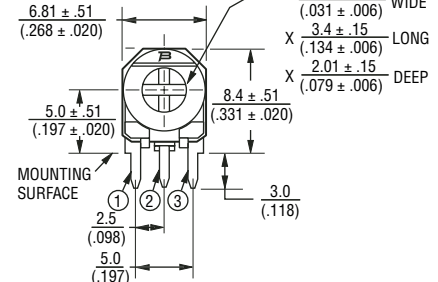

3306W

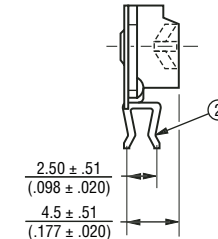

3306K

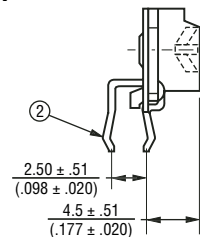

SUGGESTED PWB LAYOUT - STYLES K, P, W

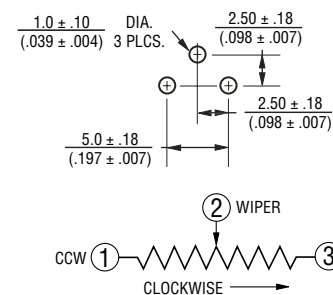

Specifications are subject to change without notice.
*RoHS Directive 2002/95/EC Jan 27 2003 including Annex.
Customers should verify actual device performance in their specific applications. REV 09/04

AVAILABLE THROUGH DISTRIBUTION



BOURNS®

3309 9 mm Round Trimming Potentiometer

Features

- 9 mm Round / Single-Turn / Cermet / Industrial / Open Frame
- Both sides adjust
- Cross slot and hexagon adjustment designs
- Horizontal and vertical mounting styles
- Dust resistant/ splash resistant covers
- PC board stand-offs and retention feature
- RoHS compliant*

Electrical Characteristics

Standard Resistance Range100 ohms to 2 megohms
 (see standard resistance table)
 Resistance Tolerance±25 % std.
 (tighter tolerance available)
 Absolute Minimum Resistance2 % max. (≤2K = 30 ohms)
 Contact Resistance Variation3 % max.
 Resolution.....Essentially infinite
 Adjustment Angle235 ° nom.

Environmental Characteristics

Power Rating (250 volts max.)
 70 °C0.5 watt
 Temperature Range.....-25 °C to +100 °C
 Temperature Coefficient±250 ppm/°C
 Load Life1,000 hours 0.5 watt
 @ 70 °C (5 % ΔTR)

Physical Characteristics

Mechanical Angle260 °±10 °
 Torque (Operating)5 oz-in. max.
 Stop Strength.....11.0 oz -in. min.
 TerminalsSolderable pins
 MarkingManufacturer's trademark, resistance code
 Standard Packaging200 pcs. per bag
 Adjustment ToolH-90
 Aqueous cleaning not recommended

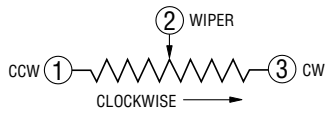

Top/Bottom Adjust Common Dimensions 3309P

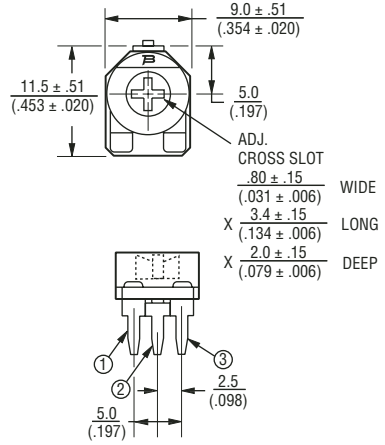

3309P-1 Top Adjust

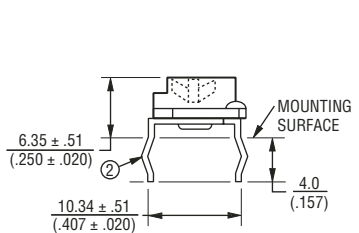

3309P-2 Both Sides Adjust/Cross Slot

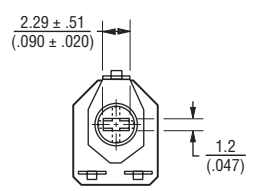
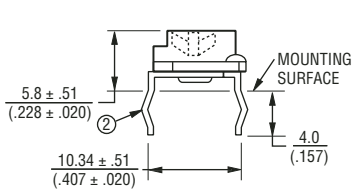

3309P-3 Both Sides Adjust Hex

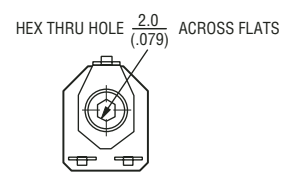
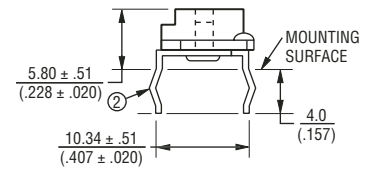
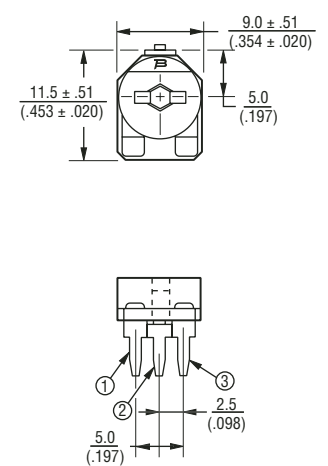

SUGGESTED PWB LAYOUT - 3309P

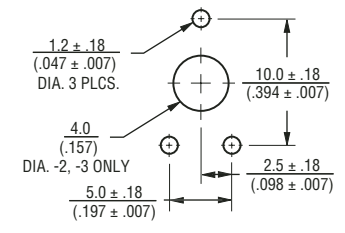

DIMENSIONS: MM/(INCHES)
 TOLERANCES: ±.25/(±.010) EXCEPT WHERE NOTED

Specifications are subject to change without notice.
 *RoHS Directive 2002/95/EC Jan 27 2003 Including Annex.
 Customers should verify actual device performance in their specific applications. REV 09/04

Trimmer Data Sheets

3309 – Ordering Information and Packaging Specifications

Packaging Specifications

Side Adjust Common Dimensions 3309W

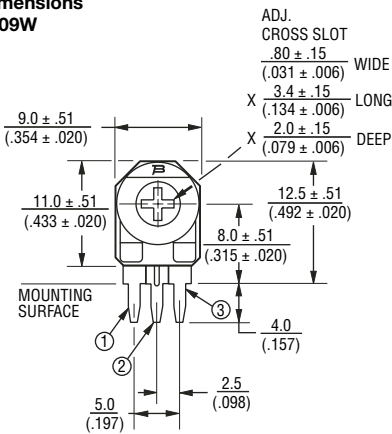

3309W-1 Single Side (Front) Adjust

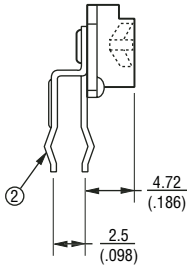

3309W-2 Both Sides Adjust - Cross Slot

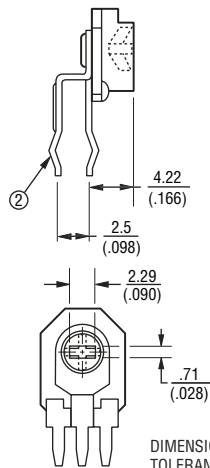

3309W-3 Both Sides Adjust Hex

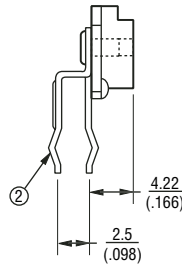
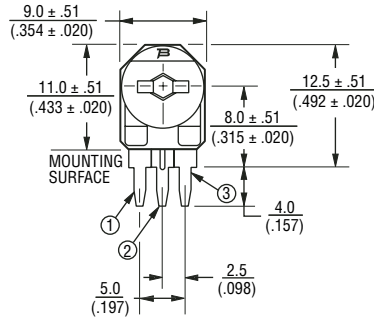

HEX THRU HOLE $\frac{2.01}{(.079)}$ ACROSS FLATS

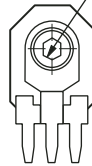

SUGGESTED PWB LAYOUT - 3309W

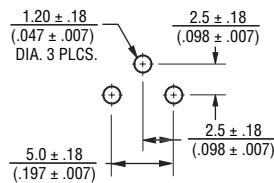

Standard Resistance Table

Resistance		Resistance	
Ohms	Code	Ohms	Code
100	101	25,000	253
200	201	50,000	503
500	501	100,000	104
1,000	102	200,000	204
2,000	202	250,000	254
5,000	502	500,000	504
10,000	103	1,000,000	105
20,000	203	2,000,000	205

Popular distribution resistance values listed in **boldface**.
Special resistances available.

How To Order

Model 3309 W - 2 - 103
 Style _____
 Rotor Style _____
 -2 = Cross Slot/Single Slot Rear Adjust
 -3 = 2 mm Hex Thru Hole
 Resistance Code _____

Specifications are subject to change without notice.
Customers should verify actual device performance in their specific applications.

AVAILABLE THROUGH DISTRIBUTION

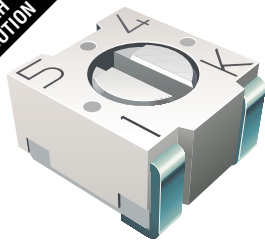

BOURNS®

3313 3 mm Trimming Potentiometer

Features

- Surface Mount 3 mm Square Single-Turn / Cermet / Sealed
- Compatible with surface mount manufacturing processes
- Rotor stop for "in-circuit" adjustment
- 100 cycle rotational and seal life
- RoHS compliant* – See page 155 for processing information on lead free surface mount trimmers

Electrical Characteristics

Standard Resistance Range10 ohms to 2 megohms (see standard resistance table)
 Resistance Tolerance±20 % std.
 End Resistance1 % or 3 ohms max. (whichever is greater)
 Contact Resistance Variation3 % or 3 ohms
 Adjustability
 Voltage Divider±0.1 %
 Rheostat±0.2 %
 ResolutionInfinite
 Insulation Resistance500 vdc. 100 megohms min.
 Dielectric Strength
 Sea Level500 vac
 70,000 Feet350 vac
 Adjustment Angle220 ° nom.

Environmental Characteristics

Max. Soldering Exposure260 °C/5 seconds
 Power Rating (200 volts max.)
 70 °C0.125 watt
 125 °C0 watt
 Operating Temp. Range-55 °C to +125 °C
 Temperature Coefficient
≤100 ohms ±150 ppm/°C;
 >100 ohms ±100 ppm/°C
 Seal Test85 °C Fluorinert*
 HumidityMIL-STD 202, Method 106 (no vibration) TRS ±3 %; IR 10 megohms
 Vibration20 G TRS ±1 %; VRS ±1 %
 Shock100 G TRS ±1 %; VRS ±1 %
 Load Life1000 hours @ 70 °C Rated Power; TRS ±3 %
 Rotational Life100 cycles TRS ±3 %
 Thermal Shock5 cycles TRS ±2 %; VRS ±1 %

Physical Characteristics

Mechanical Angle250 ° nom.
 Torque50 g-cm max.
 Stop Strength200 g-cm min.
 Pushover Strength ("S" only)1.6 Kilograms (3.5 lbs) minimum
 FlammabilityU.L. 94V-0
 WeightApprox. 0.01 oz.
 MarkingResistance code and date code
 Wiper50 % (Actual TR) ±10 %
 Standard Packaging1000 pcs./7 " reel
 Adjustment ToolH-91

Product Dimensions

3313J

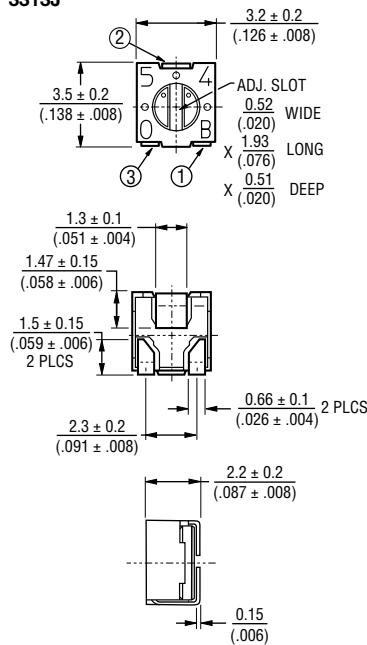

RECOMMENDED LAND PATTERN

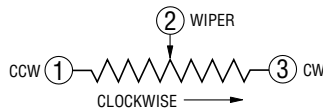
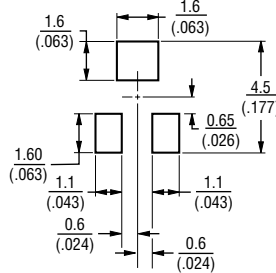

3313S

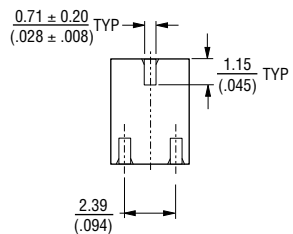
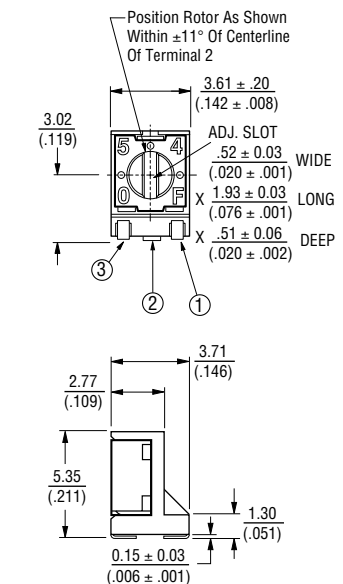

RECOMMENDED LAND PATTERN

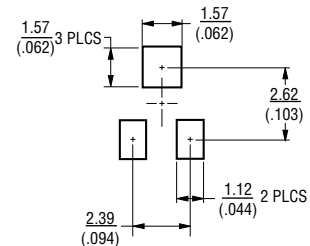

DIMENSIONS: MM/(INCHES)
 TOLERANCES: ±.25/(±.010)
 EXCEPT WHERE NOTED

*"Fluorinert" is a registered trademark of 3M Co.
 †RoHS Directive 2002/95/EC Jan 27 2003 including Annex.
 Specifications are subject to change without notice.
 Customers should verify actual device performance in their specific applications.
 REV 09/04

Trimmer Data Sheets

Additional Features

- Patent #5043695 assembly for seal integrity
- Plastic housing for RF applications

3313 – Ordering Information and Packaging Specifications

Packaging Specifications

J Style

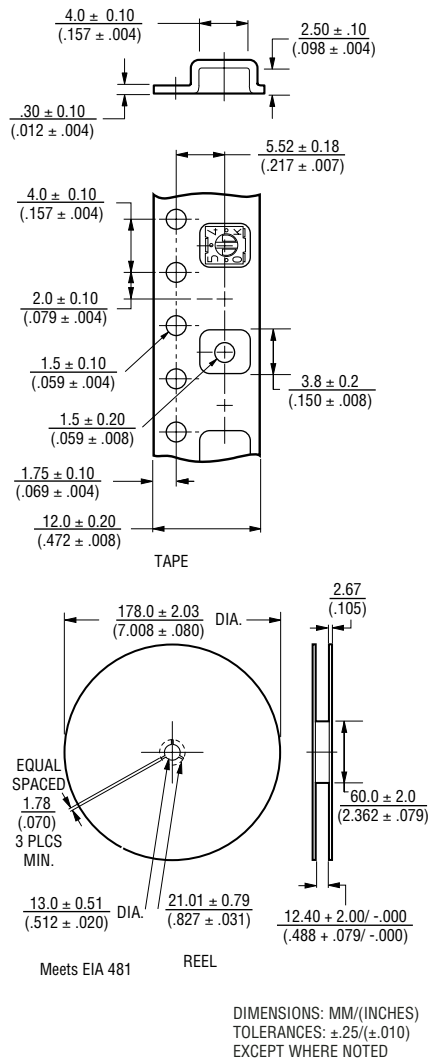

S Style

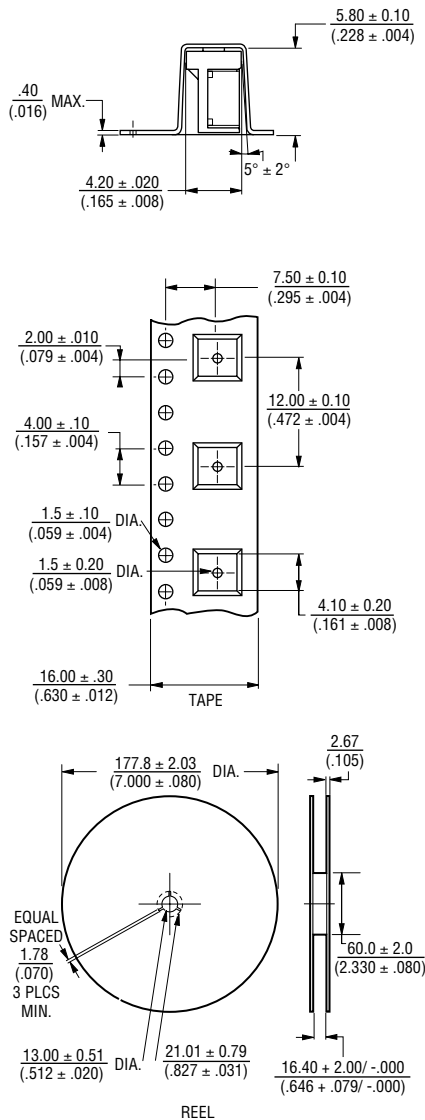

Standard Resistance Table

Resistance (Ohms)	Part Marking Code	Resistance Code
10	A1	100
20	21	200
50	51	500
100	A2	101
200	22	201
500	52	501
1,000	A3	102
2,000	23	202
5,000	53	502
10,000	A4	103
20,000	24	203
50,000	54	503
100,000	A5	104
200,000	25	204
500,000	55	504
1,000,000	A6	105
2,000,000	26	205

Popular distribution resistance values listed in **boldface**.
Special resistances available.

How To Order

Model 3313 J - 1 - 502 E

Style _____

Standard or Modified _____

Product Indicator _____
-1 = Standard Product

Resistance Code _____

Embossed Tape _____
1000 pcs. / 7" Reel (Standard)

Specifications are subject to change without notice.
Customers should verify actual device performance in their specific applications.

AVAILABLE THROUGH DISTRIBUTION

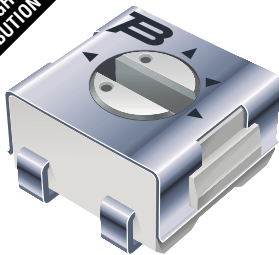

BOURNS®

3314 4 mm Square Trimming Potentiometer

Features

- Surface Mount / Single Turn / Cermet Industrial / Sealed
- Compatible with surface mount manufacturing processes
- Compatible with popular vacuum pick-and-place equipment
- J-hook, gull-wing and pinned configurations
- Side adjust available
- RoHS compliant* – See page 155 for processing information on lead free surface mount trimmers

Electrical Characteristics

Standard Resistance Range10 ohms to 2 megohms (see standard resistance table)
 Resistance Tolerance±20 % std. (tighter tolerance available)
 End Resistance1 % or 2 ohms max. (whichever is greater)
 Contact Resistance Variation3 % or 3 ohms
 ResolutionInfinite
 Insulation Resistance500 vdc. 100 megohms min.
 Dielectric Strength
 Sea Level500 vac (1 minute)
 Adjustment Angle210 ° nom.

Environmental Characteristics

Power Rating (300 volts max.)
 70 °C0.25 watt
 125 °C0 watt
 Temperature Range-55 °C to +125 °C
 Temperature Coefficient±100 ppm/°C
 Humidity90-98 % RH, 10 cycles, 240 hours
 TRS ±2 %; IR 10 megohms
 Vibration20 G TRS ±1 %; VRS ±1 %
 Shock100 G TRS ±1 %; VRS ±1 %
 Load Life(@ 70 °C Rated Power 1000 Hours)
 TRS ±3 %
 Rotational Life100 cycles
 TRS ±3 %
 Thermal Shock5 cycles
 TRS ±2 %; VRS ±1 %

Physical Characteristics

Mechanical Angle240 ° nom.
 Torque180 g-cm typical
 Stop Strength300 g-cm typical
 Pushover Strength (Z Style)2 kilograms (4.4 lbs.) minimum
 WeightApproximately 0.01 oz.
 MarkingManufacturer's code, resistance code and date code
 Wiper50 % (Actual TR) ±10 %
 FlammabilityU.L. 94V-0
 Standard Packaging
 J, G and R500 pcs./7 " reel
 S and Z200 pcs./7 " reel
 H100 pcs./tube
 Adjustment ToolH-90

Specifications are subject to change without notice.
 *RoHS Directive 2002/95/EC Jan 27 2003 including Annex.
 Customers should verify actual device performance in their specific applications. REV 09/04

Product Dimensions

3314J-1

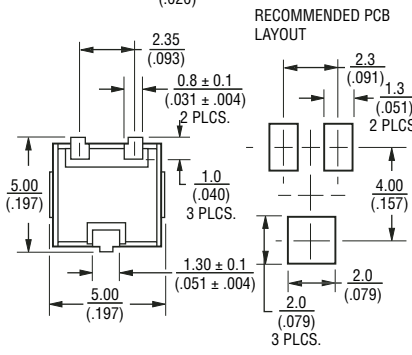
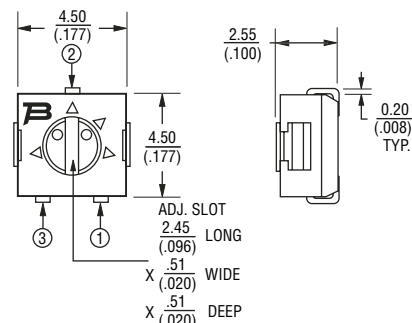

3314G-1

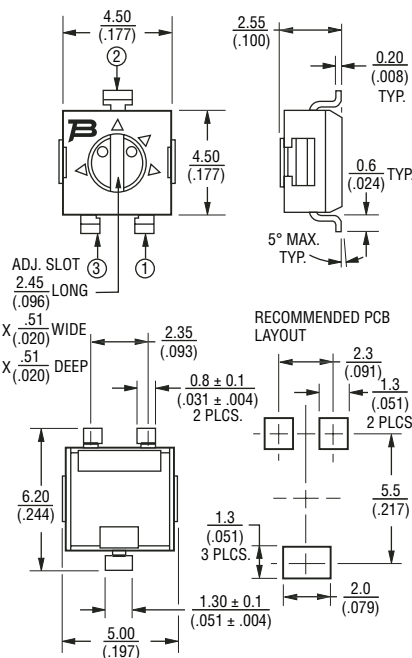

3314J-1, G-1, R-1, H-1 (Bourns Marking, Straight Slot)

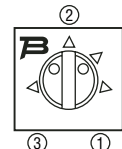

3314J-2, G-2, R-2, H-2 (Bourns Marking, Cross Slot)

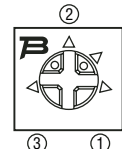

3314J-3, G-3, R-3, H-3 (Reverse Marking, Straight Slot)

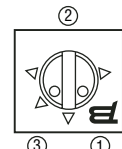

DIMENSIONS: MM/(INCHES)
 TOLERANCES: ±.25/(±.010) EXCEPT WHERE NOTED

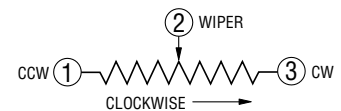

Additional Features

- Meets EIA/EIAJ/IPC/VECI SMD standard trimmer designs
- Model 3314 has been approved for use by DESC on drawings 88039 (3314J) and 90027 (3314G)

3314 – How to Order

Standard Resistance Table

Resistance (Ohms)	Resistance Code
10	100
20	200
50	500
100	101
200	201
500	501
1,000	102
2,000	202
5,000	502
10,000	103
20,000	203
50,000	503
100,000	104
200,000	204
250,000	254
500,000	504
1,000,000	105
2,000,000	205

Popular distribution resistance values listed in **boldface**.
Special resistances available.

How To Order

3314 J - 1 - 502 E

Model _____
 Style _____
 Standard or Modified Product Indicator (Styles J, G, R, H & S) _____
 -1 = Single Slot
 -2 = Cross Slot
 -3 = Single Slot w/Reverse Marking
 Product Indicator (Style Z only)
 -GA4 = Single Slot
 -1 = Cross Slot
 -3 = Single Slot w/Reverse Marking
 Resistance Code _____
 Embossed Tape Designator* _____
 E = Styles J, G and R: 500 pcs./7" reel
 Styles S and Z: 200 pcs./7" reel
 G = Styles J and G: 3000 pcs./13" reel
 Style R: 2500 pcs./13" reel
 Styles S and Z: 1000 pcs./13" reel
 *Style H is available in tube packaging only.

Specifications are subject to change without notice.
Customers should verify actual device performance in their specific applications.

3314 – Product Dimensions and Packaging Specifications

Product Dimensions

3314R-1

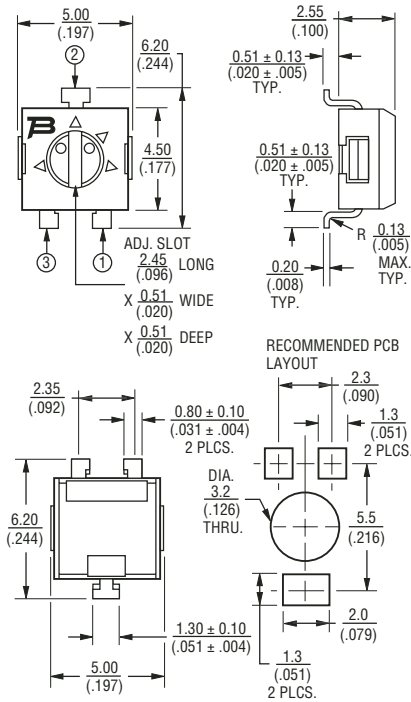

3314H-1

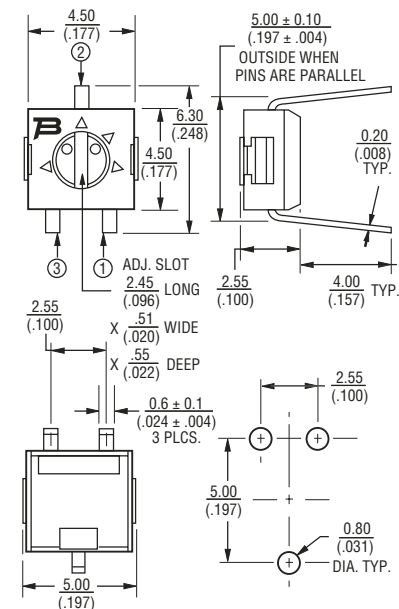

(J, G Styles)

TAPE

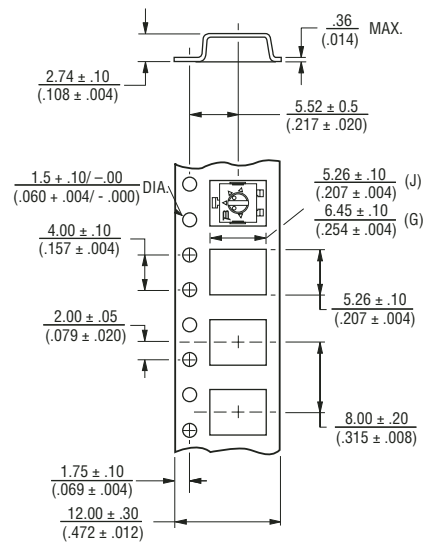

REEL

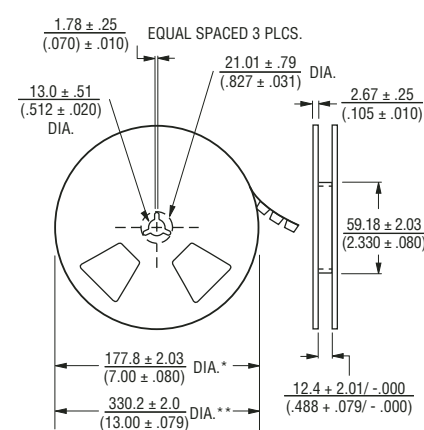

* Embossed Tape Designator "E"
** Embossed Tape Designator "G"
(See How To Order chart for further information.)

Meets EIA specification 481.

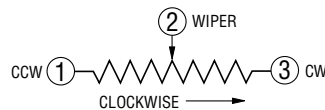

(R Style)

TAPE

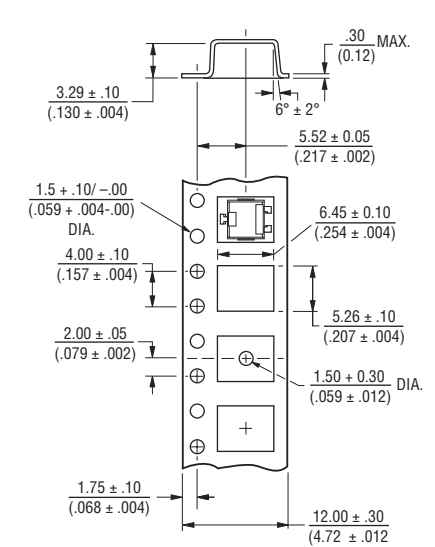

REEL

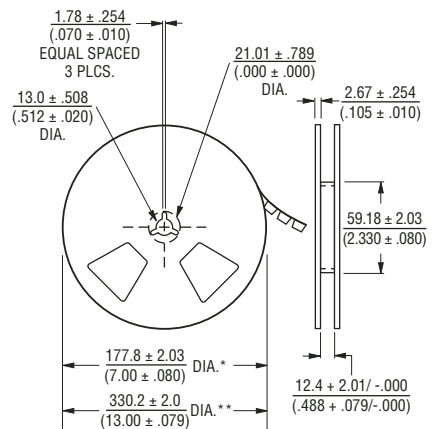

* Embossed Tape Designator "E"
** Embossed Tape Designator "G"
(See How To Order chart for further information.)

Meets EIA specification 481.

DIMENSIONS: MM/(INCHES)
TOLERANCES: ±.25/(±.010) EXCEPT WHERE NOTED

Specifications are subject to change without notice. Customers should verify actual device performance in their specific applications.

3314 – Product Dimensions and Packaging Specifications

Product Dimensions

3314S-1
(Bourns Marking, Straight Slot)

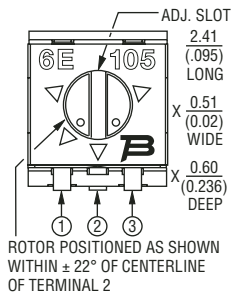

3314S-2
(Bourns Marking, Cross Slot)

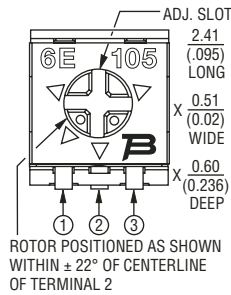

3314S-3
(Reverse Marking, Straight Slot)

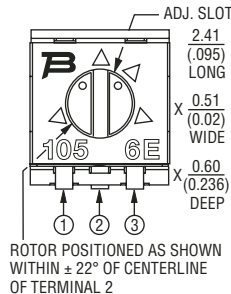

DIMENSIONS: MM/(INCHES)
TOLERANCES: ±.25/(±.010) EXCEPT WHERE NOTED

3314S
Common Dimensions

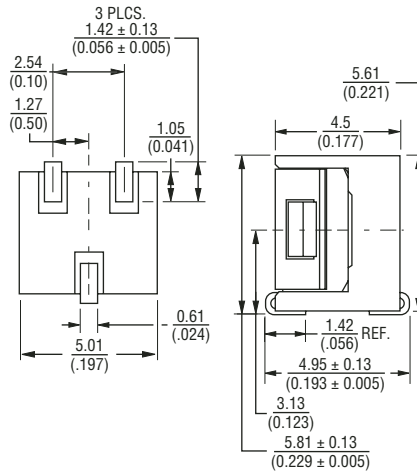

RECOMMENDED PCB LAYOUT

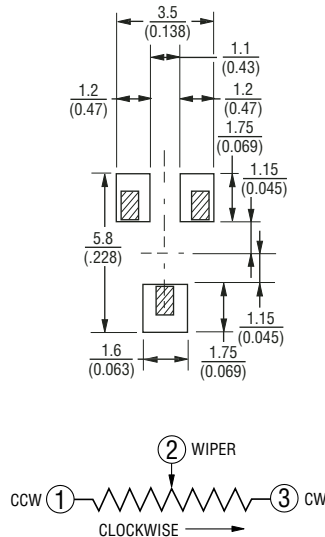

Specifications are subject to change without notice.
Customers should verify actual device performance in their specific applications.

DIMENSIONS: MM/(INCHES)
TOLERANCES: ±.30/(±.012) EXCEPT WHERE NOTED

Packaging Specifications

(S Style)

TAPE

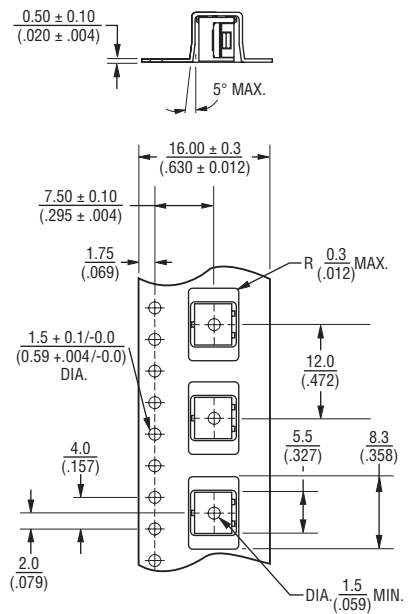

REEL

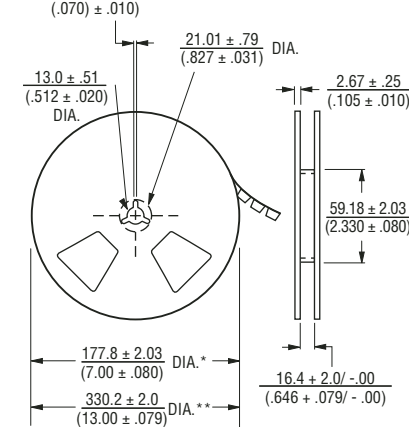

* Embossed Tape Designator "E"
** Embossed Tape Designator "G"
(See How To Order chart for further information.)

Meets EIA specification 481.

DIMENSIONS: MM/(INCHES)
TOLERANCES: ±.25/(±.010) EXCEPT WHERE NOTED

3314 – Product Dimensions and Packaging Specifications

Product Dimensions

3314Z-1-(RC) E (Cross Slot)

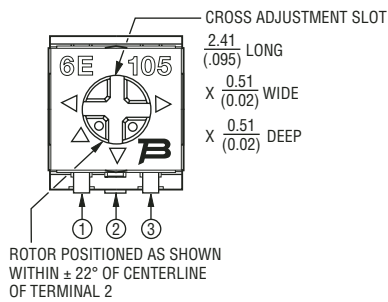

3314Z-GA4-(RC) E (Straight Slot)

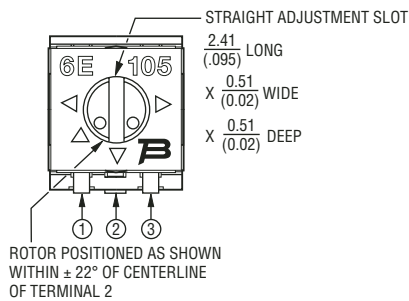

3314Z-3 (Reverse Marking, Straight Slot)

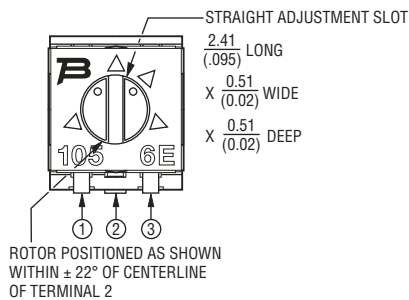

Specifications are subject to change without notice. Customers should verify actual device performance in their specific applications.

3314Z Common Dimensions

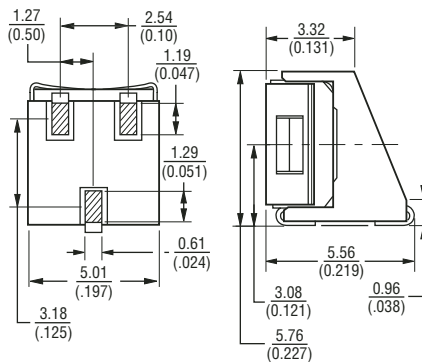

RECOMMENDED PCB LAYOUT

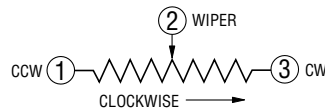
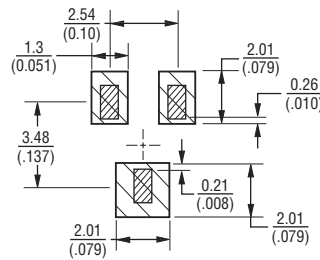

DIMENSIONS: MM/(INCHES)
 TOLERANCES: ±.25/(±.010) EXCEPT WHERE NOTED

Packaging Specifications

(Z Style)

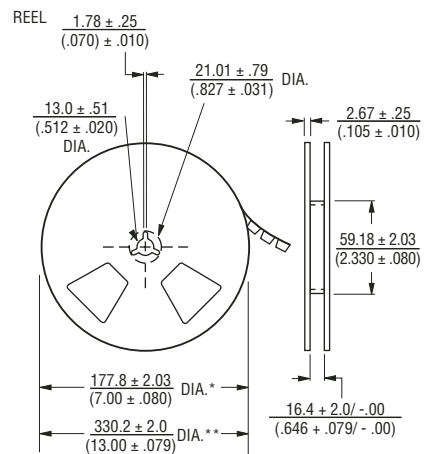
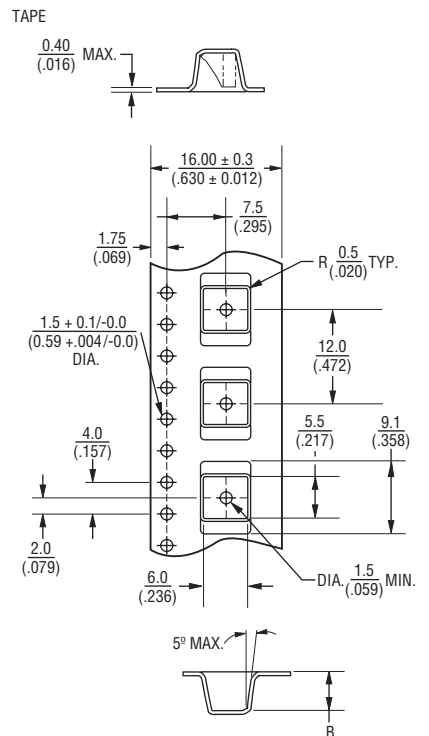

* Embossed Tape Designator "E"
 ** Embossed Tape Designator "G"
 (See How To Order chart for further information.)

Meets EIA specification 481.

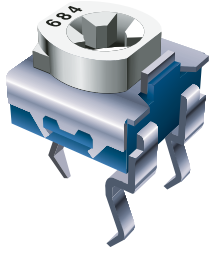

BOURNS®

3318 6 mm Square Trimming Potentiometer

Features

- Single-Turn / Carbon / Commercial Open Frame
- Cross slot rotor design suitable for automatic adjustment equipment
- Board retention features
- Enclosed cover
- PC board stand-offs
- Adjustable front / back, top / bottom
- RoHS compliant*

Electrical Characteristics

Standard Resistance Range100 Ω to 1 MΩ
 (see standard resistance table)
 Resistance Tolerance.....±20 %
 Contact Resistance Variation10 % max.
 Resolution.....Infinite
 Adjustment Angle210 °± 15 °

Environmental Characteristics

Power Rating0.1 watt
 Temperature Range.....-10 °C to +70 °C
 Temperature Coefficient.....±1,000 PPM/°C
 Load Life.....240 hours @ 50 °C
 (+20/-5 % ΔTR)

Physical Characteristics

Torque (Operating)20~250 gf-cm
 Stop Strength
 Knob Side800 gf-cm
 Reverse Side350 gf-cm
 TerminalsSolderable pins
 MarkingResistance code
 Standard Packaging500 pcs. per bag

Product Dimensions

Model 3318S

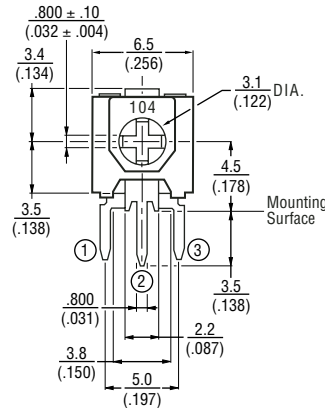

Model 3318P

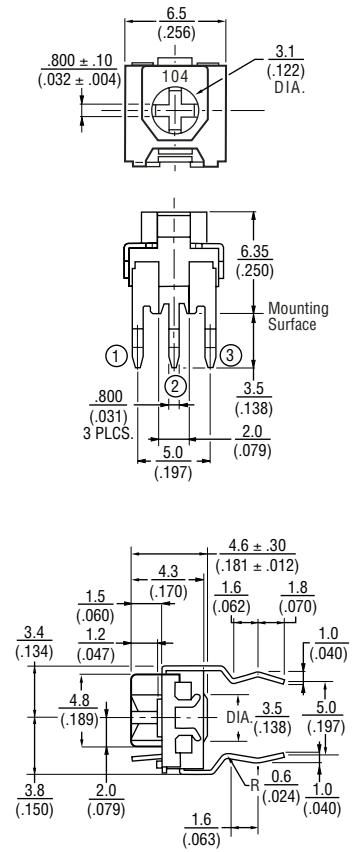

Recommended PCB Layout

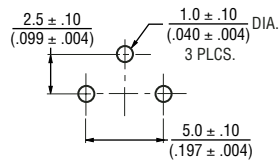

Recommended PCB Layout

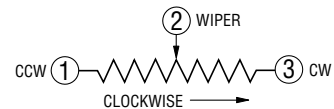
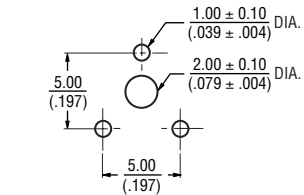

DIMENSIONS: MM/(INCHES)
 TOLERANCES: ±.25(±.010) EXCEPT WHERE NOTED

Specifications are subject to change without notice.
 *RoHS Directive 2002/95/EC Jan 27 2003 Including Annex.
 Customers should verify actual device performance in their specific applications.
 REV 09/04

3318 – Product Dimensions and Ordering Information

Product Dimensions

Model 3318B

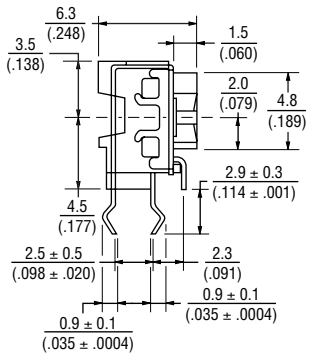
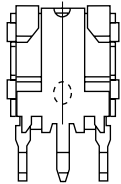
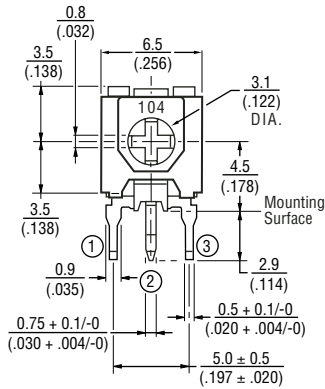

Recommended PCB Layout

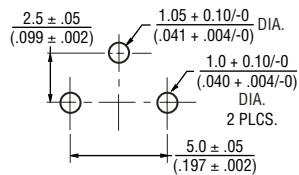

DIMENSIONS: MM/(INCHES)
TOLERANCES: ±.25/(±.010) EXCEPT WHERE NOTED

Standard Resistance Table

Resistance (Ohms)	Resistance Code
100	101
200	201
220	221
300	301
500	501
1,000	102
2,000	202
2,200	222
3,000	302
3,300	332
4,700	472
5,000	502
10,000	103
20,000	203
22,000	223
30,000	303
47,000	473
50,000	503
100,000	104
200,000	204
220,000	224
470,000	474
500,000	504
1,000,000	105

How To Order

Model 3318 P - 1 - 103 A
 Style _____
 Standard or Modified _____
 Product Indicator _____
 -1 = Standard Product
 Resistance Code _____
 Ammo Pak Designator _____
 (G, S & B only)

Specifications are subject to change without notice.
Customers should verify actual device performance in their specific applications.

3318 – Packaging Specifications

Ammo Pack Model 3318S

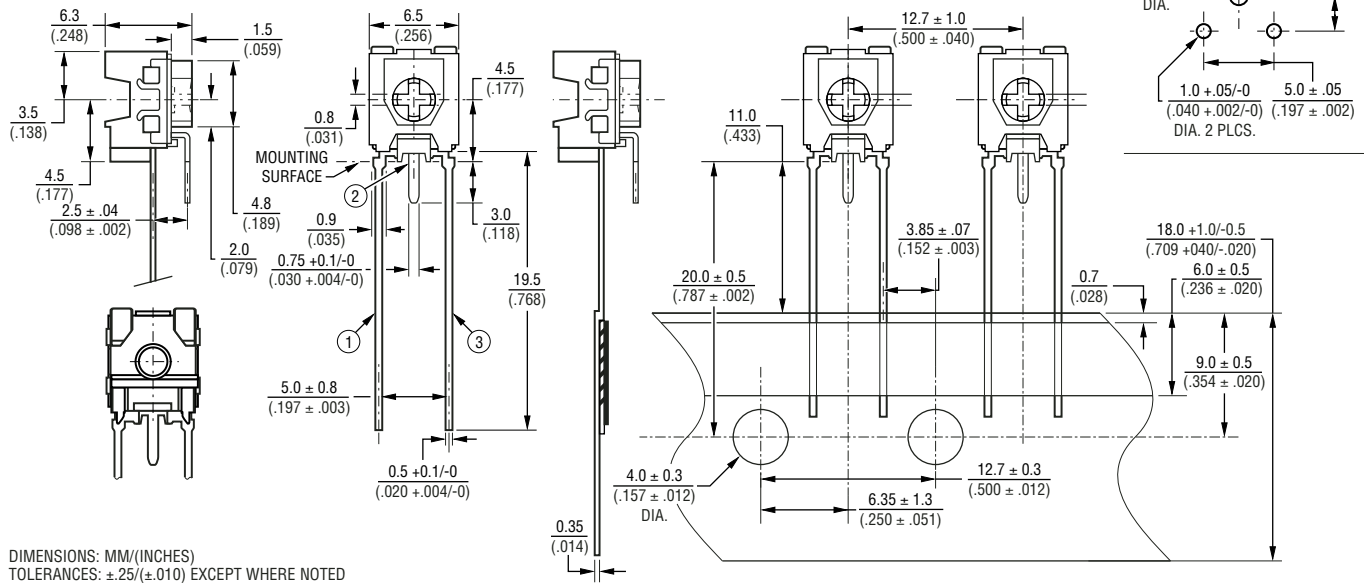

DIMENSIONS: MM/(INCHES)
TOLERANCES: $\pm 0.25/(\pm 0.010)$ EXCEPT WHERE NOTED

Ammo Pack Model 3318G

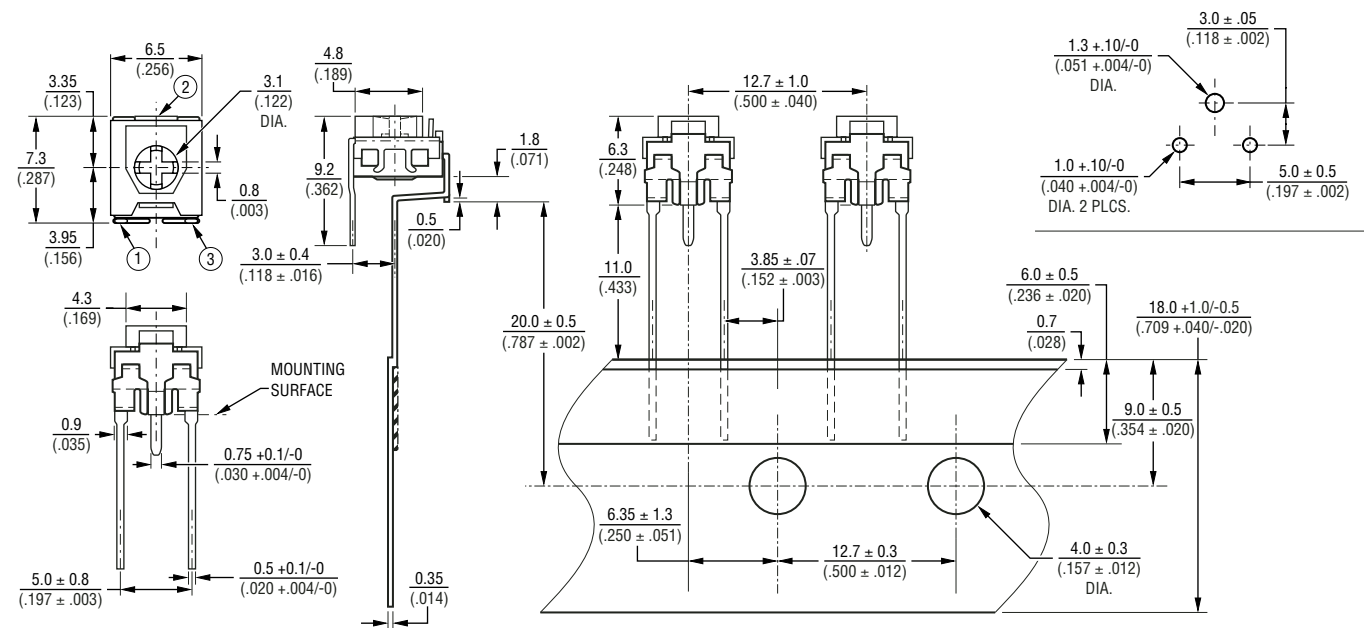

Specifications are subject to change without notice.
Customers should verify actual device performance in their specific applications.

3318 – Packaging Specifications

Ammo Pack Model 3318B

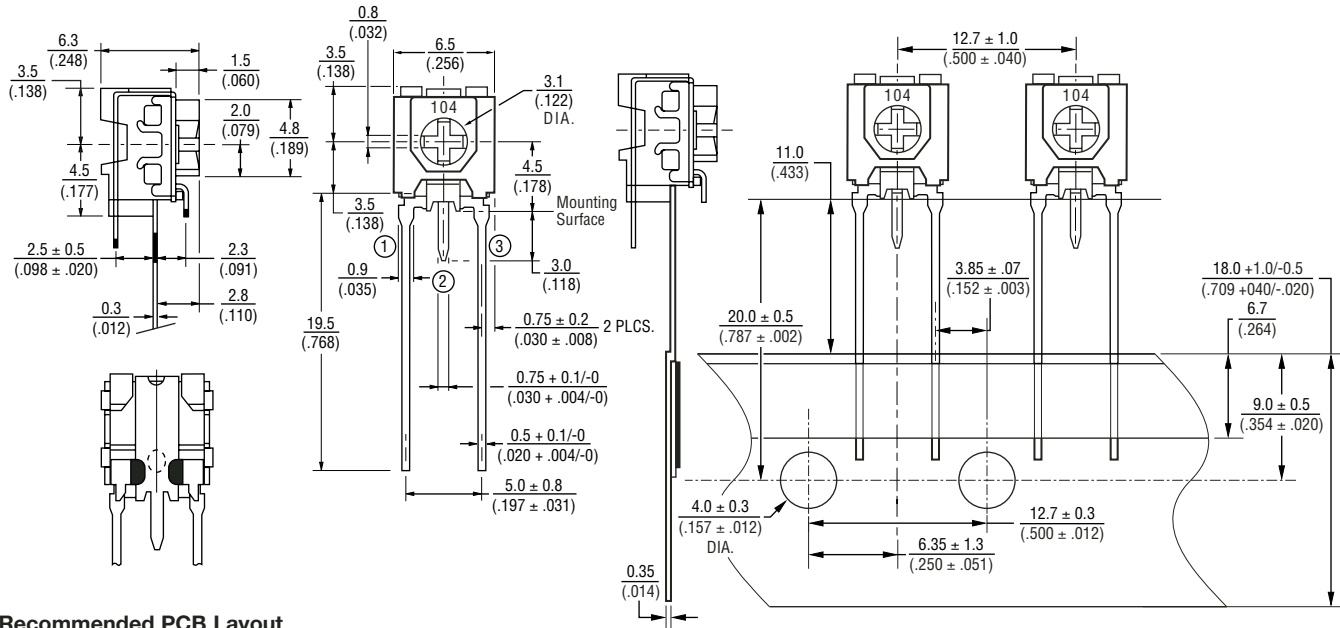

Recommended PCB Layout

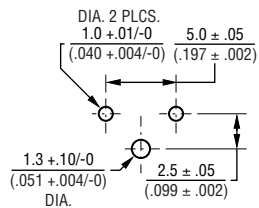

DIMENSIONS: MM/(INCHES)
TOLERANCES: ±.25/(±.010) EXCEPT WHERE NOTED

Specifications are subject to change without notice.
Customers should verify actual device performance in their specific applications.

AVAILABLE THROUGH DISTRIBUTION

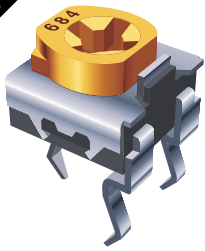

BOURNS®

3318 6 mm Square Trimming Potentiometer

Features

- Single-Turn / Carbon / Commercial Open Frame
- Cross slot rotor design suitable for automatic adjustment equipment
- Board retention feature
- Enclosed cover
- PC board stand-offs
- Adjustable front/back, top/bottom
- RoHS compliant*

Electrical Characteristics

Standard Resistance Range100 to 1 megohm
(see standard resistance table)
Resistance Tolerance±30 %
Contact Resistance Variation10 % max.
Resolution.....Infinite
Adjustment Angle210 ° ±20 °

Environmental Characteristics

Power Rating
100-500K ohms50 V
>500K ohms.....25 V
50 °C0.1 watt
Temperature Range.....-25 °C to +100 °C
Temperature Coefficient±1000 ppm/°C
Load Life.....1,000 hours 0.1 watt @ 70 °C
(20 % ΔTR)

Physical Characteristics

Torque (Operating).....20-250 g-cm
Stop Strength
Knob Side750 g-cm
Reverse Side350 g-cm
TerminalsSolderable pins
MarkingResistance code, date code
Standard Packaging200 pcs. per bag
Adjustment ToolH-90
Aqueous cleaning not recommended

Standard Resistance Table

Resistance		Resistance	
Ohms	Code	Ohms	Code
100	101	20,000	203
200	201	50,000	503
500	501	100,000	104
1,000	102	200,000	204
2,000	202	500,000	504
5,000	502	1,000,000	105
10,000	103		

Popular distribution resistance values listed in **boldface**. Others are typically not stocked by distributors and are not recommended for new designs.

How To Order

Model 3318 K - 1 - 103 A
Style _____
Standard Product _____
Resistance Code _____
Ammo Pak Designator _____

Product Dimensions

3318K

FRONT VIEW

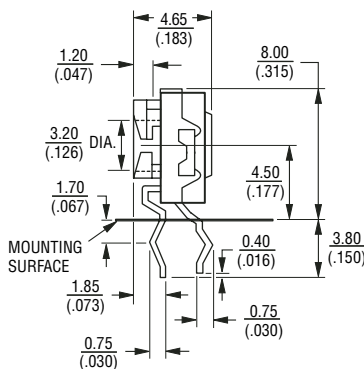
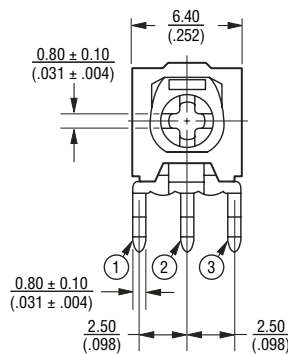

REAR VIEW

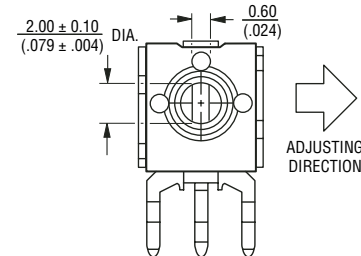

SUGGESTED PWB LAYOUT

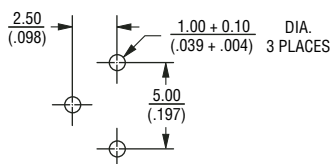

DIMENSIONS: MM/(INCHES)
TOLERANCES: ±.25(±.010) EXCEPT WHERE NOTED

3318F

FRONT VIEW

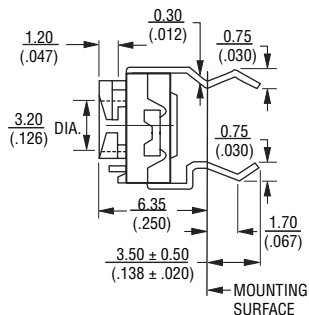
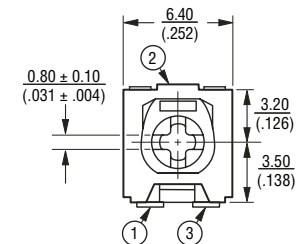

REAR VIEW

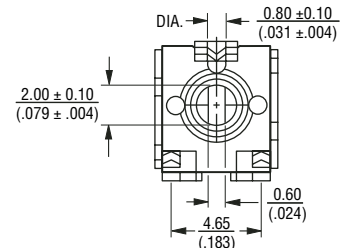

SUGGESTED PWB LAYOUT

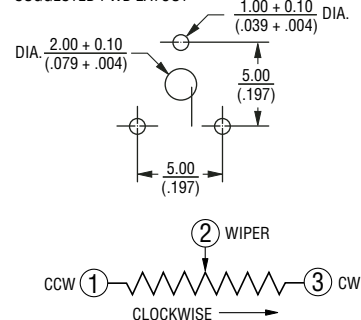

Specifications are subject to change without notice.
*RoHS Directive 2002/95/EC Jan 27 2003 including Annex.
Customers should verify actual device performance in their specific applications.
REV 09/04

Trimmer Data Sheets

3318 – Packaging Specifications

Ammo Pack Model 3318K

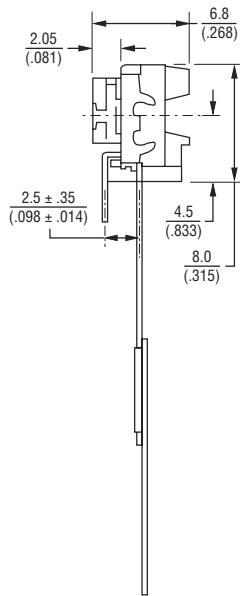

Recommended PCB Layout

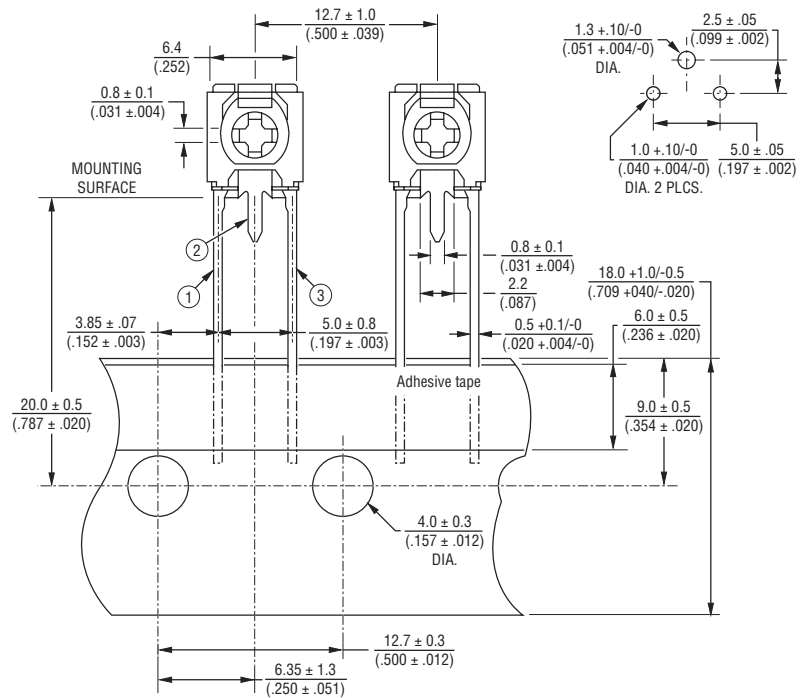

DIMENSIONS: MM/(INCHES)
TOLERANCES: ±.25/(±.010) EXCEPT WHERE NOTED

Ammo Pack Model 3318F

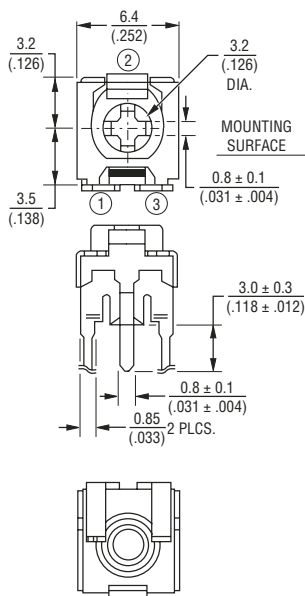

Recommended PCB Layout

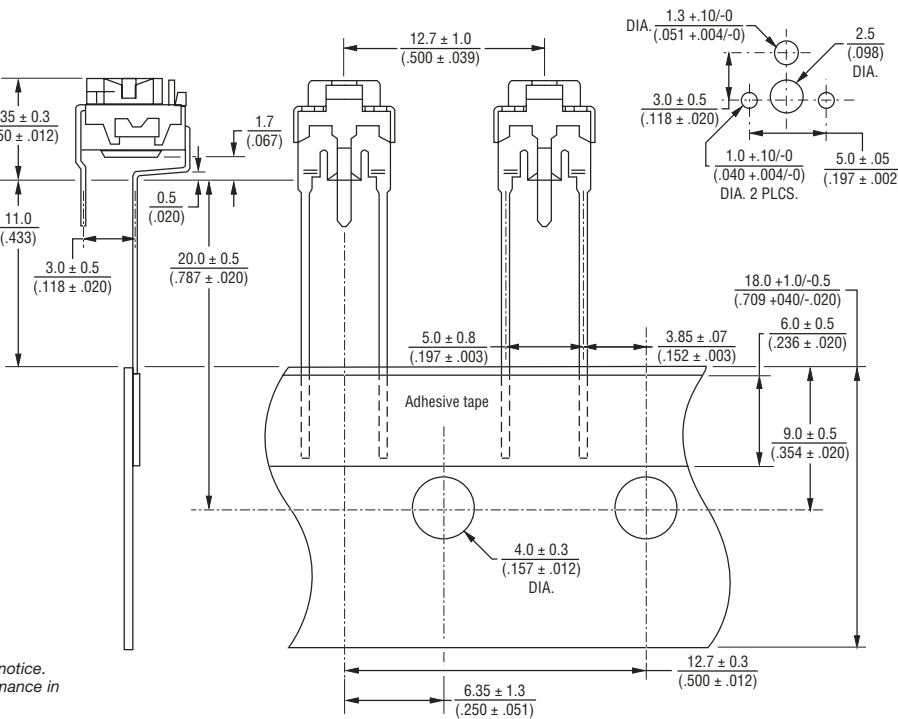

Specifications are subject to change without notice.
Customers should verify actual device performance in their specific applications.

AVAILABLE THROUGH DISTRIBUTION



BOURNS®

3319 9 mm Round Trimming Potentiometer

Features

- 9 mm Round / Single-Turn / Carbon Commercial / Open Frame
- Both sides adjust
- Cross slot and hexagon adjustment designs
- Horizontal and vertical mounting styles
- Dust resistant/splash resistant covers
- PC board stand-offs and retention feature
- RoHS compliant*

Electrical Characteristics

Standard Resistance Range100 to 1 megohm
(see standard resistance table)
Resistance Tolerance±25 % std.
End Resistance2 % max. (≤2K = 30 ohms)
Contact Resistance Variation3 % max.
ResolutionInfinite
Adjustment Angle235 ° nom.

Environmental Characteristics

Power Rating (200 volts max.)
70 °C0.2 watt
Temperature Range-25 °C to +100 °C
Temperature Coefficient ±1000 ppm/°C
Load Life1,000 hours 0.2 watt @ 70 °C
(<100K = +3/-7 % ΔTR)
(≤100K = +3/-10 % ΔTR)

Physical Characteristics

Torque (Operating)5 oz-in. max.
Stop Strength11.0 oz-in. min.
TerminalsSolderable pins
MarkingManufacturer's trademark, resistance code
Standard Packaging200 pcs. per bag
Adjustment ToolH-90

Aqueous cleaning not recommended

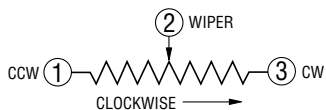

Product Dimensions

3319P Common Dimensions

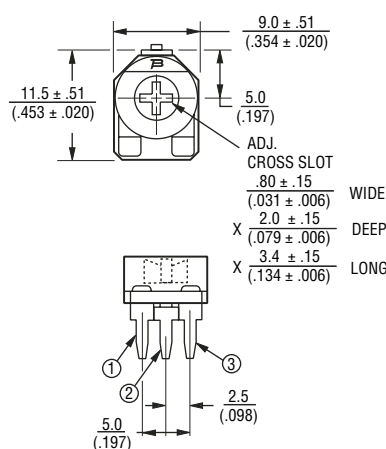

3319P-1 Top Adjust

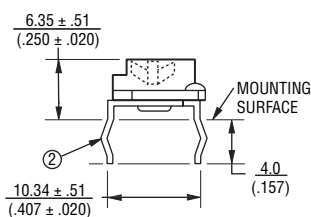

3319P-2 Both Sides Adjust/Cross Slot

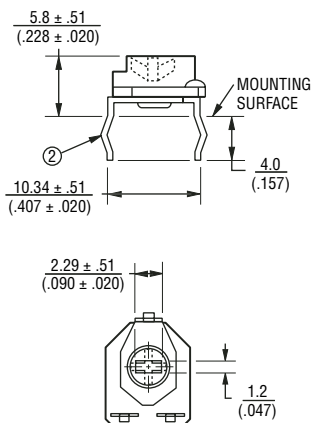

3319P-3 Both Sides Adjust/Hex

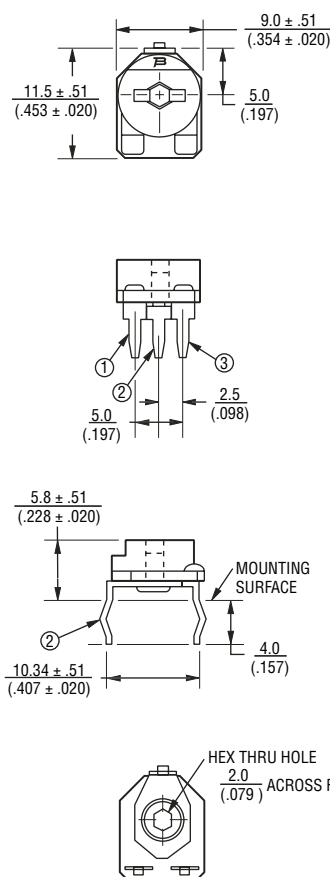

SUGGESTED PWB LAYOUT - 3319P

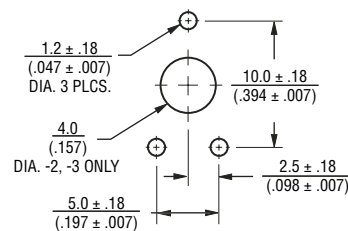

DIMENSIONS: MM/(INCHES)
TOLERANCES: ±.25/(±.010) EXCEPT WHERE NOTED

Specifications are subject to change without notice.
*RoHS Directive 2002/95/EC Jan 27 2003 Including Annex.
Customers should verify actual device performance in their specific applications.
REV 09/04

3319 – Product Dimensions and Ordering Information

Side Adjust 3319W-1

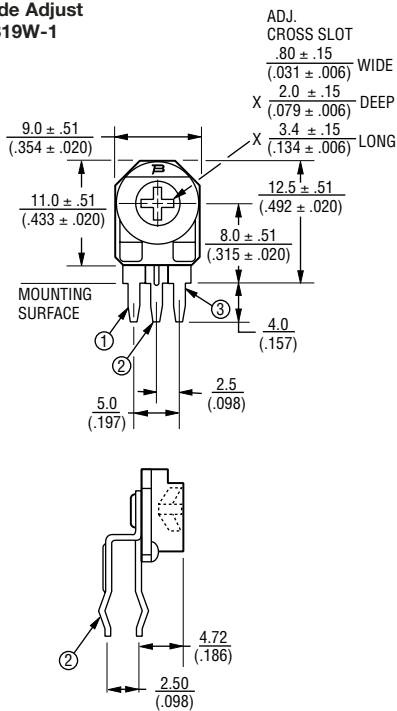

3319W-2 Both Sides Adjust /Cross Slot

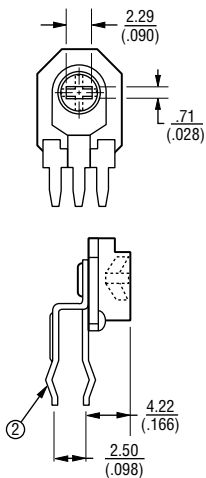

DIMENSIONS: MM/(INCHES)
 TOLERANCES: ±.25/(±.010) EXCEPT WHERE NOTED

3319W-3 Both Sides Adjust/Hex

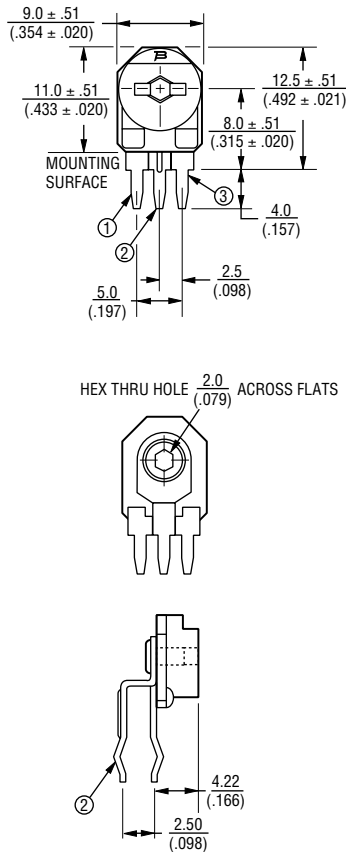

SUGGESTED PWB LAYOUT - 3319W

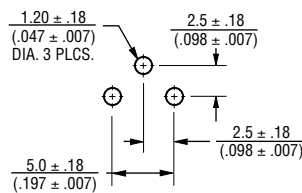

Standard Resistance Table

Resistance (Ohms)	Resistance Code
100	101
200	201
500	501
1,000	102
2,000	202
5,000	502
10,000	103
20,000	203
50,000	503
100,000	104
200,000	204
500,000	504
1,000,000	105

Popular distribution resistance values listed in **boldface**.

How To Order

Model **3319 W - 2 - 103**

Pin Style _____

Rotor Style _____
 -2 = Cross Slot/Single Slot Rear Adjust
 -3 = 2 mm Hex Thru Hole

Resistance Code _____

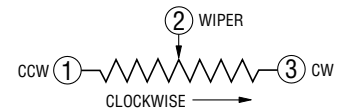

Specifications are subject to change without notice.
 Customers should verify actual device performance in
 their specific applications.

AVAILABLE THROUGH DISTRIBUTION

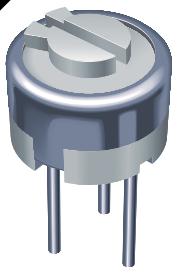

3329 1/4" Round Trimming Potentiometer

Features

- 1/4" Round / Single-Turn / Cermet Industrial / Sealed
- 5 standard terminal styles
- Tape and reel packaging available
- Listed on the QPL for style RJ50 per MIL-PRF-22097 and RJ50 per High-Rel MIL-PRF-39035
- RoHS compliant[†] version available

BOURNS®

Electrical Characteristics

Standard Resistance Range10 to 1 megohm
(see standard resistance table)
Resistance Tolerance±10 % std.
(closer tolerance available)
Absolute Minimum Resistance1 % or 2 ohms
(whichever is greater)
Contact Resistance Variation3.0 % or 3 ohms max.
(whichever is greater)
Adjustability
Voltage±0.05 %
Resistance±0.15 %
ResolutionInfinite
Insulation Resistance500 vdc.
1,000 megohms min.
Dielectric Strength
Sea Level600 vac
80,000 Feet250 vac
Adjustment Angle240 ° nom.

Environmental Characteristics

Power Rating @ 85 °C (300 volts max.)0.5 watt
Power Rating @ 150 °C0 watt
Temperature Range-55 °C to +150 °C
Temperature Coefficient±100 ppm/°C
Seal Test85 °C Fluorinert^{*}
HumidityMIL-STD-202 Method 106
96 hours
(3 % ΔTR, 10 Megohms IR)
Vibration30 G (1 % ΔTR; 1 % ΔVR)
except "P" pin style
Shock100 G (1 % ΔTR; 1 % ΔVR)
Load Life1,000 hours 0.5 watt @ 85 °C
(3 % ΔTR; 3 % CRV)
Rotational Life200 cycles
(4 % ΔTR; 4 % CRV)

Physical Characteristics

Mechanical Angle260 ° nom.
Torque5.0 oz-in. max.
Stop Strength5.0 oz-in. min.
TerminalsSolderable pins
Weight0.02 oz.
MarkingManufacturer's trademark,
resistance code, date code,
manufacturer's model number
and style
Wiper50 % (Actual TR) ±10 %
Standard Packaging50 pcs. per tube
Adjustment ToolH-90

Product Dimensions

3329H

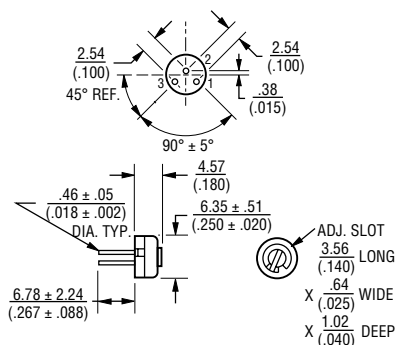

3329P

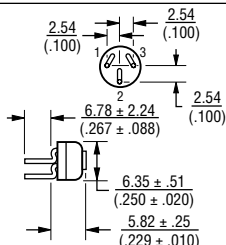

3329S

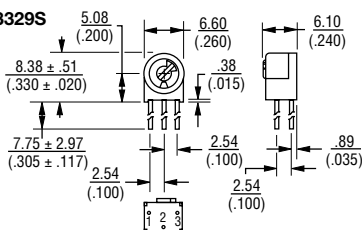

3329W

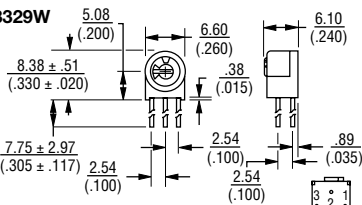

3329X

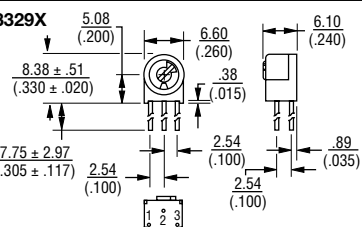

3329P-DK9-RC

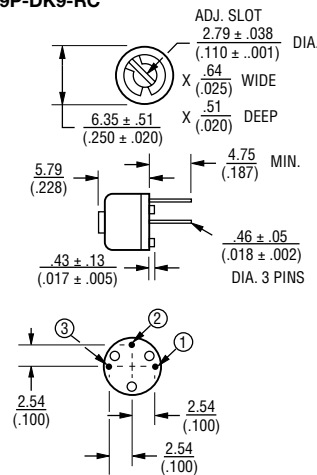

DIMENSIONS: MM/(INCHES)
TOLERANCES: ±.25/(±.010) EXCEPT WHERE NOTED

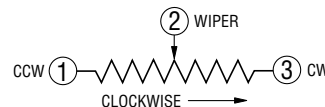

^{*}"Fluorinert" is a registered trademark of 3M Co.
[†]RoHS Directive 2002/95/EC Jan 27 2003 including Annex.
Specifications are subject to change without notice.
Customers should verify actual device performance in their specific applications.
REV 09/04

3329 – Packaging Specifications and Ordering Information

Packaging Specifications

SIDE ADJUST 3329M-1

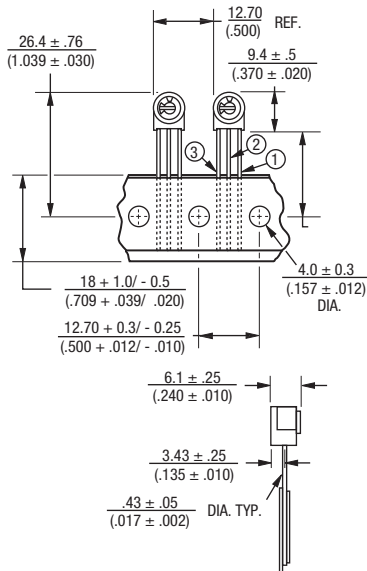

ALL PINS IN-LINE ON $\frac{2.54}{(.100)}$ CENTER
 DIMENSIONS: $\frac{\text{MM}}{\text{(INCHES)}}$
 1000/REEL/BOX

Meets EIA Specification 468.

TOP ADJUST 3329U-1

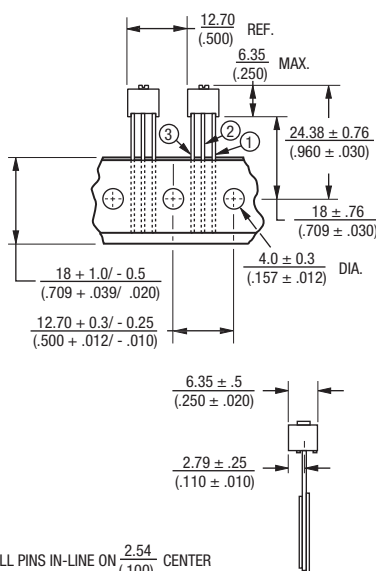

ALL PINS IN-LINE ON $\frac{2.54}{(.100)}$ CENTER
 DIMENSIONS: $\frac{\text{MM}}{\text{(INCHES)}}$
 1000/REEL/BOX

Meets EIA Specification 468.

Standard Resistance Table

Resistance (Ohms)	Resistance Code
10	100
20	200
50	500
100	101
200	201
500	501
1,000	102
2,000	202
5,000	502
10,000	103
20,000	203
25,000	253
50,000	503
100,000	104
200,000	204
250,000	254
500,000	504
1,000,000	105

Popular distribution resistance values listed in **boldface**.
 Special resistances available.

How To Order

3329 M - 1 - 103 LF

Model _____
 Style _____
 Standard or Modified Product Indicator _____
 -1 = Standard Product
 -DK9 = Plastic Spacer
 Resistance Code _____
 Packaging Designator _____
 Blank = Tube (Standard)
 R = Tape and Reel (M and U Pin Styles Only)
 A = Ammo Pack (M and U Pin Styles Only)
 Terminations _____
 LF = 100 % Tin-plated (RoHS compliant)
 Blank = 90 % Tin / 10 % Lead-plated (Standard)

Consult factory for other available options.

Specifications are subject to change without notice.
 Customers should verify actual device performance in their specific applications.

AVAILABLE THROUGH DISTRIBUTION

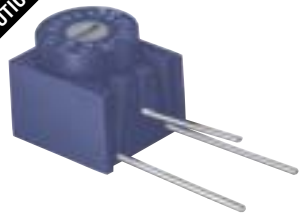

BOURNS®

3339 5/16" Round Trimming Potentiometer

Features

- Four-Turn / Cermet / Industrial / Sealed
- Unique planetary drive offers precise wiper setting of a multiturn in a single-turn package size
- Top and side adjust styles
- RoHS compliant* version available

Electrical Characteristics

Standard Resistance Range10 to 1 megohm (see standard resistance table)
 Resistance Tolerance±10 % std. (tighter tolerance available)
 Absolute Minimum Resistance1 % or 2 ohms max. (whichever is greater)
 Contact Resistance Variation3 % or 3 ohms max. (whichever is greater)
 Adjustability
 Voltage±0.05 %
 Resistance±0.1 %
 ResolutionInfinite
 Insulation Resistance500 vdc. 1,000 megohms min.
 Dielectric Strength
 Sea Level600 vac
 80,000 Feet250 vac
 Effective Travel4 turns nom.

Environmental Characteristics

Power Rating (300 volts max.)
 85 °C0.5 watt
 150 °C0 watt
 Temperature Range-55 °C to +150 °C
 Temperature Coefficient ±100 ppm/°C
 Seal Test85 °C Fluorinert*
 HumidityMIL-STD-202 Method 103 96 hours (3 % ΔTR, 10 Megohms IR)
 Vibration30 G (1 % ΔTR; 1 % ΔVR)
 Shock100 G (1 % ΔTR; 1 % ΔVR)
 Load Life1,000 hours 0.5 watt @ 85 °C (3 % ΔTR; 3 % or 3 ohms, whichever is greater, CRV)
 Rotational Life200 cycles (3 % ΔTR; 3 % or 3 ohms, whichever is greater, CRV)

Physical Characteristics

Torque3 oz-in. max.
 Mechanical StopsWiper idles
 TerminalsSolderable pins
 Weight0.02 oz.
 MarkingManufacturer's trademark, resistance code, wiring diagram, date code, manufacturer's model number and style
 Wiper50 % (Actual TR) ±10 %
 FlammabilityU.L. 94V-0
 Standard Packaging50 pcs. per tube
 Adjustment ToolH-90

Product Dimensions

3339H

Common Dimensions (Top Adjust)

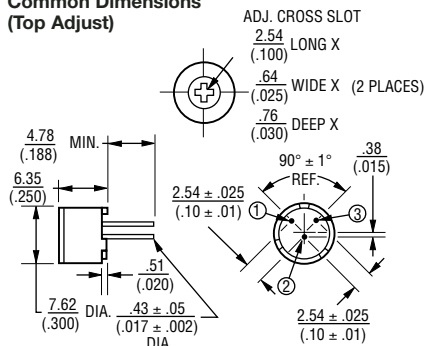

3339P

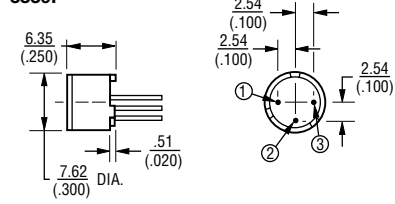

3339S

Common Dimensions (Side Adjust)

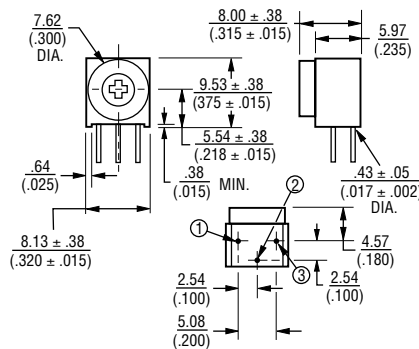

3339W

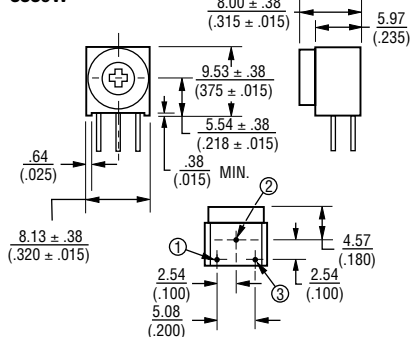

Standard Resistance Table

Resistance (Ohms)	Resistance Code
10	100
20	200
50	500
100	101
200	201
500	501
1,000	102
2,000	202
5,000	502
10,000	103
20,000	203
25,000	253
50,000	503
100,000	104
200,000	204
250,000	254
500,000	504
1,000,000	105

Popular distribution resistance values listed in **boldface**. Special resistances available.

How To Order

3339 H - 1 - 103 LF

Model _____
 Style _____
 Standard or Modified _____
 Product Indicator _____
 -1 = Standard Product
 Resistance Code _____
 Terminations _____
 LF = 100 % Tin-plated (RoHS compliant)
 Blank = 90 % Tin / 10 % Lead-plated (Standard)
 Consult factory for other available options.

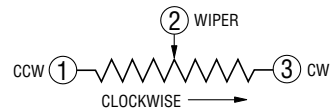

DIMENSIONS: MM/(INCHES)
 TOLERANCES: ±.25/(±.010) EXCEPT WHERE NOTED

*"Fluorinert" is a registered trademark of 3M Co.
 *RoHS Directive 2002/95/EC Jan 27 2003 including Annex. Specifications are subject to change without notice. Customers should verify actual device performance in their specific applications. REV 09/04

Trimmer Data Sheets

AVAILABLE THROUGH DISTRIBUTION

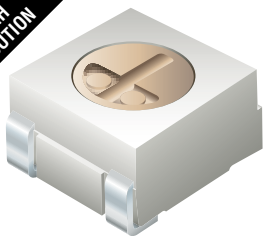

BOURNS®

3342 2 mm Trimming Potentiometer

Features

- 2 mm Square / Surface Mount / Single-Turn / Sealed
- Compatible with surface mount manufacturing processes
- Miniature design for flexibility
- Constructed with lead free materials
- Rotor stop for "in circuit" adjustment
- RoHS compliant* – See page 155 for processing information on lead free surface mount trimmers

Electrical Characteristics

Standard Resistance Range
100 ohms to 2 megohms
 (see standard resistance table)
 Resistance Tolerance.....±20 % std.
 End Resistance.....1 % or 3 ohms max.
 (whichever is greater)
 Contact Resistance Variation
5 % or 3 ohms max.
 (whichever is greater)
 Adjustability
 Voltage Divider.....±0.4 %
 Rheostat.....±0.4 %
 Resolution.....Essentially infinite
 Insulation Resistance @ 500 VDC
100 megohms min.
 Dielectric Strength
 Sea Level.....500 VAC
 70,000 Feet.....350 VAC
 Adjustment Angle.....220 ° nominal

Environmental Characteristics

Power Rating (50 volts max.)
 70 °C.....0.1 watt
 125 °C.....0 watt
 Operating Temperature Range
-55 °C to +125 °C
 Temperature Coefficient
 ≤ 100 Ohms.....±150 ppm/°C
 > 100 Ohms.....±100 ppm/°C
 Seal Test.....85 °C Fluorinert*
 Humidity.....MIL-STD-202 Method 106
 (no vibration) TRS ±3 %
 IR 10 megohms
 Vibration.....20 G
 TRS ±1 %; VRS ±1 %
 Shock.....100 G
 TRS ±1 %; VRS ±1 %
 Load Life @ 70 °C Rated Power
TRS ±3 %
 Rotational Life.....25 cycles
 TRS ±3 %
 Thermal Shock.....5 cycles
 TRS ±2 %; VRS ±1 %

Physical Characteristics

Mechanical Angle.....250 ° nom.
 Torque.....0.7 oz-in. max.
 Stop Strength.....0.7 oz-in. min.
 Flammability.....U.L. 94V-0
 Weight.....Approximately 0.01 oz.
 Marking.....Resistance code
 and date code
 Wiper.....50 % (Actual TR) ±10 %
 Standard Packaging.....1000 pcs./7 " reel
 Adjustment Tool.....H-92-1

Product Dimensions

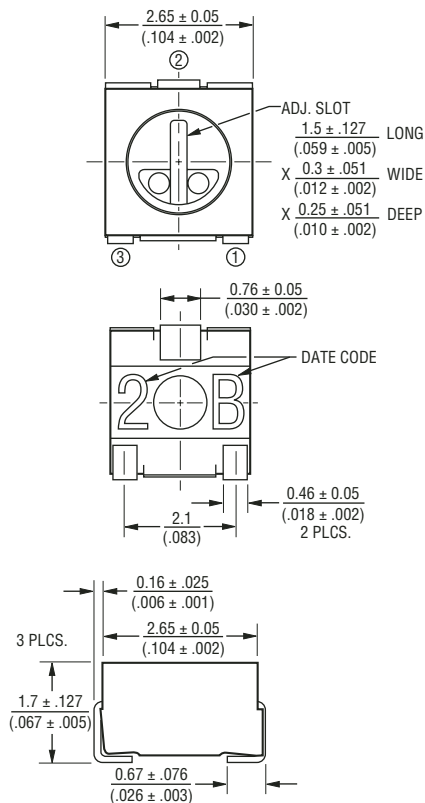

Recommended Land Pattern

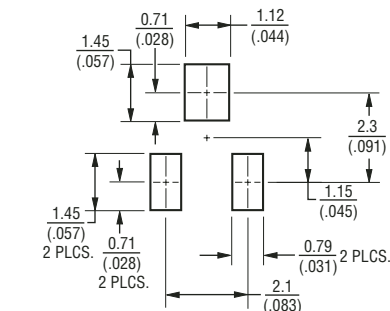

DIMENSIONS: MM/(INCHES)
 TOLERANCES: ±.25(±.010) EXCEPT WHERE NOTED

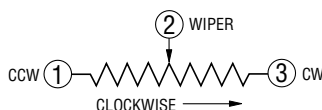

Standard Resistance Table

Resistance (Ohms)	Resistance Code
100	101
200	201
500	501
1,000	102
2,000	202
5,000	502
10,000	103
20,000	203
50,000	503
100,000	104
200,000	204
500,000	504
1,000,000	105
2,000,000	205

How To Order

Model 3342 J - 1 - 502 E
 Style _____
 Standard or Modified Product Indicator _____
 -1 = Standard Product
 Resistance Code _____
 Embossed Tape Designator _____

*"Fluorinert" is a registered trademark of 3M Co.
 *RoHS Directive 2002/95/EC Jan 27 2003 including Annex.
 Specifications are subject to change without notice.
 Customers should verify actual device performance in their specific applications. REV 10/04

Additional Features

- Automated placement compatible

3342 – Packaging Specifications

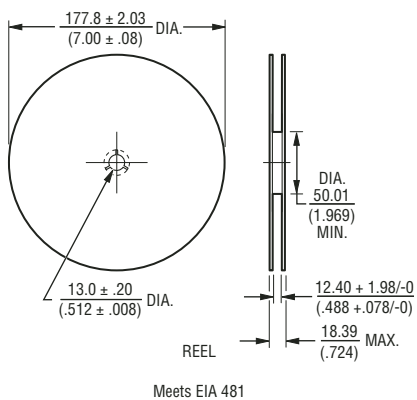
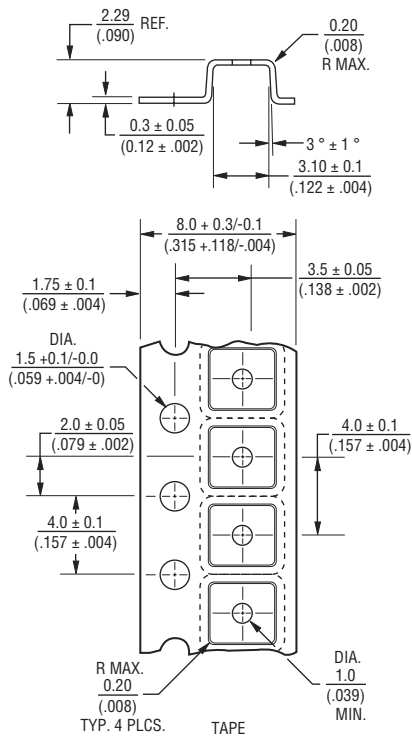

DIMENSIONS: MM/(INCHES)
TOLERANCES: $\pm .25/(\pm .010)$ EXCEPT WHERE NOTED

Specifications are subject to change without notice.
Customers should verify actual device performance in their specific applications.

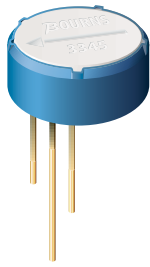

BOURNS®

3345 1/2" Round Trimming Potentiometer

Features

- Single-turn / Wirewound / Industrial / Sealed
- Industrial wirewound
- 1.0 watt power rating at 70 °C
- Available with a thumbwheel and screwdriver slot adjustment
- RoHS compliant†

Electrical Characteristics

Standard Resistance Range 10 to 50K ohms
 (see standard resistance table)
 Resistance Tolerance ±5 % std.
 (tighter tolerance available)
 Absolute Minimum Resistance 1.0 % or 0.5 ohms max.
 (whichever is greater)
 Noise 100 ohms ENR max.
 Resolution See standard resistance table
 1,000 megohms min.
 Dielectric Strength
 Sea Level 1,500 vac
 70,000 Feet 350 vac
 Insulation Resistance 500 vdc.
 100 megohms min.
 Adjustment Angle 280 ° nom.

Environmental Characteristics

Power Rating
 70 °C 1 watt
 150 °C 0 watt
 Temperature Range -55 °C to +150 °C
 Temperature Coefficient ±50 ppm/°C
 Seal Test 85 °C Fluorinert*
 Humidity MIL-STD-202 Method 106
 (1 % ΔTR, 10 megohms IR)
 Vibration 30 G (1 % ΔTR; 1 % ΔVR)
 Shock 100 G (1 % ΔTR; 1 % ΔVR)
 Load Life 1,000 hours, 1 watt @ 70 °C
 Rotational Life 200 cycles
 (2 % ΔTR; 500 ohms ENR)

Physical Characteristics

Mechanical Angle 310 ° nom.
 Torque 5.0 oz-in. max.
 Stop Strength 15 oz-in. min.
 Terminals Solderable pins
 Weight 0.04 oz.
 Marking Manufacturer's trademark,
 resistance code, wiring diagram,
 date code, manufacturer's
 model number and style
 Standard Packaging 100 pcs. per bag

*"Fluorinert" is a registered trademark of 3M Co.
 †RoHS Directive 2002/95/EC Jan 27 2003 including Annex.
 Specifications are subject to change without notice.
 Customers should verify actual device performance in
 their specific applications. REV 09/04

Product Dimensions

3345P

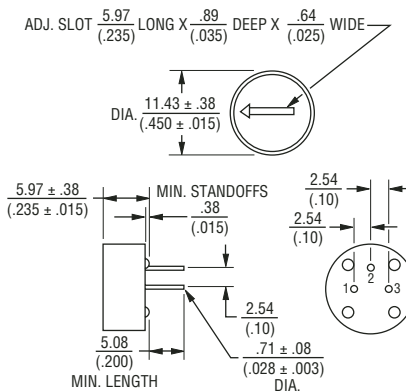

3345P THUMBWHEEL

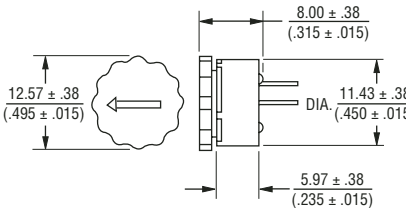

3345W

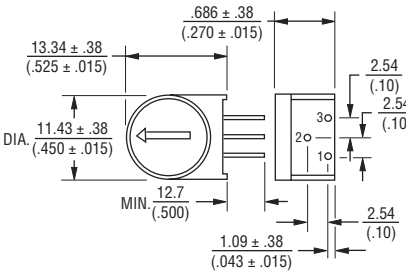

3345W THUMBWHEEL

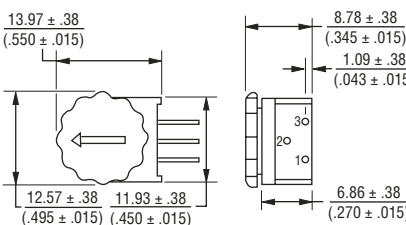

DIMENSIONS: MM/(INCHES)
 TOLERANCES: ±.25/(±.010) EXCEPT WHERE NOTED

Standard Resistance Table

Resistance (Ohms)	Resistance Code	Nominal Resolution (Percent)
10	100	0.94
20	200	0.76
50	500	0.58
100	101	0.49
200	201	0.49
500	501	0.38
1,000	102	0.30
2,000	202	0.24
5,000	502	0.18
10,000	103	0.14
20,000	203	0.13
50,000	503	0.12

Special resistances available from 10 to 50K ohms.

How To Order

3345 P - 1 - 502 T

Model _____
 Style _____
 Standard Product _____
 Resistance Code _____
 Optional Suffix Letter _____
 T = Thumb Wheel
 Consult factory for other available options.

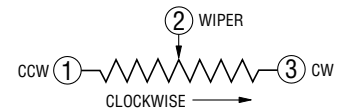

AVAILABLE THROUGH DISTRIBUTION



BOURNS®

3352 3/8" Round Trimming Potentiometer

Features

- Single-Turn / Cermet / Industrial / Open Frame
- Stable cermet element offers infinite resolution
- Very low profile
- Seven standard pin styles
- Thumb and screwdriver adjustment
- RoHS compliant*

Electrical Characteristics

Standard Resistance Range10 to 2 megohms
(see standard resistance table)
Resistance Tolerance±20 % std.
(tighter tolerance available)
Absolute Minimum Resistance2 ohms max.
Contact Resistance Variation1.0 % or 1 ohm max.
(whichever is greater)
Adjustability
Voltage±0.05 %
Resistance±0.25 %
ResolutionInfinite
Dielectric Strength
Sea Level500 vac
80,000 Feet350 vac
Adjustment Angle205° nom.

Environmental Characteristics

Power Rating (250 volts max.)
85 °C0.50 watt
125 °C0 watt
Temperature Range-55 °C to +125 °C
Temperature Coefficient
±100 ppm/°C2K & up
±150 ppm/°CBelow 2K
HumidityMIL-STD-202 Method 103
96 hours
(2 % ΔTR, 10 Megohms IR)
Vibration30 G (2 % ΔTR; 2 % ΔVR)
Shock100 G (2 % ΔTR; 2 % ΔVR)
Load Life1,000 hours 0.5 watt @ 85 °C
(3 % ΔTR)
Rotational Life200 cycles
(10 % ΔTR)

Physical Characteristics

Mechanical Angle250 ° nom.
Torque3.0 oz-in. max.
Stop Strength8 oz-in. min.
TerminalsSolderable pins
Weight0.01 oz.
MarkingManufacturer's trademark,
resistance value and model number.
Date code on packaging.
Wiper50 % (Actual TR) ±10 %
Standard Packaging100 pcs. per bag
Adjustment ToolH-90

Specifications are subject to change without notice.
*RoHS Directive 2002/95/EC Jan 27 2003 including Annex.
Customers should verify actual device performance in their specific applications. REV 09/04

Product Dimensions

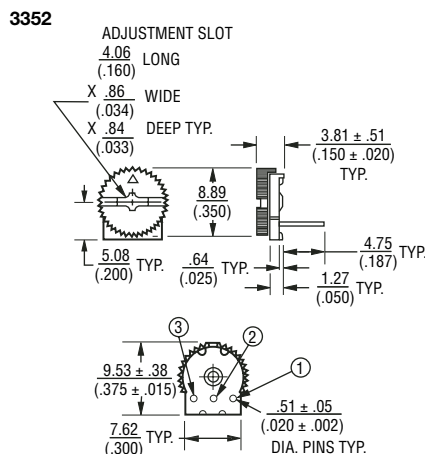

3352E Top Adjust

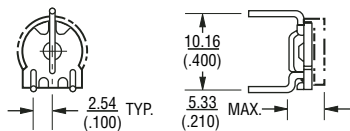

3352P

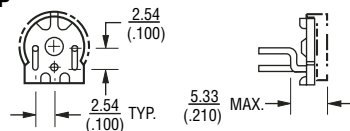

3352T

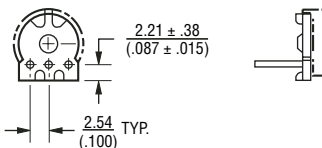

DIMENSIONS: MM/(INCHES)
TOLERANCES: ±.25/(±.010) EXCEPT WHERE NOTED

How To Order

3352 W - 1 - 103 LF

Model _____
Style _____
Standard or Modified Product Indicator _____
-1 = Standard Product
Resistance Code _____
Terminations _____
LF = 100 % Tin-plated (RoHS compliant)
Blank = 90 % Tin / 10 % Lead-plated (Standard)

Consult factory for other available options.

3352H Side Adjust

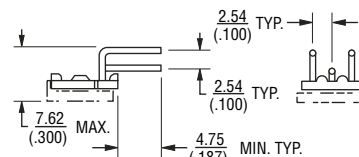

3352K

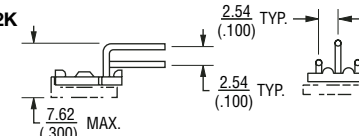

3352V

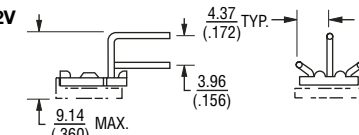

3352W

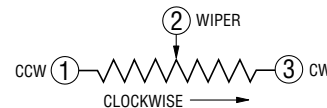
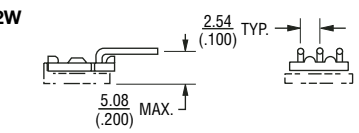

Standard Resistance Table

Resistance		Resistance	
Ohms	Code	Ohms	Code
10	100	20,000	203
20	200	25,000	253
50	500	50,000	503
100	101	100,000	104
200	201	200,000	204
500	501	250,000	254
1,000	102	500,000	504
2,000	202	1,000,000	105
5,000	502	2,000,000	205
10,000	103		

Popular distribution resistance values listed in **boldface**.
Special resistances available.

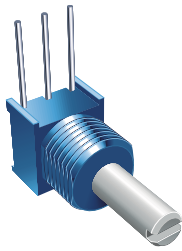

BOURNS®

3360 6 mm Square Sealed Panel Control

Features

- Conductive plastic
- Linear and audio tapers
- PC board and bushing mount
- Plastic bushing and plastic shaft
- Withstands typical industrial washing processes
- RoHS compliant* version available

Electrical Characteristics

Standard Resistance Range
 Linear.....1K ohms to 1 megohm
 Total Resistance Tolerance
 Linear Tapers±20 %
 Independent Linearity.....±5 %
 Absolute Minimum Resistance
2 ohms maximum
 Effective Electrical Angle240 ° nominal
 Contact Resistance Variation
1 ohm or 1 %
 (whichever is greater)
 Dielectric Withstanding Voltage
 (MIL-STD-202 – Method 301)
 Sea Level.....900 VAC minimum
 70,000 Feet350 VAC minimum
 Insulation Resistance
1,000 megohms minimum
 Power Rating @ 70 °C
 (Derate to 0 at 125 °C –
 Voltage Limited By Power Dissipation
 or 200 VAC, Whichever is Less)
25 watts
 Theoretical Resolution....Essentially infinite

Environmental Characteristics

Operating Temperature Range
+1 °C to +125 °C
 Storage Temperature Range
-55 °C to +125 °C
 Temperature Coefficient
 Over Storage Temperature Range
±1,000 ppm/°C
 Vibration30 G
 Total Resistance Shift ±2 % maximum
 Voltage Ratio Shift ±2 % maximum
 Shock100 G
 Total Resistance Shift±2 % maximum
 Voltage Ratio Shift±2 % maximum
 Load Life.....1,000 Hours
 Total Resistance Shift
±10 % TRS maximum
 Rotational Life (No Load)50,000 Cycles
 Total Resistance Shift
±5 % TRS maximum
 Contact Resistance Variation
3 % or 3 ohms, whichever is greater
 Moisture Resistance
 MIL-STD-303, Method 103, Condition B
 Total Resistance Shift
±10 % TRS maximum
 IP RatingIP 67

Mechanical Characteristics

Stop Strength.....5.65 N-cm (8 oz.-in.)
 Mechanical Angle310 ° nominal
 Torque
 Starting
3.53 N-cm (5.0 oz.-in.) maximum
 Running
3.53 N-cm (5.0 oz.-in.) maximum
 Mounting (Torque on Bushing)
17 N-cm (1.5 lb.-in.) maximum
 [plastic bushing]
 Weight (Single Section).....4.5 grams
 TerminalsSolderable pins
 Soldering Condition
5 seconds at 360 °C maximum.
 Recommended hand soldering
 using Sn95/Ag5 no clean solder,
 0.025 wire diameter.
 Marking.....Manufacturer's trademark,
 model number, product code,
 terminal style, resistance code
 and date code
 Ganging.....1 cup maximum
 Hardware.....One lockwasher
 and one mounting nut
 is shipped with each potentiometer,
 except where noted in the part number.
 Flammability.....Conforms to UL94V-0
 Epoxy.....Conforms to UL94V-1

Standard Resistance Table

Resistance (Ohms)	Resistance Code
1,000	102
2,000	202
5,000	502
10,000	103
20,000	203
50,000	503
100,000	104
200,000	204
500,000	504
1,000,000	105

Popular distribution values listed in **boldface**.
 Special resistances available.

How To Order

3360 Y - 1 103 LF

Model _____
 Terminal Style Designator _____
 Single Cup: _____
 C = In-line Straight
 Terminals Side Exit
 P = 5.08 mm x 2.54 mm
 Triangular Pattern
 Rear Exit
 Y = 5.08 mm x 5.08 mm
 Triangular Pattern
 Rear Exit
 Bushing Designator _____
 1 = Standard
 Resistance Code _____
 Terminations _____
 LF = 100 % Tin-plated (RoHS compliant)
 Blank = 90 % Tin / 10 % Lead-plated
 (Standard)

Trimmer Data Sheets

Specifications are subject to change without notice.
 *RoHS Directive 2002/95/EC Jan 27 2003 including Annex.
 Customers should verify actual device performance in
 their specific applications. REV 09/04

3360 – Product Dimensions

COMMON DIMENSIONS 3360C

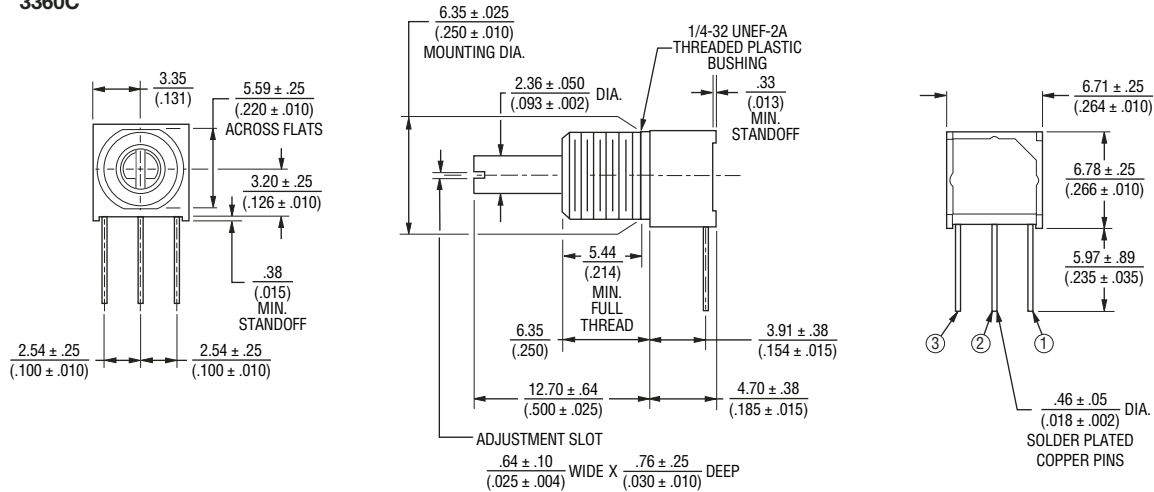

3360P

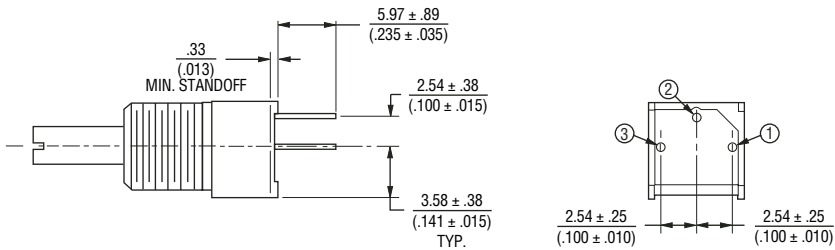

3360Y

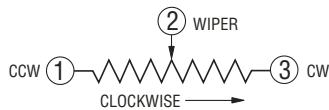
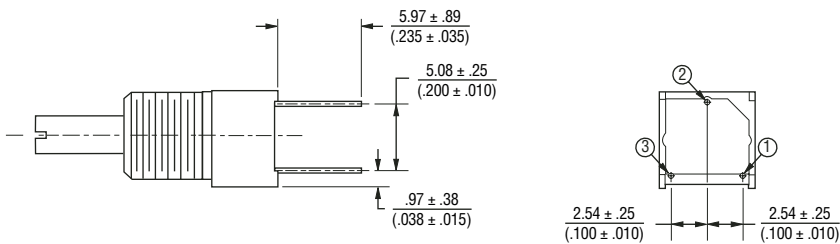

DIMENSIONS: MM/(INCHES)

Specifications are subject to change without notice. Customers should verify actual device performance in their specific applications.

AVAILABLE THROUGH DISTRIBUTION

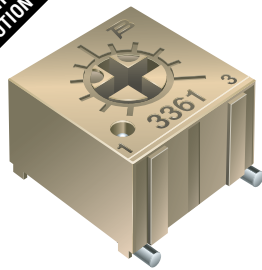

BOURNS®

3361 1/4" Square SMD Trimming Potentiometer

Features

- Single-Turn / Cermet / Industrial / Sealed
- Miniature package
- Rotor designed for automatic machine adjust interface
- Withstands harsh environments and immersion cleaning processes
- Compatible with surface mount manufacturing processes
- RoHS compliant† version available – See page 155 for processing information on lead free surface mount trimmers

Electrical Characteristics

Standard Resistance Range 10 to 2 megohms (see standard resistance table)
 Resistance Tolerance ±10 % std. (tighter tolerance available)
 Absolute Minimum Resistance 1 % or 2 ohms (whichever is greater)
 Contact Resistance Variation 1 % or 3 ohms max. (whichever is greater)
 Adjustability
 Voltage ±0.05 %
 Resistance ±0.15 %
 Resolution Infinite
 Insulation Resistance 500 vdc. 1,000 megohms min.
 Dielectric Strength
 Sea Level 900 vac
 80,000 Feet 350 vac
 Adjustment Angle 240 ° nom.

Environmental Characteristics

Maximum Soldering Exposure (Temp/Time) +245 °C/10 Sec.
 Power Rating (300 volts max.)
 70 °C 0.50 watt
 125 °C 0 watt
 Temperature Range -55 °C to +125 °C
 Temperature Coefficient ±100 ppm/°C
 Seal Test 85 °C Fluorinert*
 Humidity MIL-STD-202 Method 103 96 hours (2 % ΔTR; 10 Megohms IR)
 Vibration 30 G (1 % ΔTR; 1 % ΔVR)
 Shock 100 G (1 % ΔTR; 1 % ΔVR)
 Load Life 1,000 hours 0.5 watt @ 70 °C (3 % ΔTR; 3 % or 3 ohms, whichever is greater, CRV)
 Rotational Life 200 cycles (4 % ΔTR; 3 % or 3 ohms, whichever is greater, CRV)

Physical Characteristics

Mechanical Angle 270 ° nom.
 Torque 3.0 oz-in. max.
 Stop Strength 7.0 oz -in. min.
 Terminals Solderable pins
 Weight 0.02 oz.
 Marking Resistance code, terminal numbers, manufacturer's model number, style and date code
 Wiper 50 % (Actual TR) ±10 %
 Flammability U.L. 94V-0
 Standard Packing
 "S" Style 500 pcs./13" reel
 "P" Style 750 pcs./13" reel
 Adjustment Tool H-90

Product Dimensions

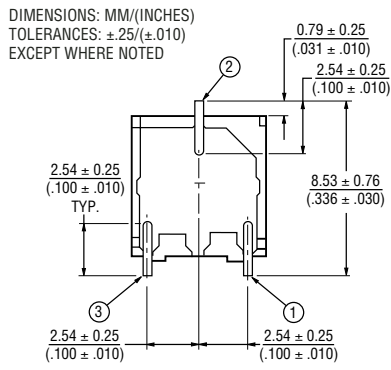
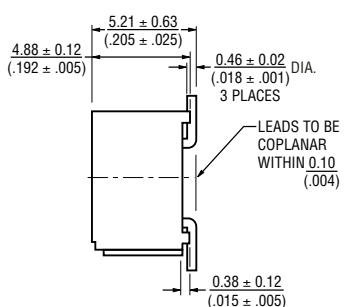
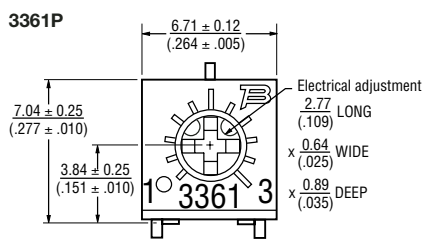

Recommended Land Pattern

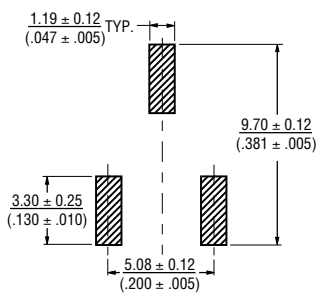

*"Fluorinert" is a registered trademark of 3M Co.
 †RoHS Directive 2002/95/EC Jan 27 2003 including Annex. Specifications are subject to change without notice. Customers should verify actual device performance in their specific applications.
 REV 09/04

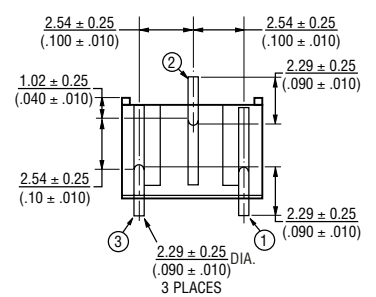
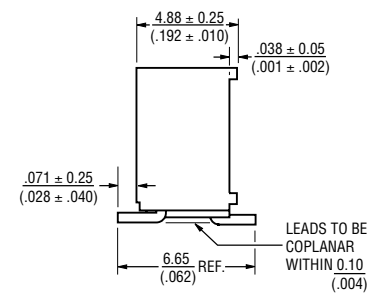
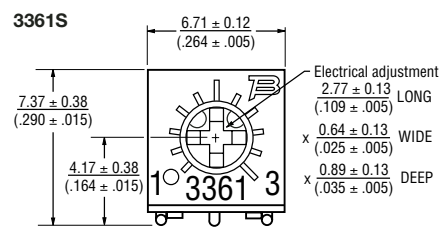

Recommended Land Pattern

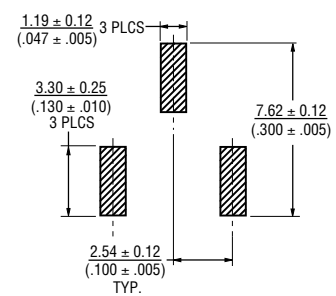

Trimmer Data Sheets

3361 – Packaging Specifications and Ordering Information

Packaging Specifications

P Style

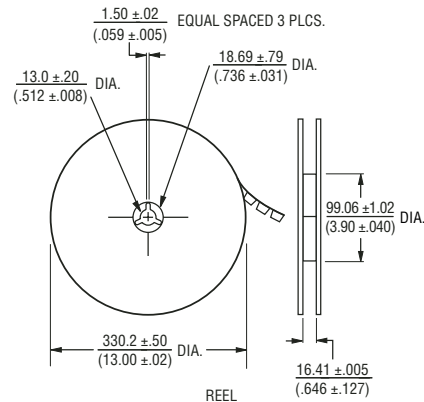
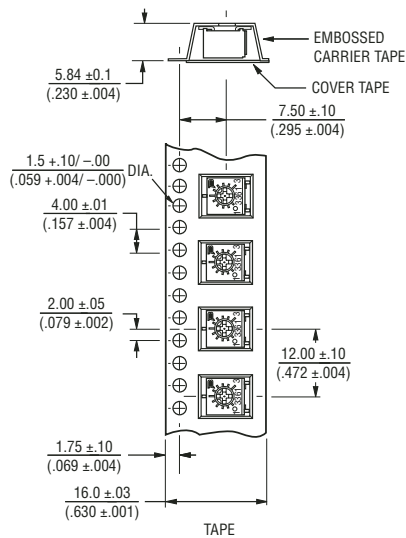

Units packaged 750 pieces per reel.

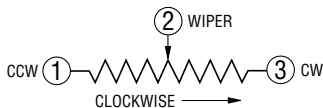

S Style

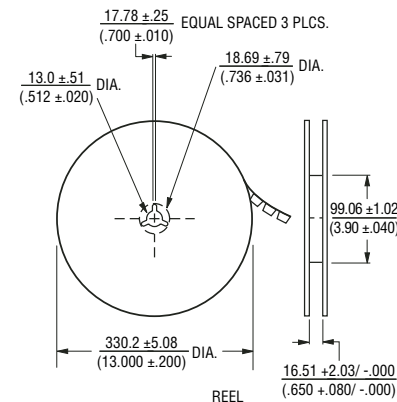
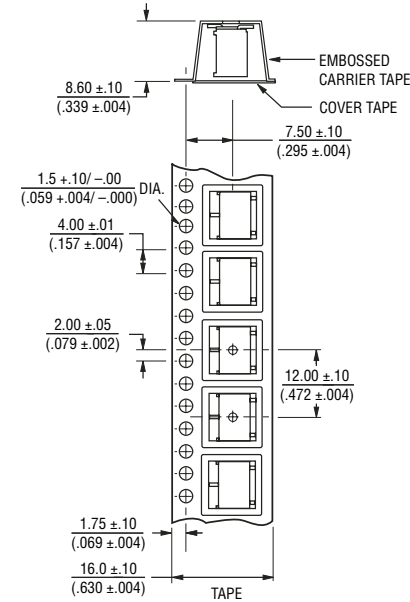

Units packaged 500 pieces per reel.

Standard Resistance Table

Resistance (Ohms)	Resistance Code
10	100
20	200
50	500
100	101
200	201
500	501
1,000	102
2,000	202
5,000	502
10,000	103
20,000	203
25,000	253
50,000	503
100,000	104
200,000	204
250,000	254
500,000	504
1,000,000	105
2,000,000	205

Popular distribution resistance values listed in **boldface**. Special resistances available.

How To Order

3361 P - 1 - 502 G LF

Model _____
 Style _____
 Standard or Modified _____
 Product Indicator _____
 -1 = Standard Product
 Resistance Code _____
 Packaging Designator _____
 G = Embossed Tape
 "S" Style = 500 pcs./13" reel
 "P" Style = 750 pcs./13" reel
 Terminations _____
 LF = 100 % Tin-plated (RoHS compliant)
 Blank = 90 % Tin / 10 % Lead-plated (Standard)
 Consult factory for other available options.

Specifications are subject to change without notice. Customers should verify actual device performance in their specific applications.

AVAILABLE THROUGH DISTRIBUTION

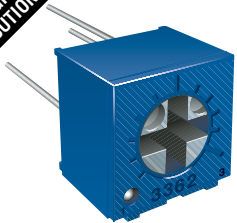

BOURNS®

3362 1/4" Square SMD Trimming Potentiometer

Features

- Single-Turn / Cermet / Industrial / Sealed
- Miniature package
- Rotor designed for automatic machine adjust interface
- Withstands harsh environments and immersion cleaning processes
- Available with a knob for finger adjust
- Available on tape and reel packaging
- RoHS compliant* version available

Electrical Characteristics

Standard Resistance Range 10 to 2 megohms (see standard resistance table)
 Resistance Tolerance ±10 % std. (tighter tolerance available)
 Absolute Minimum Resistance 1 % or 2 ohms (whichever is greater)
 Contact Resistance Variation 1 % or 3 ohms max. (whichever is greater)
 Adjustability
 Voltage ±0.05 %
 Resistance ±0.15 %
 Resolution Infinite
 Insulation Resistance 500 vdc. 1,000 megohms min.
 Dielectric Strength
 Sea Level 900 vac
 80,000 Feet 350 vac
 Adjustment Angle 240 ° nom.

Environmental Characteristics

Power Rating (300 volts max.)
 70 °C 0.50 watt
 125 °C 0 watt
 Temperature Range -55 °C to +125 °C
 Temperature Coefficient ±100 ppm/°C
 Seal Test 85 °C Fluorinert*
 Humidity MIL-STD-202 Method 103 96 hours (2 % ΔTR; 10 Megohms IR)
 Vibration 30 G (1 % ΔTR; 1 % ΔVR)
 Shock 100 G (1 % ΔTR; 1 % ΔVR)
 Load Life 1,000 hours 0.5 watt @ 70 °C (3 % ΔTR; 3 % or 3 ohms, whichever is greater, CRV)
 Rotational Life 200 cycles (4 % ΔTR; 3 % or 3 ohms, whichever is greater, CRV)

Physical Characteristics

Mechanical Angle 270 ° nom.
 Torque 3.0 oz-in. max.
 Stop Strength 7.0 oz -in. min.
 Terminals Solderable pins
 Weight 0.02 oz.
 Marking Resistance code, terminal numbers, manufacturer's model number, style and date code
 Wiper 50 % (Actual TR) ±10 %
 Flammability U.L. 94V-0
 Standard Packaging 50 pcs. per tube
 Adjustment Tool H-90

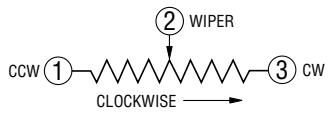

Product Dimensions

Common Dimensions Top Adjust

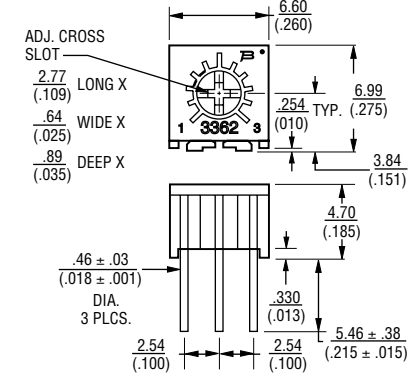

3362H

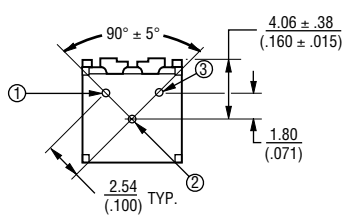

3362P

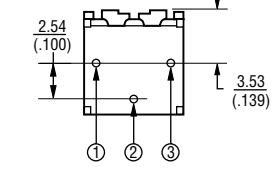

3362R

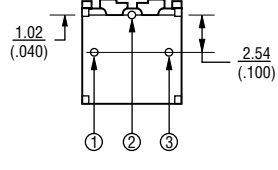

3362Z

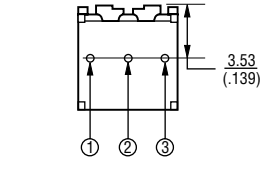

DIMENSIONS: MM/(INCHES)
 TOLERANCES: ±.25/(±.010) EXCEPT WHERE NOTED

Common Dimensions Side Adjust

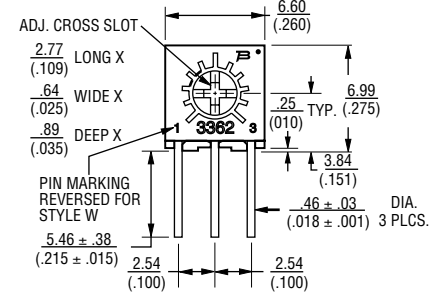

3362M

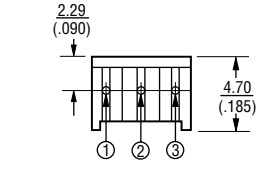

3362S

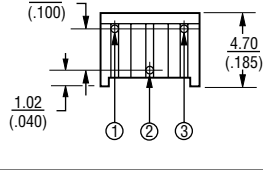

3362W

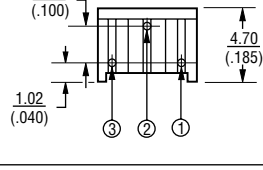

3362X

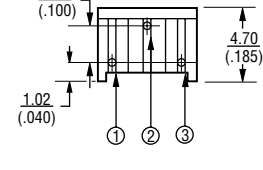

3362Z

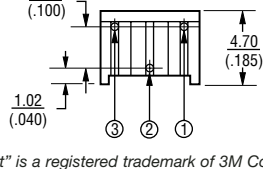

*"Fluorinert" is a registered trademark of 3M Co.
 *RoHS Directive 2002/95/EC Jan 27 2003 including Annex. Specifications are subject to change without notice. Customers should verify actual device performance in their specific applications. REV 09/04

Trimmer Data Sheets

3362 – Product Dimensions, Packaging Specifications and Ordering Information

Product Dimensions

The Model 3362P is available with a knob for finger adjustment. Add suffix letter "T" to order code.

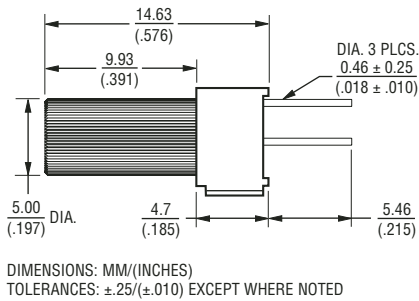
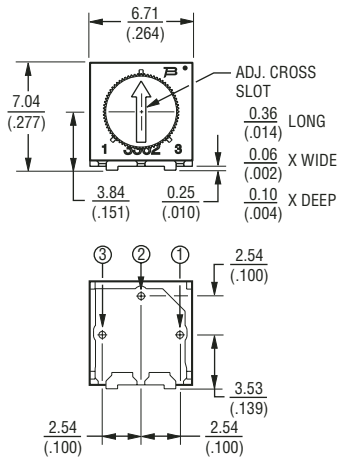

DIMENSIONS: MM/(INCHES)
TOLERANCES: $\pm .25/(\pm .010)$ EXCEPT WHERE NOTED

Packaging Specifications

SIDE ADJUST 3362M-1

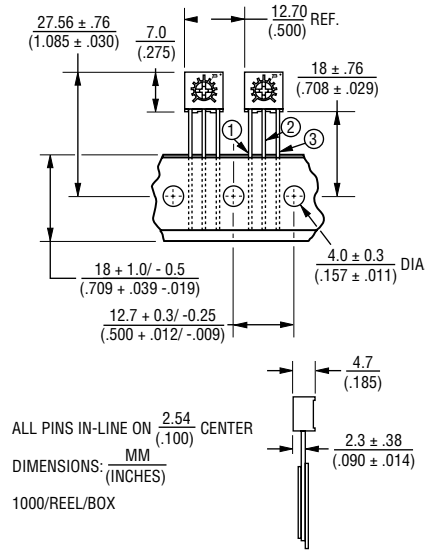

ALL PINS IN-LINE ON $\frac{2.54}{(.100)}$ CENTER
DIMENSIONS: $\frac{\text{MM}}{(\text{INCHES})}$
1000/REEL/BOX

TOP ADJUST 3362U-1, 3362P-1

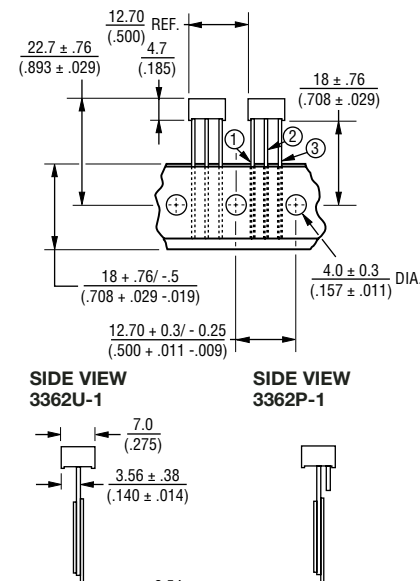

SIDE VIEW 3362U-1
SIDE VIEW 3362P-1

ALL PINS IN-LINE ON $\frac{2.54}{(.100)}$ CENTER
DIMENSIONS: $\frac{\text{MM}}{(\text{INCHES})}$
750/REEL
1000/BOX

Meets EIA Specification 468.

Standard Resistance Table

Resistance (Ohms)	Resistance Code
10	100
20	200
50	500
100	101
200	201
500	501
1,000	102
2,000	202
5,000	502
10,000	103
20,000	203
25,000	253
50,000	503
100,000	104
200,000	204
250,000	254
500,000	504
1,000,000	105
2,000,000	205

Popular distribution resistance values listed in **boldface**.
Special resistances available.

How To Order

3362 P - 1 - 502 T LF

Model _____
Style _____
Standard or Modified Product Indicator _____
-1 = Standard Product
Resistance Code _____
Optional Suffix Letter _____
T = Knob*
Packaging Designator _____
Blank = Tube (Standard)
R = Tape and Reel (M, U and P Pin Styles Only)
A = Ammo Pack (M, U and P Pin Styles Only)
Terminations _____
LF = 100 % Tin-plated (RoHS compliant)
Blank = 90 % Tin / 10 % Lead-plated (Standard)

*Knob option is available only in standard Tube packaging for terminal style P.
Consult factory for other available options.

Specifications are subject to change without notice.
Customers should verify actual device performance in their specific applications.

AVAILABLE THROUGH DISTRIBUTION

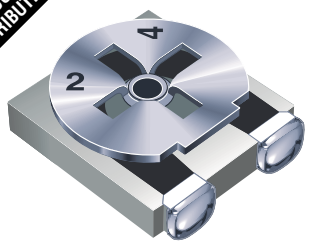

BOURNS®

3364 4 mm Square Trimming Potentiometer

Features

- SMD Single-Turn / Cermet / Industrial Open Frame
- Cross slot rotor designs suitable for automatic adjustment equipment
- Supplied in 12 mm embossed tape, compatible with automatic pick-and-place assembly equipment
- Recommended for reflow solder processing only
- RoHS compliant† – See page 155 for processing information on lead free surface mount trimmers

Electrical Characteristics

Standard Resistance Range
100 ohms to 1 megohm
 (see standard resistance table)
 Resistance Tolerance.....±25 % std.
 End Resistance
 <1K.....20 ohms max.
 >1K.....2 %
 Contact Resistance Variation
 (Voltage Divider).....5 % max.
 Resolution.....Infinite
 Adjustment Angle.....260 °±20 °

Environmental Characteristics

Power Rating (50 volts max.)
 70 °C.....0.2 watt
 Temperature Range.....-40 °C to +100 °C
 Temperature Coefficient..... ±250 ppm/°C
 Humidity.....500 hours (5 % ΔTR)
 Load Life.....500 hours
 0.2 watt @ 70 °C (5 % ΔTR)
 Rotational Life.....20 cycles (15% ΔTR)

Physical Characteristics

Torque.....20 to 200 g-cm
 Mechanical Angle.....Continuous
 Marking.....Resistance code, manufacturer's full part number and date code on packaging
 Terminals.....Solder coated
 Standard Packaging.....1000 pcs./7 " reel
 Adjustment Tool.....H-90
 Reflow solder processing recommended

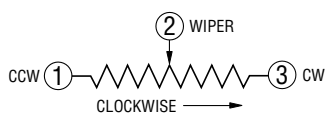

Product Dimensions

Common Dimensions
3364W, X
3-Terminal

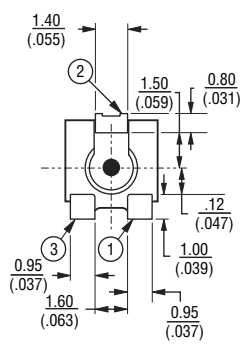
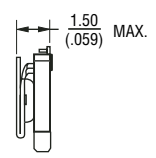
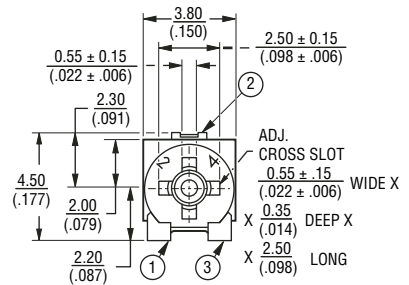

SUGGESTED PWB LAYOUT

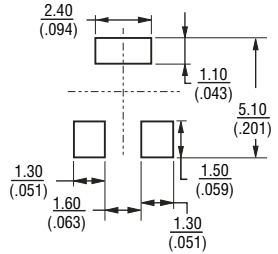

DIMENSIONS: MM/(INCHES)
 TOLERANCES: ±.25(±.010) EXCEPT WHERE NOTED

3364A, B
3-Terminal

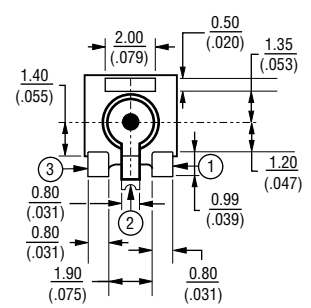
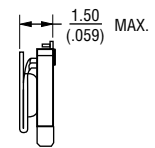
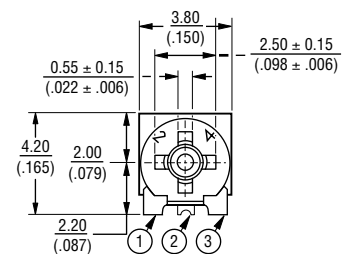

SUGGESTED PWB LAYOUT

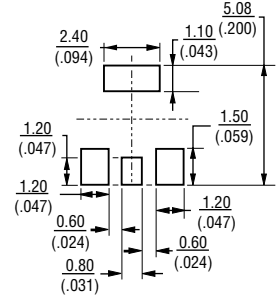

Specifications are subject to change without notice.
 †RoHS Directive 2002/95/EC Jan 27 2003 including Annex.
 Customers should verify actual device performance in their specific applications.
 REV 09/04

Trimmer Data Sheets

3364 – Packaging Specifications and Ordering Information

Packaging Specifications

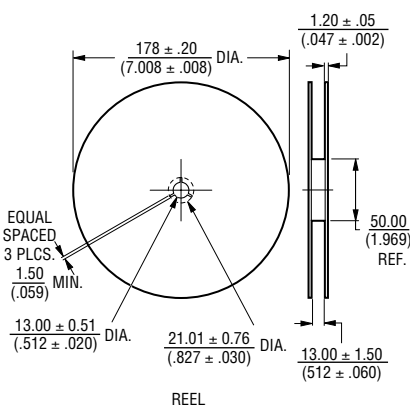
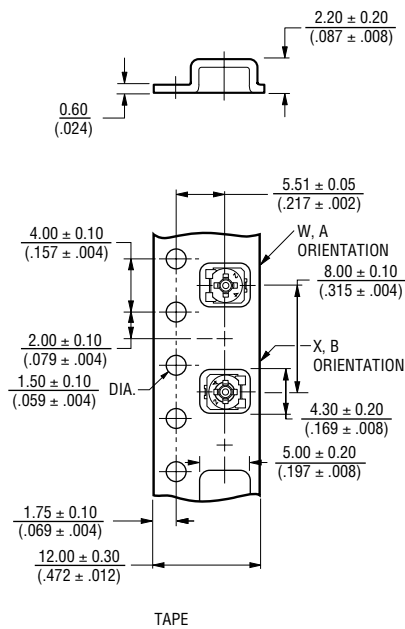

Conforms with EIA specification RS-481.

Standard Resistance Table

Resistance (Ohms)	Resistance Code	Part Marking
100	101	12
200	201	22
500	501	52
1,000	102	13
2,000	202	23
5,000	502	53
10,000	103	14
20,000	203	24
50,000	503	54
100,000	104	15
200,000	204	25
500,000	504	55
1,000,000	105	16

Popular distribution resistance values listed in **boldface**.
Special resistances available.

How To Order

Model 3364 X - 1 - 103 E

Style _____

Orientation of parts in tape:
W,A = Terminals toward sprocket holes
X,B = Terminals away from sprocket holes

Standard Product _____

Resistance Code _____

Embossed Tape Designator _____
E = 1000 pcs./7" reel (-1 standard)
G = 5000 pcs./14.5" reel (-1 optional)

Consult factory for other available options.

Specifications are subject to change without notice.
Customers should verify actual device performance in their specific applications.

AVAILABLE THROUGH DISTRIBUTION

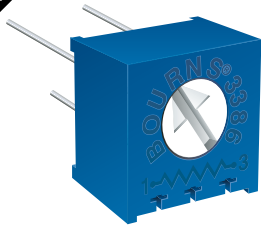

BOURNS®

3386 3/8" Square Trimming Potentiometer

Features

- Single Turn / Cermet / Industrial / Sealed
- Available on tape and reel
- Available with a knob for finger adjust
- Available with extended shaft
- Available with cross-slot rotor
- Top and side adjust types (F, P, H, W, X most popular)
- High voltage types available (see page 88)
- RoHS compliant* version available

Electrical Characteristics

Standard Resistance Range10 to 2 megohms
	(see standard resistance table)
Resistance Tolerance±10 % std.
	(tighter tolerance available)
Absolute Minimum Resistance2 ohms max.
Contact Resistance Variation2 % or 3 ohms max.
	(whichever is greater)
Adjustability	
Voltage±0.05 %
Resistance±0.15 %
ResolutionInfinite
Insulation Resistance500 vdc.
	1,000 megohms min.
Dielectric Strength	
Sea Level900 vac
70,000 Feet350 vac
Adjustment Angle280 ° nom.

Environmental Characteristics

Power Rating (300 volts max.)	
85 °C0.5 watt
125 °C0 watt
Temperature Range-55 °C to +125 °C
Temperature Coefficient±100 ppm/°C
Seal Test85 °C Fluorinert*
HumidityMIL-STD-202 Method 103
	96 hours (2 % ΔTR; 10 Megohms min.)
Vibration30 G (1 % ΔTR; 1 % ΔVR)
Shock100 G (1 % ΔTR; 1 % ΔVR)
Load Life1,000 hours 0.5 watt @ 70 °C
	(3 % ΔTR; 1 % or 1 ohm, whichever is greater, CRV)
Rotational Life200 cycles
	(4 % ΔTR; 1 % or 1 ohm, whichever is greater, CRV)

Physical Characteristics

Mechanical Angle310 ° nom.
Torque5.0 oz-in. max.
Stop Strength15.0 oz-in. min.
TerminalsSolderable pins
Weight0.03 oz.
MarkingManufacturer's trademark, resistance code, wiring diagram, date code, manufacturer's model number and style
FlammabilityU.L. 94V-0
Standard Packaging50 pcs. per tube
Wiper50 % (Actual TR) ±10 %
Adjustment ToolH-90

Product Dimensions

Common Dimensions Side Adjust

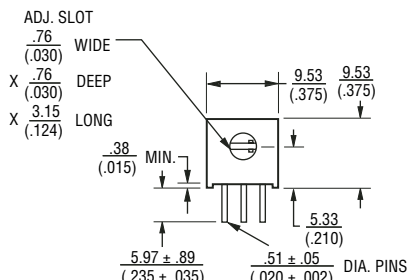

3386B

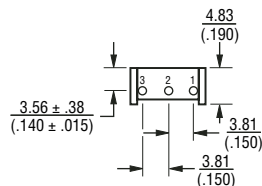

3386C

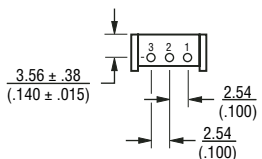

3386H

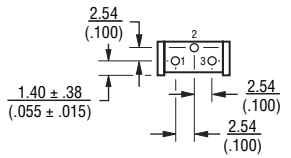

3386J

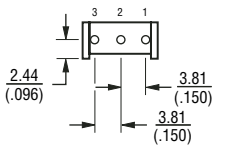

3386S

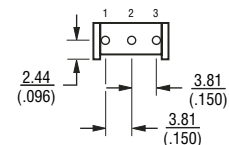

3386W

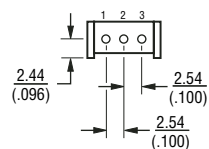

3386X

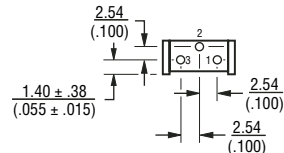

DIMENSIONS: MM/(INCHES)
TOLERANCES: ±.25/(±.010) EXCEPT WHERE NOTED

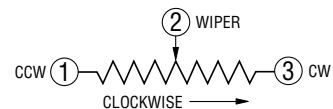

*"Fluorinert" is a registered trademark of 3M Co.
*RoHS Directive 2002/95/EC Jan 27 2003 including Annex. Specifications are subject to change without notice. Customers should verify actual device performance in their specific applications. REV 09/04

3386 – Product Dimensions

Common Dimensions Top Adjust

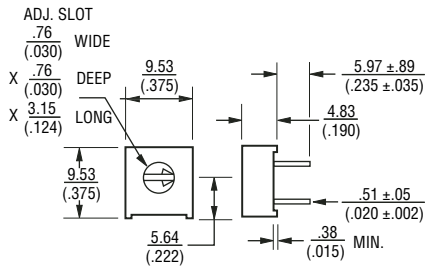

3386F

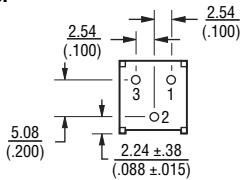

3386K

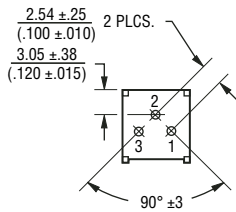

3386M

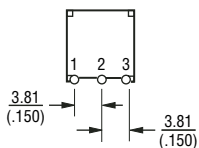

3386P

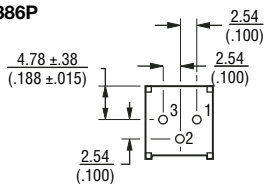

3386R

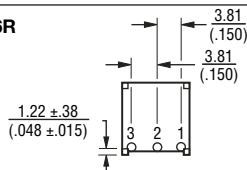

3386T

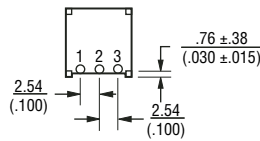

3386U

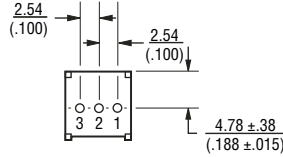

3386Y

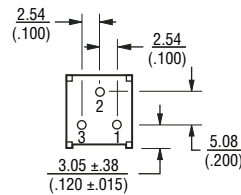

3386G

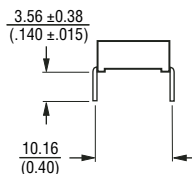
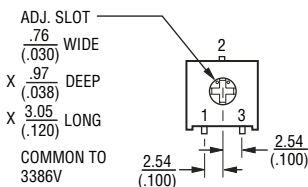

3386V

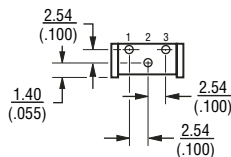
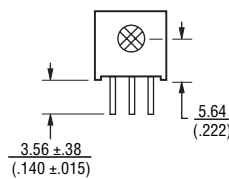

3386H-EY5 3386X-EY5 – SHOWN

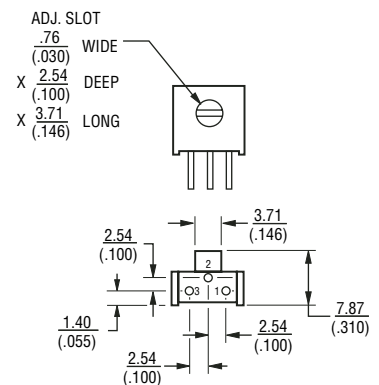

3386P-EY5

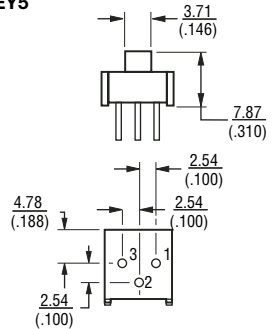

The Model 3386 is available with a knob for finger adjustment. Add suffix letter "T" to order code for F, P and X terminal styles.

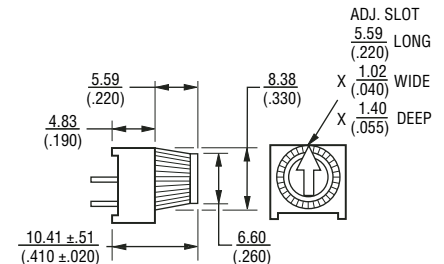

DIMENSIONS: MM/(INCHES)
 TOLERANCES: $\pm .25$ ($\pm .010$) EXCEPT WHERE NOTED

Specifications are subject to change without notice.
 Customers should verify actual device performance in their specific applications.

3386 – Packaging Specifications and Ordering Information

Packaging Specifications

SIDE ADJUST 3386W-1

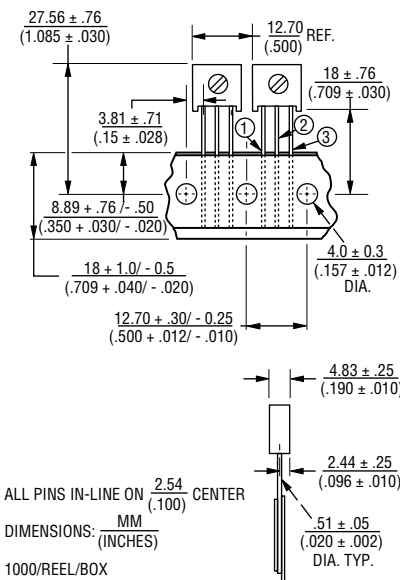

Meets EIA Specification 468.

TOP ADJUST 3386U-1

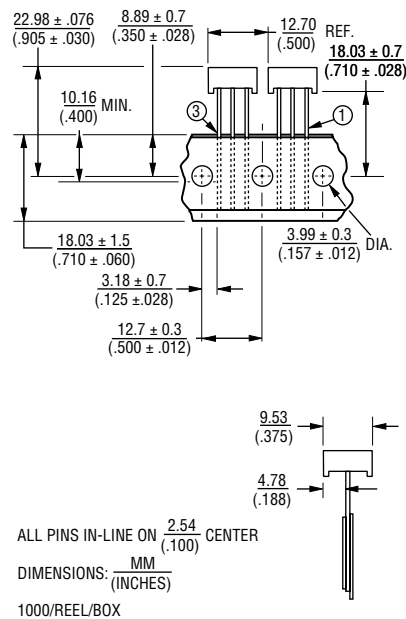

Meets EIA Specification 468.

Standard Resistance Table

Resistance (Ohms)	Resistance Code
10	100
20	200
50	500
100	101
200	201
500	501
1,000	102
2,000	202
5,000	502
10,000	103
20,000	203
25,000	253
50,000	503
100,000	104
200,000	204
250,000	254
500,000	504
1,000,000	105
2,000,000	205

Popular distribution resistance values listed in **boldface**.
Special resistances available.

How To Order

3386 P - 1 - 103 T LF

Model _____
 Style _____
 Standard or Modified _____
 Product Indicator _____
 -1 = Standard Product
 -EY5 = Extended Shaft
 Resistance Code _____
 Optional Suffix Letter _____
 T = Knob*
 Packaging Designator _____
 Blank = Tube (Standard)
 R = Tape and Reel
 (W and U Pin Styles Only)
 A = Ammo Pack
 (W and U Pin Styles Only)
 Terminations _____
 LF = 100 % Tin-plated (RoHS compliant)
 Blank = 90 % Tin / 10 % Lead-plated
 (Standard)

*Knob option is available only
in standard Tube packaging
Consult factory for other available options.

Specifications are subject to change without notice.
Customers should verify actual device performance in
their specific applications.

3386-HV2 / 3386-HV3 3/8" Trimming Potentiometer

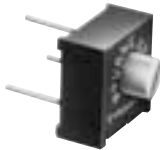

BOURNS®

Features

- 3/8" Square / Single-Turn / Cermet Industrial / Sealed High Voltage Focus Control
- Designed for electrostatic focus control applications on monochrome or color CRTs
- Rated at 1 KV D.C. and 600 VDC input voltage
- High stability cermet element
- Available with optional red knob
- RoHS compliant* version available

Electrical Characteristics

Standard Resistance Range2.5 and 5 megohms
 Resistance Tolerance±20 %
 Contact Resistance Variation2 % max.
 Adjustability
 Voltage Divider±0.05 %
 Rheostat±0.15 %
 ResolutionInfinite
 Insulation Resistance @ 1 KV D.C.
1,000 megohms min.
 Dielectric Strength (5,000 foot altitude)
1.5 KV A.C. min.
 Adjustment Angle280 ° nom.

Environmental Characteristics

HV2 Input Voltage
 85 °C(1K VDC max.)
 125 °C0 watt
 HV3 Input Voltage
 85 °C(600 VDC max.)
 125 °C0 watt
 Temperature Range.....-55 °C to +125 °C
 Temperature Coefficient±400 ppm/°C
 Humidity.....MIL-STD-202 Method 103
 240 Hours (100 megohms min. IR)
 Load Life
 HV2.....1,000 hours 1 KVDC
 60 °C, 90 % R.H. (3 % max. ΔTR)
 HV31,000 hours 600 VDC
 60 °C, 90 % R.H. (3 % max. ΔTR)
 Voltage Breakdown
 (5,000 foot altitude).....1.5 KV min.
 Seal Test85 °C Fluorinert*
 VibrationNo discontinuity 30 G
 ShockNo discontinuity 100 G
 Rotational Life.....200 cycles min.

Physical Characteristics

Mechanical Angle310 ° nom.
 Torque5.0 oz-in. max.
 Stop Strength.....15.0 oz -in. min.
 TerminalsSolderable pins
 Weight0.04 oz.
 MarkingManufacturer's trademark,
 resistance code, wiring diagram,
 date code, manufacturer's model
 number and style
 FlammabilityU.L. 94V-0
 Standard Packaging50 pcs. per tube
 Adjustment ToolH-90

*"Fluorinert" is a registered trademark of 3M Co.
 *RoHS Directive 2002/95/EC Jan 27 2003 including Annex.
 Specifications are subject to change without notice.
 Customers should verify actual device performance in
 their specific applications. REV 05/04

Product Dimensions

3386N Common Dimensions

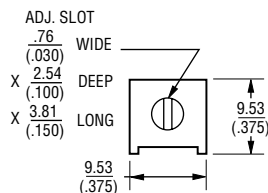
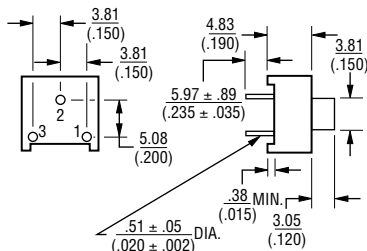

3386U

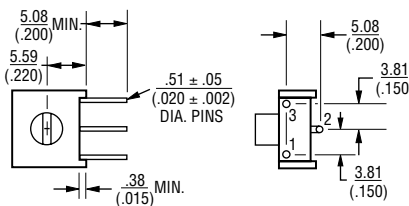

How To Order

3386 N - HV2 - 505 T LF

Model _____
 Style _____
 High Voltage _____
 Construction Indicator
 -HV2 = 1000 VDC
 -HV3 = 600 VDC
 Resistance Code _____
 -255 = 2.5 megohms
 -505 = 5 megohms
 Optional Suffix Letter _____
 T = Red Knob
 Terminations
 LF = 100 % Tin-plated (RoHS compliant)
 Blank = 90 % Tin / 10 % Lead-plated
 (Standard)

Typical Focus Control Circuits

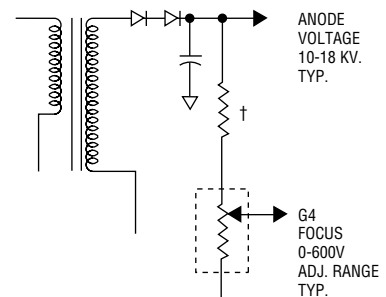

3386N-HV3-255
 or
 3386U-HV3-255

MONOCHROME

† VALUES DETERMINED BY CIRCUIT VOLTAGES

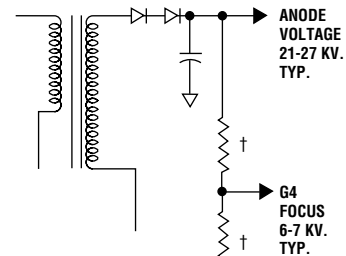

0-1 KV.
 FOCUS
 RANGE

3386N-HV2-505
 or
 3386U-HV2-505

COLOR

DIMENSIONS: MM/(INCHES)
 TOLERANCES: ±.25/(±.010) EXCEPT WHERE NOTED

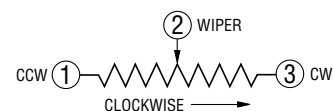

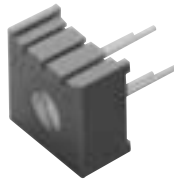

BOURNS®

3386-OT1

3/8" Square Trimming Potentiometer

Features

- Single-Turn / Cermet / Industrial / Sealed
- Designed for operational amplifier offset voltage adjustment applications
- Reduces power supply drift errors
- Unique center tapped trimming potentiometer
- Vertical adjust type available
- RoHS compliant* version available

Electrical Characteristics

Standard Resistance Range100 ohms to 1 megohm
 (see standard resistance table)
 Resistance Tolerance±20 % std.
 Absolute Minimum Resistance2 ohms max.
 Voltage Output Variation±0.25 %
 Adjustability (VR)±0.025 %
 Insulation Resistance @ 500 vdc
 1,000 megohms min.
 Dielectric Strength
 Sea Level900 vac
 70,000 Feet350 vac
 Effective Electrical Travel280 ° nom.
 Center Tap Resistance2 ohms max.
 Center Tap Electrical Center±5 %
 Center Tap Dead Band6 °±4 °

Environmental Characteristics

Power Rating
 85 °C0.5 watt
 150 °C0 watt
 Temperature Range-55 °C to +150 °C
 Temperature Stability (ΔVR)±0.5 % max.
 Seal Test85 °C Fluorinert*
 HumidityMIL-STD-202 Method 103
 96 hours ±2 %
 ΔTR 10 Megohms min.
 Vibration, 30 G±1 % ΔTR
 Shock, 100 G±1 % ΔTR
 Load Life, 1,000 Hours±3% ΔTR
 Rotational Life, 200 cycles±4% ΔTR

Physical Characteristics

Mechanical Angle310 ° nom.
 Torque5.0 oz-in. max.
 Stop Strength15.0 oz-in. min.
 TerminalsSolderable pins
 Weight0.03 oz.
 MarkingManufacturer's trademark,
 resistance code, wiring diagram,
 date code, manufacturer's model
 number and style
 FlammabilityU.L. 94V-0
 Standard Packaging
50 pcs. per tube/tray
 Adjustment ToolH-90

Also see Model 3296-OT1.

Product Dimensions

3386P-OT1

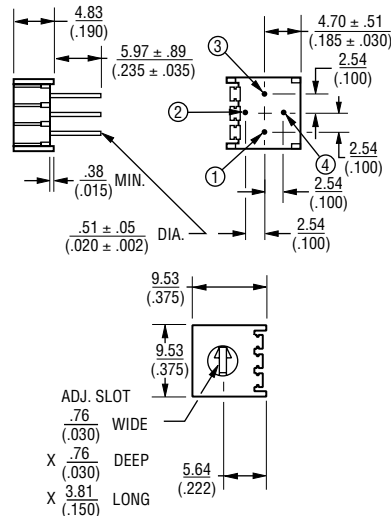

DIMENSIONS: MM/(INCHES)
 TOLERANCES: ±.25/(±.010) EXCEPT WHERE NOTED

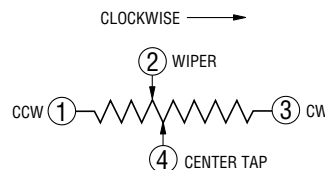

Standard Resistance Table

Resistance (Ohms)	Resistance Code
100	101
200	201
500	501
1,000	102
2,000	202
5,000	502
10,000	103
20,000	203
50,000	503
100,000	104
200,000	204
500,000	504
1,000,000	105

Popular distribution resistance values listed in **boldface**. Special resistances available. Non-boldface items are typically not stocked by distributors and are not recommended for new designs.

How To Order

3386 P - OT1 - 103 LF

Model _____
 Style _____
 Catalog Product _____
 Resistance Code _____
 Terminations
 LF = 100 % Tin-plated (RoHS compliant)
 Blank = 90 % Tin / 10 % Lead-plated (Standard)

Suggested Offset Voltage Adjustment Circuit

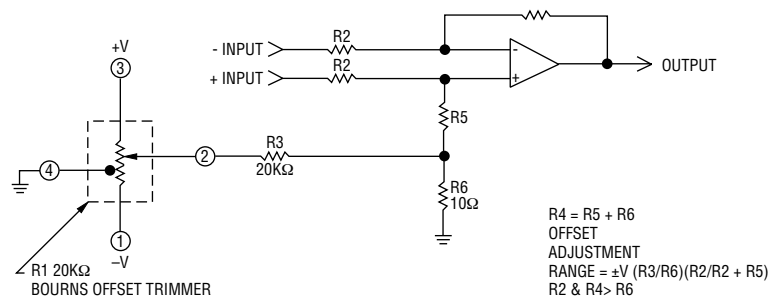

*"Fluorinert" is a registered trademark of 3M Co.
 *RoHS Directive 2002/95/EC Jan 27 2003 including Annex.
 Specifications are subject to change without notice.
 Customers should verify actual device performance in their specific applications.
 REV 05/04

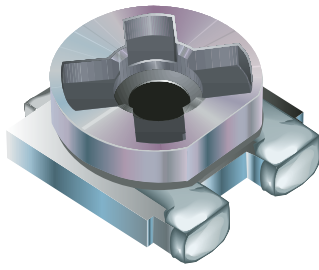

TC03 Trimming Potentiometer

Features

- High temperature plastic rotor
- Recommended for reflow processing
- Rotor design compatible with pick and place and automatic adjustment equipment
- Supplied in 8 mm embossed tape, compatible with automatic assembly equipment
- RoHS compliant* – See page 155 for processing information on lead free surface mount trimmers

BOURNS®

Electrical Characteristics

Standard Resistance Range100 to 1 megohm
 (see standard resistance table)
 Resistance Tolerance±25 % std.
 Absolute Minimum Resistance
 ≤ 1K Ohms20 ohms max.
 >1K Ohms2 % max. of TR
 Contact Resistance Variation5 % max.
 ResolutionInfinite
 Adjustment Angle270 ° ±20 °

Environmental Characteristics

Power Rating (50 VDC max.)
 70 °C0.10 watt
 Temperature Range.....-40 °C to +85 °C
 Temperature Coefficient±250 ppm/°C
 Humidity95 %RH
 500 hours
 TRS max.±5 %
 Load Life
@ 70 °C rated power 500 hours
 TRS ±5 %
 Rotational Cycling.....20 turns
 TRS ±15 %

Physical Characteristics

Torque20-200 g-cm max.
 Mechanical AngleContinuous
 Marking.....Part marking code
 Standard Packaging.....2000 pcs./7 " reel

Product Dimensions

TC03X-2
3 mm Open Frame
for Reflow Soldering
3-Terminal

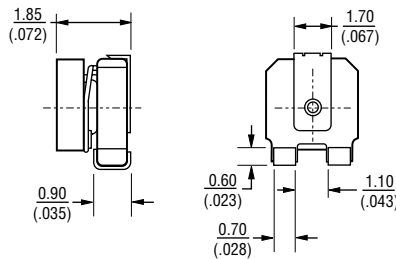
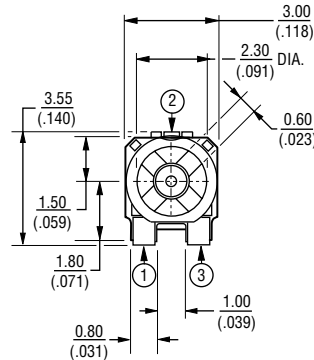

SUGGESTED PWB LAYOUT

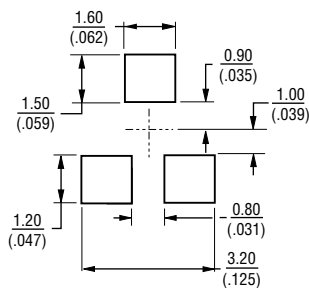

DIMENSIONS: MM/(INCHES)

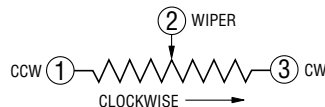

Standard Resistance Table

Resistance (Ohms)	Resistance Code	Part Marking
100	101	12
200	201	22
500	501	52
1,000	102	13
2,000	202	23
5,000	502	53
10,000	103	14
20,000	203	24
50,000	503	54
100,000	104	15
200,000	204	25
500,000	504	55
1,000,000	105	16

Popular distribution resistance values listed in **boldface**.
 Special resistances available.

How To Order

TC03 X - 2 - 103 E

Model _____
 Style _____
 Orientation of parts in tape:
 Style X = Terminals away from
 sprocket holes
 Standard or Modified _____
 Product Indicator _____
 -2 = Cross Slot Rotor
 (Standard Product)
 Resistance Code _____
 Embossed Tape Designator _____
 Consult factory for other available options.

Specifications are subject to change without notice.
 *RoHS Directive 2002/95/EC Jan 27 2003 including Annex.
 Customers should verify actual device performance in
 their specific applications. REV 09/04



BOURNS®

TC22 2 mm SMD Trimming Potentiometer

Features

- Recommended for reflow processing
- Rotor design compatible with pick and place and automatic adjustment equipment
- 2 mm size meets EIA/EIAJ standard trimmer footprint
- RoHS compliant† – See page 155 for processing information on lead free surface mount trimmers

Electrical Characteristics

Standard Resistance Range100 ohms to 1 megohm
 (see standard resistance table)
 Resistance Tolerance±25 % std.
 Absolute Minimum Resistance
 ≤1 K Ohms20 ohms max.
 >1 K Ohms2 % max. of TR
 Contact Resistance Variation5 % max.
 ResolutionInfinite
 Adjustment Angle260 ° ±20 °

Environmental Characteristics

Power Rating (50 VDC max.)
 70 °C0.1 watt
 Temperature Range-40 °C to +100 °C
 Temperature Coefficient±250 ppm/°C
 Humidity95 % RH
 TRS max.±5 %
 Load Life
@ 70 °C rated power 1000 hours
 TRS ±5 %
 Rotational Cycling20 cycles
 TRS ±5 %

Physical Characteristics

Torque0.49-7.84 mN-m max.
 Mechanical Angle270 ° ±20 °
 MarkingPart marking code
 Standard Packaging3000 pcs./7 " reel

Standard Resistance Table

Resistance		Resistance	
Ohms	Code	Ohms	Code
100	101	20,000	203
200	201	50,000	503
500	501	100,000	104
1,000	102	200,000	204
2,000	202	500,000	504
5,000	502	1,000,000	105
10,000	103		

Popular distribution resistance values listed in **boldface**.

How To Order

TC22 X - 2 - 103 E

Model _____
 Style _____
 Standard or Modified
 Product Indicator _____
 -2 = Cross Slot Rotor
 Resistance Code _____
 Embossed Tape Designator _____
 E = 3000 pcs./7 " Reel (Standard)

Product Dimensions

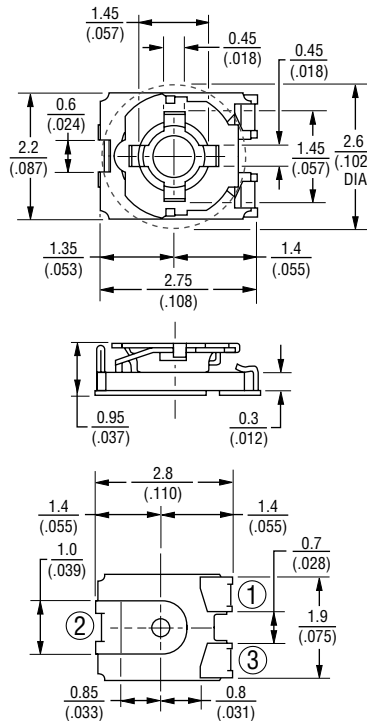

Recommended Land Pattern

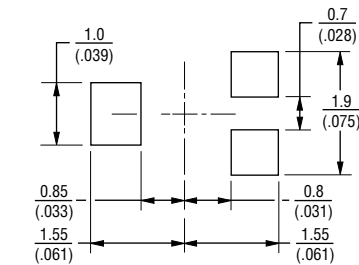

DIMENSIONS: MM/(INCHES)

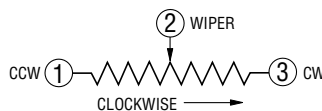

Packaging Specifications

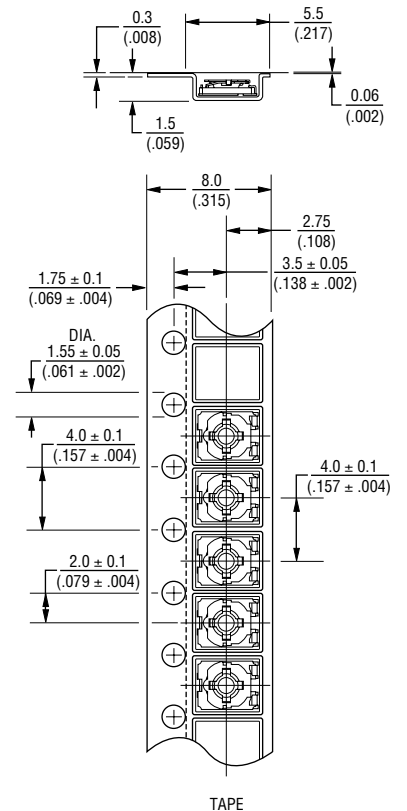

Specifications are subject to change without notice.
 †RoHS Directive 2002/95/EC Jan 27 2003 including Annex.
 Customers should verify actual device performance in their specific applications.
 REV 09/04

Trimmer Data Sheets

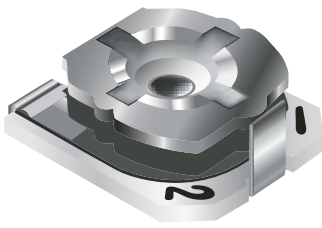

BOURNS®

TC33 3 mm SMD Trimming Potentiometer

Features

- Recommended for reflow processing
- Rotor design compatible with pick and place and automatic adjustment equipment
- 3 mm size meets EIA/EIAJ standard trimmer footprint
- RoHS compliant* – See page 155 for processing information on lead free surface mount trimmers

Electrical Characteristics

Standard Resistance Range100 ohms to 1 megohm
 (see standard resistance table)
 Resistance Tolerance±25 % std.
 Absolute Minimum Resistance
 ≤1 K Ohms20 ohms max.
 >1 K Ohms2 % max. of TR
 Contact Resistance Variation5 % max.
 ResolutionEssentially infinite
 Adjustment Angle260° ±20°

Environmental Characteristics

Power Rating (50 VDC max.)
 70 °C0.1 watt
 Temperature Range-40 °C to +120 °C
 Temperature Coefficient±250 ppm/°C
 Humidity95 %RH
 TRS max.±5 %
 Load Life
@ 70 °C rated power 1000 hours
 TRS ±5 %
 Rotational Cycling20 cycles
 TRS ±10 %

Physical Characteristics

Torque0.98-11.76 mN-m max.
 Mechanical Angle270° ±20°
 MarkingPart marking code
 Standard Packaging2500 pcs./7" reel
 Adjustment ToolH-90

Standard Resistance Table

Resistance		Resistance	
Ohms	Code	Ohms	Code
100	101	20,000	203
200	201	30,000	303
300	301	50,000	503
500	501	100,000	104
1,000	102	200,000	204
2,000	202	300,000	304
3,000	302	500,000	504
5,000	502	1,000,000	105
10,000	103		

Popular distribution resistance values listed in **boldface**.
 Special resistances available.

Specifications are subject to change without notice.
 *RoHS Directive 2002/95/EC Jan 27 2003 including Annex.
 Customers should verify actual device performance in their specific applications.
 REV 09/04

Product Dimensions

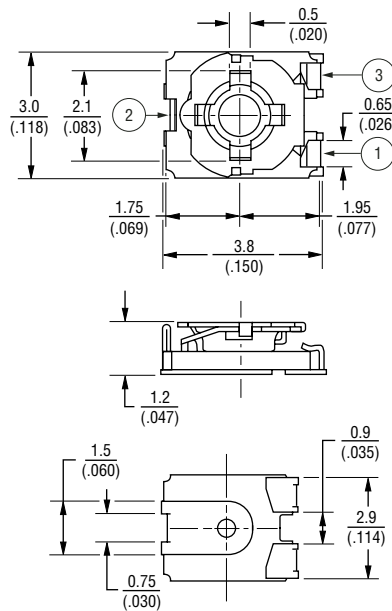

Recommended Land Pattern

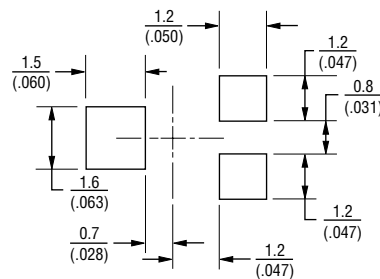

DIMENSIONS: MM/(INCHES)
 TOLERANCES: ±.3/(±.010) EXCEPT WHERE NOTED

How To Order

TC33 X - 2 - 103 E

Model _____
 Style _____
 Standard Product Indicator
 -2 = Cross Slot Rotor
 Resistance Code _____
 Embossed Tape Designator
 E = 2500 pcs./7" Reel (Standard)
 G = 9000 pcs./13" Reel

Packaging Specifications

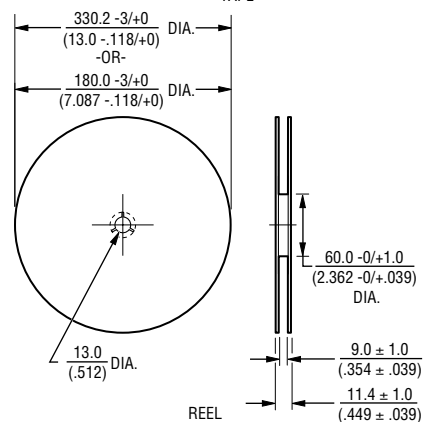
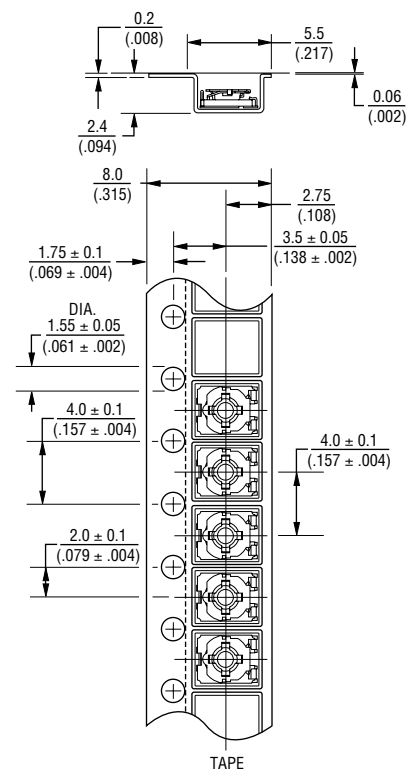

Meets EIA 481

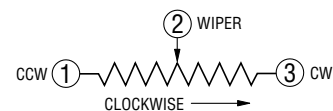

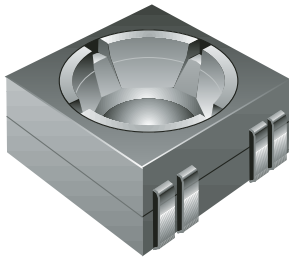

BOURNS®

TC73 Trimming Potentiometer

Features

- Recommended for reflow processing
- Rotor design compatible with pick and place and automatic adjustment equipment
- Supplied in 8 mm embossed tape, compatible with automatic assembly equipment
- Carbon element
- RoHS compliant* – See page 155 for processing information on lead free surface mount trimmers

Electrical Characteristics

Standard Resistance Range500 to 1 megohm
(see standard resistance table)
Resistance Tolerance±30 % std.
Absolute Minimum Resistance
≤1K Ohms20 ohms max.
>1K Ohms2 % max. of TR
Contact Resistance Variation
.....5 % max.
ResolutionInfinite
Adjustment Angle260 ° ±20 °(-2)

Environmental Characteristics

Power Rating (50 VDC max.)
50 °C0.05 watt
Temperature Range-25 °C to +85 °C
Temperature Coefficient ±250 ppm/°C
Humidity95 %RH
500 hours
TRS max.+15 % to -2 %
Load Life
.....@ 50 °C rated power 500 hours
TRS ±5 %
Rotational Cycling20 turns
TRS ±20 %

Physical Characteristics

Torque10-150 g-cm max.
Mechanical Angle
.....Continuous; 260 ° ± 20 °
MarkingPart marking code
Standard Packaging2000 pcs./7" reel

Soldering Process

Hand SolderingSoldering Iron of 20 W
or less controlled at 280 °C for about
3 sec. while applying solder
Reflow SolderingPeak temperature
or reflow oven should be
set to 240 °C max.

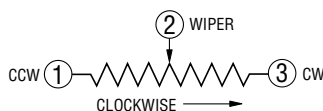

Specifications are subject to change without notice.
*RoHS Directive 2002/95/EC Jan 27 2003 including Annex.
Customers should verify actual device performance in
their specific applications. REV 09/04

Product Dimensions

TC73X/W-2

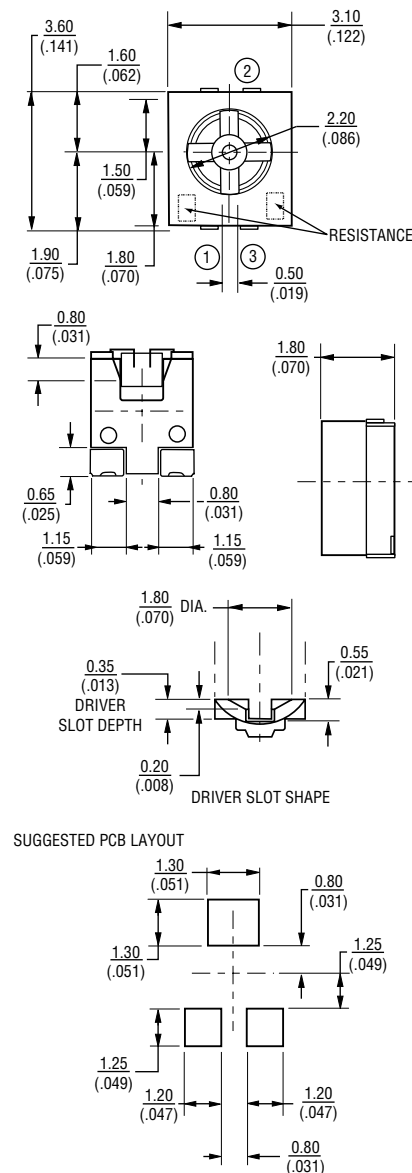

DIMENSIONS: MM/(INCHES)

Standard Resistance Table

Resistance (Ohms)	Part Marking	Part Marking
500	52	501
1,000	13	102
2,000	23	202
5,000	53	502
10,000	14	103
20,000	24	203
50,000	54	503
100,000	15	104
200,000	25	204
500,000	55	504
1,000,000	16	105

Popular distribution resistance values listed in **boldface**.
Special resistances available.

How To Order

Model TC73 X - 1 - 103 E
Style _____
Orientation of Parts in Tape:
Style X: Terminals Away From Sprocket Holes
Style W: Terminals in Direction to Sprocket Holes (Preferred)
Standard or Modified _____
Product Indicator _____
-1 = Mechanical Rotation Stop (Preferred)
-2 = Continuous
Resistance Code _____
Embossed Tape Designator _____
E = 2000 pcs. per Reel, 8 mm Tape
Consult factory for other available options.

AVAILABLE THROUGH DISTRIBUTION



BOURNS®

TC86 6 mm Round Trimming Potentiometer

Features

- 6 mm Round / Single-Turn / Cermet Industrial / Open Frame
- Cross slot adjustment options
- Horizontal and vertical mounting styles
- Dust resistant/splash resistant covers
- Front and top adjust styles
- RoHS compliant*

Electrical Characteristics

Standard Resistance Range100 ohms to 1 megohm
 (see standard resistance table)
 Resistance Tolerance±20 % std.
 (tighter tolerance available)
 Absolute Minimum Resistance
 ≤ 500 Ohms10 ohms max.
 > 500 Ohms2 % max. of TR
 Contact Resistance Variation5 % max.
 ResolutionInfinite
 Adjustment Angle240 ° ±20 °

Environmental Characteristics

Power Rating (100 VDC max.)
 70 °C0.3 watt
 Temperature Range-30 °C to +85 °C
 Temperature Coefficient±250 ppm/°C
 Humidity95 % RH
 TRS ±5 %
 Load Life500 hours @ 70 °C
 TRS ±5 %
 Rotational Cycling50 cycles
 TRS ±10 %

Physical Characteristics

Torque30-300 gf-cm
 Mechanical Angle240 ° ±20 °
 MarkingPart marking code
 Standard Packaging200 pcs./bag
 Adjustment ToolH-90
 Aqueous cleaning not recommended

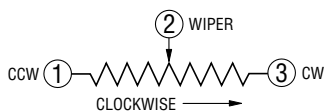

Product Dimensions

Top Adjust Common Dimensions

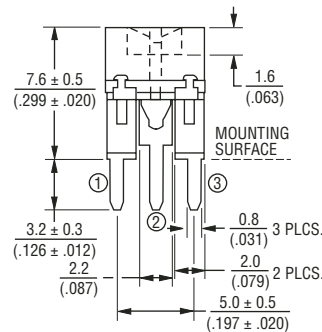
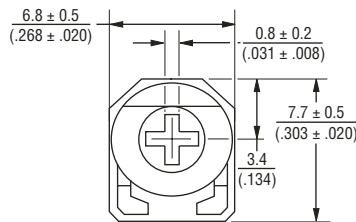

TC86P

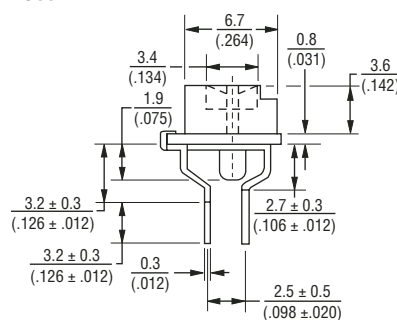

TC86F

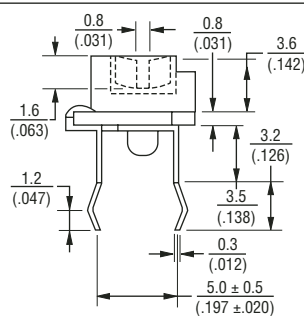

Side Adjust Common Dimensions

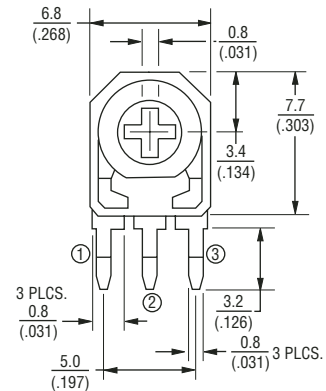

TC86W

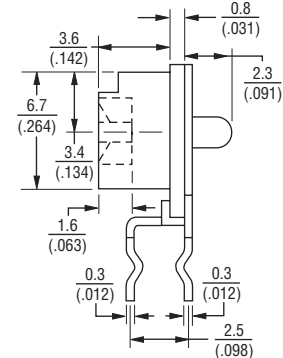

TC86K

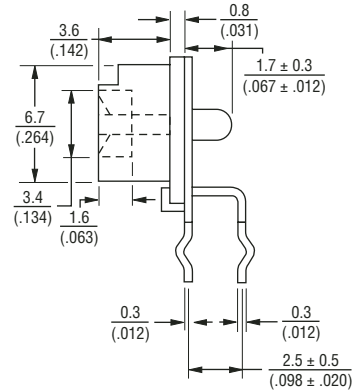

DIMENSIONS: MM/(INCHES)
 TOLERANCES: ±.25/(±.010) EXCEPT WHERE NOTED

Specifications are subject to change without notice.
 *RoHS Directive 2002/95/EC Jan 27 2003 Including Annex.
 Customers should verify actual device performance in their specific applications.
 REV 09/04

TC86 – Suggested PCB Layout and Ordering Information

Suggested PCB Layout – Style F

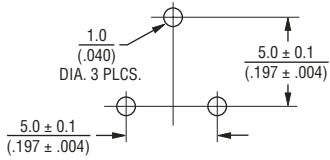

Suggested PCB Layout – Styles K, P, W

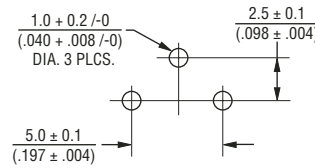

Standard Resistance Table

Resistance (Ohms)	Resistance Code
100	101
200	201
500	501
1,000	102
2,000	202
5,000	502
10,000	103
20,000	203
50,000	503
100,000	104
200,000	204
500,000	504
1,000,000	105

Popular distribution resistance values listed in **boldface**.

How To Order

Model _____
 Style _____
 Standard Product Indicator _____
 Resistance Code _____

TC86 W - 1 - 103

Specifications are subject to change without notice.
 Customers should verify actual device performance in their specific applications.

AVAILABLE THROUGH DISTRIBUTION



BOURNS®

TC89 9 mm Round Trimming Potentiometer

Features

- 9 mm Round / Single-Turn / Cermet Industrial / Open Frame
- Both sides adjust
- Horizontal and vertical mounting styles
- Dust resistant/splash resistant covers
- PC board stand-offs
- RoHS compliant†

Electrical Characteristics

Standard Resistance Range100 ohms to 1 megohm
 (see standard resistance table)
 Resistance Tolerance±20 % std.
 Absolute Minimum Resistance
 ≤500 Ohms10 ohms max.
 >500 Ohms2 % max. of TR
 Contact Resistance Variation5 % max.
 Resolution.....Infinite
 Adjustment Angle270 ° ±15 °

Environmental Characteristics

Power Rating (250 VDC max.)
 70 °C0.5 watt
 Temperature Range.....-30 °C to +100 °C
 Temperature Coefficient±250 ppm/°C
 Humidity95 % RH
 TRS ±5 %
 Load Life500 hours @ 70 °C
 TRS ±5 %
 Rotational Cycling.....50 cycles
 TRS ±10 %

Physical Characteristics

Torque50-350 gf-cm
 Mechanical Angle270 ° ±15 °
 Marking.....Part marking code
 Standard Packaging200 pcs./bag
 Adjustment ToolH-90
 Aqueous cleaning not recommended

Standard Resistance Table

Resistance (Ohms)	Resistance Code
100	101
200	201
500	501
1,000	102
2,000	202
5,000	502
10,000	103
20,000	203
50,000	503
100,000	104
200,000	204
500,000	504
1,000,000	105

Popular distribution resistance values listed in **boldface**.

Specifications are subject to change without notice.
 †RoHS Directive 2002/95/EC Jan 27 2003 including Annex.
 Customers should verify actual device performance in their specific applications.
 REV 09/04

Product Dimensions

Top Adjust TC89P

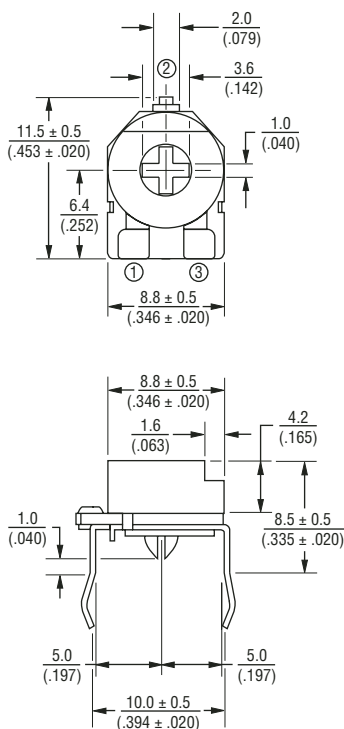

Side Adjust TC89W

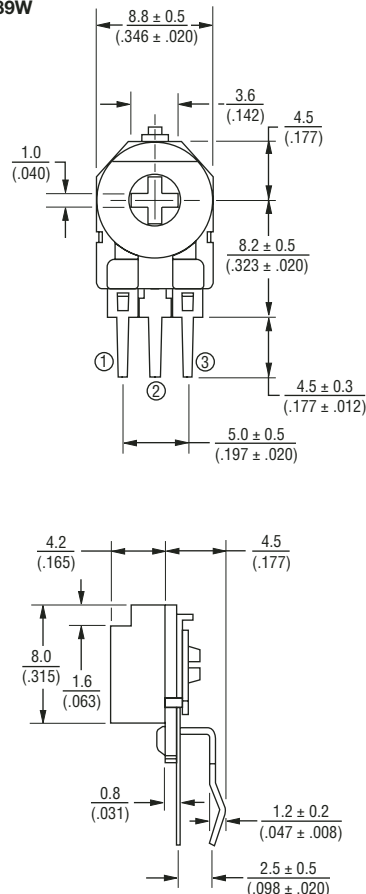

Suggested PCB Layout

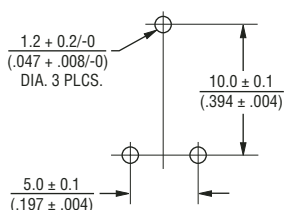

DIMENSIONS: MM/(INCHES)
 TOLERANCES: ±.25/(±.010) EXCEPT WHERE NOTED

Suggested PCB Layout

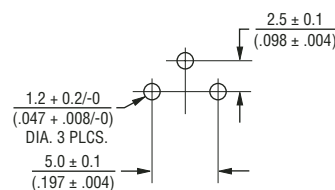

How To Order

TC89 P - 1 - 103

Model _____
 Style _____
 Standard Product Indicator _____
 Resistance Code _____

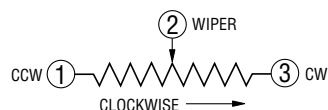

Trimmer Data Sheets

Military Products

Mil-Spec Numbering System – Defined

Non-Wirewound RJ Styles

MIL-PRF-22097 RJ24 F W 103

Style _____

Characteristic _____

Temperature Coefficient Max.	±100 ppm/°c
Contact Resistance Variation Max.	1 %
Thermal Shock	1 %
Humidity	1 %
Shock	1 %
Vibration	1 %
Load Life	2 %
Low Temperature	1 %
High Temperature	2 %
Rotational Life	2 %

Terminal Type _____

Resistance Code _____

First Two Digits Significant
Last Digit = Number of Zeroes
(103 = 10,000 ohms)

Non-Wirewound RJR Styles – High Reliability

MIL-PRF-39035 RJR24 F W 102 P

Style _____

Characteristic _____

Temperature Coefficient Max.	±100 ppm/°c
Contact Resistance Variation Max.	1 %
Thermal Shock	1 %
Humidity	1 %
Shock	1 %
Vibration	1 %
Load Life	
2,000 Hours	3 %
10,000 Hours	3 %
Low Temperature	1 %
High Temperature	3 %
Rotational Life	2 %
Conditioning	1-1/2 %

Terminal Type _____

Resistance Code _____

First Two Digits Significant
Last Digit = Number of Zeroes
(102 = 1,000 ohms)

Failure Rate _____

(% Failures/1,000 Hours – 60 % Confidence)

M = 1.0 %
P = 0.1 %
R = .01 %

Wirewound RT Styles

MIL-PRF-27208 RT24 C2 P 101

Style _____

Characteristic _____

C = Temperature Coefficient ±50 ppm/°C
2 = 85 ° Rating Temperature, 150 ° Maximum Operating Temperature

Terminal Type _____

Resistance Code _____

First Two Digits Significant
Last Digit = Number of Zeroes
(101 = 100 ohms)

High-Rel Wirewound Specification

MIL-PRF-39015 RTR Styles

This specification has a procedure for ordering, processing, and marking parts entirely different than the other three specifications. IT DOES NOT USE THE TYPE DESIGNATION NUMBER AS THE PART NUMBER.

The number to order by consists of:

- The individual specification sheet number
M39015/2 (for style RTR22)
M39015/3 (for style RTR24)
- A dash number from the specification sheet table for the resistance value

M39015/2		M39015/3	
-003	500	-006	500
-004	1K	-007	1K
-005	2K	-008	2K
-006	5K	-009	5K
-007	10K	-101	10K
-008	20K		

- Terminal Type
- Failure rate level M
M = 1 %
% Failure/1,000 Hours – 60% Confidence

Examples of Part Numbers

M39015/2 – 006LM
5K Term. Type L – Failure Rate M

M39015/3 – 010XM
10K Term. Type X – Failure Rate M

The table on the next page shows all part numbers covered by this specification, the conversion to the RTR type designation number required by the supplier to manufacture the part, and the number that will be marked on the units you receive (same as part number ordered but with the letter “J” in front of it). The letter “J” is a government mark and it is certification that the parts comply with the specification.

Information Notes:

- M39015/3 was added to the MIL-SPEC after its original release.

Specifications are subject to change without notice.
Customers should verify actual device performance in their specific applications.

Mil-Spec Numbering System – How to Order

Bourns High Reliability Mil-Spec Part Numbers

Order By	Process By*	Marked With	Terminal Types	Failure Rate
M39015/2-003(TS)(FR)	RTR22D(TS)501(FR)	JM39015/2-003(TS)(FR)	L, P, W, X	M
M39015/2-004(TS)(FR)	RTR22D(TS)102(FR)	JM39015/2-004(TS)(FR)		
M39015/2-005(TS)(FR)	RTR22D(TS)202(FR)	JM39015/2-005(TS)(FR)		
M39015/2-006(TS)(FR)	RTR22D(TS)502(FR)	JM39015/2-006(TS)(FR)		
M39015/2-007(TS)(FR)	RTR22D(TS)103(FR)	JM39015/2-007(TS)(FR)		
M39015/2-008(TS)(FR)	RTR22D(TS)203(FR)	JM39015/2-008(TS)(FR)		
M39015/3-006(TS)(FR)	RTR24D(TS)501(FR)	JM39015/3-006(TS)(FR)	P, W, X	M
M39015/3-007(TS)(FR)	RTR24D(TS)102(FR)	JM39015/3-007(TS)(FR)	P, W, X	M
M39015/3-008(TS)(FR)	RTR24D(TS)202(FR)	JM39015/3-008(TS)(FR)		
M39015/3-009(TS)(FR)	RTR24D(TS)502(FR)	JM39015/3-009(TS)(FR)		
M39015/3-010(TS)(FR)	RTR24D(TS)103(FR)	JM39015/3-010(TS)(FR)		

*May also order using this part number.

Qualified Part Numbers

RT/RTR22 (Commercial Model 3250)

Standard Values (ohms)	RT22C2_____				Nominal Resolution (percent)
	L	P	W	X	
10	—	—	—	—	—
20	—	—	—	—	—
50	RT22C2L500	RT22C2P500	RT22C2W500	RT22C2X500	0.80
100	RT22C2L101	RT22C2P101	RT22C2W101	RT22C2X101	0.90
200	RT22C2L201	RT22C2P201	RT22C2W201	RT22C2X201	0.70
500	RT22C2L501	RT22C2P501	RT22C2W501	RT22C2X501	0.60
1K	RT22C2L102	RT22C2P102	RT22C2W102	RT22C2X102	0.40
2K	RT22C2L202	RT22C2P202	RT22C2W202	RT22C2X202	0.30
5K	RT22C2L502	RT22C2P502	RT22C2W502	RT22C2X502	0.25
10K	RT22C2L103	RT22C2P103	RT22C2W103	RT22C2X103	0.19
20K	RT22C2L203	RT22C2P203	RT22C2W203	RT22C2X203	0.16

Standard Values (ohms)	RTR22D_____				Nominal Resolution (percent)
	L	P	W	X	
10	—	—	—	—	—
20	—	—	—	—	—
50	—	—	—	—	—
100	—	—	—	—	—
200	—	—	—	—	—
500	RTR22DL501M	RTR22DP501M	RTR22DW501M	RTR22DX501M	0.60
1K	RTR22DL102M	RTR22DP102M	RTR22DW102M	RTR22DX102M	0.40
2K	RTR22DL202M	RTR22DP202M	RTR22DW202M	RTR22DX202M	0.30
5K	RTR22DL502M	RTR22DP502M	RTR22DW502M	RTR22DX502M	0.25
10K	RTR22DL103M	RTR22DP103M	RTR22DW103M	RTR22DX103M	0.19
20K	RTR22DL203M	RTR22DP203M	RTR22DW203M	RTR22DX203M	0.16

Bourns reserves the right per MIL-PRF-39035 to substitute a higher grade temperature characteristic or failure rate (QPL) than requested.

Qualified Part Numbers

RT/RTR24 (Commercial Model 3290)

Standard Values (ohms)	RT24C2_____			RTR24D_____			Nominal Resolution (percent)
	P	W	X	P	W	X	
10	RT24C2P100	RT24C2W100	RT24C2X100	—	—	—	1.11
20	RT24C2P200	RT24C2W200	RT24C2X200	—	—	—	0.93
50	RT24C2P500	RT24C2W500	RT24C2X500	—	—	—	0.62
100	RT24C2P101	RT24C2W101	RT24C2X101	—	—	—	0.60
200	RT24C2P201	RT24C2W201	RT24C2X201	—	—	—	0.54
500	RT24C2P501	RT24C2W501	RT24C2X501	RTR24DP501*	RTR24DW501*	RTR24DX501*	0.42
1K	RT24C2P102	RT24C2W102	RT24C2X102	RTR24DP102*	RTR24DW102*	RTR24DX102*	0.33
2K	RT24C2P202	RT24C2W202	RT24C2X202	RTR24DP202*	RTR24DW202*	RTR24DX202*	0.26
5K	RT24C2P502	RT24C2W502	RT24C2X502	RTR24DP502*	RTR24DW502*	RTR24DX502*	0.20
10K	RT24C2P103	RT24C2W103	RT24C2X103	RTR24DP103*	RTR24DW103*	RTR24DX103*	0.17

*Last letter in number is failure rate level. M = 1.0 %; P = 0.1 %; R = 0.01 %

RT12 (Commercial Model 3057)

Standard Values (ohms)	RT12C2_____			Nominal Resolution (percent)
	L	P	Y	
10	RT12C2L100	RT12C2P100	RT12C2Y100	2.40
20	RT12C2L200	RT12C2P200	RT12C2Y200	1.90
50	RT12C2L500	RT12C2P500	RT12C2Y500	1.40
100	RT12C2L101	RT12C2P101	RT12C2Y101	1.00
200	RT12C2L201	RT12C2P201	RT12C2Y201	0.86
500	RT12C2L501	RT12C2P501	RT12C2Y501	0.89
1K	RT12C2L102	RT12C2P102	RT12C2Y102	0.72
2K	RT12C2L202	RT12C2P202	RT12C2Y202	0.58
5K	RT12C2L502	RT12C2P502	RT12C2Y502	0.43
10K	RT12C2L103	RT12C2P103	RT12C2Y103	0.34
20K	RT12C2L203	RT12C2P203	RT12C2Y203	0.31

RT26 (Commercial Model 3260)

Standard Values (ohms)	RT26C2_____		Nominal Resolution (percent)
	W	X	
10	RT26C2W100	RT26C2X100	1.90
20	RT26C2W200	RT26C2X200	1.50
50	RT26C2W500	RT26C2X500	1.25
100	RT26C2W101	RT26C2X101	1.00
200	RT26C2W201	RT26C2X201	0.94
500	RT26C2W501	RT26C2X501	0.58
1K	RT26C2W102	RT26C2X102	0.50
2K	RT26C2W202	RT26C2X202	0.45
5K	RT26C2W502	RT26C2X502	0.34

RJ22 (Commercial Model 3252)

Standard Values (ohms)	RJ22F_____			
	L	P	W	X
10	RJ22FL100	RJ22FP100	RJ22FW100	RJ22FX100
20	RJ22FL200	RJ22FP200	RJ22FW200	RJ22FX200
50	RJ22FL500	RJ22FP500	RJ22FW500	RJ22FX500
100	RJ22FL101	RJ22FP101	RJ22FW101	RJ22FX101
200	RJ22FL201	RJ22FP201	RJ22FW201	RJ22FX201
500	RJ22FL501	RJ22FP501	RJ22FW501	RJ22FX501
1K	RJ22FL102	RJ22FP102	RJ22FW102	RJ22FX102
2K	RJ22FL202	RJ22FP202	RJ22FW202	RJ22FX202
5K	RJ22FL502	RJ22FP502	RJ22FW502	RJ22FX502
10K	RJ22FL103	RJ22FP103	RJ22FW103	RJ22FX103
20K	RJ22FL203	RJ22FP203	RJ22FW203	RJ22FX203
25K	RJ22FL253	RJ22FP253	RJ22FW253	RJ22FX253
50K	RJ22FL503	RJ22FP503	RJ22FW503	RJ22FX503
100K	RJ22FL104	RJ22FP104	RJ22FW104	RJ22FX104
250K	RJ22FL254	RJ22FP254	RJ22FW254	RJ22FX254
500K	RJ22FL504	RJ22FP504	RJ22FW504	RJ22FX504
1 MEG	RJ22FL105	RJ22FP105	RJ22FW105	RJ22FX105

Bourns reserves the right per MIL-PRF-39035 to substitute a higher grade temperature characteristic or failure rate (QPL) than requested.

Qualified Part Numbers

RJ24 (Commercial Model 3296 for P, W, X; Model 3292 for L)

Standard Values (ohms)	RJ24F_____			
	L	P	W	X
10	RJ24FL100	RJ24FP100	RJ24FW100	RJ24FX100
20	RJ24FL200	RJ24FP200	RJ24FW200	RJ24FX200
50	RJ24FL500	RJ24FP500	RJ24FW500	RJ24FX500
100	RJ24FL101	RJ24FP101	RJ24FW101	RJ24FX101
200	RJ24FL201	RJ24FP201	RJ24FW201	RJ24FX201
500	RJ24FL501	RJ24FP501	RJ24FW501	RJ24FX501
1K	RJ24FL102	RJ24FP102	RJ24FW102	RJ24FX102
2K	RJ24FL202	RJ24FP202	RJ24FW202	RJ24FX202
5K	RJ24FL502	RJ24FP502	RJ24FW502	RJ24FX502
10K	RJ24FL103	RJ24FP103	RJ24FW103	RJ24FX103
20K	RJ24FL203	RJ24FP203	RJ24FW203	RJ24FX203
25K	RJ24FL253	RJ24FP253	RJ24FW253	RJ24FX253
50K	RJ24FL503	RJ24FP503	RJ24FW503	RJ24FX503
100K	RJ24FL104	RJ24FP104	RJ24FW104	RJ24FX104
250K	RJ24FL254	RJ24FP254	RJ24FW254	RJ24FX254
500K	RJ24FL504	RJ24FP504	RJ24FW504	RJ24FX504
1 MEG	RJ24FL105	RJ24FP105	RJ24FW105	RJ24FX105

RJR24 (Commercial Model 3296)

Standard Values (ohms)	RJR24F_____		
	P	W	X
10	RJR24FP100*	RJR24FW100*	RJR24FX100*
20	RJR24FP200*	RJR24FW200*	RJR24FX200*
50	RJR24FP500*	RJR24FW500*	RJR24FX500*
100	RJR24FP101*	RJR24FW101*	RJR24FX101*
200	RJR24FP201*	RJR24FW201*	RJR24FX201*
500	RJR24FP501*	RJR24FW501*	RJR24FX501*
1K	RJR24FP102*	RJR24FW102*	RJR24FX102*
2K	RJR24FP202*	RJR24FW202*	RJR24FX202*
5K	RJR24FP502*	RJR24FW502*	RJR24FX502*
10K	RJR24FP103*	RJR24FW103*	RJR24FX103*
20K	RJR24FP203*	RJR24FW203*	RJR24FX203*
25K	RJR24FP253*	RJR24FW253*	RJR24FX253*
50K	RJR24FP503*	RJR24FW503*	RJR24FX503*
100K	RJR24FP104*	RJR24FW104*	RJR24FX104*
250K	RJR24FP254*	RJR24FW254*	RJR24FX254*
500K	RJR24FP504*	RJR24FW504*	RJR24FX504*
1 MEG	RJR24FP105*	RJR24FW105*	RJR24FX105*

RJ/RJR26 (Commercial Model 3262; Commercial Model 3266 for A & B)

Standard Values (ohms)	RJ26F_____			RJR26F_____				
	P	W	X	P	W	X	A**	B**
10	RJ26FP100	RJ26FW100	RJ26FX100	RJR26FP100*	RJR26FW100*	RJR26FX100*	RJR26FA100*	RJR26FB100*
20	RJ26FP200	RJ26FW200	RJ26FX200	RJR26FP200*	RJR26FW200*	RJR26FX200*	RJR26FA200*	RJR26FB200*
50	RJ26FP500	RJ26FW500	RJ26FX500	RJR26FP500*	RJR26FW500*	RJR26FX500*	RJR26FA500*	RJR26FB500*
100	RJ26FP101	RJ26FW101	RJ26FX101	RJR26FP101*	RJR26FW101*	RJR26FX101*	RJR26FA101*	RJR26FB101*
200	RJ26FP201	RJ26FW201	RJ26FX201	RJR26FP201*	RJR26FW201*	RJR26FX201*	RJR26FA201*	RJR26FB201*
500	RJ26FP501	RJ26FW501	RJ26FX501	RJR26FP501*	RJR26FW501*	RJR26FX501*	RJR26FA501*	RJR26FB501*
1K	RJ26FP102	RJ26FW102	RJ26FX102	RJR26FP102*	RJR26FW102*	RJR26FX102*	RJR26FA102*	RJR26FB102*
2K	RJ26FP202	RJ26FW202	RJ26FX202	RJR26FP202*	RJR26FW202*	RJR26FX202*	RJR26FA202*	RJR26FB202*
5K	RJ26FP502	RJ26FW502	RJ26FX502	RJR26FP502*	RJR26FW502*	RJR26FX502*	RJR26FA502*	RJR26FB502*
10K	RJ26FP103	RJ26FW103	RJ26FX103	RJR26FP103*	RJR26FW103*	RJR26FX103*	RJR26FA103*	RJR26FB103*
20K	RJ26FP203	RJ26FW203	RJ26FX203	RJR26FP203*	RJR26FW203*	RJR26FX203*	RJR26FA203*	RJR26FB203*
25K	RJ26FP253	RJ26FW253	RJ26FX253	RJR26FP253*	RJR26FW253*	RJR26FX253*	RJR26FA253*	RJR26FB253*
50K	RJ26FP503	RJ26FW503	RJ26FX503	RJR26FP503*	RJR26FW503*	RJR26FX503*	RJR26FA503*	RJR26FB503*
100K	RJ26FP104	RJ26FW104	RJ26FX104	RJR26FP104*	RJR26FW104*	RJR26FX104*	RJR26FA104*	RJR26FB104*
200K	—	—	—	RJR26FP204*	RJR26FW204*	RJR26FX204*	RJR26FA204*	RJR26FB204*
250K	RJ26FP254	RJ26FW254	RJ26FX254	RJR26FP254*	RJR26FW254*	RJR26FX254*	RJR26FA254*	RJR26FB254*
500K	RJ26FP504	RJ26FW504	RJ26FX504	RJR26FP504*	RJR26FW504*	RJR26FX504*	RJR26FA504*	RJR26FB504*
1 MEG	RJ26FP105	RJ26FW105	RJ26FX105	RJR26FP105*	RJR26FW105*	RJR26FX105*	RJR26FA105*	RJR26FB105*

*Last letter in number is failure rate level. M = 1.0 %; P = 0.1 %; R = 0.01 %

**Model RJR26FA commercial model is 3266W. Model RJR26FB commercial model is 3266X.

Bourns reserves the right per MIL-PRF-39035 to substitute a higher grade temperature characteristic or failure rate (QPL) than requested.

Qualified Part Numbers

RJ12 (Commercial Model 3059)

Standard Values (ohms)	RJ12F_____	
	P	Y
10	RJ12FP100	RJ12FY100
20	RJ12FP200	RJ12FY200
50	RJ12FP500	RJ12FY500
100	RJ12FP101	RJ12FY101
200	RJ12FP201	RJ12FY201
500	RJ12FP501	RJ12FY501
1K	RJ12FP102	RJ12FY102
2K	RJ12FP202	RJ12FY202
5K	RJ12FP502	RJ12FY502
10K	RJ12FP103	RJ12FY103
20K	RJ12FP203	RJ12FY203
25K	RJ12FP253	RJ12FY253
50K	RJ12FP503	RJ12FY503
100K	RJ12FP104	RJ12FY104
200K	RJ12FP204	RJ12FY204
250K	RJ12FP254	RJ12FY254
500K	RJ12FP504	RJ12FY504
1 MEG	RJ12FP105	RJ12FY105

RJ/RJR50 (Commercial Model 3329)

Standard Values (ohms)	RJ50F_____	RJR50F_____
	P	P
10	RJ50FP100	RJR50FP100*
20	RJ50FP200	RJR50FP200*
50	RJ50FP500	RJR50FP500*
100	RJ50FP101	RJR50FP101*
200	RJ50FP201	RJR50FP201*
500	RJ50FP501	RJR50FP501*
1K	RJ50FP102	RJR50FP102*
2K	RJ50FP202	RJR50FP202*
5K	RJ50FP502	RJR50FP502*
10K	RJ50FP103	RJR50FP103*
20K	RJ50FP203	RJR50FP203*
25K	RJ50FP253	RJR50FP253*
50K	RJ50FP503	RJR50FP503*
100K	RJ50FP104	RJR50FP104*
200K	—	RJR50FP204*
250K	RJ50FP254	RJR50FP254*
500K	RJ50FP504	RJR50FP504*
1 MEG	RJ50FP105	RJR50FP105*

*Last letter in number is failure rate level. M = 1.0 %; P = 0.1 %

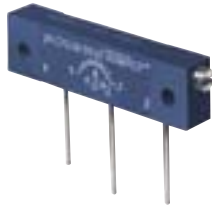

BOURNS®

RT12 Trimpot® Trimming Potentiometer

Features

- 1-1/4" Rectangular / Multiturn Wirewound / Industrial / Sealed
- Panel mount option available
- Listed on the QPL per MIL-PRF-27208
- RoHS compliant*

Electrical Characteristics

Standard Resistance Range 10 to 20K ohms
 (see standard resistance table)
 Resistance Tolerance ±5 % std.
 (tighter tolerance available)
 Absolute Minimum Resistance 0.1 % or 1 ohm max.
 (whichever is greater)
 Noise 100 ohms ENR max.
 Resolution See Resistance Table
 Insulation Resistance 500 vdc.
 1,000 megohms min.
 Dielectric Strength
 Sea Level 1,500 vac
 70,000 Feet 400 vac
 Adjustment Travel 22 turns nom.

Environmental Characteristics

Power Rating @ 70 °C 1 watt
 Power Rating @ 150 °C 0 watt
 Temperature Range -55 °C to +150 °C
 Temperature Coefficient ±50 ppm/°C
 Seal Test 85 °C Fluorinert*
 (pin styles only)
 Humidity MIL-STD-202 Method 106
 96 hours
 (2 % ΔTR, 100 Megohms IR)
 Vibration 30 G (1 % ΔTR; 0.5 %
 + resolution ΔVR)
 Shock 100 G (1 % ΔTR; 0.5 %
 + resolution ΔVR)
 Load Life 1,000 hours 1 watt @ 70 °C
 (2 % ΔTR)
 Rotational Life 200 cycles (2 % ΔTR)

Physical Characteristics

Torque 5.0 oz-in. max.
 Mechanical Stops Wiper idles
 Terminals Solderable pins and lugs
 Flexible leads (7 strands of 30 AWG)
 Weight 0.10 oz.
 Marking Manufacturer's trademark,
 resistance code, terminal numbers,
 date code, manufacturer's model
 number and style
 Wiper 50 % (Actual TR) ±10 %
 Flammability U.L. 94V-0
 Standard Packaging
 P&Y Style 10 pcs. per tube
 L Style 25 pcs. per bag
 Adjustment Tool H-90

*"Fluorinert" is a registered trademark of 3M Co.
 *RoHS Directive 2002/95/EC Jan 27 2003 including Annex.
 Specifications are subject to change without notice.
 Customers should verify actual device performance in
 their specific applications. REV 09/04

Product Dimensions

RT12C2L

Common Dimensions

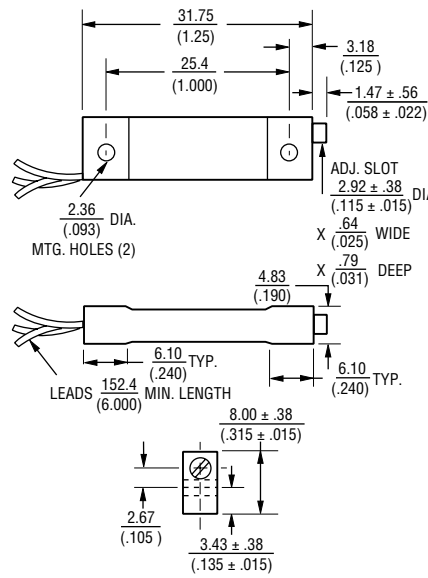

RT12C2P

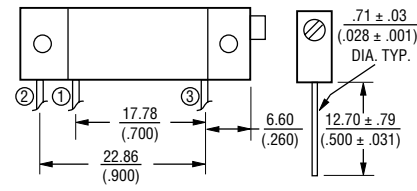

RT12C2Y

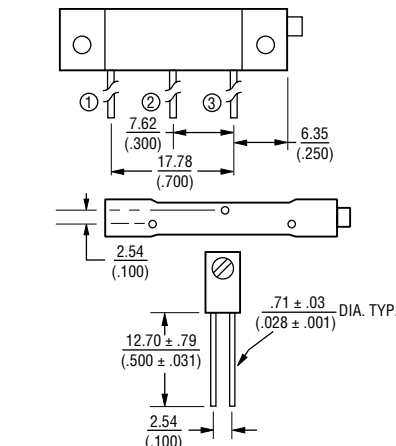

DIMENSIONS: MM/(INCHES)
 TOLERANCES: ±.25/(±.010) EXCEPT WHERE NOTED

Standard Resistance Table

Resistance (Ohms)	Resistance Code	Nominal Resolution (Percent)
10	100	2.40
20	200	1.90
50	500	1.40
100	101	1.00
200	201	0.86
500	501	0.89
1,000	102	0.72
2,000	202	0.58
5,000	502	0.43
10,000	103	0.34
20,000	203	0.31

How To Order

MIL-PRF-27208 **RT12 C2 P 101**
 Model _____
 Characteristic _____
 C = ±50 ppm/°C Temp Coeff. Max.
 2 = 85 °C Rating Temp.
 150 °C Max. Operating Temp.
 Terminal Style _____
 Resistance Code _____

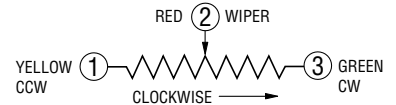

Military Trimmers

AVAILABLE THROUGH DISTRIBUTION

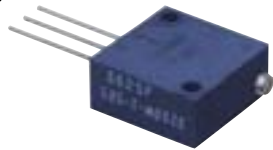

BOURNS®

RT22/RTR22 1/2" Square Trimming Potentiometer

Features

- Multiturn / Wirewound / Sealed
- Listed on the QPL per MIL-R-27208 and High-Rel MIL-R-39015
- Panel Mount option available

■ RoHS compliant†

Electrical Characteristics

Standard Resistance Range

- RT2250 to 20K ohms
- RTR22500 to 20K ohms
(see standard resistance table)
- Resistance Tolerance±5 % std.
(tighter tolerance available)
- Absolute Minimum Resistance
.....0.1 % or 1 ohm max.
(whichever is greater)
- Noise100 ohms ENR max.
- ResolutionSee Resistance Table
- Insulation Resistance500 vdc.
1,000 megohms min.

Dielectric Strength

- Sea Level1,000 vac
- 80,000 Feet400 vac
- Adjustment Travel25 turns nom.

Environmental Characteristics

- Power Rating @ 85 °C0.75 watt
- Power Rating @ 150 °C0 watt
- Temperature Range-65 °C to +150 °C
- Temperature Coefficient±50 ppm/°C
- Seal Test85 °C Fluorinert*
(pin styles only)
- HumidityMIL-STD-202 Method 106
- RT22(1 % ΔTR; 10 Megohms IR)
- RTR22(1 % ΔTR; 100 Megohms IR)
- Vibration30 G
(1 % ΔTR; 0.5 % + resolution ΔVR)
- Shock100 G
(1 % ΔTR; 0.5 % + resolution ΔVR)
- Load Life
- RT221,000 hours 0.75 watt @ 85 °C
(2 % ΔTR; 2 % + resolution ΔVR)
- RTR2210,000 hours 0.75 watt @ 85 °C
(3 % ΔTR; 2 % + resolution ΔTR)
- Rotational Life200 cycles (2 % ΔTR)

Physical Characteristics

- Torque5.0 oz-in. max.
- Mechanical StopsWiper idles
- Terminals
.....Flexible leads (7 strands of 30 AWG)
MIL-STD-202; Method 208
- Weight0.06 oz.
- Machine Screw Mounting
- Torque12 oz-in. max.
- MarkingMil-spec part number
- Wiper50 % (Actual TR) ±10 %
- FlammabilityU.L. 94V-0
- Standard Packaging
- P, W & X Styles25 pcs. per tube
- L Style25 pcs. per bag
- Adjustment ToolH-90

*"Fluorinert" is a registered trademark of 3M Co.
†RoHS Directive 2002/95/EC Jan 27 2003 including Annex. Specifications are subject to change without notice. Customers should verify actual device performance in their specific applications.
REV 09/04

Product Dimensions

RT22C2P/RTR22DP

Common Dimensions
(Pin Styles)

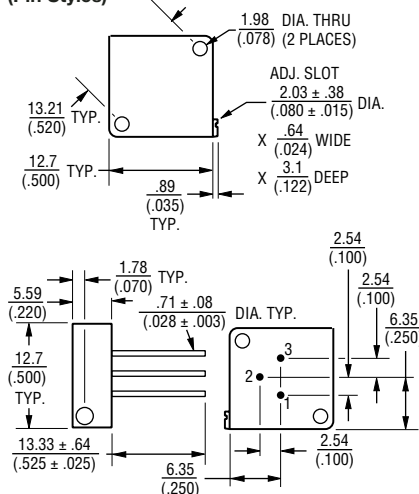

RT22C2W/RTR22DW

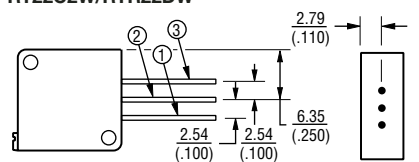

RT22C2X/RTR22DX

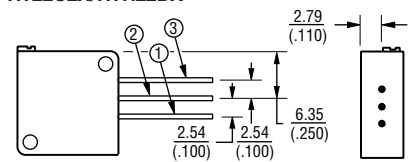

RT22C2L/RTR22DL

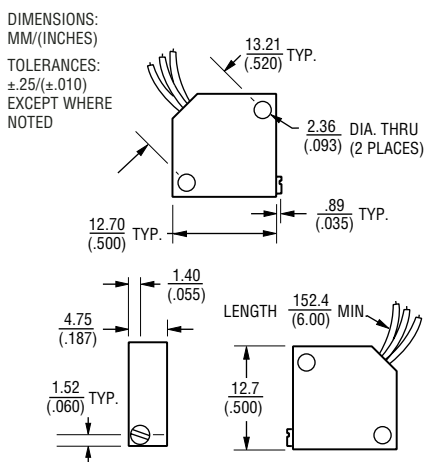

RT22 – Standard Resistance Table

Resistance (Ohms)	Resistance Code	Nominal Resolution (Percent)
50	500	0.80
100	101	0.90
200	201	0.70
500	501	0.60
1,000	102	0.40
2,000	202	0.30
5,000	502	0.25
10,000	103	0.19
20,000	203	0.16

RT22 – How To Order

MIL-PRF-27208 RT22 C2 P 501
Model _____
Characteristic _____
C = ±50 ppm/°C Temp. Coeff. Max.
2 = 85 °C Rating Temp.
150 °C Max. Operating Temp.
Terminal Style _____
Resistance Code _____

RTR22 – Standard Resistance Table

Resistance (Ohms)	Resistance Code	Nominal Resolution (Percent)
500	501	0.60
1,000	102	0.40
2,000	202	0.30
5,000	502	0.25
10,000	103	0.19
20,000	203	0.16

RTR22 – How To Order

MIL-PRF-39015 RTR22 D P 501 M
Model _____
Characteristic _____
D = ±50 ppm/°C Temp. Coeff. Max.
Terminal Style _____
Resistance Code _____
Failure Rate _____
M = 1.0 %

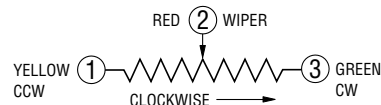

AVAILABLE THROUGH DISTRIBUTION



BOURNS®

RT24/RTR24 3/8" Square Trimming Potentiometer

Features

- Multiturn/ Wirewound / Industrial / Sealed
- Listed on the QPL per MIL-R-27208 and High-Rel MIL-R-39015
- Panel mount option available
- RoHS compliant*

Electrical Characteristics

Standard Resistance Range
 RT24 10 to 10K ohms
 RTR24 500 to 10K ohms
 (see standard resistance table)
 Resistance Tolerance ±5 % std.
 (tighter tolerance available)
 Absolute Minimum Resistance
 0.1 % or 1 ohm max.
 (whichever is greater)
 Noise 100 ohms ENR max.
 Resolution
 (see standard resistance table)
 Insulation Resistance 500 vdc.
 1,000 megohms min.
 Dielectric Strength
 Sea Level 1,000 vac
 80,000 Feet 350 vac
 Adjustment Travel 25 turns nom.

Environmental Characteristics

Power Rating @ 85 °C 0.75 watt
 Power Rating @ 150 °C 0 watt
 Temperature Range -65 °C to +150 °C
 Temperature Coefficient ±50 ppm/°C
 Seal Test 85 °C Fluorinert*
 Humidity
 RT24 (1 % ΔTR; 10 Megohms IR)
 RTR24 (1 % ΔTR; 100 Megohms IR)
 Vibration 20G
 (1 % ΔTR; 0.5 % + resolution ΔVR)
 Shock 100G
 (1 % ΔTR; 0.5 % + resolution ΔVR)
 Load Life
 RT24 1,000 hours 0.75 watt @ 85 °C
 (2 % ΔTR; 2 % + resolution ΔVR)
 RTR24 10,000 hours 0.75 watt @ 85 °C
 (3 % + resolution ΔVR)
 Rotational Life 200 cycles
 (2 % ΔTR)

Physical Characteristics

Torque 5.0 oz-in. max.
 Mechanical Stops Wiper idles
 Terminals MIL-STD-202; Method 208
 Weight 0.025 oz.
 Marking Mil-spec part number
 Wiper 50 % (Actual TR) ±10 %
 Flammability U.L. 94V-0
 Standard Packaging 50 pcs. per tube
 Adjustment Tool H-90

Product Dimensions

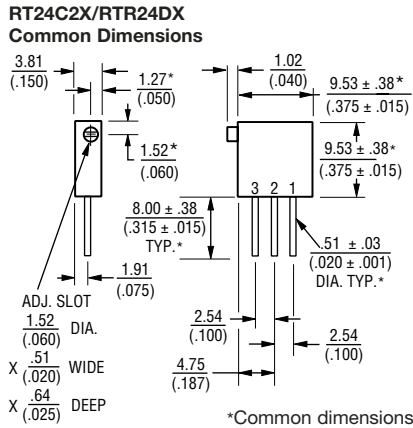

RT24C2P/RTR24DP

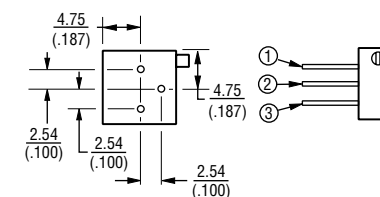

RT24C2W/RTR24DW

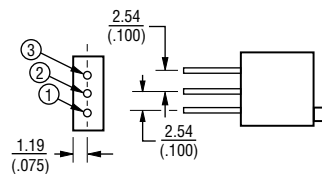

DIMENSIONS: MM/(INCHES)
 TOLERANCES: ±.25(±.010) EXCEPT WHERE NOTED

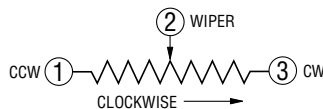

RT24 – Standard Resistance Table

Resistance (Ohms)	Resistance Code	Nominal Resolution (Percent)
10	100	1.11
20	200	0.93
50	500	0.62
100	101	0.60
200	201	0.54
500	501	0.42
1,000	102	0.33
2,000	202	0.26
5,000	502	0.20
10,000	103	0.17

RT24 – How To Order

MIL-PRF-27208 RT24 C2 P 501
 Model _____
 Characteristic _____
 C = ±50 ppm/°C Temp. Coeff. Max.
 2 = 85 °C Rating Temp.
 150 °C Max. Operating Temp.
 Terminal Style _____
 Resistance Code _____

RTR24 – Standard Resistance Table

Resistance (Ohms)	Resistance Code	Nominal Resolution (Percent)
500	501	0.42
1,000	102	0.33
2,000	202	0.26
5,000	502	0.20
10,000	103	0.17

RTR24 – How To Order

MIL-PRF-39015 RTR24 D P 202 M
 Model _____
 Characteristic _____
 D = ±50 ppm/°C Temp. Coeff. Max.
 Terminal Style _____
 Resistance Code _____
 Failure Rate _____
 M = 1.0 %

*"Fluorinert" is a registered trademark of 3M Co.
 *RoHS Directive 2002/95/EC Jan 27 2003 including Annex.
 Specifications are subject to change without notice.
 Customers should verify actual device performance in their specific applications. REV 09/04

Military Trimmers

AVAILABLE THROUGH DISTRIBUTION



BOURNS®

RT26 1/4 " Square Trimming Potentiometer

Features

- Multiturn / Wirewound / Industrial / Sealed
- Listed on the QPL per MIL-R-27208
- RoHS compliant†

Electrical Characteristics

Standard Resistance Range10 to 5K ohms
(see standard resistance table)
Resistance Tolerance±5 % std.
(tighter tolerance available)
Absolute Minimum Resistance0.25 % or 1 ohm max.
(whichever is greater)
Noise.....100 ohms ENR max.
Resolution.....See resistance table
Insulation Resistance500 vdc.
1,000 megohms min.
Dielectric Strength
Sea Level600 vac
80,000 Feet.....250 vac
Adjustment Angle11 turns nom.

Environmental Characteristics

Power Rating
85 °C0.25 watt
150 °C0 watt
Temperature Range.....-55 °C to +150 °C
Temperature Coefficient±50 ppm/°C
Seal Test.....85 °C Fluorinert*
Humidity.....MIL-STD-202 Method 106
(1 % ΔTR, 10 Megohms IR)
Vibration20 G
(1 % ΔTR; 1 % + resolution ΔVR)
Shock100 G
(1 % ΔTR; 1 % + resolution ΔVR)
Load Life....1,000 hours 0.25 watt @ 85 °C
(2 % ΔTR; 2 % + resolution ΔVR)
Rotational Life.....200 cycles
(2 % ΔTR)

Physical Characteristics

Torque3.0 oz-in. max.
Mechanical StopsWiper idles
Terminals.....MIL-STD-202; Method 208
Weight0.015 oz.
MarkingMil-spec part number
Wiper.....50 % (Actual TR) ±10 %
FlammabilityUL 94V-0
Standard Packaging50 pcs. per tube
Adjustment ToolH-90

Product Dimensions

RT26C2X

Common Dimensions

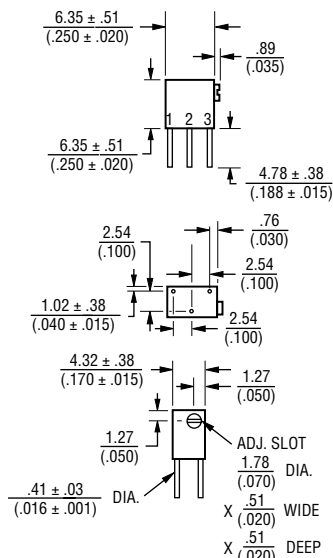

RT26C2W

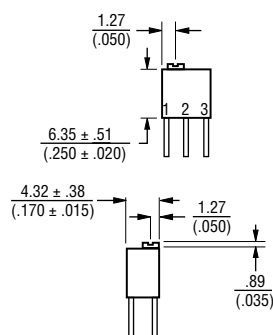

DIMENSIONS: MM/(INCHES)
TOLERANCES: ±.25/(±.010) EXCEPT WHERE NOTED

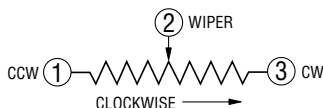

Standard Resistance Table

Resistance (Ohms)	Resistance Code	Nominal Resolution (Percent)
10	100	1.90
20	200	1.50
50	500	1.23
100	101	1.00
200	201	0.94
500	501	0.58
1,000	102	0.50
2,000	202	0.45
5,000	502	0.34

How To Order

MIL-PRF-27208 **RT26 C2 X 101**

Model _____

Characteristic _____

C = ±50 ppm/°C Temp. Coeff. Max.
2 = 85 °C Rating Temp.
150 °C Max. Operating Temp.

Terminal Style _____

Resistance Code _____

*"Fluorinert" is a registered trademark of 3M Co.
†RoHS Directive 2002/95/EC Jan 27 2003 Including Annex.
Specifications are subject to change without notice.
Customers should verify actual device performance in their specific applications.
REV 09/04

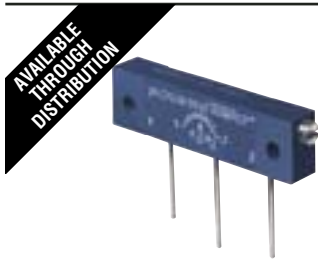

BOURNS®

RJ12 Trimpot® Trimming Potentiometer

Features

- 1-1/4 " Rectangular / Multiturn Cermet / Industrial / Sealed
- Panel mount option available
- Listed on the QPL per MIL-PRF-22097
- RoHS compliant*

Electrical Characteristics

Standard Resistance Range10 to 1 megohm
(see standard resistance table)
Resistance Tolerance±10 % std.
(tighter tolerance available)
Absolute Minimum Resistance1 % or 2 ohms max.
(whichever is greater)
Contact Resistance Variation1.0 % or 1 ohm max.
(whichever is greater)
Adjustability
Voltage±0.01 %
Resistance±0.05 %
ResolutionInfinite
Insulation Resistance500 vdc.
1,000 megohms min.
Dielectric Strength
Sea Level900 vac
70,000 Feet350 vac
Effective Travel22 turns nom.

Environmental Characteristics

Power Rating @ 70 °C (400 volts max.)1.0 watt
Power Rating @ 150 °C0 watt
Temperature Range-55 °C to +150 °C
Temperature Coefficient±100 ppm/°C
Seal Test85 °C Fluorinert*
(pin styles only)
HumidityMIL-STD-202 Method 106
(2 % ΔTR, 10 Megohms IR)
Vibration20 G (1 % ΔTR; 1 % ΔVR)
Shock50 G (1 % ΔTR; 1 % ΔVR)
Load Life1,000 hours 1.0 watt @ 70 °C
(3 % ΔTR; 1 % or 1 ohms, whichever is greater, CRV)
Rotational Life200 cycles
(2 % ΔTR; 1 % or 1 ohm, whichever is greater, CRV)

Physical Characteristics

Torque5.0 oz-in. max.
Mechanical StopsWiper idles
TerminalsSolderable printed circuit pins
Flexible leads(7 strands of 30 AWG)
Weight0.1 oz.
MarkingManufacturer's trademark, resistance code, terminal numbers, date code, manufacturer's model number and style
Wiper50 % (Actual TR) ±10 %
FlammabilityU.L. 94V-0
Standard Packaging10 pcs. per tube
Adjustment ToolH-90

Product Dimensions

RJ12FP

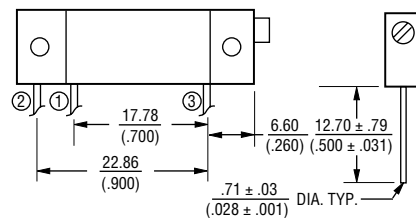

RJ12FY

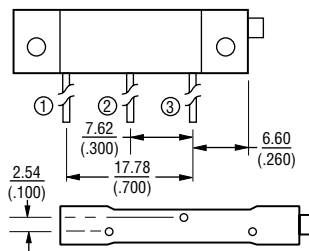

DIMENSIONS: MM/(INCHES)
TOLERANCES: ±.25(±.010) EXCEPT WHERE NOTED

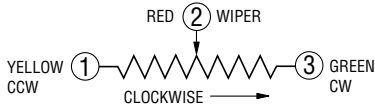

Standard Resistance Table

Resistance (Ohms)	Resistance Code
10	100
20	200
50	500
100	101
200	201
500	501
1,000	102
2,000	202
5,000	502
10,000	103
20,000	203
25,000	253
50,000	503
100,000	104
200,000	204
250,000	254
500,000	504
1,000,000	105

How To Order

MIL-PRF-22097 **RJ12 F Y 103**
Model _____
Characteristic _____
F = ±100 ppm/°C Temp. Coeff. Max.
Terminal Style _____
Resistance Code _____

*"Fluorinert" is a registered trademark of 3M Co.
*RoHS Directive 2002/95/EC Jan 27 2003 including Annex.
Specifications are subject to change without notice.
Customers should verify actual device performance in their specific applications. REV 09/04

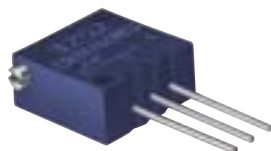

RJ22 1/2" Square Trimming Potentiometer

Features

- Multiturn / Cermet / Sealed
- Listed on the QPL per MIL-R-22097
- Panel mount option available

BOURNS®

Electrical Characteristics

Standard Resistance Range
.....10 ohms to 1 megohm
(see standard resistance table)

Resistance Tolerance.....±10 % std.
(tighter tolerance available)

Absolute Minimum Resistance
.....1 ohm max.

Contact Resistance Variation
.....2 % or 2 ohms max.
(whichever is greater)

Adjustability

Voltage.....±0.01 %

Resistance.....±0.05 %

Resolution.....Infinite

Insulation Resistance.....500 vdc.
1,000 megohms min.

Dielectric Strength

Sea Level.....1,000 vac

80,000 Feet.....400 vac

Effective Travel.....25 turns nom.

Environmental Characteristics

Power Rating @ 85 °C (400 volts max.)
.....0.50 watt

Power Rating @ 150 °C.....0 watt

Temperature Range.....-65 °C to +150 °C

Temperature Coefficient.....±100 ppm/°C

Seal Test.....85 °C Fluorinert*
(pin styles only)

Humidity
.....MIL-STD-202 Method 106
(1 % ΔTR; 10 Megohms IR)

Vibration.....20 G (1 % ΔTR; 1 % ΔVR)

Shock.....100 G (1 % ΔTR; 1 % ΔVR)

Load Life.....1,000 hours 0.5 watt @ 85 °C
(2 % ΔTR; 1 % ΔVR)

Rotational Life.....200 cycles
2 % ΔTR

Physical Characteristics

Torque.....5.0 oz-in. max.

Mechanical Stops.....Wiper idles

Terminals.....MIL-STD-202; Method 208

Flexible leads.....(7 strands of 30 AWG)

Weight.....0.065 oz.

Wiper.....50 % (Actual TR) ±10 %

Flammability.....U.L. 94V-0

Machine Screw Mounting

Torque.....12 oz-in. max.

Marking.....Mil-spec part number

Standard Packaging

X, P & W Styles.....25 pcs. per tube

L Style.....25 pcs. per bag

Adjustment Tool.....H-90

Product Dimensions

RJ22FP Common Dimensions (Pin Styles)

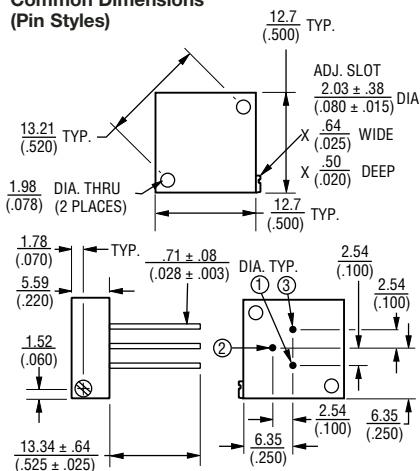

RJ22FW

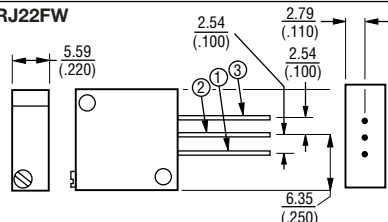

RJ22FL

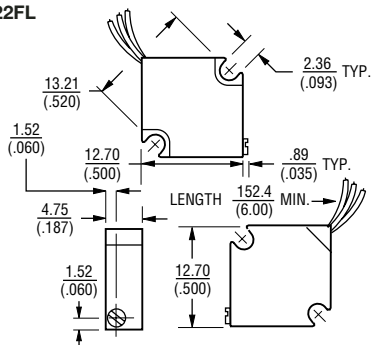

RJ22FX

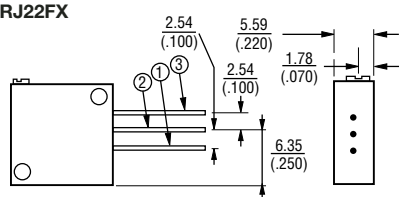

DIMENSIONS: MM/(INCHES)
TOLERANCES: ±.25/(±.010) EXCEPT WHERE NOTED

Standard Resistance Table

Resistance (Ohms)	Resistance Code
10	100
20	200
50	500
100	101
200	201
500	501
1,000	102
2,000	202
5,000	502
10,000	103
20,000	203
25,000	253
50,000	503
100,000	104
250,000	254
500,000	504
1,000,000	105

How To Order

MIL-PRF-22097 RJ22 F W 103

Model _____

Characteristic _____
F = ±100 ppm/°C Temp. Coeff. Max.

Terminal Style _____

Resistance Code _____

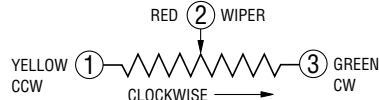

**"Fluorinert" is a registered trademark of 3M Co.
Specifications are subject to change without notice.
Customers should verify actual device performance in
their specific applications. REV 09/04

AVAILABLE THROUGH DISTRIBUTION

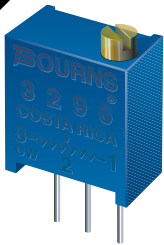

BOURNS®

RJ24/RJR24 3/8" Square Trimming Potentiometer

Features

- Multiturn / Cermet / Industrial / Sealed
- Standoffs
- Patent #4427966 drive mechanism
- Listed on the QPL per MIL-R-22097 and High-Rel Mil-R-39035

Electrical Characteristics

Standard Resistance Range
.....10 to 1 megohm
(see standard resistance table)

Resistance Tolerance.....±10 % std.

Absolute Minimum Resistance
.....1 ohm max.

Contact Resistance Variation
.....3.0 % or 3 ohms max.
(whichever is greater)

Adjustability
Voltage.....±0.01 %
Resistance.....±0.05 %

Resolution.....Infinite

Insulation Resistance.....500 vdc
1,000 megohms min.

Dielectric Strength
Sea Level.....1,000 vac
80,000 Feet.....400 vac
Effective Travel.....25 turns nom.

Environmental Characteristics

Power Rating (300 volts max.)
85 °C.....0.5 watt
150 °C.....0 watt

Temperature Range.....-55 °C to +150 °C

Temperature Coefficient..... ±100 ppm/°C

Seal Test.....85 °C Fluorinert*

Humidity.....MIL-STD-202 Method 106

RJ24.....96 hours
(1 % ΔTR, 10 Megohms IR)

RJR24.....96 hours
(1 % ΔTR, 100 Megohms IR)

Vibration.....20 G (1 % ΔTR; 1 % ΔVR)

Shock.....100 G (1 % ΔTR; 1 % ΔVR)

Load Life
RJ24.....1,000 hours 0.5 watt @ 85 °C
(2 % ΔTR; 10 % ΔVR)
RJR24.....10,000 hours 0.5 watt @ 85 °C
(3 % ΔTR)

Rotational Life.....200 cycles (2 % ΔTR)

Physical Characteristics

Torque.....5.0 oz-in. max.

Mechanical Stops.....Wiper idles

Terminals.....Mil-Std 202, Method 208

Weight.....0.025 oz.

Marking.....Mil-spec part number, date code

Wiper.....50 % (Actual TR) ±10 %

Flammability.....U.L. 94V-0

Standard Packaging.....50 pcs. per tube

Adjustment Tool.....H-90

Product Dimensions

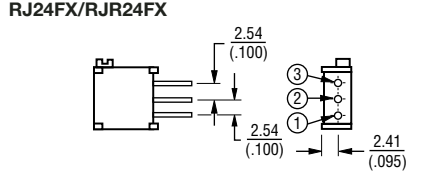
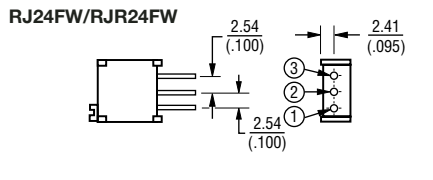
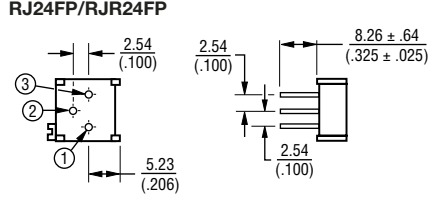
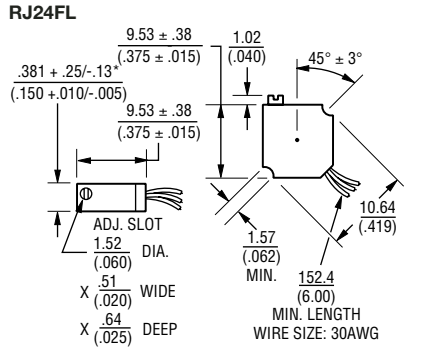
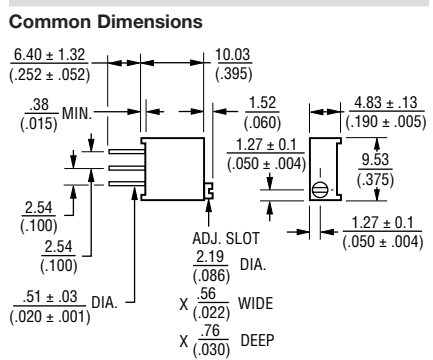

DIMENSIONS: MM/(INCHES)
TOLERANCES: ±.25/(±.010) EXCEPT WHERE NOTED

Standard Resistance Table

Resistance (Ohms)	Resistance Code
10	100
20	200
50	500
100	101
200	201
500	501
1,000	102
2,000	202
5,000	502
10,000	103
20,000	203
25,000	253
50,000	503
100,000	104
200,000	204
250,000	254
500,000	504
1,000,000	105

RJ24 – How To Order

MIL-PRF-22097 **RJ24 F L 202**

Model _____

Characteristic _____
F = ±100 ppm/°C Temp. Coeff. Max.

Terminal Style _____

Resistance Code _____

RJR24 – How To Order

MIL-PRF-39035 **RJR24 F W 502 R**

Model _____

Characteristic _____
F = ±100 ppm/°C Temp. Coeff. Max.

Terminal Style _____

Resistance Code _____

Failure Rate _____
M = 1.0 %
P = 0.1 %
R = 0.01 %

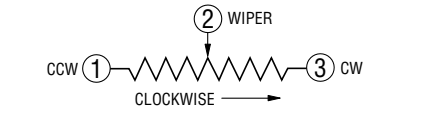

*"Fluorinert" is a registered trademark of 3M Co.
Specifications are subject to change without notice.
Customers should verify actual device performance in their specific applications. REV 09/04

Military Trimmers

AVAILABLE THROUGH DISTRIBUTION

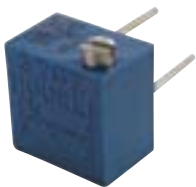

BOURNS®

RJ26/RJR26 1/4" Trimming Potentiometer

Features

- Multiturn / Cermet / Industrial / Sealed
- Listed on the QPL per MIL-R-22097 and High-Rel MIL-R-39035
- Patent #4427966 drive mechanism

Electrical Characteristics

Standard Resistance Range10 to 1 megohm
(see standard resistance table)
Resistance Tolerance±10 % std.
(tighter tolerance available)
Absolute Minimum Resistance1 % or
2 ohms max. (whichever is greater)
Contact Resistance Variation.....3.0 % or
3 ohms max. (whichever is greater)
Adjustability
Voltage±0.02 %
Resistance±0.05 %
Resolution.....Infinite
Insulation Resistance500 vdc
1,000 megohms min.
Dielectric Strength
Sea Level600 vac
80,000 Feet.....250 vac
Effective Travel.....12 turns nom.

Environmental Characteristics

Power Rating (200 volts max.)
85 °C0.25 watt
150 °C0 watt
Temperature Range.....-65 °C to +150 °C
Temperature Coefficient±100 ppm/°C
Seal Test85 °C Fluorinert*
Humidity
RJ26MIL-STD-202 Method 106
96 hours (1 % ΔTR, 10 Megohms IR)
RJ26MIL-STD-202 Method 106
96 hours (1 % ΔTR, 100 Megohms IR)
Vibration20 G (1 % ΔTR; 1 % ΔVR)
Shock100 G (1 % ΔTR; 1 % ΔVR)
Load Life
RJ261,000 hours 0.25 watt @ 85 °C
(2 % ΔTR; 1 % ΔVR)
RJ26 ...10,000 hours 0.25 watt @ 85 °C
(3 % ΔTR)
Rotational Life.....200 cycles
(2 % ΔTR)

Physical Characteristics

Torque3.0 oz-in. max.
Mechanical StopsWiper idles
Terminals.....MIL-STD-202; Method 208
Weight0.015 oz.
MarkingMil-spec part number
Wiper.....50 % (Actual TR) ±10 %
Flammability.....U.L. 94V-0
Standard Packaging50 pcs. per tube
Adjustment ToolH-90

Product Dimensions

RJ26FW/RJR26FW Common Dimensions

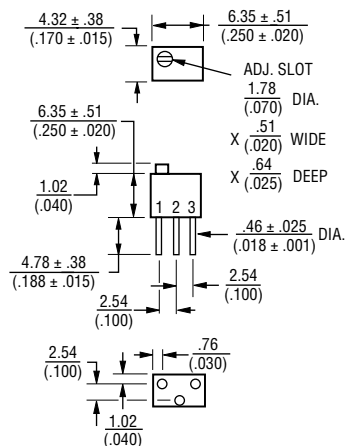

RJ26FX/ RJ26FX

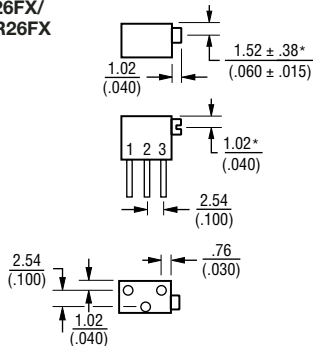

RJ26FP/ RJ26FP

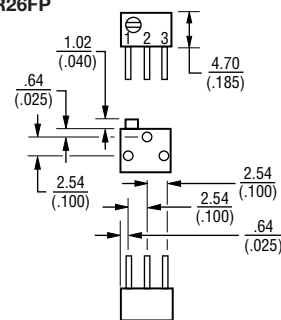

DIMENSIONS: MM/(INCHES)
TOLERANCES: ±.25/(±.010) EXCEPT WHERE NOTED

Standard Resistance Table

Resistance (Ohms)	Resistance Code
10	100
20	200
50	500
100	101
200	201
500	501
1,000	102
2,000	202
5,000	502
10,000	103
20,000	203
25,000	253
50,000	503
100,000	104
200,000	204
250,000	254
500,000	504
1,000,000	105

RJ26 - How To Order

MIL-PRF-22097 RJ26 F W 202
Model _____
Characteristic _____
F = ±100 ppm/°C Temp. Coeff. Max.
Terminal Style _____
Resistance Code _____

RJR26 - How To Order

MIL-PRF-39035 RJR26 F W 204 P
Model _____
Characteristic _____
F = ±100 ppm/°C Temp. Coeff. Max.
Terminal Style _____
Resistance Code _____
Failure Rate
M = 1.0 %
P = 0.1 %
R = 0.01 %

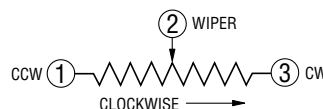

*"Fluorinert" is a registered trademark of 3M Co.
Specifications are subject to change without notice.
Customers should verify actual device performance in
their specific applications. REV 09/04

AVAILABLE THROUGH DISTRIBUTION

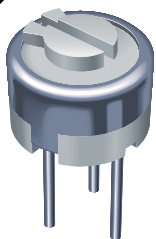

BOURNS®

RJ50/RJR50 1/4 " Round Trimming Potentiometer

Features

- 1/4 " Round / Single-Turn / Cermet Industrial / Sealed
- Listed on the QPL per MIL-PRF-22097 and High-Rel MIL-PRF-39035

Electrical Characteristics

Standard Resistance Range10 to 1 megohm (see standard resistance table)
 Resistance Tolerance±10 % std. (closer tolerance available)
 Absolute Minimum Resistance1 % or 2 ohms (whichever is greater)
 Contact Resistance Variation3.0 % or 3 ohms max. (whichever is greater)
 Adjustability
 Voltage±0.05 %
 Resistance±0.15 %
 ResolutionInfinite
 Insulation Resistance500 vdc
 1,000 megohms min.
 Dielectric Strength
 Sea Level600 vac
 80,000 Feet250 vac
 Adjustment Angle240 ° nom.

Environmental Characteristics

Power Rating @ 85 °C (300 volts max.)0.5 watt
 Power Rating @ 150 °C0 watt
 Temperature Range-55 °C to +150 °C
 Temperature Coefficient±100 ppm/°C
 Seal Test85 °C Fluorinert*
 HumidityMIL-STD-202 Method 106
 96 hours
 (3 % ΔTR, 10 Megohms IR)
 Vibration30 G (1 % ΔTR; 1 % ΔVR) except "P" pin style
 Shock100 G (1 % ΔTR; 1 % ΔVR)
 Load Life1,000 hours 0.5 watt @ 85 °C (3 % ΔTR; 3 % CRV)
 Rotational Life200 cycles (4 % ΔTR; 4 % CRV)

Physical Characteristics

Mechanical Angle260 ° nom.
 Torque5.0 oz-in. max.
 Stop Strength5.0 oz -in. min.
 TerminalsSolderable pins
 Weight0.02 oz.
 MarkingManufacturer's trademark, resistance code, date code, manufacturer's model number and style
 Wiper50 % (Actual TR) ±10 %
 Standard Packaging50 pcs. per tube
 Adjustment ToolH-90

*"Fluorinert" is a registered trademark of 3M Co.
 Specifications are subject to change without notice.
 Customers should verify actual device performance in their specific applications. REV 09/04

Product Dimensions

RJ50FP/RJR50FP

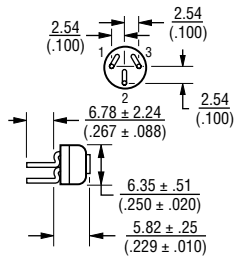

DIMENSIONS: MM/(INCHES)
 TOLERANCES: ±.25/(±.010) EXCEPT WHERE NOTED

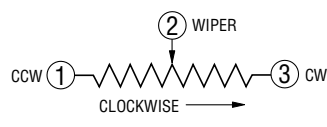

Standard Resistance Table

Resistance (Ohms)	Resistance Code
10	100
20	200
50	500
100	101
200	201
500	501
1,000	102
2,000	202
5,000	502
10,000	103
20,000	203
25,000	253
50,000	503
100,000	104
200,000	204
250,000	254
500,000	504
1,000,000	105

RJ50 – How To Order

MIL-PRF-22097 RJ50 F P 103
 Model _____
 Characteristic _____
 F = ±100 ppm/°C Temp. Coeff. Max.
 Terminal Style _____
 Resistance Code _____

RJR50 – How To Order

MIL-PRF-39035 RJR50 F P 203 P
 Model _____
 Characteristic _____
 F = ±100 ppm/°C Temp. Coeff. Max.
 Terminal Style _____
 Resistance Code _____
 Failure Rate _____
 M = 1.0 %
 P = 0.1 %

Military Trimmers

Linear Motion Potentiometers

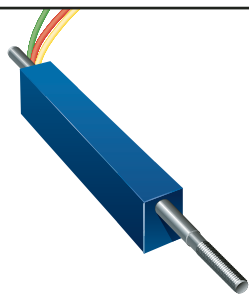

BOURNS®

3046 Linear Motion Potentiometer

Features

- Compact
- Sealed
- Long life
- Infinite resolution
- Free shaft rotation
- AC or DC
- Shaft options available
- Flexible wire leads
- Economical
- RoHS compliant†

Specifications*

Standard Electrical Travel
0.15, 0.25, 0.35 in.
 (3.81, 6.35, 8.89 mm)

Standard Resistances
1K to 50K ohms (±20 %)

Independent Linearity.....±5 %

Resolution.....Infinite

Power Rating @ 70 °C (158 °F)
0.125 watt

Operating Temperature Range
-55 °C to +125 °C

Temperature Coefficient.....1000 PPM/°C

Insulation Resistance.....50 megohms
 @ 500 VDC

Backlash.....Negligible

Shaft Actuating Force.....2N max. @21 °C

Life500,000 cycles

Shock.....50 G for 7ms

Vibration20 G, 10-2K Hz

Marking.....Manufacturer's trademark,
 resistance code, wiring diagram,
 date code, manufacturer's model
 number and style

*Specifications are typical.
 Contact factory for special requirements.
 *Specifications applicable from 5 % to 95 % of
 electrical travel.*

Standard Resistance Table

Resistance (Ohms)	Resistance Code
1,000	102
2,500	252
5,000	502
10,000	103
20,000	203
50,000	503

How To Order

3046 L - 2 - 502

Model _____

Style _____

Range (Travel) _____

1 = 0.15" (3.81 mm)

2 = 0.25" (6.35 mm)

3 = 0.35" (8.89 mm)

Resistance Code _____

*Specifications are subject to change without notice.
 †RoHS Directive 2002/95/EC Jan 27 2003 including Annex.
 Customers should verify actual device performance in
 their specific applications.*

REV 09/04

Product Dimensions

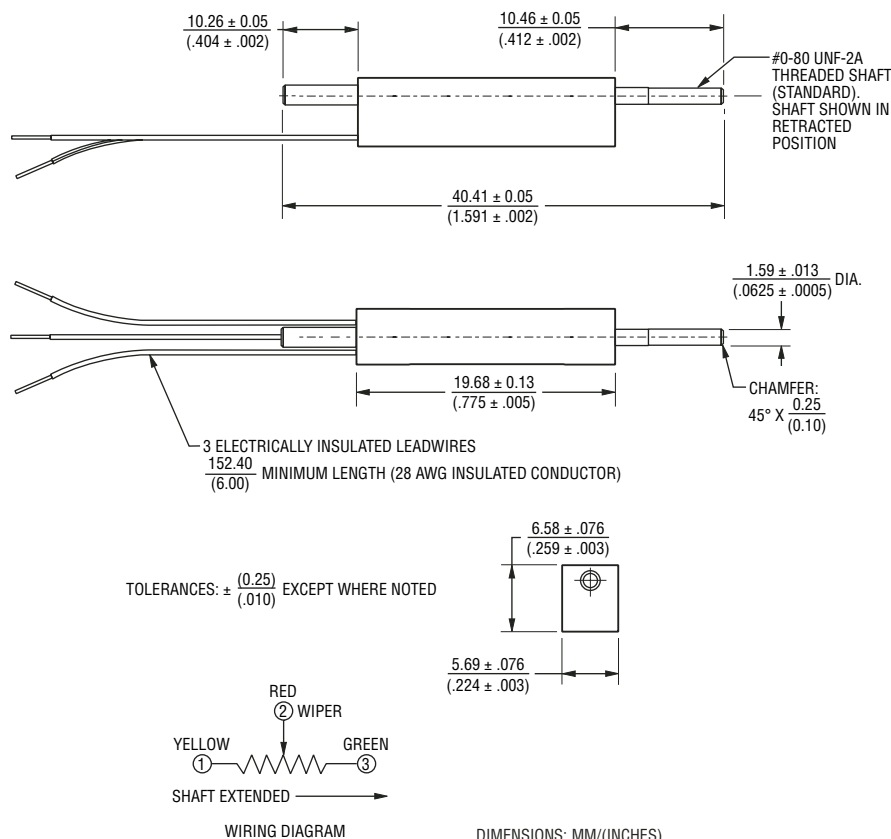

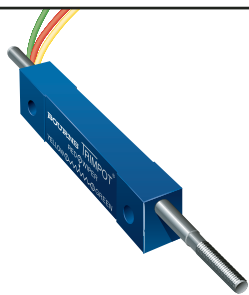

BOURNS®

3048 Linear Motion Potentiometer

Features

- Compact
- Lightweight
- Long life
- Infinite resolution
- Free shaft rotation
- AC or DC
- Shaft options available
- Flexible wire leads
- Economical
- RoHS compliant*

Specifications*

Standard Electrical Travel
0.2, 0.3, 0.4, 0.5 in.
 (5.08, 7.62, 10.16, 12.70 mm)

Standard Resistances
1K ohms to 50K ohms ($\pm 20\%$)

Independent Linearity..... $\pm 5\%$

Resolution.....Infinite

Power Rating @ 70 °C (158 °F)
 Range 2, 30.12 watt
 Range 4, 50.25 watt

Operating Temperature Range
-55 °C to +125 °C

Temperature Coefficient.....1000 PPM/°C

Insulation Resistance.....50 megohms
 @ 500 VDC

Backlash.....Negligible

Shaft Actuating Force4 oz. max.
 @ 70 °F

Life500,000 cycles

Shock.....50 G for 7 msec

Vibration.....20 G, 10-2 kHz

Marking.....Manufacturer's trademark,
 resistance code, wiring diagram,
 date code, manufacturer's model
 number and style

Specifications are typical.

Contact factory for special requirements.

**Specifications applicable from 5% to 95% of electrical travel.*

Standard Resistance Table

Resistance (Ohms)	Resistance Code
1,000	102
2,500	252
5,000	502
10,000	103
20,000	203
50,000	503

How To Order

3048 L - 2 - 502

Model _____

Style _____

Range (Travel) _____
 2 = 0.2" (5.08 mm)
 3 = 0.3" (7.62 mm)
 4 = 0.4" (10.16 mm)
 5 = 0.5" (12.70 mm)

Resistance Code _____

Product Dimensions

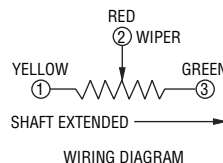
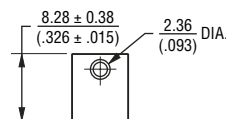
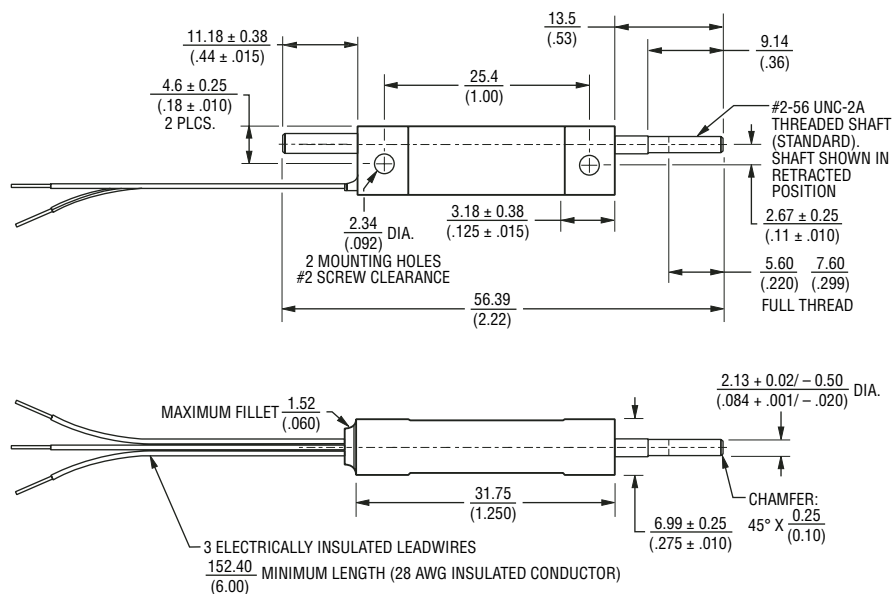

TOLERANCES: $\pm \frac{0.25}{(.010)}$ EXCEPT WHERE NOTED

DIMENSIONS: MM/(INCHES)

Specifications are subject to change without notice.

**RoHS Directive 2002/95/EC Jan 27 2003 including Annex. Customers should verify actual device performance in their specific applications.*

REV 09/04

Modular Contacts



70AA/Female Modular Contact

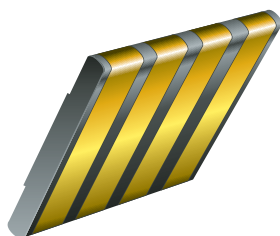

BOURNS®

Features

- 2.54 mm pitch & height
- 2 to 6 precious metal contacts
- End-to-end stackable
- Twin hot contacts (symmetrical pad layout)
- Pick & place compatible
- High cycle life
- RoHS compliant†

Applications

- Handheld communications – mobile phones, pagers, cordless phones, GPS, PICs, radios
- Portable consumer equipment – PDAs, HPCs, notebook PCs, cameras, dictaphones, PICs, games
- Component-to-board, SIM cards, etc.

Materials & Finishes

InsulatorGlass reinforced thermoplastic, UL 94V-0 rated, black
 ContactCopper alloy
 Finish
 Underplating30 μ" - 60 μ" nickel
 Contact Area.....30 μ" Au over nickel

Operating Characteristics

Electrical
 Current Rating3 A/contact
 Voltage Rating60 V
 Contact Resistance30 mohms max.
 Dielectric VoltageAC 500 V
 Insulating Resistance ..1000 Mohms min.
 Operating Temperature
-55 °C to 125 °C

Mechanical
 Durability10,000 cycles min.

How To Order

70AA J - 4 - F 0 G

Model _____
 Terminal Style _____
 J = SMT
 Number of Contacts (N) _____
 2 through 6
 Gender _____
 F = Female
 Options _____
 0 = Standard
 1 = Locating Pins
 Packaging Option _____
 — = Tube (240/N pcs. or 240 contacts per tube)
 G = Embossed Tape (750 pcs. per reel)

Product Dimensions

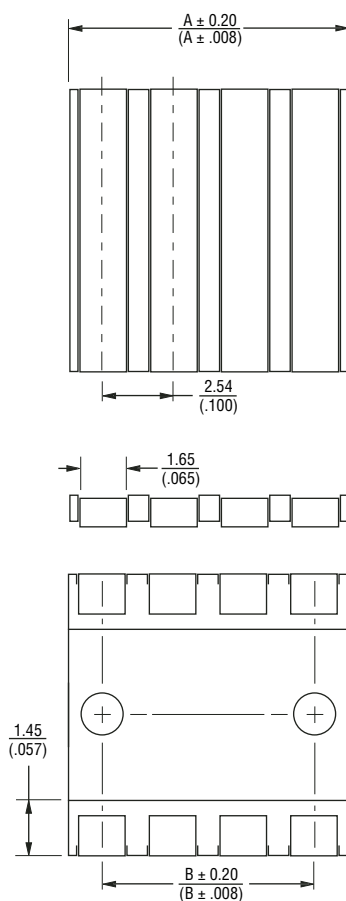

DIMENSIONS: MM/(INCHES)
 TOLERANCES: ±.3/(±.012) EXCEPT WHERE NOTED

Number of Contacts	Dimension A	Dimension B
2	4.98 (.196)	2.54 (.100)
3	7.52 (.296)	5.08 (.200)
4	10.06 (.396)	7.62 (.300)
5	12.60 (.496)	10.16 (.400)
6	15.14 (.596)	12.70 (.500)

Standard Version (-0)

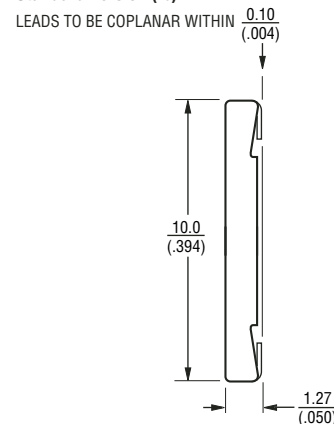

Locating Pins Version (-1)

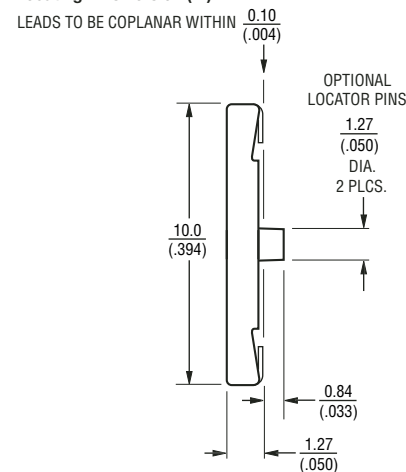

Recommended PWB Layout

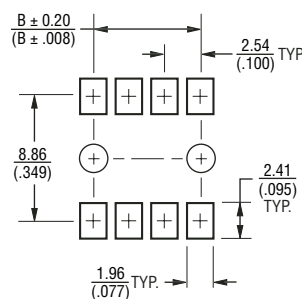

Specifications are subject to change without notice.
 †RoHS Directive 2002/95/EC Jan 27 2003 including Annex.
 Customers should verify actual device performance in their specific applications.
 REV 09/04

70AA/Male Modular Contact

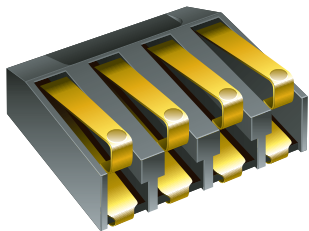

BOURNS®

Features

- 2.54 mm pitch & height
- 2 to 6 precious metal contacts
- End-to-end stackable
- Twin hot contacts (symmetrical pad layout)
- Pick & place compatible
- High cycle life
- RoHS compliant†

Applications

- Handheld communications – mobile phones, pagers, cordless phones, GPS, PICs, radios
- Portable consumer equipment – PDAs, HPCs, notebook PCs, cameras, dictaphones, PICs, games
- Component-to-board, SIM cards, etc.

Materials & Finishes

InsulatorGlass reinforced thermoplastic, UL 94V-0 rated, black
 ContactCopper alloy
 Finish
 Underplating30 μ" - 60 μ" nickel
 Contact Area.....30 μ" Au over nickel

Operating Characteristics

Electrical

Current Rating3 A/contact
 Voltage Rating60 V
 Contact Resistance25 mΩ max.
 Dielectric VoltageAC 500 V
 Insulating Resistance1000 MΩ min.
 Operating Temperature...-55 °C to 125 °C

Mechanical

Normal Force/Finger80 grams min.
 Durability10,000 cycles min.

How To Order

70AA J - 4 - M 0 G

Model _____
 Terminal Style _____
 J = SMT
 Number of Contacts (N) _____
 2 through 6
 Gender _____
 M = Male
 Options _____
 0 = Standard
 Packaging Option _____
 = Tube
 G = Embossed Tape
 (750 pcs. per reel)

Product Dimensions

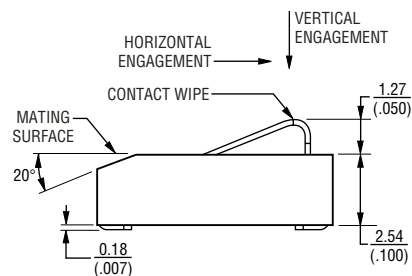
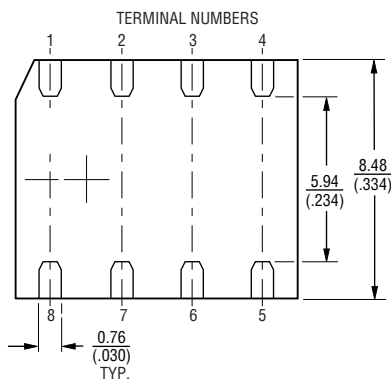
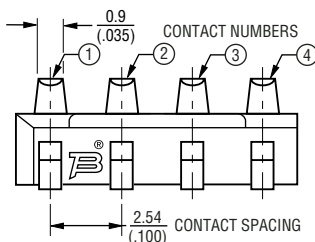
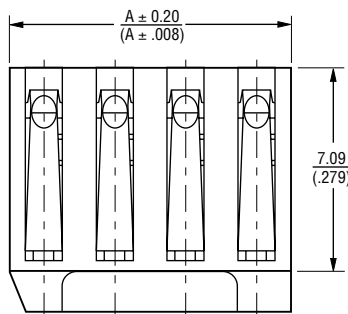

Recommended PWB Layout

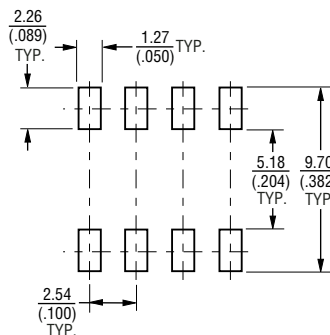

Electrical Schematic

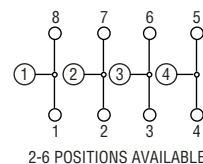

DIMENSIONS: MM/(INCHES)
 TOLERANCES: ±.3/(±.012) EXCEPT WHERE NOTED

Number of Contacts	Dimension A
2	5.00 / (.197)
3	7.54 / (.297)
4	10.20 / (.397)
5	12.62 / (.497)
6	15.16 / (.597)

Specifications are subject to change without notice.
 †RoHS Directive 2002/95/EC Jan 27 2003 including Annex.
 Customers should verify actual device performance in their specific applications. REV 09/04

70AA/Male – Packaging Specifications

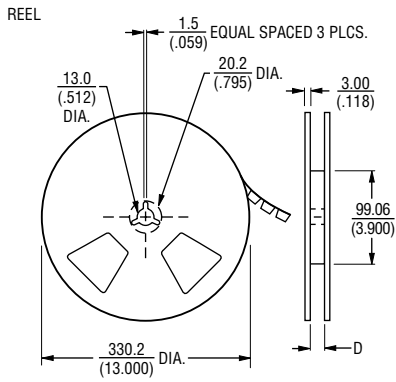
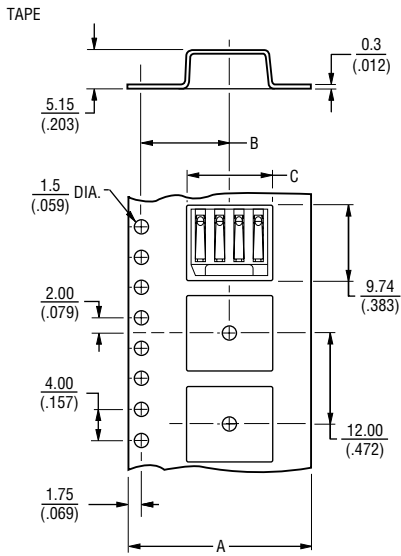

Number of Contacts	Dimension A	Dimension B	Dimension C	Dimension D
2	16.0 (.630)	7.5 (.296)	5.64 (.222)	16.4 (.646)
3	16.0 (.630)	7.5 (.296)	8.19 (.323)	16.4 (.646)
4	24.0 (.945)	11.5 (.453)	10.4 (.409)	24.4 (.961)
5	24.0 (.945)	11.5 (.453)	12.95 (.510)	24.4 (.961)
6	24.0 (.945)	11.5 (.453)	15.5 (.610)	24.4 (.961)

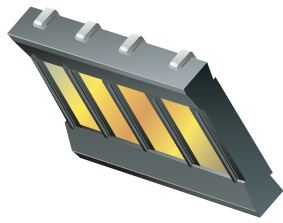

BOURNS®

70AD/Female Modular Contact

Features

- Rechargeable battery-pack applications
- Precious metal contacts
- Tape & reel packaging available
- RoHS compliant†

Materials & Finishes

InsulatorGlass reinforced thermoplastic, UL 94V-0 rated, black
 ContactCopper alloy
 Finish
 Underplating30 μ" - 60 μ" nickel
 Contact Area.....30 μ" Au over nickel
 Termination.....Tin alloy
 (meets MIL-STD-202, method 208)

Operating Characteristics

Electrical

Current RatingDC 3 A/contact
 Voltage Rating.....DC 30 V
 Contact Resistance25 mΩ max.
 Dielectric VoltageAC 500 V
 Insulating Resistance500 MΩ min.
 Operating Temperature....-55 °C to 125 °C

Mechanical

Durability5,000 cycles

How To Order

70AD J - 3 - F L O G

Model _____
 Terminal Style
 J = SMT
 H = Through-hole
 Number of Contacts
 2 through 6
 Gender
 M = Male
 F = Female
 Height
 L = Low Profile
 Options
 0 = Standard
 1 = Locator Pins (J style only)
 Packaging Option
 — = Tube (240/N pcs. or 240 contacts per tube)
 G = Embossed Tape (500 pcs. per reel)

No. of Contacts	Dim. A	Dim. B	Dim. C
2	9.0 (.354)	4.0 (.157)	7.0 (.276)
3	13.0 (.512)	8.0 (.315)	11.0 (.433)
4	17.0 (.669)	12.0 (.472)	15.0 (.591)
5	21.0 (.827)	16.0 (.630)	19.0 (.748)
6	25.0 (.984)	20.0 (.787)	23.0 (.906)

Product Dimensions

70ADJ

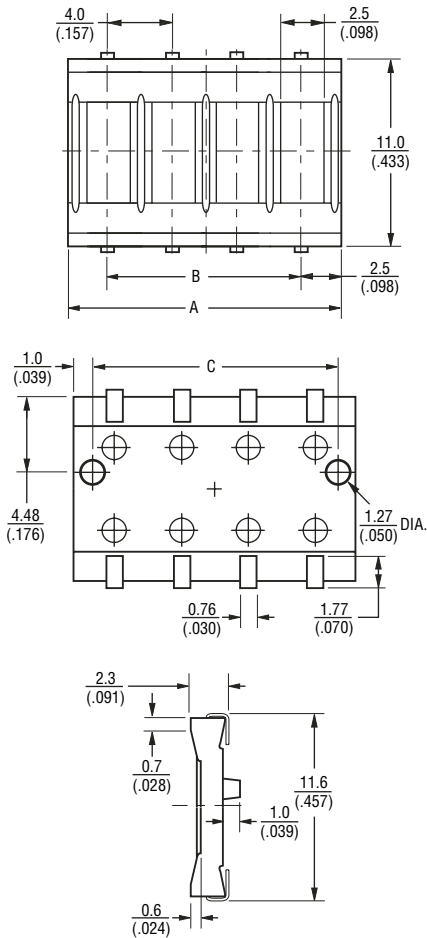

70ADJ RECOMMENDED PWB MOUNTING PATTERN

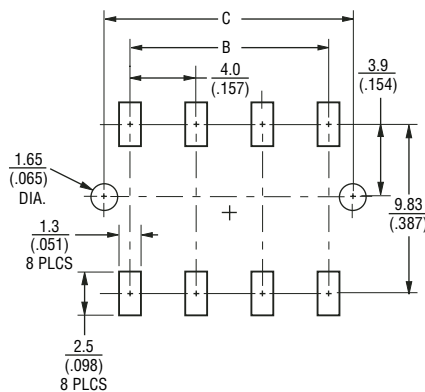

70ADH

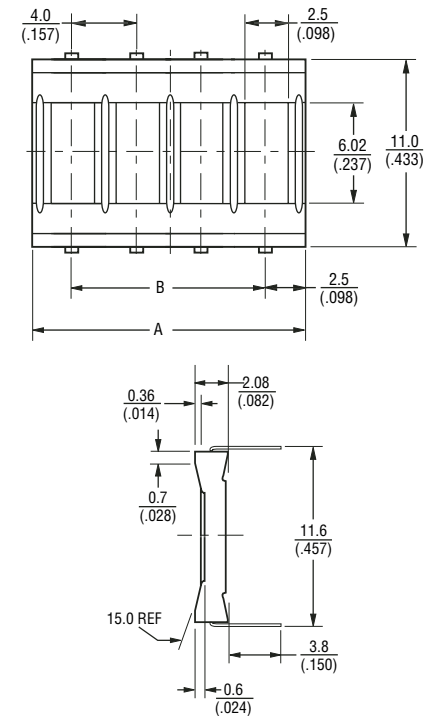

70ADH RECOMMENDED PWB MOUNTING PATTERN

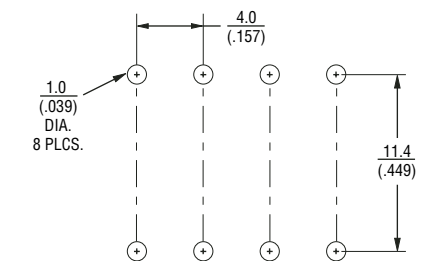

DIMENSIONS: MM/(INCHES)
 TOLERANCES: ±.3/(±.012) EXCEPT WHERE NOTED

Specifications are subject to change without notice.
 †RoHS Directive 2002/95/EC Jan 27 2003 including Annex.
 Customers should verify actual device performance in their specific applications.
 REV 09/04

Modular Contacts

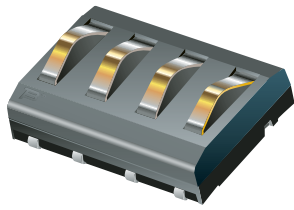

BOURNS®

70AD/Male Modular Contact

Features

- Low profile
- Rugged design
- Vertical or horizontal entry
- Tape & reel packaging available
- RoHS compliant*

Modular Contacts

Materials & Finishes

InsulatorGlass reinforced thermoplastic
 UL 94V-0 rated, black
 ContactCopper alloy
 Finish
 Underplating30 μ" - 60 μ" nickel
 Contact Area30 μ" Au over Ni
 Termination.....Tin alloy
 (meets MIL-STD-202, method 208)

Operating Characteristics

Electrical
 Current RatingDC 3 A/contact
 Voltage Rating.....DC 30 V
 Contact Resistance25 mΩ max.
 Dielectric VoltageAC 500 V
 Insulating Resistance500 MΩ min.
 Operating Temperature
-55 °C to 125 °C

Mechanical
 Normal Force/Finger100 grams min.
 Durability5,000 cycles

Patent No. 5,378,160.

How To Order

70AD J - 3 - M L 0 G

Model _____
 Terminal Style
 J = SMT
 H = Through-hole
 Number of Contacts _____
 2 through 6
 Gender
 M = Male
 F = Female
 Height
 L = Low Profile
 Options
 0 = Standard
 1 = Locator Pins (J style only)
 Packaging Option
 - = Tube (240/N pcs. or
 240 contacts per tube)
 G = Embossed Tape
 (500 pcs. per reel)

Number of Contacts	Dimension A	Dimension B
2	7.7 / (.303)	5.11 / (.201)
3	11.7 / (.461)	9.11 / (.359)
4	15.7 / (.618)	13.11 / (.516)
5	19.7 / (.776)	17.11 / (.674)
6	23.7 / (.933)	21.11 / (.831)

Product Dimensions

70ADJ

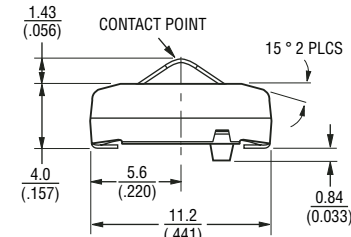
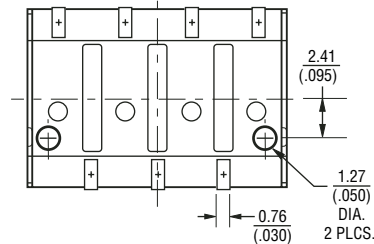
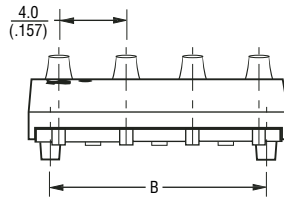
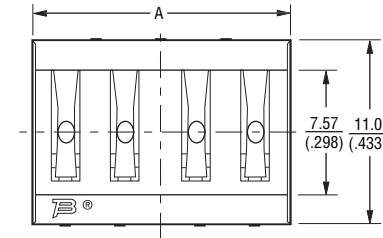

RECOMMENDED PWB MOUNTING PATTERN

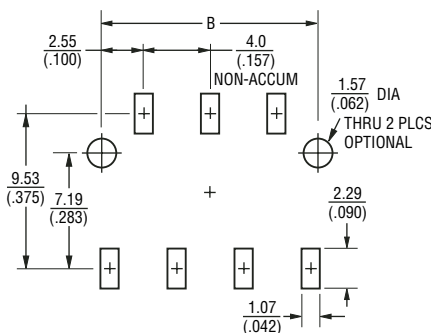

70ADH

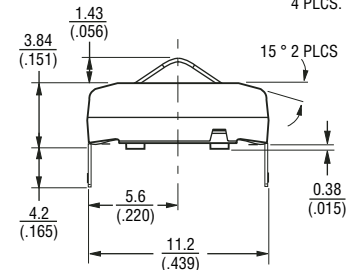
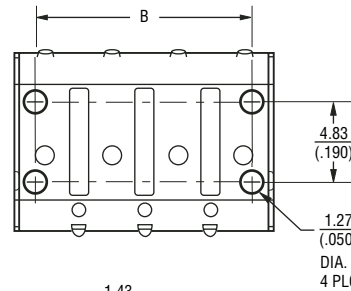
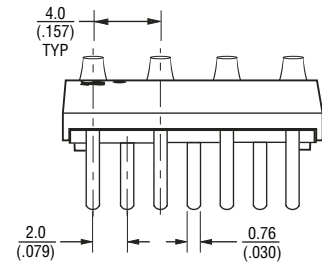

RECOMMENDED PWB PCB HOLE PATTERN

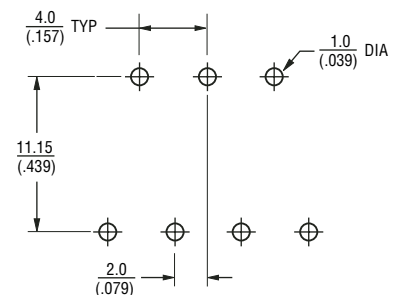

DIMENSIONS: MM/(INCHES)
 TOLERANCES: ±.3/(±.012) EXCEPT WHERE NOTED

Specifications are subject to change without notice.
 *RoHS Directive 2002/95/EC Jan 27 2003 including Annex.
 Customers should verify actual device performance in
 their specific applications. REV 09/04

Switches



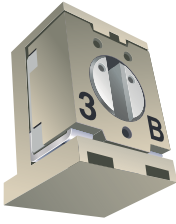

BOURNS®

7813 SMD 3 mm Square Sealed Rotary Switch

Features

- Single pole/double throw
- Compatible with most surface mount manufacturing processes
- 50 or 2000 cycle rotational life
- Tape & reel packaged
- Withstands 245 ° soldering heat
- RoHS compliant*

Electrical Characteristics

Contact Rating
 Maximum Current100 mA max.
 Maximum Voltage16 V
 Contact Timing.....Non-shorting
 Contact Resistance.....2 ohms max.
 Insulation Resistance
100 megohms min.
 Dielectric Strength250 VAC

General Characteristics

Switch Type.....SPDT
 Operating Temperature Range
-55 °C to +125 °C
 Storage Temperature Range
-55 °C to +125 °C
 Seal Test.....85 °C Fluorinert*

Mechanical Characteristics

Positions.....2
 Adjustment Torque......5 N-cm max.
 Stop Strength.....1.8 N-cm min.

Environmental Characteristics

Shock20 G
 0.1 ms max. discontinuity
 Vibration100 G
 0.1 ms max. discontinuity
 Thermal Shock.....(5 cycles)
 -55 °C to +125 °C
 Humidity
 Insulation Resistance
10 megohms min.
 Rotational Life
 -05150 Cycles
 -0232000 Cycles
 Max. Soldering Heat245 °C,
 5 seconds

Standard Packaging

J1,000 pcs./reel
 S200 pcs./reel

How To Order

7813 J - 1 - 051 E

Model _____
 Terminal _____
 Switch Type _____
 -1 = SPDT
 Rotational Life _____
 -051 = 50 Cycles
 -023 = 2000 Cycles
 Embossed Tape Designator _____
 E = 1000 pcs./180 mm Reel (J Style)
 200 pcs./180 mm Reel (S Style)

Product Dimensions

7813J

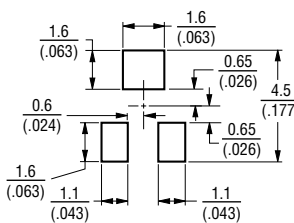
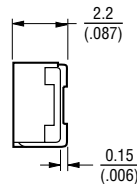
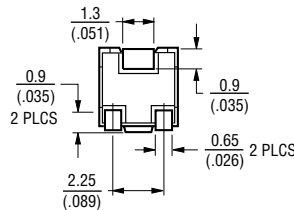
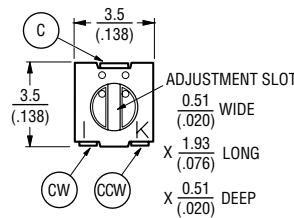

DIMENSIONS: MM/(INCHES)
 TOLERANCES: ±.2/(±.007) EXCEPT WHERE NOTED

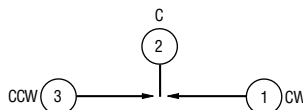

7813S

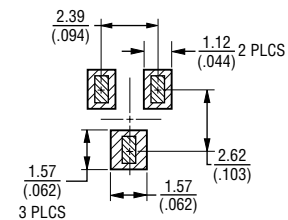
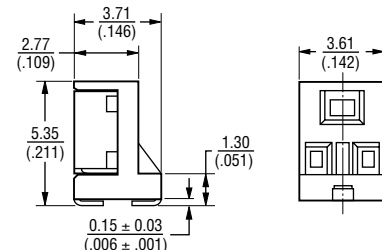
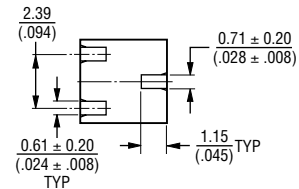
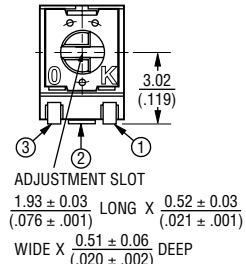

RECOMMENDED
 LAND PATTERN

U.S. Patent No. 5043695
 *"Fluorinert" is a registered trademark of 3M Co.
 *RoHS Directive 2002/95/EC Jan 27 2003 including Annex.
 Specifications are subject to change without notice.
 Customers should verify actual device performance in
 their specific applications. REV 09/04

7813 – Packaging Specifications and Reflow Soldering Profile

Packaging Specifications

7813J

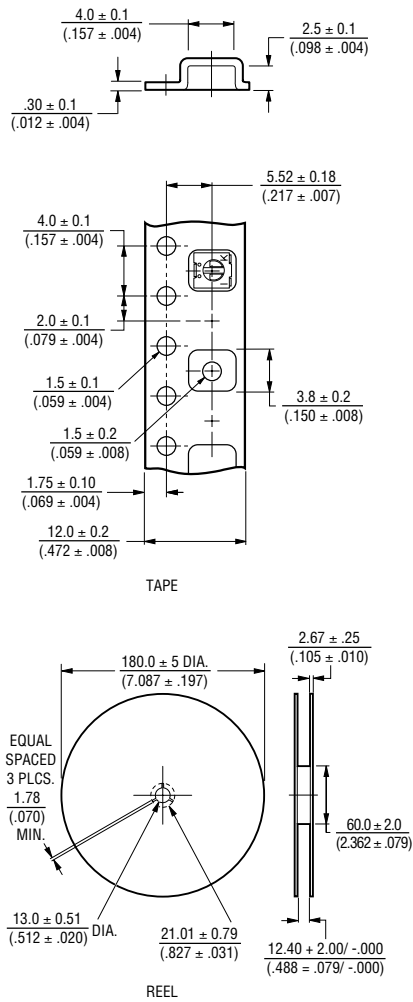

Meets EIA 481

7813S

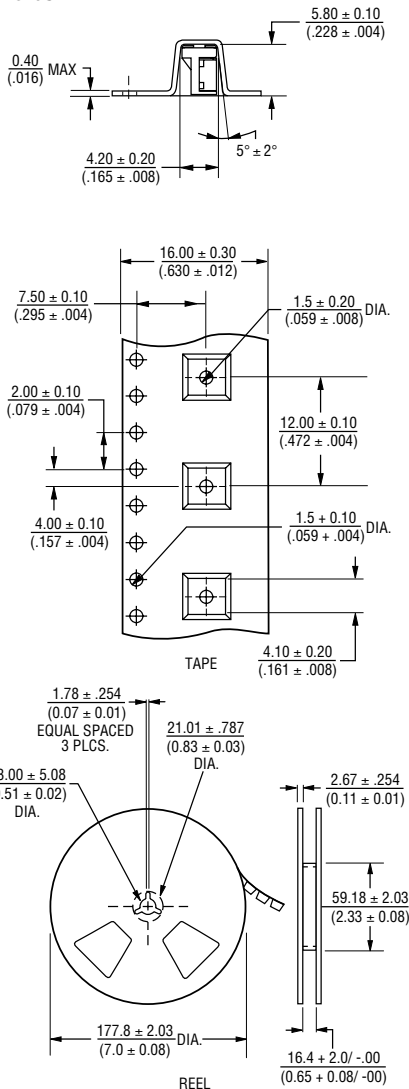

Meets EIA 481

Reflow Soldering Profile

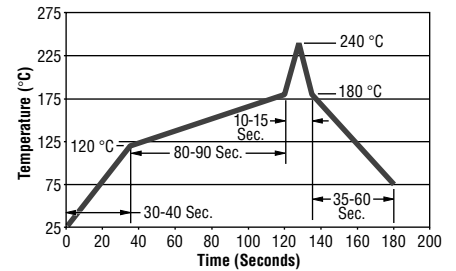

Specifications are subject to change without notice. Customers should verify actual device performance in their specific applications.

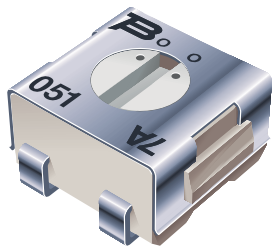

BOURNS®

7814 SMD 4 mm Square Sealed Rotary Switch

Features

- Single pole/double throw
- Compatible with most surface mount soldering processes
- 50 or 2000 cycle rotational life
- Compatible with popular vacuum pick-and-place equipment
- J-hook, gull-wing and through hole
- Meets EIA/EIAJ/IPC/VRCI SMD standard outline dimensions
- RoHS compliant†

Electrical Characteristics

Contact Rating
 Maximum Current100 mA max.
 Maximum Voltage16 V
 Contact Timing.....Non-shorting
 Contact Resistance.....2 ohms max.
 Insulation Resistance...100 megohms min.
 Dielectric Strength250 VAC

General Characteristics

Switch Type.....SPDT
 Operating Temperature Range
-55 °C to +125 °C
 Storage Temperature Range
-55 °C to +125 °C
 Seal Test.....85 °C Fluorinert*

Mechanical Characteristics

Positions.....2
 Adjustment Torque.....1.8 N-cm max.
 Stop Strength.....2.5 N-cm min.
 Pushover Strength (Z Style)
2 kilograms minimum
 Weight.....Approximately 0.2 gm.
 MarkingManufacturer's
 trademark, life code and date code

Environmental Characteristics

Vibration20 G
 Shock100 G
 Thermal Shock (5 cycles)..-55 °C to +125 °C
 Humidity
 Insulation Resistance....10 megohms min.
 Rotational Life
 -05150 Cycles
 -0232000 Cycles
 Max. Soldering Heat ...245 °C, 10 seconds
 Packaging Options
 J & G.....500 pcs.
 Z200 pcs.
 H.....100 pcs./tube

How To Order

7814 J - 1 - 051 E

Model _____
 Terminal _____
 J = J-Hook
 G = Gull Wing
 H = Through-hole
 Z = Right Angle
 Switch Type _____
 -1 = SPDT
 Rotational Life _____
 -051 = 50 Cycles
 -023 = 2000 Cycles
 Optional Embossed Tape Designator _____
 (For pin styles J, G, Z only –
 omit for tube packaging)

Product Dimensions

7814J J-Hook

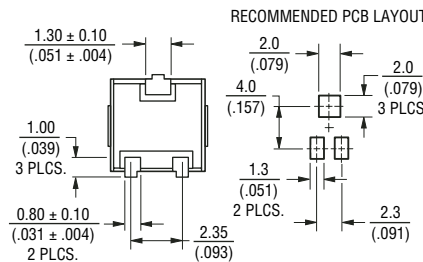
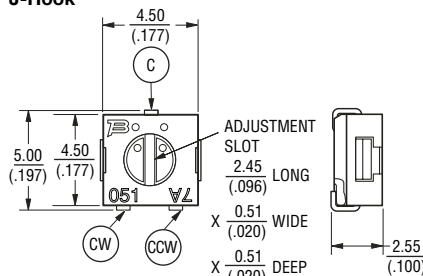

7814G Gull Wing

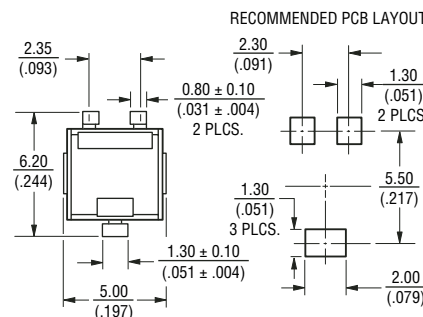
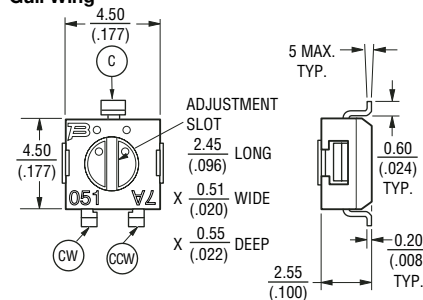

DIMENSIONS: MM/(INCHES)
 TOLERANCES: ±2/(±.007) EXCEPT WHERE NOTED

7814H Through-hole

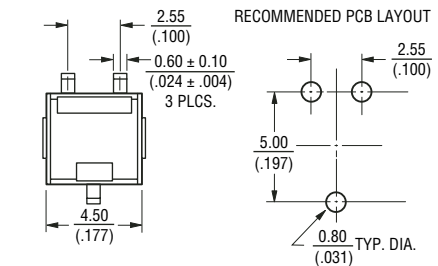
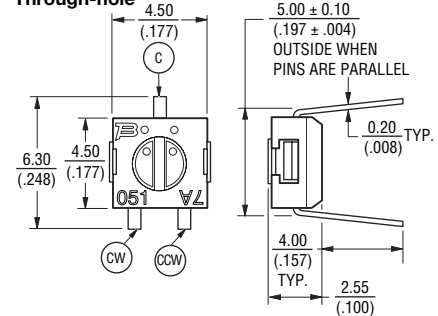

7814Z Right Angle

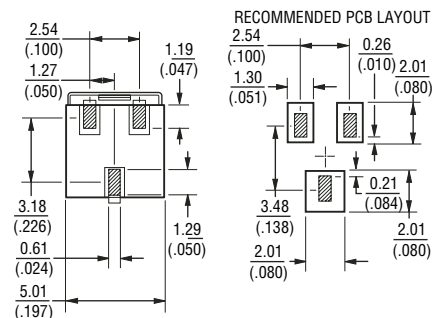
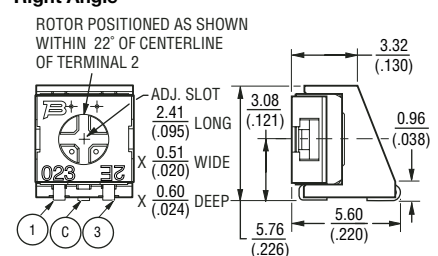

*"Fluorinert" is a registered trademark of 3M Co.
 †RoHS Directive 2002/95/EC Jan 27 2003 including Annex.
 Specifications are subject to change without notice.
 Customers should verify actual device performance in
 their specific applications. REV 09/04

7814 – Packaging Specifications and Reflow Soldering Profile

Packaging Specifications

J Style

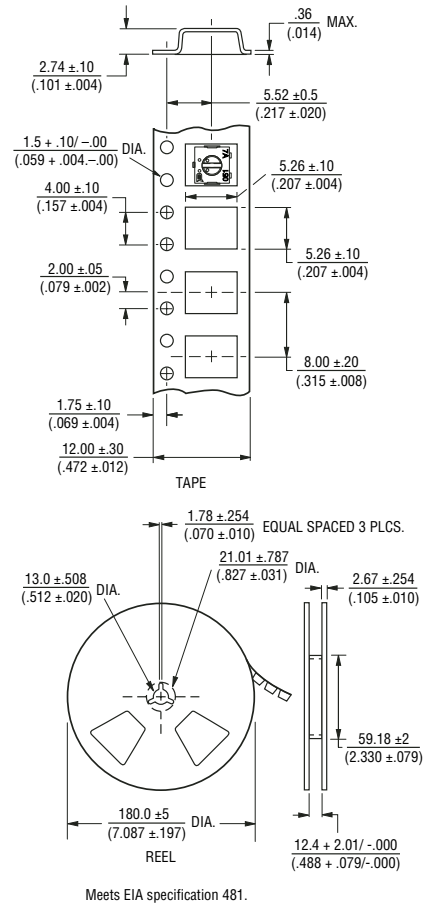

H Style

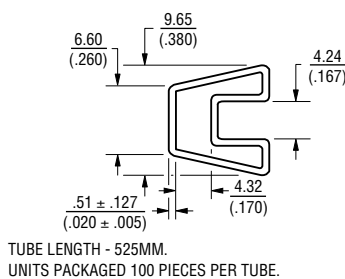

G Style

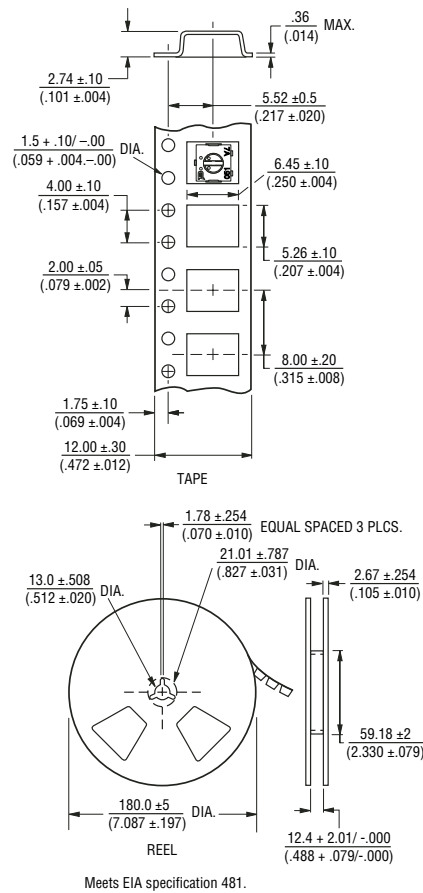

Reflow Soldering Profile

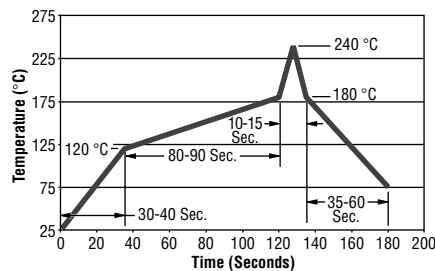

Z Style

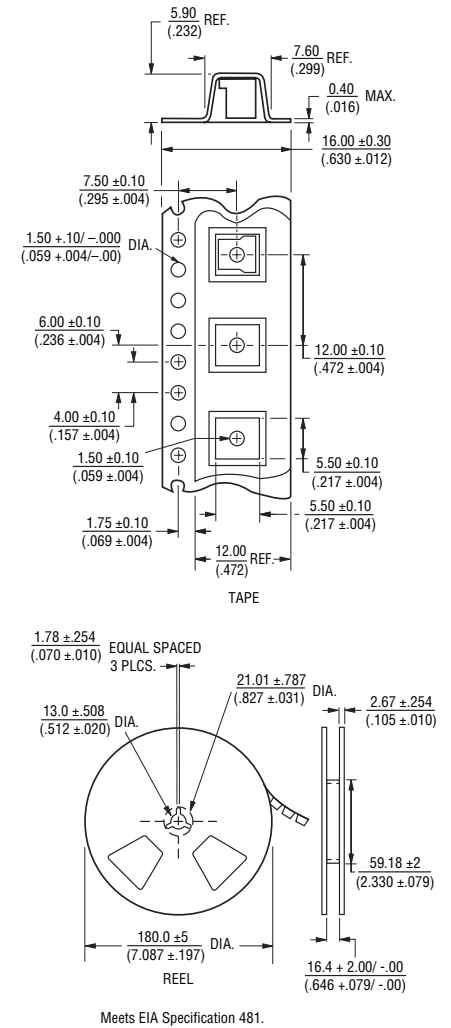

Electrical Schematic

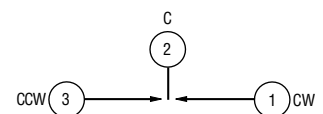

Specifications are subject to change without notice. Customers should verify actual device performance in their specific applications.

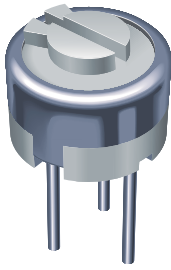

BOURNS®

7829 6 mm Through-hole Sealed Rotary Switch

Features

- Single pole/double throw
- Vertical adjust
- Rugged construction
- Board washable
- Wave solderable
- RoHS compliant†

Electrical Characteristics

Contact Rating
 Maximum Current100 mA max.
 Maximum Voltage16 V
 Contact Timing.....Non-shorting
 Contact Resistance.....2 ohms max.

General Characteristics

Switch Type.....SPDT
 Operating Temperature Range
-55 °C to +125 °C
 Storage Temperature Range
-55 °C to +125 °C
 Thermal Shock.....5 cycles
 -55 °C to +125 °C
 Seal Test......85 °C Fluorinert*

Mechanical Characteristics

Stop Strength3.5 N.cm
 Positions.....2

Environmental Characteristics

Vibration30 G
 Shock100 G
 Thermal Shock.....(5 cycles)
 -55 °C to +125 °C
 Humidity
 Insulation Resistance
10 megohms min.
 Rotational Life
 -05150 Cycles
 -0232000 Cycles
 Maximum Soldering Heat245 °C
 Standard Packaging50 pcs/tube

How To Order

7829 H - 1 - 051

Model _____
 Terminal _____
 Switch Type _____
 -1 = SPDT
 Rotational Life
 -051 = 50 Cycles
 -023 = 2000 Cycles

Electrical Schematic

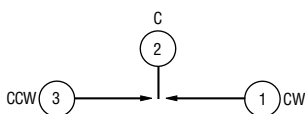

*"Fluorinert" is a registered trademark of 3M Co.
 †RoHS Directive 2002/95/EC Jan 27 2003 including Annex.
 Specifications are subject to change without notice.
 Customers should verify actual device performance in
 their specific applications. REV 09/04

Product Dimensions

7829H

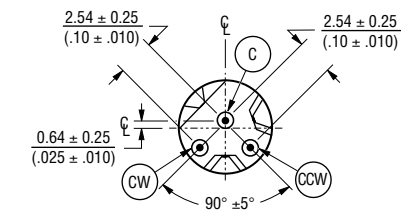
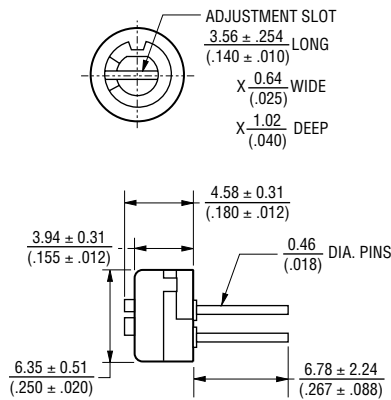

RECOMMENDED PCB LAYOUT

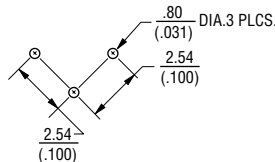

DIMENSIONS: MM/(INCHES)
 TOLERANCES: ±.2/(±.007) EXCEPT WHERE NOTED

Reflow Soldering Profile

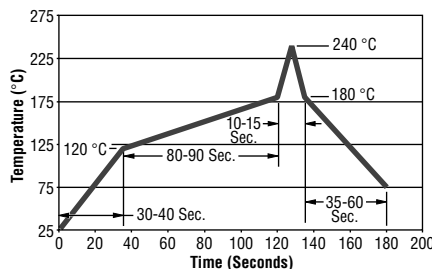

7829S

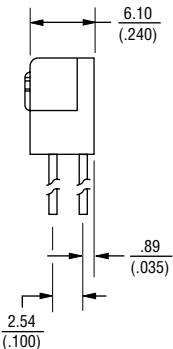
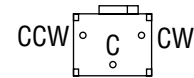
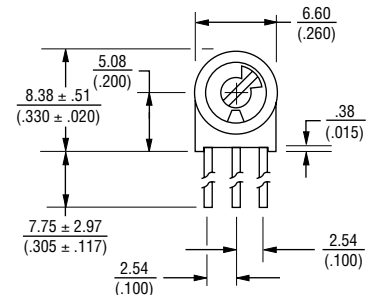

Packaging Specifications

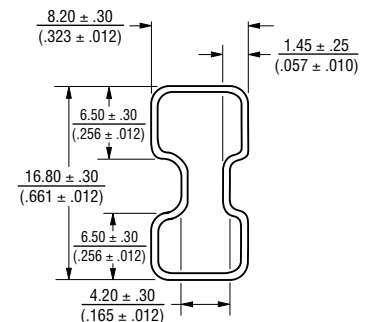

.TUBE LENGTH - 356 ± 1.50 MM.
 UNITS PACKAGED 50 PIECES PER TUBE.

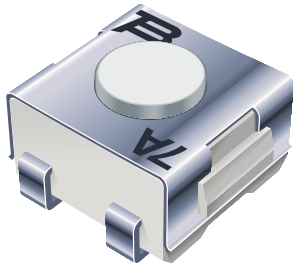

BOURNS®

7914 – 4 mm SMD & Through-hole Sealed Key Switch

Features

- Compatible with most surface mount soldering processes
- Compatible with popular vacuum pick-and-place equipment
- J-hook, gull-wing & pinned configurations
- Sealed for board washing
- Meets EIA/EIAJ/IPC/VRCI SMD standard outline dimensions
- Top or side actuated
- RoHS compliant*

Electrical Characteristics

Contact Rating

Maximum Current100 mA max.
 Maximum Voltage16 V
 Contact Resistance100 milliohms max.
 Insulation Resistance100 megohms min.
 Dielectric Strength250 VAC

General Characteristics

Switch TypeNormally open
 Operating Temp. Range ...-55 °C to +125 °C
 Storage Temp. Range ...-55 °C to +125 °C
 Seal Test85 °C Fluorinert*
 Vibration20 G
 Shock100 G

Mechanical Characteristics

Actuator Force300 ±100 g
 Pushover Strength (S Style)2 kG min.
 Cycle life, loaded100,000 actuations
 Contact resistance100 milliohms max.

Physical Characteristics

Cover MaterialStainless steel
 Base MaterialThermoplastic, UL 94V-0
 Terminal MaterialPhosphor bronze
 Dome MaterialStainless steel
 Actuator MaterialHigh temperature silicon rubber
 MarkingManufacturer's code and date code

Packaging Options

J & G500 pcs./reel; 50 pcs./tube
 S200 pcs./reel; 100 pcs./tube
 H50 pcs./tube

How To Order

7914 J - 1 - 000 E

Model _____
 Terminal _____
 J = J-Hook G = Gull Wing
 H = Through-hole Z = Right Angle
 Switch Type _____
 -1 = N.O. Au Contacts
 Product Code for Button Height _____
 (For Styles J, G, and H)
 -000 = 4.0 mm FMS
 -024 = 2.4 mm FMS (Flush Actuator)
 -032 = 3.2 mm FMS
 -050 = 5.0 mm FMS
 (For Style S)
 -000 = 1.68 mm FTS -032 = 0.91 mm FTS
 -024 = Flush Actuator -050 = 2.7 mm FTS
 Embossed Tape _____
 (Option applicable to Styles J, G & S only – Consult Factory. Omit for Tube packaging.)
 G, J = 500 pcs./reel S = 200 pcs./reel

FMS = From Mounting Surface
 FTS = From Top Surface

Product Dimensions

7914J J-Hook

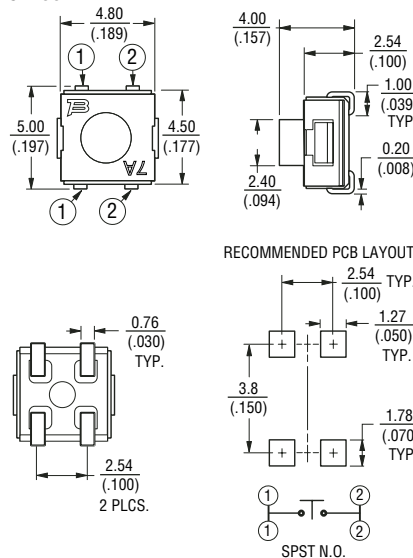

7914G Gull Wing

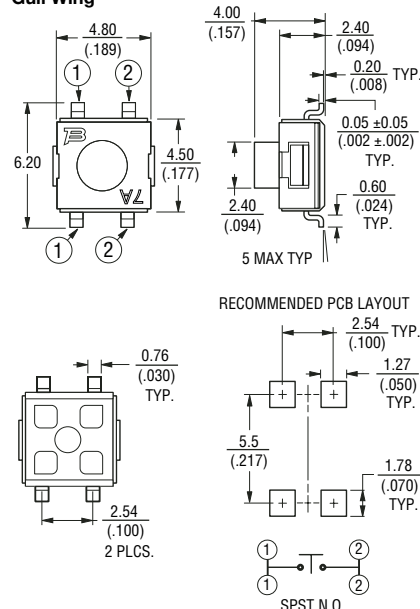

*"Fluorinert" is a registered trademark of 3M Co.
 *RoHS Directive 2002/95/EC Jan 27 2003 including Annex. Specifications are subject to change without notice. Customers should verify actual device performance in their specific applications.
 REV 09/04

7914H Through-hole

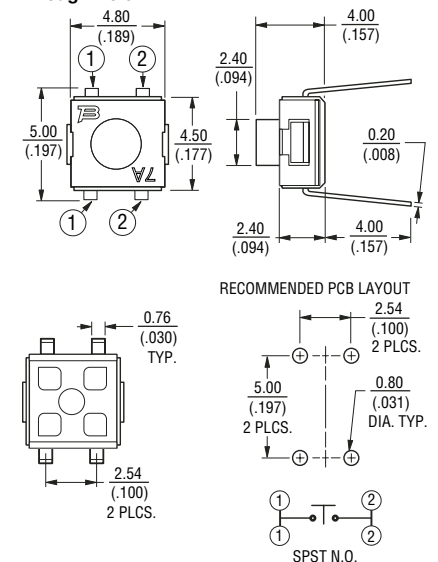

7914S Right Angle

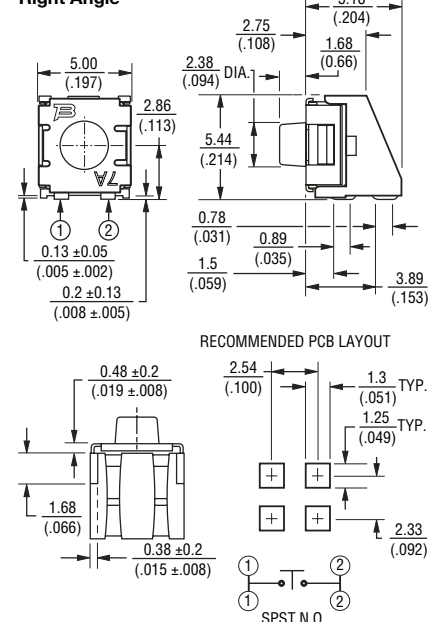

DIMENSIONS: MM/(INCHES)
 TOLERANCES: ±.2/(±.008) EXCEPT WHERE NOTED

7914 – Packaging Specifications

Switches

J Style Reel

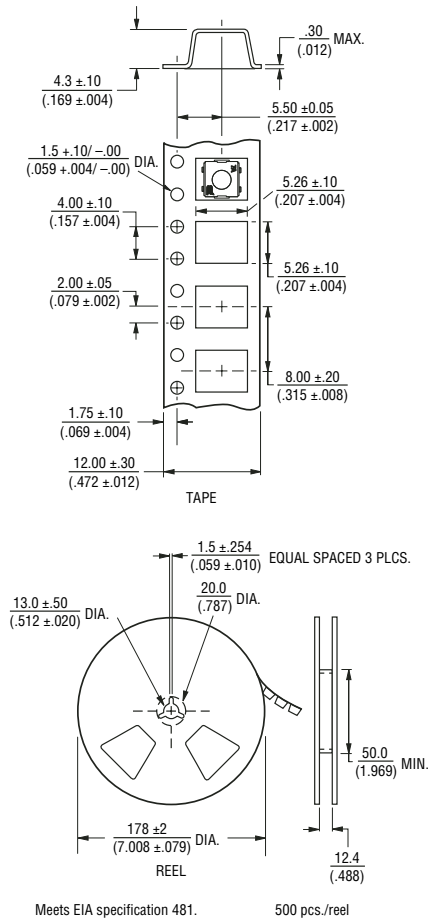

J/G Style Tube

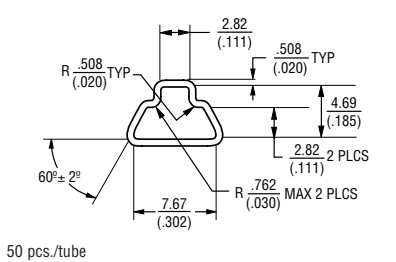

Specifications are subject to change without notice. Customers should verify actual device performance in their specific applications.

G Style Reel

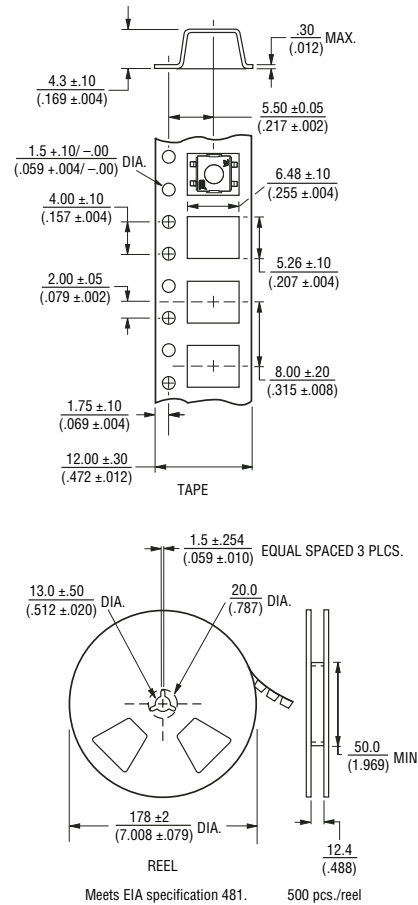

H Style Tube

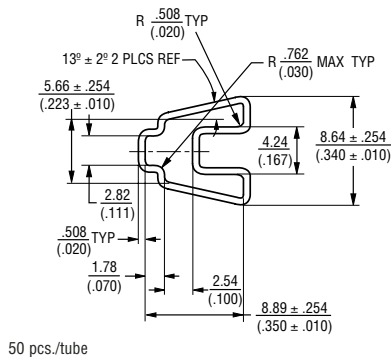

S Style Reel

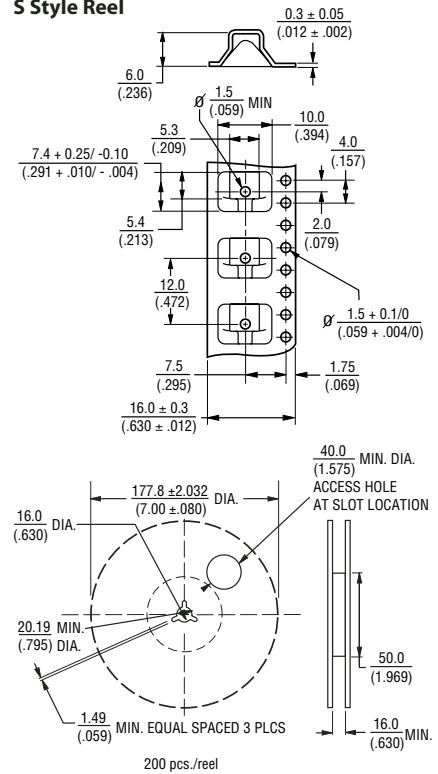

S Style Tube

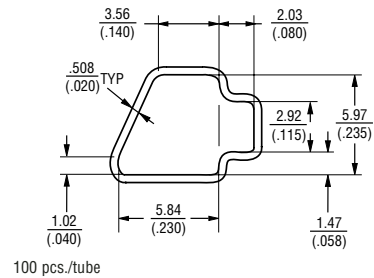

Reflow Soldering Profile

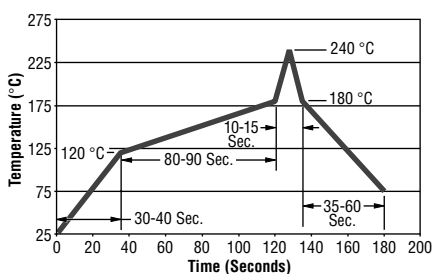

SDHH Series Half Pitch SMD DIP Switch

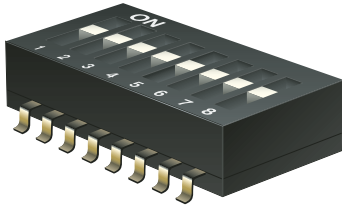

BOURNS®

Features

- Eight and four positions available
- Gold plated contacts offer high reliability
- Low contact resistance
- Just 1.5 mm total height
- Half pitch of 1.27 mm (.050 in.)
- RoHS compliant†

Electrical Characteristics

Electrical Life1,000 operation cycles per switch min.
 Non-Switching Rating100 mA, 50 VDC
 Switching Rating25 mA, 24 VDC
 Contact Resistance.....100 mohms max.
 Insulation Resistance100 Mohms min., DC 100 V min.
 Dielectric Strength...AC 300 V for 1 minute
 Capacitance.....5 pF max. between adjacent closed switch
 CircuitSingle pole single throw

Environmental Characteristics

Mechanical Life.....2,000 operations per switch min.
 Operation Force500 g max.
 Stroke.....0.6 mm
 Operating Temp. Range...-30 °C to +85 °C
 Storage Temperature-40 °C to +85 °C
 Vibration TestMIL-STD-202F, Method 201A
 Frequency10-50-10 Hz/1 minute
 DirectionsX,Y,Z, three mutually perpendicular directions
 Time.....2 hours each direction, high reliability
 Shock TestMIL-STD-202F, Method 213B, Condition A
 Gravity50 G (peak value), 11 msec
 Direction & Times6 sides and 3 times in each direction. High reliability

Physical Characteristics

Cover Materials.....Thermoplastic Nylon, UL 94V-0; black
 Base MaterialsThermoplastic Nylon, UL 94V-0; black
 Actuator Materials.....Thermoplastic Nylon, UL 94V-0; white
 Contact Materials.....Alloy Copper
 Contact Plating3 Micro inches gold over 40 micro inches nickel
 Terminal MaterialsBrass with Gold plating
 Reflow SolderingPeak temperature or reflow oven should be set to 240 °C. max. 2 sec. while applying solder
 PackagingAll poles in the "off" position

Product Dimensions

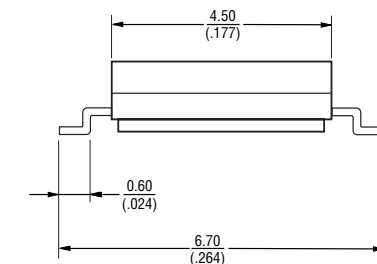
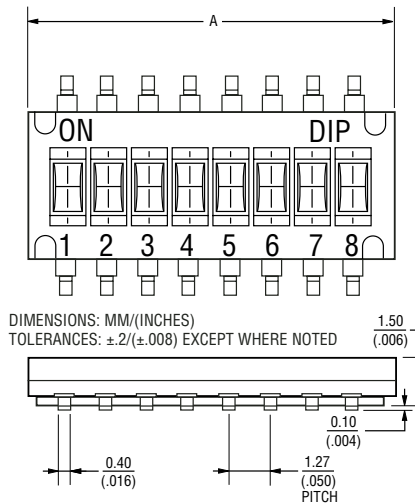

Recommended PCB Layout

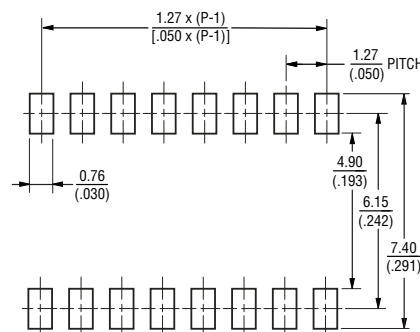

Circuit Diagram

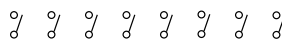

SDHH Series Dimensions

Model No.	Pos.	Dim. A	Dim. B
SDHH-4	4	6.31 (.248)	3.81 (.15)
SDHH-8	8	11.39 (.448)	8.89 (.35)

How To Order

Model _____ SDH H - 8 - T R
 Actuator _____
 H = Recessed
 Number of positions _____
 -4 = 4 positions
 -8 = 8 positions
 Seal _____
 -T = Top tape sealed (standard)
 Packaging _____
 R = Tape and reel

Reflow Soldering Profile

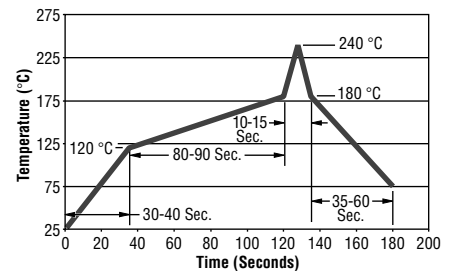

Specifications are subject to change without notice.
 †RoHS Directive 2002/95/EC Jan 27 2003 including Annex.
 Customers should verify actual device performance in their specific applications. REV 09/04

SDHH Series – Packaging Specifications

Switches

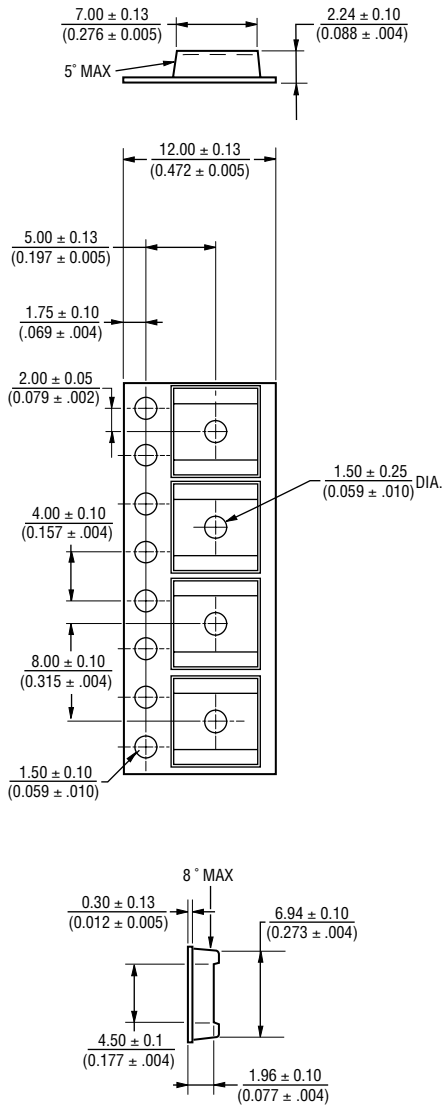

Specifications are subject to change without notice.
 Customers should verify actual device performance in their specific applications.

SDM Series – Surface Mount DIP Switch

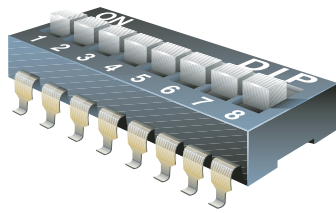

BOURNS®

Features

- Double contacts
- Low contact resistance
- Self-clean on contact area
- Vapor phase solderable, IR-reflow solderable
- Terminal plating by gold gives excellent results when soldering

■ RoHS compliant†

Electrical Characteristics

Electrical Life.....2,000 operations min. per switch, 24 VDC, 25 mA
 Non-Switching Rating100 mA, 50 VDC
 Switching Rating25 mA, 24 VDC
 Contact Resistance (@ current 100 mA)50 milliohms max. at initial
 100 milliohms max. after life test
 Insulation Resistance100 megohms min. at 500 ±15 VDC
 Dielectric Strength500 VDC/minute
 Capacitance5 pF max. between adjacent closed switch
 CircuitSingle pole single throw

Environmental Characteristics

Mechanical Life2,000 operations per switch
 Operation Force1000 gf max.
 Stroke1.0 mm
 Operating Temp. Range...-20 °C to +70 °C
 Storage Temperature-40 °C to +85 °C
 Vibration TestMIL-STD-202F, Method 201A
 Frequency10-55-10 Hz/1 minute
 DirectionsX,Y,Z, three mutually perpendicular directions
 Time2 hours each direction.
 High reliability
 Shock TestMIL-STD-202F, Method 213B, Condition A
 Gravity50 G (peak value), 11 msec
 Direction & Times6 sides and 3 times in each direction.
 High reliability

Physical Characteristics

Base and Cover Materials ..UL94V-0 PPS plus glass fiber reinforced
 ColorBlack
 Actuator Materials.....Nylon plus glass fiber reinforced
 ColorWhite
 Contact MaterialsAlloy copper
 Terminal MaterialsBrass
 Contact Plating Materials3 micro inches gold plating over 40 micro inches nickel
 Terminal Plating MaterialsGold
 Soldering Process.....Vapor phase and IR-reflow soldering can be applied
 Standard PackagingIC tubes/all poles in the "off" position

Specifications are subject to change without notice.
 †RoHS Directive 2002/95/EC Jan 27 2003 including Annex.
 Customers should verify actual device performance in their specific applications. REV 09/04

Product Dimensions

SDM Series

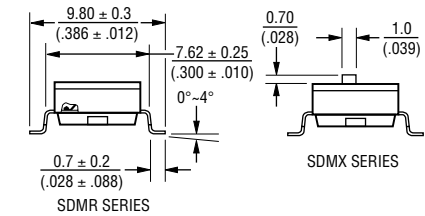
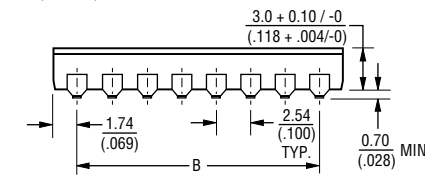
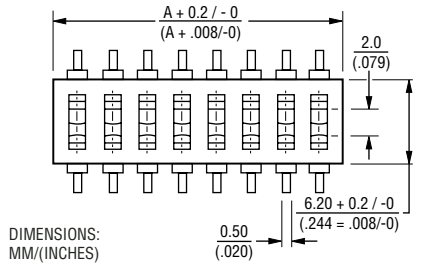

RECOMMENDED PCB LAYOUT

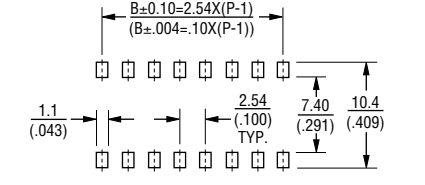

SCHEMATIC (TYP.)
 1,2,3,4,5,6,7,8,9,10,12 POSITIONS AVAILABLE



SDM Series Dimensions

Model No.	Pos.	Dim. A	Dim. B
SDM-12	12	31.42	27.94
SDM-10	10	26.34	22.86
SDM-8	8	21.26	17.78
SDM-6	6	16.18	12.70
SDM-4	4	11.10	7.62
SDM-2	2	6.02	2.54

Packaging Specifications

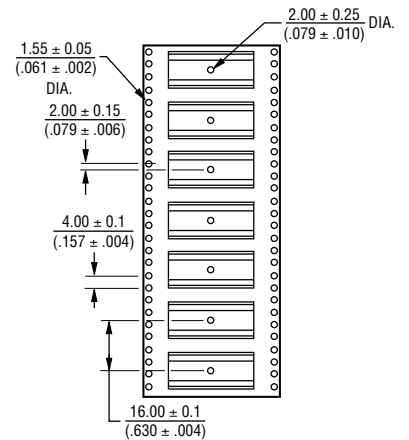

Pole	Tape Size (W)
2, 3	16 mm
4, 5, 6	24 mm
7, 8	32 mm
9, 10, 12	44 mm

How To Order

SDM R - 2 - T R

Model _____
 Actuator
 X = Raised R = Recessed
 Number of Positions
 1 = 1 Position 7 = 7 Positions
 2 = 2 Positions 8 = 8 Positions
 3 = 3 Positions 9 = 9 Positions
 4 = 4 Positions 10 = 10 Positions
 5 = 5 Positions 12 = 12 Positions
 6 = 6 Positions
 Seal
 X = Standard (Not Sealed)
 T = Top Tape Sealed ("R" Actuator only)
 Packaging Option
 (Top Sealed, Recessed Only)
 R = Tape and Reel Packaging (900 pcs./reel)

Reflow Soldering Profile

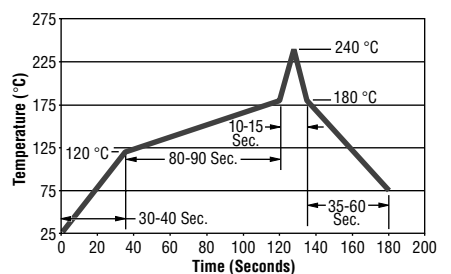

Switches

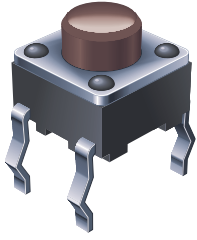

BOURNS®

SDT Series – Tact Switch

Features

- Available sharp click feel with a positive tactile feedback
- Ultra-miniature and lightweight structure suitable for high density mounting
- Economical with high reliability
- Insert molding in the contact with special treatment prevents flux buildup during soldering and permits autodipping
- RoHS compliant†

Electrical Characteristics

Electrical Life
500,000 cycles min. for 260 g
 1,000,000 cycles min. for 100 g, 160g
 Rating.....DC 12 V 50 mA
 Contact Resistance.....100 milliohms max.
 Insulation Resistance
100 megohms, DC 500 V min.
 Dielectric Strength...250 V AC for 1 minute
 Contact Arrangement.....1 pole 1 position

Environmental Characteristics

Operation Force.....260 g ±50 g,
 160 g ±50 g, 100 g ±50 g
 Stop StrengthPlace the switch such
 that vertical, a static load of 3 kg shall
 be applied in the direction of actuator
 operation for a period of 15 sec.
 Stroke
 6mm type0.25 +0.2/-0.1 mm
 12mm type.....0.35 ±0.1 mm
 Temperature Range.....-20 °C to +70 °C
 Vibration Test.....Mil-STD-202F,
 Method 201A
 Frequency10-55-10 Hz/1 minute
 DirectionsX,Y,Z, three mutually
 perpendicular directions
 Time.....2 hours each direction.
 High reliability
 Shock TestMIL-STD-202F,
 Method 213B, Condition A
 Gravity50 G (peak value), 11 msec
 Direction & Times6 sides and
 3 times in each direction.
 High reliability

Physical Characteristics

Cover Materials.....Steel
 Base Materials.....UL94V-0 PBT plus glass
 fiber reinforced
 Cover/Base Color.....Black
 Actuator MaterialsDulacon POM
 plus glass fiber reinforced
 Actuator Color.....Black, brown, red
 Contact Disc Materials....Phosphor bronze
 with silver cladding
 Terminal Materials
Brass with silver cladding
 Wave Soldering Process
Recommended solder temperature
 at 260 °C (500 °F) max., 5 seconds
 Hand Soldering Process
Use a soldering iron of 30 watts
 or less, controlled at 320 °C (608 °F)
 for approximately 2 seconds while
 applying solder
 Packaging1,000 pieces per bag

Specifications are subject to change without notice.
 †RoHS Directive 2002/95/EC Jan 27 2003 including Annex.
 Customers should verify actual device performance in
 their specific applications. REV 09/04

Product Dimensions

SDTX-610/620/630/650/660

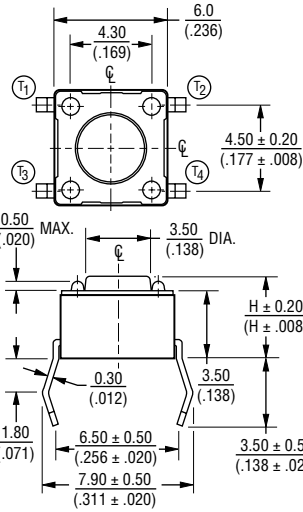

SDTX-644/648

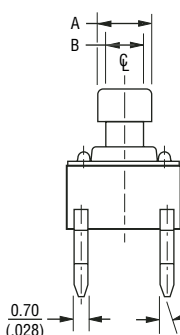

SDTX-644	
Dim.	mm/(in)
A	$\frac{2.4 \pm 1/-0}{(.094 \pm .004/-0)}$
B	$\frac{1.6 \pm 1/-0}{(.063 \pm .004/-0)}$

SDTX-648	
Dim.	mm/(in)
A	$\frac{2.8 \pm 1/-0}{(.110 \pm .004/-0)}$
B	$\frac{2.0 \pm 1/-0}{(.079 \pm .004/-0)}$

RECOMMENDED PCB LAYOUT

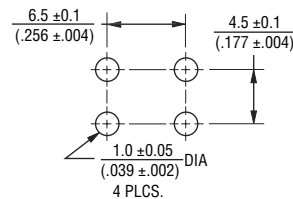

CIRCUIT DIAGRAM

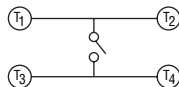

DIMENSIONS: MM/(INCHES)

SDTG-610/620/630/650/660

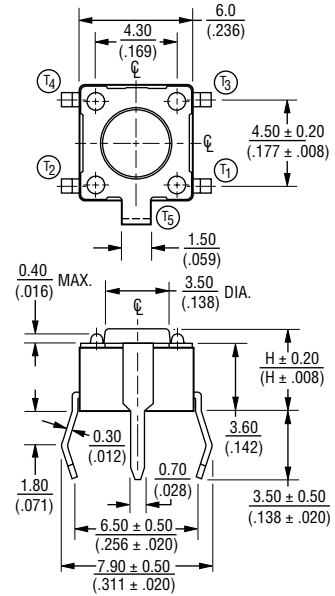

SDTG-644/648

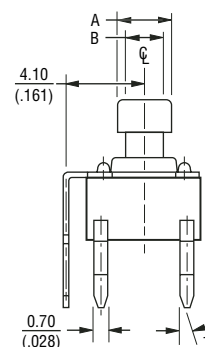

SDTG-644	
Dim.	mm/(in)
A	$\frac{2.4 \pm 1/-0}{(.094 \pm .004/-0)}$
B	$\frac{1.6 \pm 1/-0}{(.063 \pm .004/-0)}$

SDTG-648	
Dim.	mm/(in)
A	$\frac{2.8 \pm 1/-0}{(.110 \pm .004/-0)}$
B	$\frac{2.0 \pm 1/-0}{(.079 \pm .004/-0)}$

CIRCUIT DIAGRAM

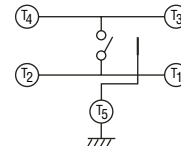

RECOMMENDED PCB LAYOUT

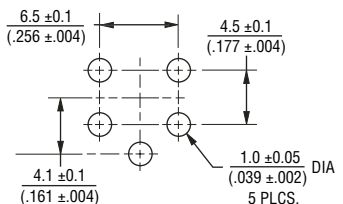

SDT Series – Product Dimensions

SDTA-610/620/630/650/660

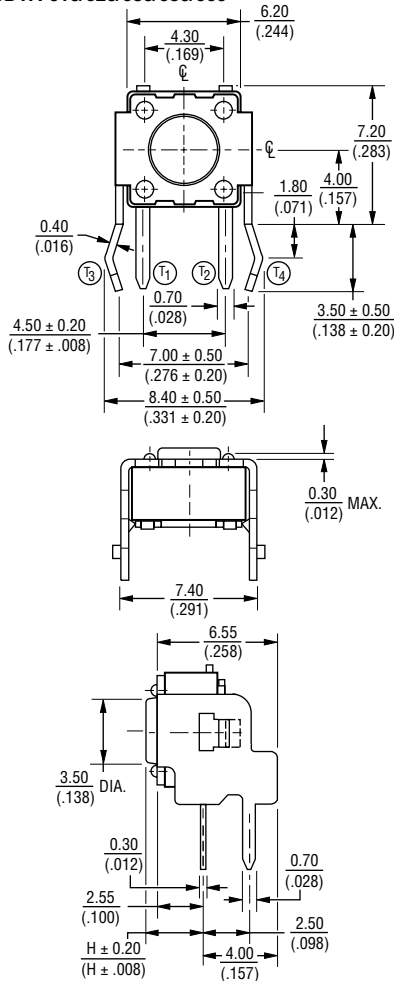

RECOMMENDED PCB LAYOUT

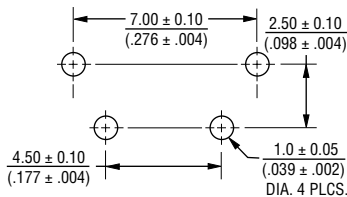

CIRCUIT DIAGRAM

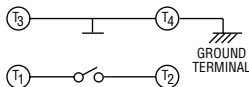

SDTA-644/648

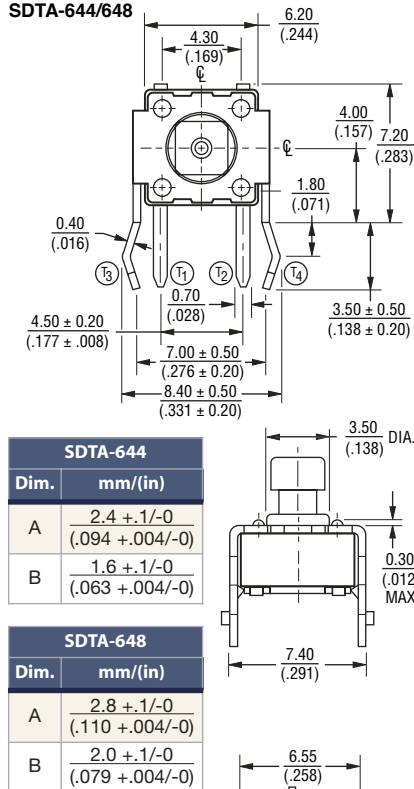

SDTA-644	
Dim.	mm/(in)
A	$\frac{2.4 + 1/-0}{(.094 + .004/-0)}$
B	$\frac{1.6 + 1/-0}{(.063 + .004/-0)}$

SDTA-648	
Dim.	mm/(in)
A	$\frac{2.8 + 1/-0}{(.110 + .004/-0)}$
B	$\frac{2.0 + 1/-0}{(.079 + .004/-0)}$

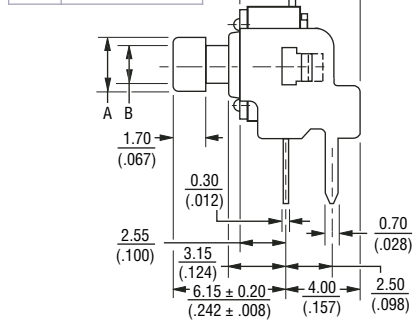

RECOMMENDED PCB LAYOUT

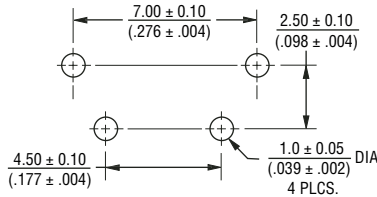

CIRCUIT DIAGRAM

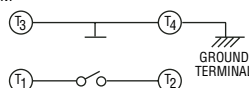

SDTX-210

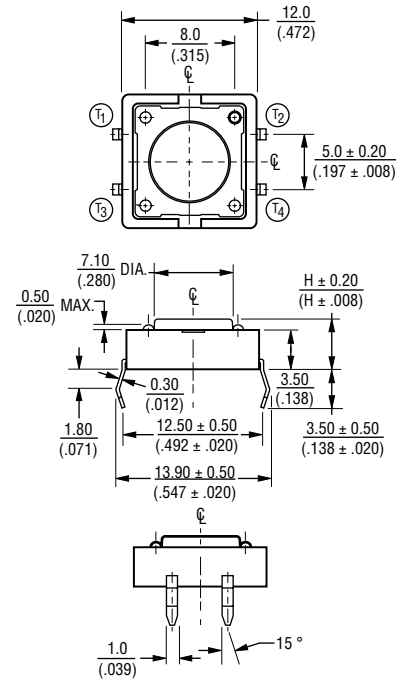

RECOMMENDED PCB LAYOUT

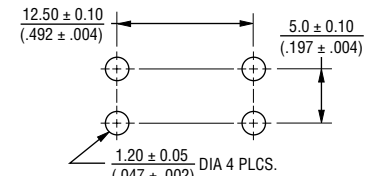

CIRCUIT DIAGRAM

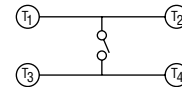

DIMENSIONS: MM/(INCHES)

Specifications are subject to change without notice. Customers should verify actual device performance in their specific applications.

SDT Series – Product Dimensions, Packaging Specifications and Ordering Information

Switches

Product Dimensions

SDTX-244

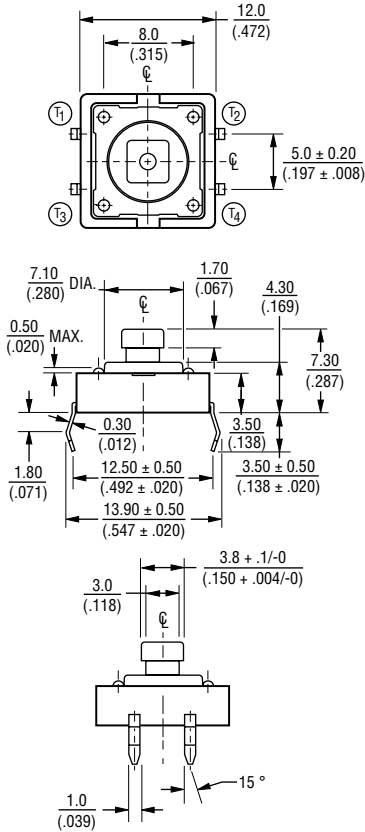

RECOMMENDED PCB LAYOUT

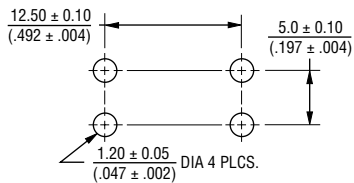

CIRCUIT DIAGRAM

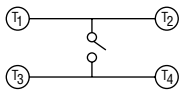

DIMENSIONS: MM/(INCHES)

Packaging Specifications

SDTX-610/620/630/644/648/650 Ammo Pack

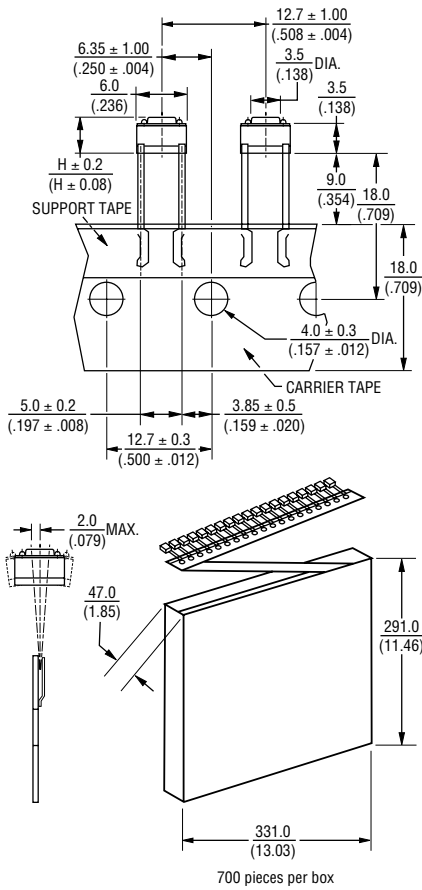

RECOMMENDED PCB LAYOUT

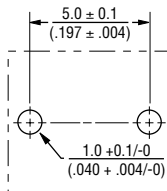

CIRCUIT DIAGRAM

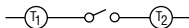

How To Order

SDT G - 6 10 - K AP

- Model _____
- Product Series _____
- X = Standard
 - G = Ground Terminal
 - A = Right Angle Type
- Body Size _____
- 6 = 6 mm
 - 2 = 12 mm*
- Distance from First Pin to Top of Head (Right Angle Type) _____
- 10 = 3.15 mm
 - 20 = 3.85 mm
 - 30 = 5.85 mm
 - 44 = 6.15 mm (square head)
 - 48 = 6.15 mm (square head)
 - 50 = 8.35 mm
 - 60 = 11.85 mm
- Height (Standard Type) _____
- 10 = 4.3 mm
 - 20 = 5.0 mm
 - 30 = 7.0 mm
 - 44 = 7.3 x 2.4 mm (square head)
 - 48 = 7.3 x 2.8 mm (square head)
 - 50 = 9.5 mm
 - 60 = 13 mm
- Actuating Force _____
- K = 100 g (black head – 6 mm only)
 - N = 160 g (brown head)
 - R = 260 g (red head)
- Packaging Option (SDTX only) _____
- AP = Ammo Pak
- *Options available:
SDTX-210
SDTX-244

Reflow Soldering Profile

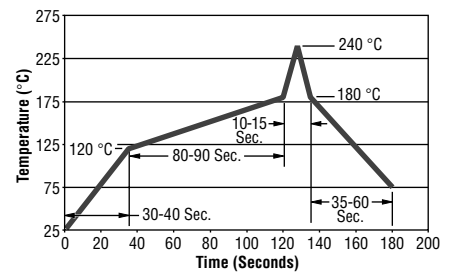

Specifications are subject to change without notice. Customers should verify actual device performance in their specific applications.

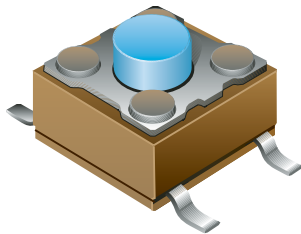

BOURNS®

SDTM Series – SMD Tact Switch

Features

- Available sharp click feel with a positive tactile feedback
- Ultra-miniature and lightweight structure suitable for high density mounting
- Very economical with high reliability
- Insert molding in the contact with special treatment prevents flux buildup during soldering and permits autodipping
- RoHS compliant†

Electrical Characteristics

Electrical Life

.....50,000 cycles min. for 260 g
 500,000 cycles min. for 100 g, 160 g
 RatingDC 12 V, 50 mA
 Contact Resistance.....100 mohms max.
 Insulation Resistance.....100 Mohms min.,
 DC 500 V min.
 Dielectric Strength...AC 250 V for 1 minute
 Contact Arrangement.....1 pole 1 position

Environmental Characteristics

Operation Force100 g, 160 g, 260 g
 Tolerance..... ±50 g
 Stop Strength.....Place the switch vertical,
 a static load of 3 kg shall be
 applied in the direction of actuator
 operation for a period of 15 seconds
 Stroke.....0.25 mm (+0.2 mm, -0.1 mm)
 Temperature Range.....-25 °C to +70 °C
 Vibration TestMIL-STD-202F,
 Method 201A
 Frequency10-50-10 Hz/1 minute
 Directions.....X,Y,Z 3 mutually
 perpendicular directions
 Time.....2 hours each direction,
 high reliability
 Shock TestMIL-STD-202F,
 Method 213A, Condition A
 Gravity.....50 g (peak value), 11 msec.
 Directions/Time.....6 sides and 3 times
 in each direction

Physical Characteristics

Cover Materials.....Steel, tin plated
 Base MaterialsThermoplastic Nylon
 FG 101, UL94V-0
 Actuator MaterialsThermoplastic
 Nylon UL94V-0
 ColorBlack, brown, red
 Contact Disc. MaterialsPhosphor
 bronze with silver cladding
 Terminal Materials.....Brass with silver
 cladding

Product Dimensions

SDTM-610/620/630/650/660

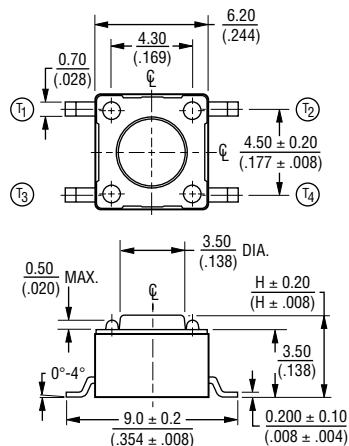

SDTM-644/648

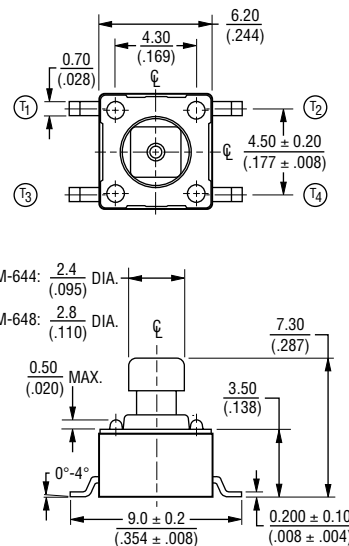

RECOMMENDED PCB LAYOUT

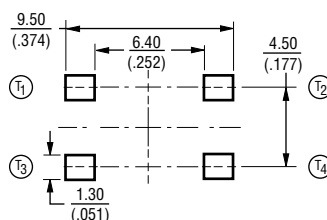

DIMENSIONS: MM/(INCHES)
 TOLERANCES: ±.2/(±.008) EXCEPT WHERE NOTED

How To Order

SDT M - 6 10 - K TR

Model _____
 Product Code _____
 M = SMD
 Body Size _____
 6 = 6 mm
 Height _____
 10 = 4.3 mm
 20 = 5.0 mm
 30 = 7.0 mm
 44 = 7.3 mm (square head)
 48 = 7.3 mm (square head)
 50 = 9.5 mm
 60 = 13 mm
 Actuating Force _____
 K = 100 g (black)
 N = 160 g (brown)
 R = 260 g (red)
 Packaging Option _____
 TR = Embossed Tape*
 610 = 1000 pcs.
 620 = 900 pcs.
 630, 644, 648 = 500 pcs.
 650 = 380 pcs.
 — = Tube
 All models = 77 pcs.
 *Not applicable to Model 660.

CIRCUIT DIAGRAM

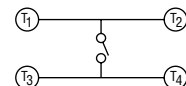

Specifications are subject to change without notice.
 †RoHS Directive 2002/95/EC Jan 27 2003 including Annex.
 Customers should verify actual device performance in
 their specific applications. REV 09/04

SDTM Series – Packaging Specifications

Packaging Specifications

SDTM-610/620/630/644/648/650(TR)

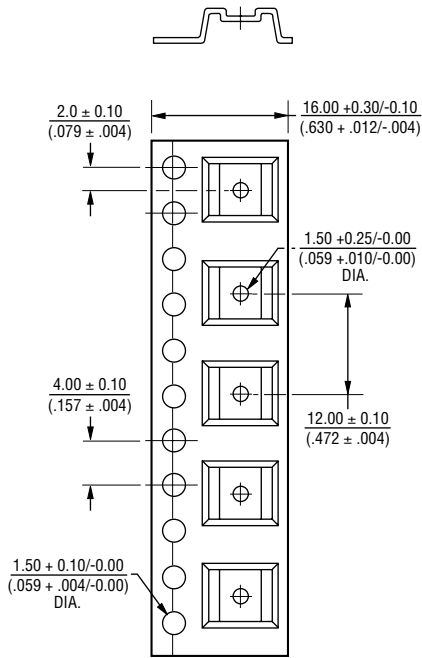

DIMENSIONS: MM/(INCHES)
TOLERANCES: ±.2/(±.008) EXCEPT WHERE NOTED

SDTM-610/620/630/644/648/650/660(TUBE)

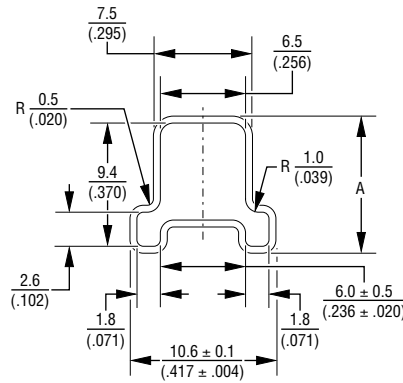

Model Number	Dimension A
SDTM-630, 644, 648	10.40 (.409)
SDTM-650, 660	15.9 ± 0.1 (.626 ± .004)
SDTM-610, 620	5.5 (.217)

Reflow Soldering Profile

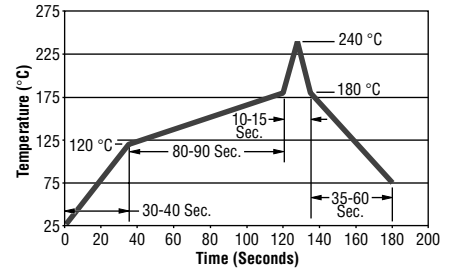

Specifications are subject to change without notice.
Customers should verify actual device performance in their specific applications.



BOURNS®

SND Series – DIP Switch (Machine Insertable Type)

Features

- Double contacts offer high reliability
- Low contact resistance
- Self-clean on contact area
- Splay terminals allow for automatic insertion by IC insertion machine
- Straight terminals are available for manual insertion
- RoHS compliant*

Electrical Characteristics

Electrical Life.....2,000 operations min. per switch, 24 VDC, 25 mA
 Non-Switching Rating100 mA, 50 VDC
 Switching Rating25 mA, 24 VDC
 Contact Resistance (@ current 100 mA)50 milliohms max. at initial
 100 milliohms max. after life test
 Insulation Resistance100 megohms min. at 500 ±15 VDC
 Dielectric Strength500 VDC/minute
 Capacitance5 pf max. between adjacent closed switch
 CircuitSingle pole single throw

Environmental Characteristics

Mechanical Life2,000 operations per switch
 Operation Force1,000 g max.
 Stroke1.0 mm
 Operating Temp. Range...-20 °C to +70 °C
 Storage Temperature-40 °C to +85 °C
 Vibration TestMIL-STD-202F, Method 201A
 Frequency10-55-10 Hz/minute
 DirectionsX,Y,Z, three mutually perpendicular directions
 Time.....2 hours each direction.
 High reliability
 Shock TestMIL-STD-202F, Method 213B, Condition A
 Gravity50 G (peak value), 11 msec
 Direction & Times6 sides and 3 times in each direction.
 High reliability

How To Order

SND X - 1 S - X

Model _____
 Actuator _____
 X = Raised Actuator
 R = Recessed Actuator
 Number of Positions _____
 -1 = 1 Position -7 = 7 Positions
 -2 = 2 Positions -8 = 8 Positions
 -3 = 3 Positions -9 = 9 Positions
 -4 = 4 Positions -10 = 10 Positions
 -5 = 5 Positions -12 = 12 Positions
 -6 = 6 Positions
 Terminal Type _____
 S = Splay (Machine Insertion Type)
 H = Straight (Manual Insertion Type)
 Seal _____
 -X = Standard (Not Sealed)
 -T = Top Tape Sealed
 ("R" actuator only, excluding 1 position)

Physical Characteristics

Base and Cover MaterialsUL 94V-0 high-temperature thermoplastic PPS
 ColorBlack
 Actuator MaterialsUL 94V-0 nylon thermoplastic
 ColorWhite
 Contact MaterialsAlloy copper
 Terminal MaterialsBrass
 Contact Plating Materials3 micro inches gold plating over 40 micro inches nickel
 Terminal Plating MaterialsGold
 Wave Soldering Process*Recommended solder temp. at 260 °C (500 °F) max., 5 sec.
 Hand Soldering Process*Use a soldering iron of 30 watts or less, controlled at 320 °C (608 °F) for approx. 2 sec. while applying solder
 Standard PackagingIC tubes/all poles in the "off" position

SND Series Dimensions

Model No.	Pos.	Dim. A	Dim. B
SND-12	12	31.42 (1.237)	26.94 (1.100)
SND-10	10	26.34 (1.037)	22.86 (.900)
SND-9	9	23.80 (.937)	20.32 (.800)
SND-8	8	21.26 (.837)	17.78 (.700)
SND-6	6	16.18 (.637)	12.70 (.500)
SND-5	5	13.64 (.537)	10.16 (.400)
SND-4	4	11.10 (.437)	7.62 (.300)
SND-3	3	8.56 (.337)	5.08 (.200)
SND-2	2	6.02 (.237)	2.54 (.100)
SND-1	1	3.48 (.137)	—

Product Dimensions

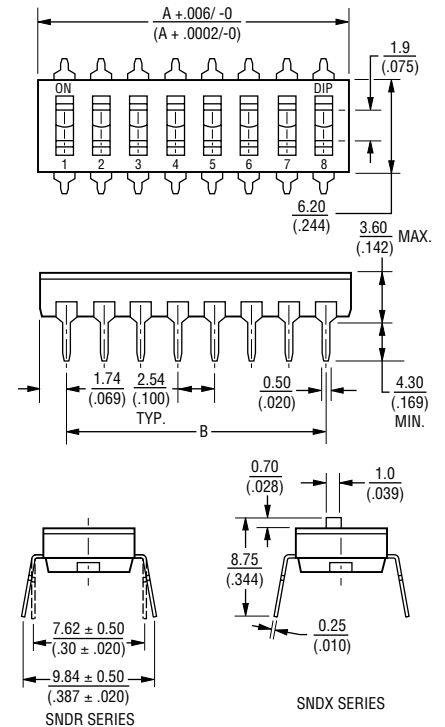

RECOMMENDED PCB LAYOUT

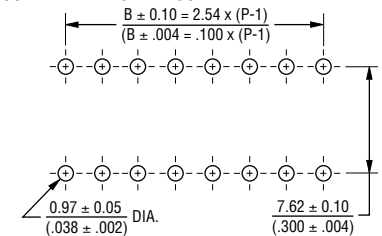

SCHEMATIC (TYP.) 1-12 POSITIONS AVAILABLE



DIMENSIONS: MM/(INCHES)

Specifications are subject to change without notice.
 *RoHS Directive 2002/95/EC Jan 27 2003 including Annex.
 Customers should verify actual device performance in their specific applications. REV 09/04

SND Series – Packaging Specifications

Product Dimensions

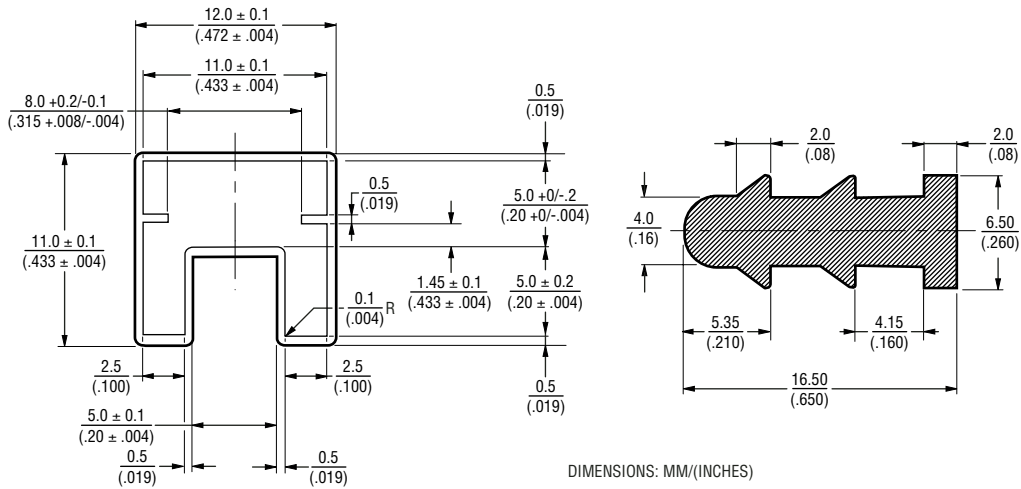

Reflow Soldering Profile

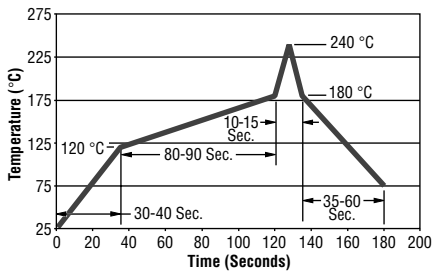

Specifications are subject to change without notice.
Customers should verify actual device performance in their specific applications.

ST(H,M,J)W Series – Packaging Specifications and Ordering Information

Packaging Specifications

STMW-660/667//680/690(TR)
STJW-660/667/680/690(TR)

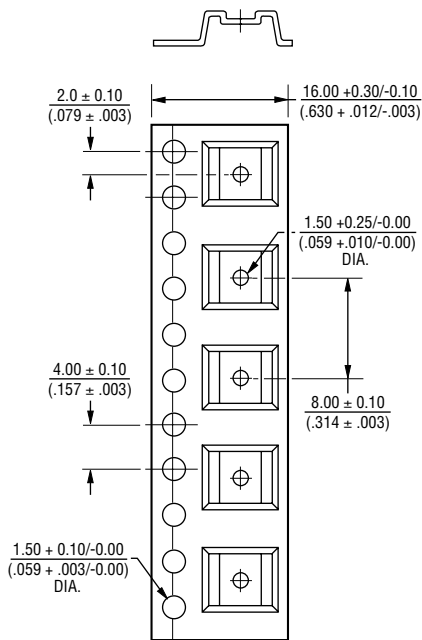

How To Order

STM W - 6 60 - N TR

Model
 STM = SMD "G" Style
 STH = Through-hole
 STJ = SMD J-Hook

Product Type
 W = Washable

Size
 -6 = 6 mm

Height
 60 = 3.1/(0.12) (N)
 67 = 5.2/(0.20) (N)
 80 = 2.30/(0.09) (S)
 90 = 3.7/(0.15) (N, R)

Actuating Force
 -S = 160 g (Silver)
 -N = 160 g (Brown)
 -R = 260 g (Red)
 -V = 300 g (Clear)

Packaging Option
 (Type M, J only)
 TR = Embossed tape
 660, 667, 680 = 2000 pcs.
 690 = 1900 pcs.

Reflow Soldering Profile

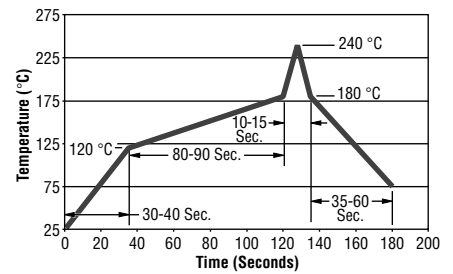

Specifications are subject to change without notice.
 Customers should verify actual device performance in
 their specific applications.



STJN-4 – SMD Super-Thin Tact Switch

Features

- Super-thin 4.5 mm square SMD
- Two different operating forces
- 0.55 mm height without knob
- Compatible with surface mount reflow soldering processes

■ RoHS compliant*

BOURNS®

Electrical Characteristics

Max. Power Rating.....12 VDC max., 20 mA
 Contact Resistance100 milliohms max.
 Insulation Resistance
50 megohms min., 100 VDC
 Dielectric Strength...AC 100 V for 1 minute
 Bounce
 On3 ms max.
 Off10 ms max.
 CircuitN.O. SPST

Mechanical Characteristics

Mechanical Life.....50,000 cycles min.
 Actuation Force
160 gf ±50 gf (1.6 N ±0.5 N)
240 gf ±60 gf (2.4 N ± 0.6 N)
 Stroke0.2 mm ±0.1 mm

General Characteristics

Switch Type(N.O.) SPST
 Operating Temperature Range
-20 °C to +70 °C
 Storage Temperature Range
-40 °C to +85 °C

Product Dimensions

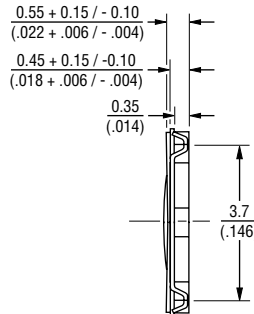
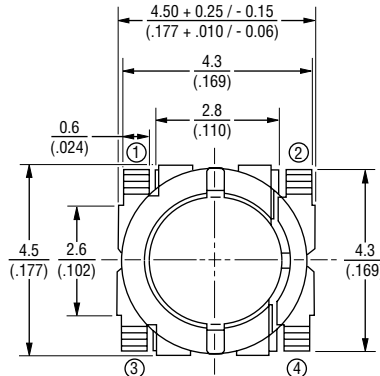

DIMENSIONS:
MM/(INCHES)



Recommended PCB Layout

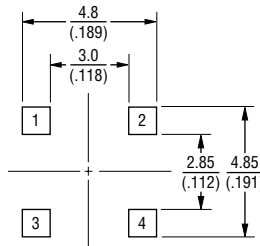

Circuit Diagram

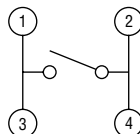

How To Order

STJ N - 4 05 - N TR

Model _____
 Thin SMD Tact Switch
 Product Code _____
 N = Non-washable
 Size _____
 -4 = 4.5 mm
 Height _____
 05 = 0.55 mm (without knob)
 Actuating Force _____
 -N = 160 gf (1.6 N)
 -P = 240 gf (2.4 N)
 Packaging Option _____
 TR = Embossed tape
 10,000 pcs./reel

Reflow Soldering Profile

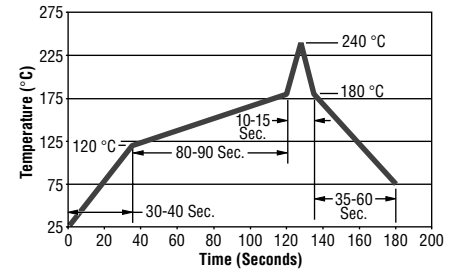

Switches

Specifications are subject to change without notice.
 *RoHS Directive 2002/95/EC Jan 27 2003 including Annex.
 Customers should verify actual device performance in
 their specific applications. REV 09/04

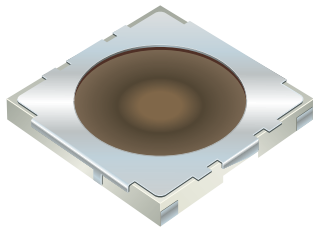

BOURNS®

STJN-5 – SMD Thin Tact Switch

Features

- Thin 5 mm square SMD
- Three different operating forces
- 0.8 mm height without knob (1.5 mm with knob)
- Compatible with surface mount reflow soldering processes
- RoHS compliant†

Electrical Characteristics

Max. Power Rating.....12 VDC max., 50 mA
 Contact Resistance100 milliohms max.
 Insulation Resistance
100 megohms min., 100 VDC
 Dielectric Strength...AC 250 V for 1 minute
 Bounce
 On3 ms max.
 Off10 ms max.
 CircuitN.O. SPST

Mechanical Characteristics

Mechanical Life
 100 gf + 160 gf.....500,000 cycles min.
 260 gf200,000 cycles min.
 Actuation Force
100 gf ±50 gf (1.0 N ±0.5 N)
160 gf ±50 gf (1.6 N ±0.5 N)
260 gf ±60 gf (2.6 N ± 0.6 N)
 Stroke.....0.25 mm +0.10/-0.20

General Characteristics

Switch Type(N.O.) SPST
 Operating Temperature Range
-20 °C to +70 °C
 Storage Temperature Range
-40 °C to +85 °C

How To Order

STJ N - 5 08 - N TR

Model _____
 Thin SMD Tact Switch

Product Code _____
 N = Non-washable

Size _____
 -5 = 5 mm

Height _____
 08 = 0.8 mm (without knob)
 15 = 1.5 mm (with knob)

Actuating Force _____
 -K = 100 gf (1.0 N)
 -N = 160 gf (1.6 N)
 -R = 260 gf (2.6 N)

Packaging Option _____
 TR = Embossed tape
 5,000 pcs./reel

Reflow Soldering Profile

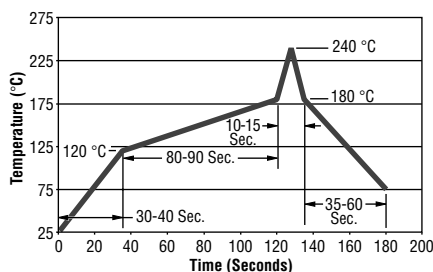

Product Dimensions

STJN-508

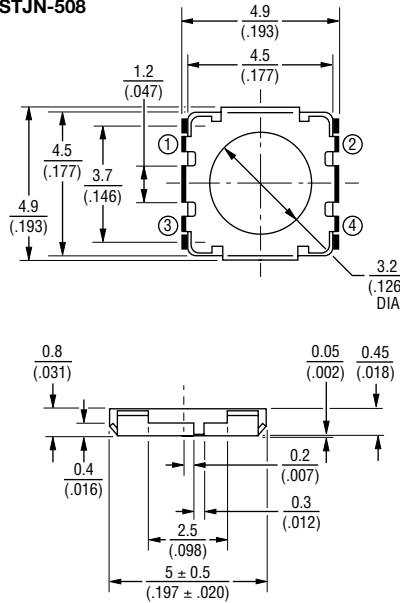

STJN-515

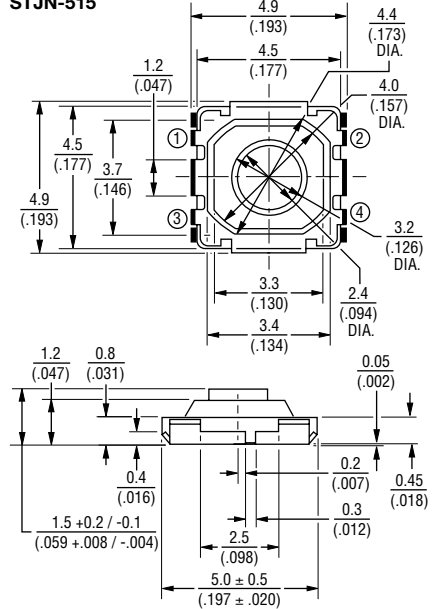

Recommended PCB Layout

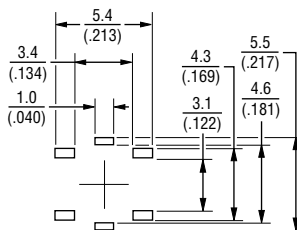

Recommended PCB Layout

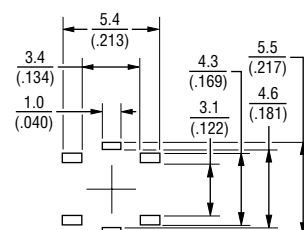

Circuit Diagram

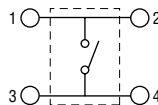

DIMENSIONS: MM/(INCHES)
 TOLERANCES: ±.38(±.015) EXCEPT WHERE NOTED

Circuit Diagram

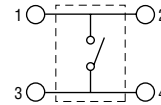

Specifications are subject to change without notice.
 †RoHS Directive 2002/95/EC Jan 27 2003 including Annex.
 Customers should verify actual device performance in
 their specific applications. REV 09/04

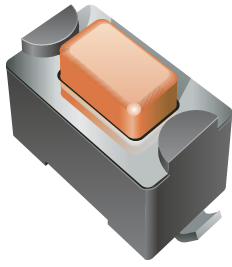

BOURNS®

STSM – Ultraminiature Tactile Switch

Features

- Available sharp click feel with a positive tactile feedback
- Ultraminiature and lightweight structure suitable for high density mounting
- Economical
- Reliable
- RoHS compliant*

Electrical Characteristics

Electrical Life50,000 Cycles for 160 gf, 320 gf
 Rating50 mA, 12 VDC
 Contact Resistance100 mΩ max.
 Insulation Resistance100 MΩ min. @ 500 VDC
 Dielectric Strength.....250 VAC/1 minute
 Contact Arrangement.....SPST

Environmental Characteristics

Operation Temperature Range-25 °C to +70 °C
 Storage Temperature Range-30 °C to +80 °C
 Vibration TestMIL-STD-202F Method 201A
 Frequency.....10-55-10Hz/1 minute
 DirectionsX,Y,Z, three mutually perpendicular directions
 Time.....2 hours each direction
 Shock TestMIL-STD-202F Method 213B Condition A
 Gravity50 G (peak value), 11 msec
 Direction and Times...6 sides and 3 times in each direction

Physical Characteristics

Cover MaterialsStainless Steel
 Base Materials.....UL 94V-0 Nylon or PPA High-Temperature Thermoplastic
 ActuatorUL 94V-0 Nylon High-Temperature Thermoplastic
 Contact DiscStainless steel with silver cladding
 Terminals.....Brass with silver cladding

Product Dimensions

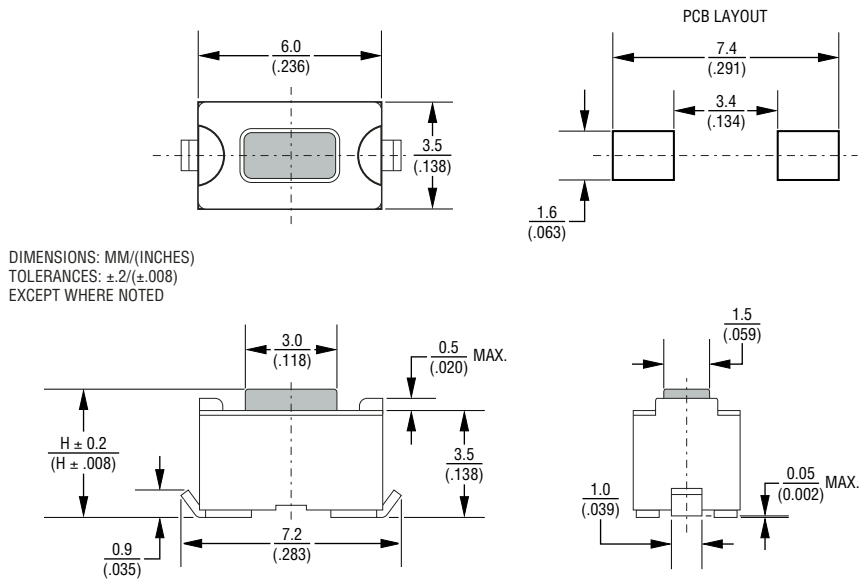

How To Order

STSM - 31 - S TR

Model _____
 Style _____
 M = Surface mount
 Product Size _____
 -3 = 3.5 mm wide x 6 mm long
 Height _____
 1 = 4.3 mm
 2 = 5.0 mm
 Color of Stem for Operating Force _____
 -N = Brown, 160 g
 -S = Salmon, 320 g
 Packaging Option _____
 — = Standard Packaging
 135 pcs./tube
 TR = Tape & Reel Packaging
 31 – 1800 pcs./reel
 32 – 1600 pcs./reel

Circuit Diagram

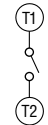

Reflow Soldering Profile

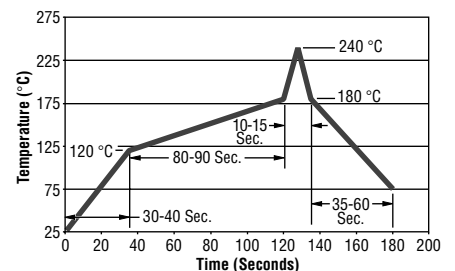

Specifications are subject to change without notice.
 *RoHS Directive 2002/95/EC Jan 27 2003 including Annex.
 Customers should verify actual device performance in their specific applications. REV 09/04

Technical Guides

How to Use This Section

This Applications/Processing Guide is intended to provide you with points to consider for designing circuits, selecting trimmers and arranging board layouts, to achieve maximum performance and long life for your circuits and systems. We have also included information on steps your manufacturing engineers can take to preserve circuit reliability.

For example, are you aware that the trimmers and other mechanical components on your boards may face a more extreme environment during boardwashing on your own production line, than they ever will in use? For those trimmers that may need to be reset, are you remembering to select and mount the trimmers to provide easy accessibility?

In this section, you'll find dozens of pointers, reminders and useful facts that will help you be more knowledgeable and successful in using trimmers.

Trimmer Basics

In its most common form, a trimmer is simply a device containing a resistive element, and a wiper, or adjustable tap, contacting the element. The wiper can be mechanically moved to vary the amount of voltage or resistance in the circuit. The resistive element is usually laid out in linear or a circular configuration.

The Resistive Element

Trimmers for commercial applications typically have a resistive element made of carbon or cermet (a combination of CERamic and METal), or of resistance wire wound on an insulated copper mandrel.

The main advantages of wirewound trimmers are their low temperature coefficient, higher power dissipation, lower noise, tighter resistance tolerance, and, when used as a variable resistor, the excellent current-carrying capacity through the wiper due to the lower contact resistance. Also, their long-term resistance stability with time and temperature is slightly better than cermet.

Cermet trimmers provide a wider resistance range (10 ohms to 5 megohms, versus a maximum of 50K ohms for wirewound). Also, the wiper output can be set closer to the desired value since the resistive element presents a continuous contact surface for the wiper, as opposed to the discrete turns (resolution) of the wirewound. Other advantages with cermet are the lower reactance in high-frequency applications, the smaller sizes available, and the generally lower price than wirewound types.

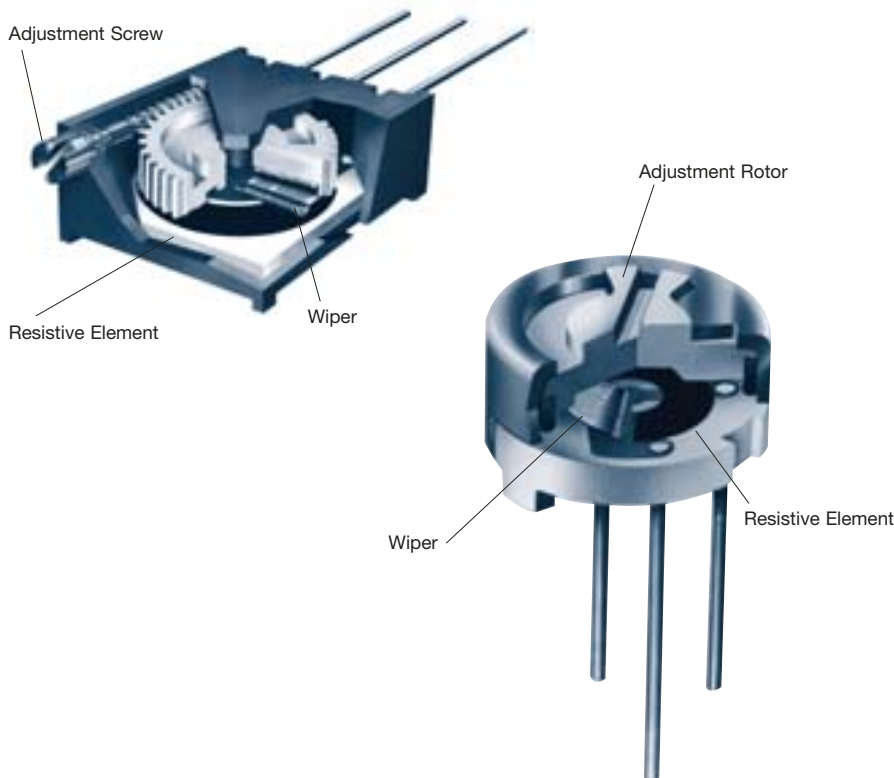
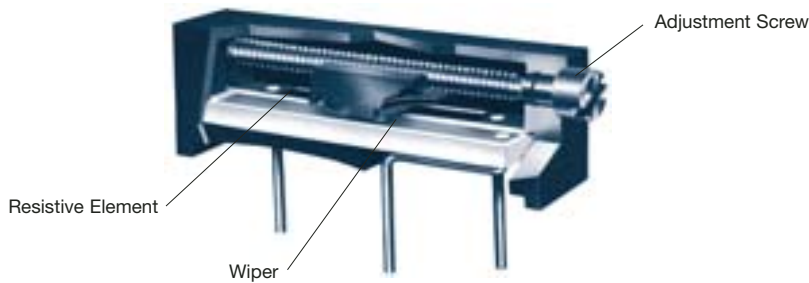

Applications/Processing Guide – Standard and Lead Free

Trimming Potentiometers and Definitions

The following terms and definitions have been edited from the Industrial Standard published by the Variable Electronics Components Institute. It is intended to encourage standardization in communication and understanding between the manufacturer and user. The complete standard, including detailed test procedures, is available upon request.

General Terms

TRIMMING POTENTIOMETER: An electrical mechanical device with three terminals. Two terminals are connected to the ends of a resistive element and one terminal is connected to a movable conductive contact which slides over the element, thus allowing the input voltage to be divided as a function of the mechanical input. It can function as either a voltage divider or rheostat.

WIREWOUND TRIMMING POTENTIOMETER: A trimming potentiometer characterized by a resistance element made up of turns of wire on which the wiper contacts only a small portion of each turn.

NON-WIREWOUND TRIMMING POTENTIOMETER: A trimming potentiometer characterized by the continuous nature of the surface area of the resistance element to be contacted. Contact is maintained over a continuous, unbroken path. The resistance is achieved by using material compositions other than wire such as carbon, conductive plastics, metal film and cermet.

RESISTANCE ELEMENT: A continuous, unbroken length of resistive material without joints, bonds or welds except at the junction of the element and the electrical terminals connected to each end of the element, or at an intermediate point such as a center tap.

ADJUSTMENT SHAFT: The mechanical input member of a trimming potentiometer which when actuated causes the wiper to traverse the resistance element resulting in a change in output voltage or resistance.

SINGLE-TURN ADJUSTMENT: Requires 360 ° or less mechanical input to cause the wiper to traverse the total resistance element.

MULTITURN ADJUSTMENT: Requires more than 360 ° mechanical adjustment to cause the wiper to traverse the total resistance element.

TERMINAL: An external member that provides electrical access to the resistance element and wiper.

LEADWIRE TYPE TERMINAL: Flexible insulated conductor.

PRINTED CIRCUIT TERMINAL: Rigid uninsulated electrical conductor, suitable for printed circuit board plug-in.

SOLDER LUG TERMINAL: Rigid uninsulated electrical conductor, suitable for external lead attachment.

WIPER: The wiper is the member in contact with the resistive element that allows the output to be varied when the adjustment shaft is rotated.

STOP-CLUTCH: A device which allows the wiper to idle at the ends of the resistive element without damage as the adjustment shaft continues to be actuated in the same direction.

STOP – SOLID: A positive limit to mechanical and/or electrical adjustment.

STACKING: The mounting of one trimming potentiometer adjacent to or on top of another utilizing the same mounting hardware.

THEORETICAL RESOLUTION: (Wirewound only) The theoretical measurement of sensitivity to which the output ratio may be adjusted; the reciprocal of the number of turns of wire in resistance winding expressed as a percentage.

N = Total number of resistance wire turns.

$$\frac{1}{N} \times 100 = \text{Theoretical resolution percent.}$$

Input and Output Terms

TOTAL APPLIED VOLTAGE: The total voltage applied between the designated input terminals.

OUTPUT VOLTAGE: The voltage between the wiper terminal and the designated reference point. Unless otherwise specified, the designated reference point is the CCW terminal.

OUTPUT RATIO: The ratio of the output voltage to the designated input reference voltage. Unless otherwise specified, the reference voltage is the total applied voltage.

LOAD RESISTANCE: An external resistance as seen by the Output Voltage (connected between the wiper terminal and the designated reference point.)

Adjustment Terms

DIRECTION OF TRAVEL: Clockwise (CW) or counterclockwise (CCW) rotation when viewing the adjustment end of the potentiometer.

MECHANICAL TRAVEL — SOLID STOPS: The total travel of

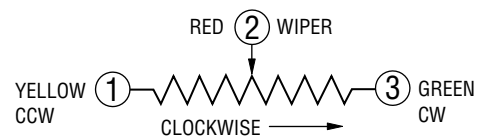

Applications/Processing Guide – Standard and Lead Free

the adjustment shaft between integral stops. Continuity must be maintained throughout the travel.

MECHANICAL TRAVEL — CLUTCHING ACTION: The total travel of the adjustment shaft between the points where clutch actuation begins. Continuity must be maintained throughout the travel and during clutch actuation.

MECHANICAL TRAVEL — CONTINUOUS ROTATION: The total travel of the adjustment shaft when the wiper movement is unrestricted at either end of the resistive element as the adjustment shaft continues to be actuated.

ADJUSTMENT TRAVEL (ELECTRICAL): The total travel of the adjustment shaft between minimum and maximum output voltages.

CONTINUITY TRAVEL: The total travel of the shaft over which electrical continuity is maintained between the wiper and the resistance element.

Electrical and Operational Characteristics

TOTAL RESISTANCE: The DC resistance between the input terminals with the wiper positioned to either end stop, or in dead band for continuous rotation potentiometers.

TEST VOLTAGE

Total Resistance, Nominal (ohms)	Maximum Test Voltage (Volts DC)	
	Non-Wirewound	Wirewound
.1 to 1.0	0.1	0.1
1.0 to 50	0.3	0.3
50 to 100	2.0	2.0
100 to 1000	3.0	3.0
1K to 100K	10	10
Over 0.1 megohm	50	—

NOTE: The test voltages should never exceed the equivalent of 10% rated power. The minimum voltage to be used is 10 MV.

ABSOLUTE MINIMUM RESISTANCE: The resistance measured between the wiper terminal and each end terminal with the wiper positioned to give a minimum value.

END RESISTANCE: The resistance measured between the wiper terminal and an end terminal when the wiper is positioned at the corresponding end of mechanical travel. Absolute minimum resistance and end resistance are synonymous for continuous rotation trimmers.

TEMPERATURE COEFFICIENT OF RESISTANCE: The unit change in resistance per degree Celsius change from a reference temperature, expressed in parts per million per degree Celsius as follows:

$$TC = \frac{R^2 - R^1}{R^1 (T^2 - T^1)} \times 10^6$$

Where:

R^1 = Resistance at reference temperature in ohms.

R^2 = Resistance at test temperature in ohms.

T^1 = Reference temperature in degrees Celsius.

T^2 = Test temperature in degrees Celsius.

RESISTANCE-TEMPERATURE CHARACTERISTIC: The difference between the total resistance values measured at a reference temperature of 25 °C and the specified test temperature expressed as a percent of the Total Resistance.

$$RTC = \frac{R^2 - R^1}{R^1} \times 100$$

Where:

R^1 = Resistance at reference temperature (25 °C) in ohms.

R^2 = Resistance at the test temperature in ohms.

CONTACT RESISTANCE VARIATION: The apparent resistance seen between the wiper and the resistance element when the wiper is energized with a specified current and moved over the adjustment travel in either direction at a constant speed. The output variations are measured over a specified frequency bandwidth, exclusive of the effects due to roll-on or roll-off of the terminations and is expressed in ohms or % of total resistance.

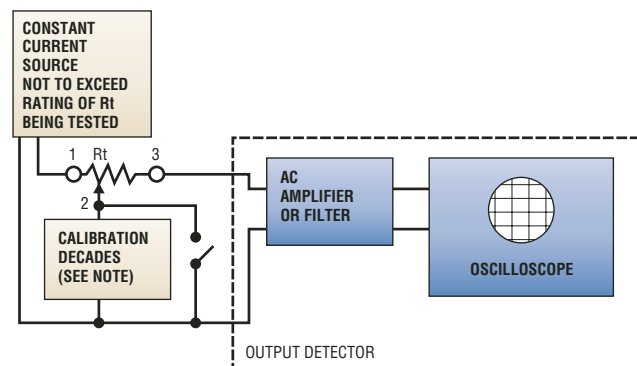

Where:

R_t = Test specimen

Output detector bandwidth = 100 cycles to 50 kilocycles

Minimum input impedance to output detector:

At least 10 times the nominal resistance being tested

Figure 1. Contact-resistance-variation measuring circuit

NOTE: At the calibration of the decade, terminals 1 and 2 must be coincident. Calibration decade is to be set for the contact-resistance variation (CRV) level of the specified nominal resistance being tested.

Applications/Processing Guide – Standard and Lead Free

Test Current ($\pm 20\%$)	Total Resistance Range
30 ma	$2 = R_t = 200$
5 ma	$200 < R_t = 3K$
1 ma	$3K < R_t = 200K$
200 ua	$200K < R_t = 1 \text{ megohm}$
50 ua	$1 \text{ megohm} < R_t = 5 \text{ megohm}$

EQUIVALENT NOISE RESISTANCE: Wirewound only. Any spurious variation in the electrical output not present in the input, defined quantitatively in terms of an equivalent parasitic, transient resistance in ohms, appearing between the contact and the resistive element when the shaft is rotated. The equivalent Noise Resistance is defined independently of the resolution, functional characteristics and the total travel. The magnitude of the Equivalent Noise Resistance is the maximum departure from a specific reference line. The wiper of the potentiometer is required to be excited by a specific current and moved at a specific speed.

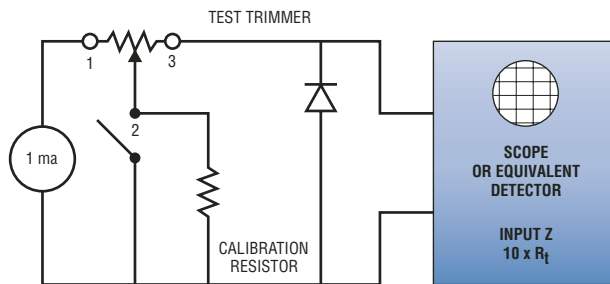

$$\text{ENR (ohms)} = \frac{\text{Max. Deviation (volts)}}{.001 \text{ amps}}$$

CONTINUITY: Continuity is the maintenance of continuous electrical contact between the wiper and both end terminals of the resistive element.

SETTING STABILITY: The amount of change in the output voltage, without readjustment, expressed as a percentage of the total applied voltage.

DIELECTRIC STRENGTH: The ability to withstand the application of a specified potential of a given characteristic, between the terminals and all other external conducting members such as shaft, housing and mounting hardware without exceeding a specified leakage current value.

INSULATION RESISTANCE: The resistance to a specified DC voltage impressed between the terminals and all other external conducting members such as shaft, housing and mounting hardware.

POWER RATING: The maximum power that a trimming potentiometer can dissipate across the total resistive element under specified conditions while meeting specified performance requirements.

ROTATIONAL LIFE: The number of cycles obtainable under specified operating conditions while remaining within specified allowable degradation. A cycle is defined as one complete traversal of the wiper over the resistive element in both directions.

LOAD LIFE: The number of hours at which a device may dissipate rated power under specified operating conditions while remaining within specified allowable degradations.

ADJUSTABILITY (OUTPUT RESISTANCE): The precision with which the output resistance of a device can be set to the desired value.

ADJUSTABILITY (OUTPUT VOLTAGE RATIO): The precision with which the output voltage ratio of a device can be set to the desired value.

Mechanical Terms

STARTING TORQUE: The maximum moment in the clockwise and counterclockwise directions required to initiate shaft adjustment anywhere in the mechanical travel.

STOP TORQUE: The maximum static moment that can be applied to adjustment shaft at each mechanical stop for a specified period of time without loss of continuity or mechanical damage affecting operational characteristics.

SOLDERABILITY: The ability of the terminals to accept a uniform coating of solder under specified conditions.

WELDABILITY: The ability of materials to be welded together under specified conditions.

TERMINAL STRENGTH: The ability of the terminals to withstand specified mechanical stresses without sustaining damage that would affect utility of the terminals or operation of the trimming potentiometer.

IMMERSION SEALED: The ability of the unit to withstand submersion in acceptable cleaning solutions used in normal soldering processes without performance degradation under specified environmental conditions.

Trimmer "Abilities"

When you are selecting components for a new design, you typically take into account the environmental conditions that the components will need to endure during the lifetime of the instrument or device. Designers in the past have often overlooked the environmental extremes of their own production lines, where the conditions may be much more severe than anything encountered in actual end use.

Applications/Processing Guide – Standard and Lead Free

Processability

“Processability” refers to the ability of the unit to withstand the production-line processes associated with the finishing steps on the PC boards. Typically, both SMT and through-hole products are subjected to similar PC board processing operations after preparation for assembly. These operations can generally be summarized as follows:

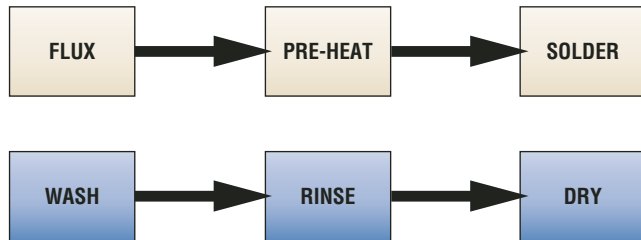

Soldering (SMT)

Four types of equipment are usually associated with SMT soldering:

IR System — Uses a multi-zone infrared furnace with IR elements heated to a temperature substantially above chamber or product temperature. Energy is supplied to the product primarily by IR radiation to reflow solder.

Forced Hot Air Convection System — Uses a multizone forced air convection system with heat source panels using IR or other type heating elements. Approximately 85 % of the heating is provided by free convection to reflow solder on exposed PC boards.

Dual Wave System — Utilizes two parallel solder waves. The first is a turbulent wave followed by a laminar wave. The turbulent wave is for small, constricted areas, while the laminar wave removes solder projections.

Vapor Phase System — Provides a single-zone condensation heat source achieved with liquid fluorinated hydrocarbons that have been brought to the boiling point to create a saturated vapor zone. Heat is then released by the fluid’s heat of vaporization as the vapor condenses on the product.

Soldering (Through-hole)

Two types of equipment are usually associated with through-hole soldering:

Single Wave System — Provides an inclined portion of the solder wave for the PC board to pass over. The PC board is positioned to bring many potential solder joints in contact with the wave simultaneously for a short time for soldering.

Drag System — Provides for PC boards to be dragged across the surface of the solder pot. Soldered connections are made during this operation.

PC Board Washing

Two types of equipment are usually associated with both SMT and through-hole products.

Pressure System — Accomplishes cleaning by directing sprays of water under high pressure from multiple nozzles.

Flooding System — Utilizes a combination of flooding (at normal water pressure) and surfactant action for cleaning.

Soldering and Wash Processes

Figure 1 shows typical profiles any component may see during a soldering and board washing operation. For details of material and process variables recommendations, see “Soldering and Cleaning Processes”, page 152.

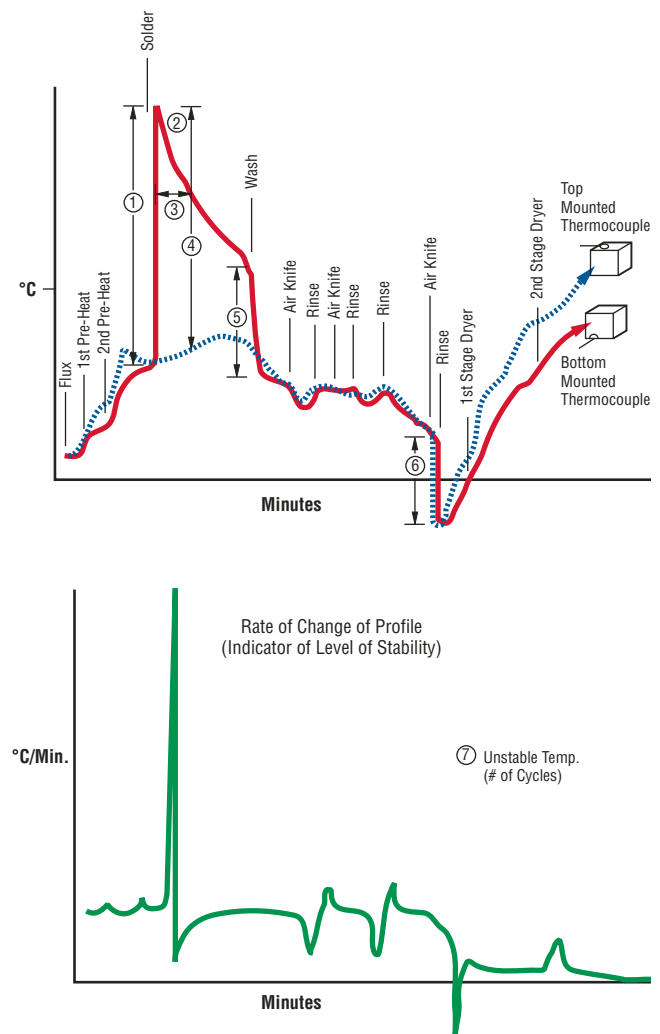

Figure 1
Typical temperature profile for board washing and soldering.

Critical profile parameters

- ① Temperature Shock (°C)
- ② Maximum Temperature (°C)
- ③ Temperature Exposure (Minimum)
- ④ Temperature Gradient (°C)
- ⑤ Temperature Shock Decrease in Water (°C)
- ⑥ Temperature Shock Decrease in Water & Air Pressure (°C)
- ⑦ Unstable Temperature

Applications/Processing Guide – Standard and Lead Free

General Guidelines for Guarding Against Component Damage

To minimize temperature shock

- Pre-heat boards to maximum acceptable level
- Reduce time in solder

To avoid heating components above their maximum rated temperature

- Use lowest acceptable solder temperature
- Use maximum allowable conveyor speed
- Limit pre-heat temperature to maximum necessary

To limit time of exposure above rated temperature

- Limit time in solder
- After solder operation, cool board to wash temperature before it enters wash

To minimize temperature difference between top and bottom of board

- Apply pre-heat to both top and bottom

To reduce temperature shock on entering the moist environment of the wash

- Use wash/rinse temperature as near component temperature as possible
- Extend time between solder process and wash
- Cool board after solder operation, prior to entering wash

To minimize temperature variations as component travels through moisture

- Minimize number of wash/rinse and rinse/dry cycles
- Use heated air for air knives (to counter evaporative cooling effect)
- Minimize difference between wash and rinse temperature

To minimize exposure to high-pressure water during board wash

- Select trimmer models with pin styles that orient the rotor seal area away from exposure to the high-pressure water stream

Settability

Settability refers to the ease with which a trimmer can be set accurately to the position that produces the desired circuit condition.

Where the requirement is for obtaining a highly accurate setting the preference is for cermet — because a small incremental adjustment in a wirewound unit does not always produce the expected change in output as the wiper moves off one turn of wire and onto another.

Setting accuracy is better with a multiturn unit than with a single-turn. This is especially true when the speed of setting is also a requirement as on a production line (Figure 2).

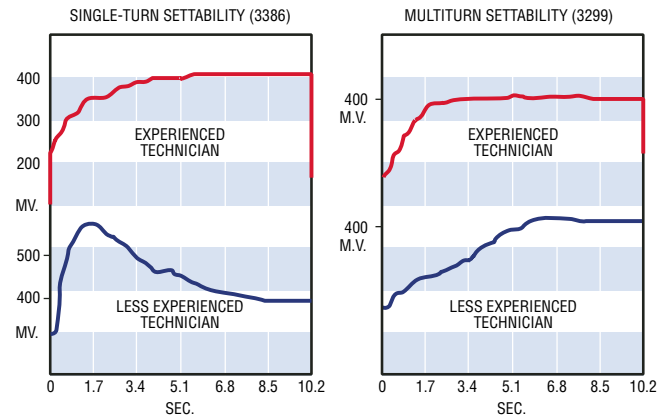

Figure 2.
When accurate setting is required, a multiturn trimmer can generally be set faster than a single-turn.

Stability

Stability refers to the ability of the trimmer to remain at the desired setting. Environmental factors play an important role here: stability may be affected by temperature exposure, thermal shock/cycling, humidity, and mechanical shock or vibration.

This is not a matter of concern in most applications, since Bourns® trimmers exhibit excellent stability under all specified conditions. Stability is most often a concern when cermet trimmers are used in low current “dry” circuits (50 uA and below). Under these conditions the contact resistance may vary, making the wiper appear unstable. This is most noticeable in some rheostat applications. This can be avoided by using a wirewound unit, or choosing a cermet trimmer that has been designed for dry-circuit applications. Bourns applications engineers can assist you on this and other questions.

Accessibility

When selecting a trimmer and determining its placement on the board, keep in mind the people who will have to use it. Bourns® trimmers are available in a wide variety of sizes, shapes, configurations, and placement of adjustment screws. You will usually find a unit on which the access for adjustment will be convenient for the user.

Keep in mind the different requirements for accessibility depending on whether adjustment will be done on the assembly line or in the field; with the board uncovered, in a housing or cabinet, or on an extender. Also consider whether production-line adjustment will be done manually or by robotics. A Bourns applications engineer can advise on special high-speed automatic adjustment features.

Applications/Processing Guide – Standard and Lead Free

Usability

In selecting a trimmer for a specific application, it's important to be aware that the catalog contains a myriad of facts about each model that can assist you in finding the most suitable choice. For example:

Contact Resistance Variation (CRV) — Under MIL-R 22097 and MIL-R-39035, the maximum CRV is 3 %. All Bourns® trimmers meet this standard (3 % or 3 ohms, whichever is greater). For applications that demand a more rigorous standard, some Bourns® trimmers are rated at 2 % or 2 ohms, and many others at 1 % or 1 ohm.

Power Rating — The ambient temperature at which the trimmer will operate has an important bearing on power rating. Power ratings are usually specified at 70 ° or 85 °C; at a temperature of 150 °C, the power rating of many trimmers is reduced to zero.

Temperature Coefficient of Resistance (T.C.) — This specification is a measure of how much the resistance changes with a change in temperature. In many applications a T.C. of ± 250 PPM/°C is acceptable. Typical T.C. specifications for cermet models are ± 100 PPM/°C and ± 50 PPM/°C for wirewound models.

Lead Free Solder Reflow Profile – SMD Trimmers

Process Description	Materials	Temperature	Time Interval
1. Apply solder paste to test board (8 - 10 mil thick)	<ul style="list-style-type: none"> • Sn Ag Cu Alloy water soluble or no clean solder paste¹ • Single sided epoxy glass (G10) (UL approved) • PC board approx. 4x4x.06 in. 	Room temperature	
2. Place test units onto board	6 units/board	(see note 2)	
3. Ramp up	Convection oven		2.5 °C ±0.5 °/second
4. Preheat		150 °C to 190 °C	90 +30 seconds
5. Time above liquidus		220 °C	60-90 seconds
6. Peak temperature			260 °C +0/-5 °C 10-20 sec. within 5 °C of peak
7. Ramp down		Room temperature ²	3 °C ±0.5 °C/second
8. Cleaning water clean profile ⁵	High pressure deionized water 65 PSI maximum	72 °F to 160 °F (22 °C to 71 °C)	As required

Inspect solder joint to determine if solder joint is acceptable (i.e. exhibits wetting of joint's surface). Use the following criteria (ref. acceptability of printed board assemblies, IPC-610A):

A) Acceptable (see Figure 1)

- (1) Feathered edges
- (2) Concave fillet
- (3) Fillet appears smooth

B) Unacceptable (see Figure 2)

- (1) Convex fillet
- (2) Solder balls (5 balls or more per square inch)

If unacceptable, determine cause and correct prior to next run.

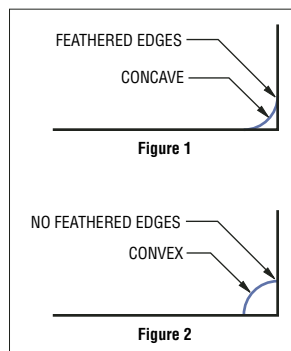

Temperature of Lead/Pad Junction

(Derived using 6-zone Convection Oven)

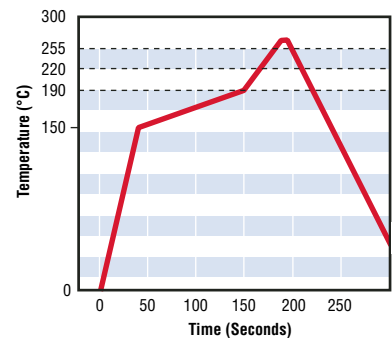

NOTES:

1. Water soluble solder paste only above 100K.
2. Refer to ref. temperature profile. Temperature at lead/pad junction with "K" type thermocouple.
3. Units that are board mounted for environmental testing must see a peak temperature in the reflow zone, as specified.
This is to ensure that all test units will see "worst case conditions".
4. Ramp down rate to be measured from 255 °C to 150 °C.
5. Process Description 8 does not apply to open frame trimmers.

Specifications are subject to change without notice.
Customers should verify actual device performance in their specific applications. REV 04/04

Standard Soldering and Cleaning Processes

This application note is designed to provide step-by-step processing recommendations. It covers the popular Surface Mount Component (SMC) soldering processes currently in use and provides recommendations and cautions for each step. Since many variations of temperature, time, processes, cleaning agents and board types are found in the

electronics industry, you'll want to test and verify your own system.

The process steps, recommendations and cautions are based on Bourns® Trimpot® surveys of SMC users, equipment manufacturers and materials suppliers. Also, comments reflect results of Bourns testing. Our findings suggest the following soldering and cleaning processes:

1. SOLDERING – Forced Hot Air, Convection, IR, Vapor Phase (In-Line), Wave (Single and Dual)
2. CLEANING – Solvent, Aqueous, Semi-Aqueous, No-Clean

On the facing page are the common methods, materials and maximum temperature/time parameters for soldering and cleaning processes.

1

Solder Paste Printing

Reflow

GENERAL

Use the optimum solder paste for the pattern, printing process, solder paste density and solder joint quality.

RECOMMENDED

Use Sn 63 % Pb 37 % solder paste. Use 8 to 10 mil thickness for solder paste print.

CAUTION

Since solder paste usually contains a high percentage of activators, you must ensure adequate cleaning to remove all residues, unless no-clean (low solids) paste is used.

2

Adhesive Application

Flow (Wave)

GENERAL

The adhesive must hold the SMC in correct orientation upon placement and maintain correct trimmer position during physical handling before final solder processing.

RECOMMENDED

To assure positional stability, place a single dot of epoxy under the SMC.

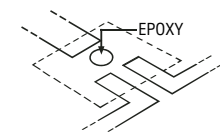

CAUTION

Stability after placement is a direct function of the volume of adhesive used. Use enough epoxy to assure stability through the cure process.

Avoid overflow of epoxy to solder pad and terminal areas.

3

SMC Placement

GENERAL

Use pick-and-place equipment with vacuum nozzle ID size that allows adequate suction to pick the SMC out of the embossed cavity.

RECOMMENDED

The nozzle inside diameter (ID) should not exceed .100 in. (2.54 mm) to ensure adequate suction and part alignment.

CAUTION

Assure parts are placed so that all terminals are equidistant (<4 mils) from the solder pads.

Align terminals with solder belt direction of travel to avoid body shadowing effects during flow soldering.

4

Adhesive Cure

Flow (Wave)

GENERAL

Use heat/time cure method with either convection oven or infrared radiation.

RECOMMENDED

Cure using the temperature and times recommended by the adhesive manufacturer.

CAUTION

Use enough cure time to assure complete adhesive transition from fluid to solid.

5

Flux Application

Flow (Wave)

GENERAL

Use the correct flux to remove surface oxides, prevent reoxidation and promote wetting.

RECOMMENDED

- RMA
- No-clean SRB (Synthetic Resin Based)
- OA (Organic Acid) (See caution)

CAUTION

Avoid highly activated fluxes. Consult factory before using OA.

Standard Soldering and Cleaning Processes

6



Solder

Reflow; Hot Air, IR and Vapor Phase

GENERAL

Preheat sufficiently using both time and temperature to vaporize all solder paste solvents and moisture, leaving only solder and flux as component enters solder reflow phase.

RECOMMENDED

Solder zone profile of 230 °C for 20 seconds.

CAUTION

Do not exceed time and temperature reflow profile of 235 °C for 45 ±5 seconds for hot air/IR reflow and 215 °C for 3 minutes for vapor phase reflow. Use 215 °C as minimum reflow temperature.

Minimize thermal shock by limiting temperature rise rate to 3 °C/sec and by stabilizing board and components temperature during preheating.

7



Solder

Flow (Wave)

GENERAL

For maximum component reliability and performance, minimize the time of temperature exposure above 200 °C.

RECOMMENDED

Use SN 63 % Pb 37 % solder. Solder zone profile of 245 °C for 5 seconds.

CAUTION

Do not exceed 260 °C peak temperature for dual wave solder process with a flow zone totaling 5 seconds.

Minimize thermal shock by limiting temperature rise rate to 3 °C/sec and by stabilizing board and components temperature during preheating.

8



Wash

Solvent

GENERAL

Use solvent cleaning primarily for nonpolar contaminants such as rosin based flux residues.

RECOMMENDED

Use any suitable washing solvents that meet ODC requirements.

CAUTION

Limit excessive direct spray pressure to 60 psi or below for optimum reliability.

9

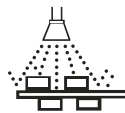

Wash

Semi-Aqueous

GENERAL

Use semi-aqueous for nonpolar contaminants such as rosin based flux residues.

RECOMMENDED

Use terpene or hydrocarbon based for pre-wash. Use water for final wash.

CAUTION

Limit excessive direct spray pressure to 60 psi or below for optimum reliability.

10

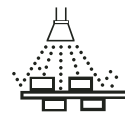

Wash

Aqueous

GENERAL

Use aqueous cleaning primarily for polar contaminants such as organic flux residues.

RECOMMENDED

Use any of these aqueous wash materials:

- Deionized water
- Surfactants
- Saponifiers

CAUTION

Limit excessive direct spray pressure to 60 psi or below for optimum reliability. Ultrasonics may cause component damage or failure.

11

No-Wash

GENERAL

No-wash is an option when no-clean (low solids) flux is used for solder operations.

Board Rework Technique



GENERAL

Excessive and/or repeated high temperature heat exposure may affect component performance and reliability.

RECOMMENDED

Hot air reflow technique is preferred.

CAUTION

Avoid use of a soldering iron or wave soldering as a rework technique.

Standard Soldering/Cleaning Methods

Process Step	Reflow							
	Hot Air Infrared (Solvent)	Hot Air Infrared (Semi-Aq.)	Hot Air Infrared (Aqueous)	Hot Air Infrared (No Clean)	Vapor Phase (Solvent)	Vapor Phase (Semi-Aq.)	Vapor Phase (Aqueous)	Vapor Phase (No Clean)
1. Solder Paste Printing	◆	◆	◆	◆	◆	◆	◆	◆
2. Adhesive Application								
3. Component Placement	◆	◆	◆	◆	◆	◆	◆	◆
4. Adhesive Cure								
5. Flux Application								
5. Flux Application								
5. Flux Application								
5. Flux Application								
6. Solder (Reflow)	◆	◆		◆	◆	◆	◆	◆
7. Solder (Flow)								
8. Wash (Solvent)	◆				◆			
8. Wash (Semi-Aqueous)		◆				◆		
8. Wash (Aqueous)			◆				◆	
High Pressure Fluids			◆				◆	
Max. Temp. (°C)/Time (Sec.)	235/40	235/40	235/40	235/40	215/180	215/180	215/180	215/180
Min. Temp. (°C)	215	215	215	215	215	215	215	215

Standard Soldering/Cleaning Methods

	Flow				Material
	Wave (Solvent)	Wave (Semi-Aqueous)	Wave (Aqueous)	Wave (No Clean)	
	♦	♦	♦	♦	
	♦	♦	♦	♦	
	♦	♦	♦	♦	
	♦				Rosin
		♦			Rosin
			♦		Organic Acid
				♦	Synthetic Resin Based
					63/37 Sn/Pb
	♦	♦	♦	♦	63/37 Sn/Pb
	♦				ODS Free
		♦			Terpene, Hydrocarbon Based
			♦		DI H2O; Surfactant; Saponifier
			♦		(See Caution)
	260/5	260/5	260/5		
	215	215	215		

Factory Installed Panel Mount

Trimpot® Potentiometer Panel Mounting Options and Hardware

Many Trimpot® Potentiometers are available for panel mount application.

This product option provides for maximum design flexibility.

To order Trimpot® Potentiometers with panel mount hardware attached by the factory, simply add an "M" or "Z" suffix to the Bourns® part number per Table I.

Example:

3006P-1-100Z

To order military Trimpot® Potentiometers with panel mount hardware attached by the factory, order the military part number and add "with panel mount attached."

Example:

RT12C2103M, with panel mount attached.

To order panel mounting accessories for customer installation, simply use the part number per Table II.

Example:

H83P

NOTE: For complete product specifications, see catalog page for the trimmer model.

Torque – Apply maximum 8 in. lbs. on mounting nut when mounted on panel.

Models RT12/RJ12, 3057/3059

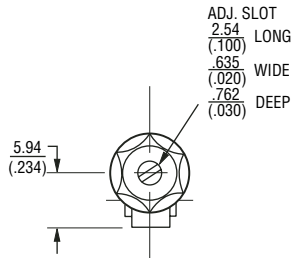
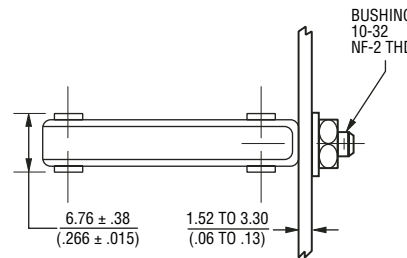
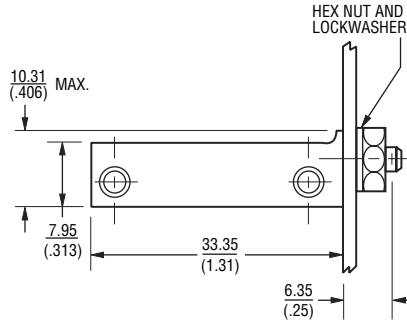

Notes:

1. Provided with lockwasher and mounting nut.
2. Recommend panel holes. #10 drill .194/(.008)

Models 3005/3006/3009

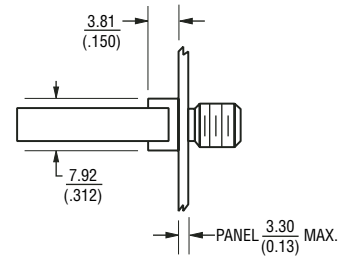
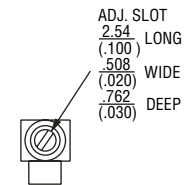
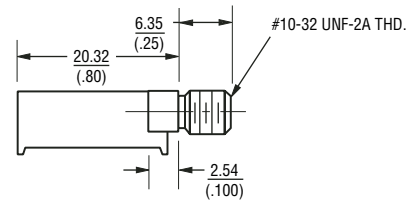
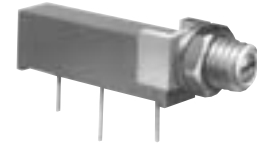

Notes:

1. Provided with lockwasher and mounting nut.
2. Recommend panel holes. #7 drill .200/(.008)

DIMENSIONS: MM/(INCHES)

Specifications are subject to change without notice. Customers should verify actual device performance in their specific applications. REV 05/04

Factory Installed Panel Mount

Models 3292

X, L and W Styles

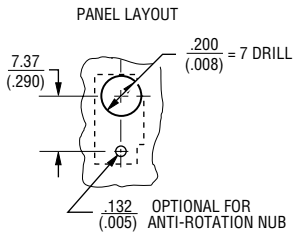
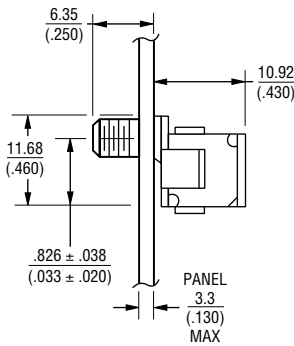
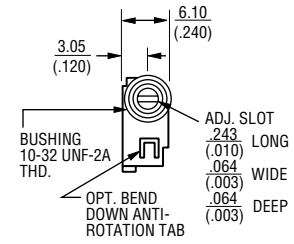

Notes:
1. Provided with lockwasher and mounting nut.

Models RT22/RTR22/RJ22 3250/3252

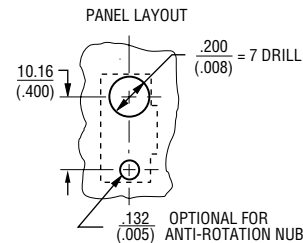
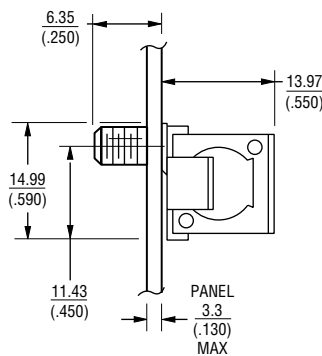
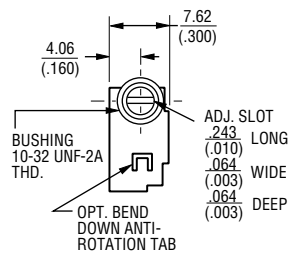
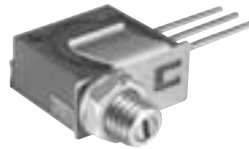

Notes:
1. Provided with lockwasher and mounting nut.

Models RT24/RTR24/3290

H and W Styles – 3290
X & W Styles – RT24/RTR24

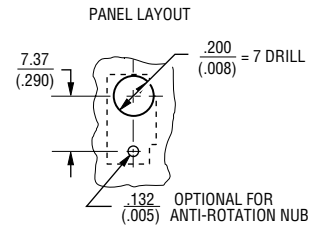
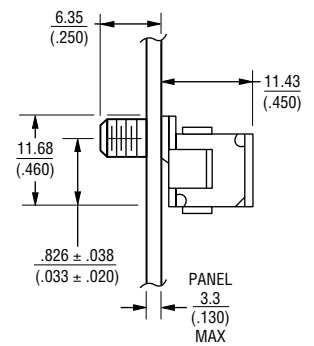
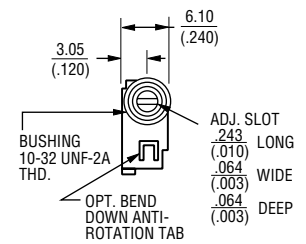

Notes:
1. Provided with lockwasher and mounting nut.

DIMENSIONS: MM/(INCHES)

Customer Installed Panel Mount – Unsealed

See Table II for panel mount part number

H-58P Panel Mount

1-1/4 Inch Rectangular Multiturn Modules

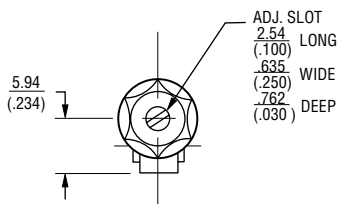
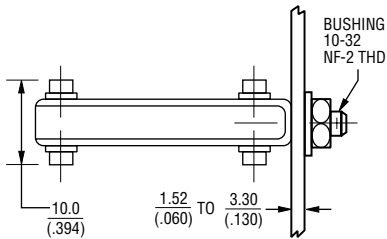
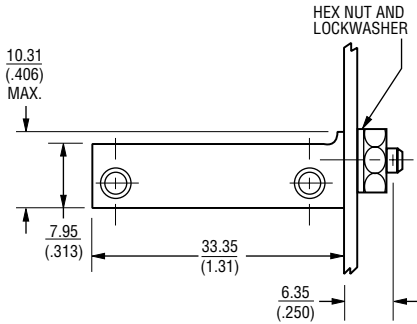

- Notes:
1. Provided with lockwasher and mounting nut.
 2. Recommend panel holes. #10 drill .194/(.008)

*Specify H82 if panel Seal is required.

Specifications are subject to change without notice.
Customers should verify actual device performance in their specific applications.
REV 05/04

H-65P Panel Mount

1/2 Inch Square Multiturn Models

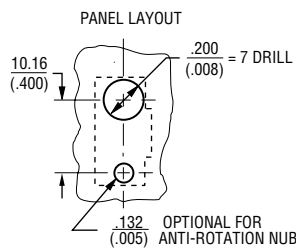
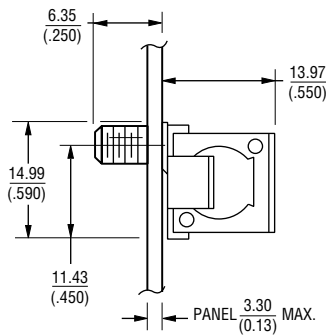
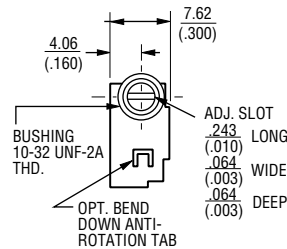
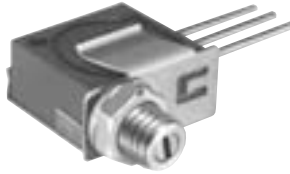

- Notes:
1. Provided with lockwasher and mounting nut.
 2. Drawings shown with Trimmer. Order part separately.

H-83P Panel Mount

Adapter for Models 3005 AND 3006

The H-83P Adapter is used with Models 3005 and 3006. Order separately and simply snap fit the trimmer in the plastic case. The H-83P with lock-washer and mounting nut is available in 50-piece lots.

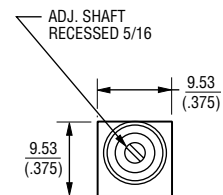
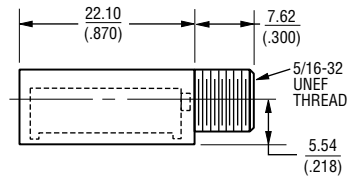

- Notes:
1. Drawings shown with Trimmer. Order part separately.

DIMENSIONS: MM/(INCHES)

Customer Installed Panel Mount

3/8 Inch Square Multiturn Models

H-114P/115P/116P Panel Mount

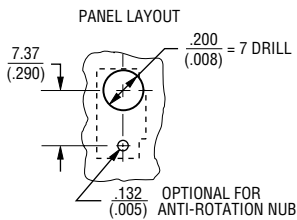
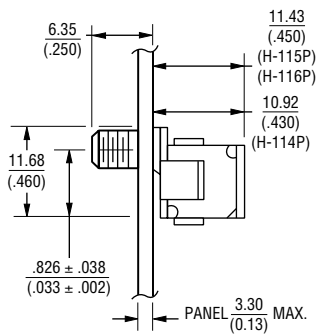
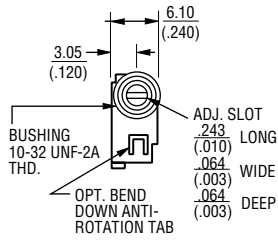

Notes:
 1. Provided with lockwasher and mounting nut.
 2. Drawings shown with Trimmer. Order part separately.

H-117P Panel Mount

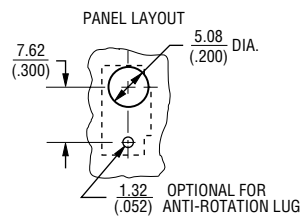
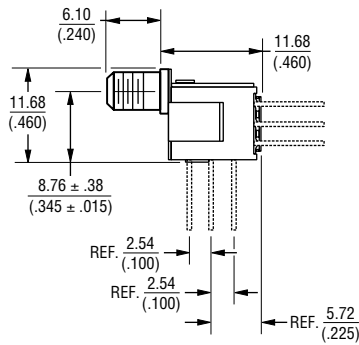
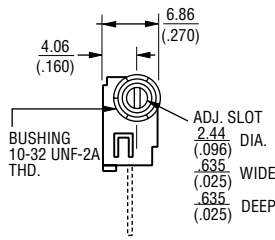

Notes:
 1. Provided with lockwasher and mounting nut.
 2. Drawings shown with Trimmer. Order part separately.

Table I – Factory Installed Panel Mounts

Standard Part Number	Part Number with Panel Mount
3005P-1-(RC)	3005P-1-(RC) Z
3006P,Y, or W-1-(RC)	3006P,Y, or W-1-(RC) Z
3009P or Y-1-(RC)	3009P or Y-1-(RC) Z
3057L,J,P or Y-1-(RC)	3057L,J,P or Y-1-(RC) M
3059L,J,P or Y-1-(RC)	3059L,J,P or Y-1-(RC) M
3250L or W-1-(RC)	3250L or W-1-(RC) M
3252L or W-1-(RC)	3252L or W-1-(RC) M
3290H or W-1-(RC)	3290H or W-1-(RC) M
3292L,W or X-1-(RC)	3292L,W or X-1-(RC) M
3296W or X-1-(RC)	3296W or X-1-(RC) M

Table II – Retro-Fit Panel Mounts

For installation by customer

Standard Part Number	Order Panel Mount Part Number
3005P-1-(RC)	H-83P
3006P,Y, or W-1-(RC)	H-83P
3057L,J,P or Y-1-(RC)	H-58P* Screw Assembly
3059L,J,P or Y-1-(RC)	H-58P* Screw Assembly
3250L, W, X-(RC)	H-65P-1*
3252L, W-1-(RC)	H-65P-3*
3252X-1-(RC)	H-65P-5*
3290H or W-1-(RC)	H-114P*
3292L-1-(RC)	H-115P*
3292W or X-1-(RC)	H-116P*
RT12P,Y,L	H-58P* Screw Assembly
RJ12L,P,Y	H-58P* Screw Assembly
RT22L,W,X / RTR22L,W,X	H-65P-1*
RJ22L,W	H-65P-3*
RJ22X	H-65P-5*
RT24W / RTR24W or X	H-114P*
RJR24W or X	H-117P*

*Specify H-82 if panel seal is required.

Hardware for Special Mounting Applications

H-82 Panel Seal

For all panel mounts with size 10-32 bushings.

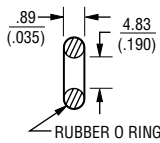
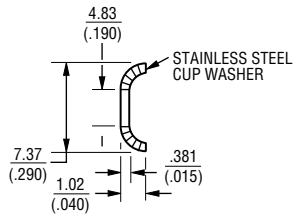

To be used with the following to provide panel seal:

- H-58P
- H-65P-1
- H-65P-3
- H-65P-5
- H-114P
- H-115P
- H-116P
- H-117P

H-25/H-28 Stacking Straps

Models 3250, 3252 (H-25) and 3292 (H-28).

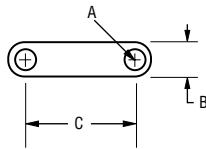

Dimensions	H-25	H-28
A	.236 (.093)	.178 (.070)
B	.363 (.143)	.318 (.125)
C	1.321 (.520)	1.064 (.419)
Thickness	.51 (.02)	

H-26S Side Bracket

Models 3250 and 3252. This hardware is available for special mounting applications.

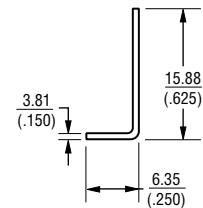
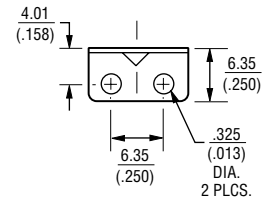
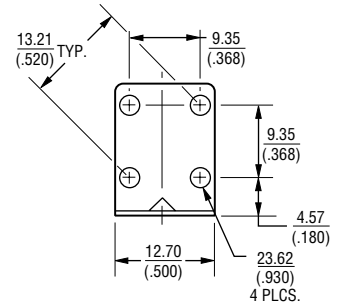

DIMENSIONS: MM/(INCHES)

Specifications are subject to change without notice. Customers should verify actual device performance in their specific applications. REV 05/04



H-90/H-91/H-92-1 Adjustment Tools

Features

- Meets UL 94V-0
 - Pocket clip
 - For use on most trimmer shafts/rotors
 - Recessed end for use with extended shafts
- H-90 & H-91 available in blue;
 - H-92-1 available in off-white

BOURNS®

H-90

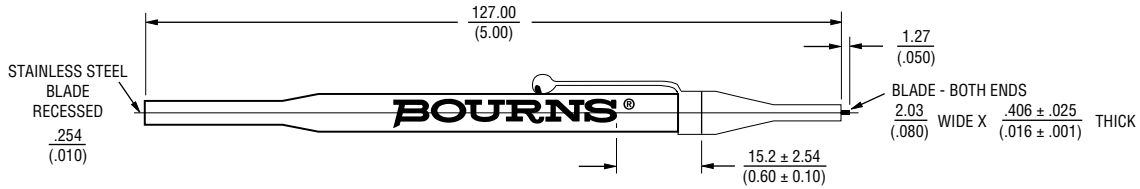

H-91*

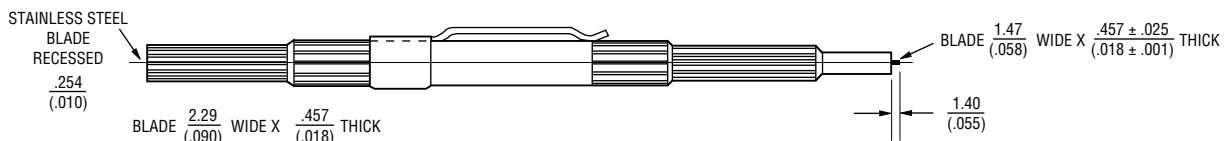

***H-91 RECOMMENDED FOR USE WITH TRIMMER MODELS 3224 AND 3214.**

H-92-1*

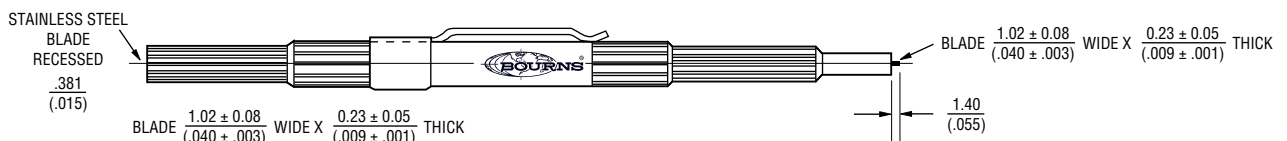

***H-92-1 RECOMMENDED FOR USE WITH TRIMMER MODELS 3342, 3223 AND 3213.**

Specifications are subject to change without notice.
Customers should verify actual device performance in
their specific applications. REV 09/04

DIMENSIONS: MM/(INCHES)



Design Kits: Trimming Potentiometers

Trimming potentiometers perform a variety of circuit adjustments in all types of electronic equipment. The variety of physical configurations available and the ability to withstand today's manufacturing environment offers the designer flexibility in selecting the best trimmer for the application. Around the world, trimmers are used in virtually every electronic market.

BOURNS®

Part Numbers

Each kit contains samples of each of the part numbers. Part numbers could change based on latest offering. Refer to website – additional kits may be available.

Kit Numbers			
H-814-2	H-840	H-841	H-851
3223W-1-501E	3006P-1-502	3302W-3-103E	3223W-1-201E
3223W-1-502E	3214G-1-502	3303W-3-102E	3223W-1-102E
3223W-1-103E	3223W-1-103	TC33X-2-502E	3223W-1-502E
3223W-1-104E	3224J-1-103	3306F-1-202	3223W-1-103E
3223W-1-105E	3224W-FW5-203	3306K-1-104	3223W-1-503E
3224W-1-501E	3266W-1-203	3306P-1-101	3223W-1-104E
3224G-1-502E	3269W-1-502	3306W-1-502	
3224W-1-103E	3296W-1-203	3309P-1-204	
3224G-1-104E	3299W-1-503	3309W-2-101	
3224W-1-105E	3313J-1-203	3309W-1-502	
3269W-1-501G	3314G-1-102	3318F-1-103	
3269P-1-502G	3329H-1-102	3318K-1-103	
3269W-1-103G	3339P-1-503	3318P-1-203	
3269P-1-104G	3361P-1-103	3318G-1-102A	
3269W-1-105G	3361S-1-104	3318S-1-502A	
3313J-1-501E	3362P-1-203	3319P-2-103	
3313J-1-502E	3386W-1-103	3319P-3-203	
3313J-1-103E	3386P-1-102T	3319W-1-503	
3313J-1-104E			
3313J-1-105E			
3314J-1-501E			
3314G-1-502E			
3314J-1-103E			
3314G-1-104E			
3314J-1-105E			
TC33X-2-501E			
TC33X-2-502E			
TC33X-2-103E			
TC33X-2-104E			
TC33X-2-105E			
H-91 Adjustment Tool			



BOURNS®

Design Kit: Linear Motion Potentiometers

A spin-off of the trimming potentiometer product line, the linear motion potentiometer was developed to meet the needs of designers wishing to detect movement of position. Applications for these compact components include: Solenoid positioning sensors for automated controllers, volume control on audio equipment, joystick controllers, satellite dish positioning, and robotics.

Part Numbers

Each kit contains samples of each of the part numbers. Part numbers could change based on latest offering. Refer to website – additional kits may be available.

Kit Number
H-848
3048L-2-103
3046L-1-103
3048L-5-203
3046L-3-203



BOURNS®

Design Kits: Modular Contacts

Bourns Modular Contacts are off-the-shelf interconnect devices that can be used in cellular telephones, PDAs, laptop computers, portable medical and test equipment; anywhere a rechargeable battery pack is required. Because they can be used as either compression or sliding Modular Contacts, they can function as connectors for many other non-battery related applications.

Part Numbers

Each kit contains samples of each of the part numbers. Part numbers could change based on latest offering. Refer to website – additional kits may be available.

Kit Numbers	
H-839	H-843
70ADJ-5-ML0/1	70AAJ-6-M0
70ADJ-5-FL0/1	70AAJ-6-F0
70ADJ-3-ML0/1	70AAJ-4-M0
70ADJ-3-FL0/1	70AAJ-4-F0
70ADH-2-ML0	70AAJ-3-M0
70ADH-2-FL0	70AAJ-3-F0
	70AAJ-2-M0
	70AAJ-2-F0



Design Kits: Switches

Bourns switches are low voltage, low current, signal level devices designed for selection, operation or programming. Key and tactile switches are push/momentary devices. Rotary switches are single-pole, double-throw devices. DIP switches are dual in-line, double pole with 1 to 12 positions. Switch applications include instrumentation, industrial controls, communications equipment, computers, security systems, appliances, automotive, audio/visual and pagers.

Part Numbers

Each kit contains samples of each of the part numbers. Part numbers could change based on latest offering. Refer to website – additional kits may be available.

Kit Numbers		
H-845	H-846	H-847
7813J-1-023	7914J-1-000	SDMR-4-T
7813S-1-051	SDTA-610-K	SDMX-4-X
7814G-1-023	SDTG-630-N	SDMX-8-X
7814J-1-051	SDTM-620-N	SNDX-3H-X
7814H-1-023	SDTX-650-R	SNDR-4H-T
7814Z-1-051	STHW-660-N	SNDR-6S-T
7829H-1-023	STJN-405-N	SNDX-8H-X
7829S-1-051	STJN-515-N	SNDR-9H-T
	STJW-680-S	
	STMW-690-R	
	STSM-31-S	
	STSM-32-S	



Worldwide Sales Offices

Country	Phone	Fax
Benelux:	+31-70-3004333	+31-70-3004345
Brazil:	+55 11 5505 0601	+55 11 5505 4370
China:	+86-21-64821250	+86-21-64821249
France:	+33-254-735151	+33-254-735156
Germany:	+49-69-80078212	+49-69-80078299
Hong Kong:	+852-2411 5599	+852-2412 3611
Ireland:	+44-1276-691087	+44-1276-691088
Italy:	+39-02-38900041	+39-02-38900042
Japan:	+81-49-269 3204	+81-49-269 3297
Singapore:	+65-63461933	+65-63461911
Switzerland:	+41-41-7685555	+41-41-7685510
Taiwan:	+886-2-25624117	+886-2-25624116
UK:	+44-1276-691087	+44-1276-691088
USA:	+1-951-781-5500	+1-951-781-5700
Non-Listed European Countries:	+41 (0)41 768 5555	+41 (0)41 768 5510

Technical Assistance

Region	Phone	Fax
Asia-Pacific:	+886 2 25624117	+886 2 25624116
Europe:	+41 (0)41 768 5555	+41 (0)41 768 5510
North America:	+1-951-781-5500	+1-951-781-5700

www.bourns.com

Bourns' products are available through an extensive network of manufacturer's representatives, agents and distributors. To obtain technical applications assistance, a quotation, or to place an order, contact a Bourns representative in your area.

Specifications subject to change without notice. Actual performance in specific customer applications may differ due to the influence of other variables. Customers should verify actual device performance in their specific applications.



Reliable Electronic Solutions

"Bourns" and "Trimpot" are registered trademarks of Bourns, Inc. in the U.S. and other countries.

COPYRIGHT © 2004, BOURNS, INC. • LITHO IN U.S.A. • SP 10/04 • 15M/TO435