

AB CONTROLS & CONNECTORS LIMITED

*ABW1
ABW3*

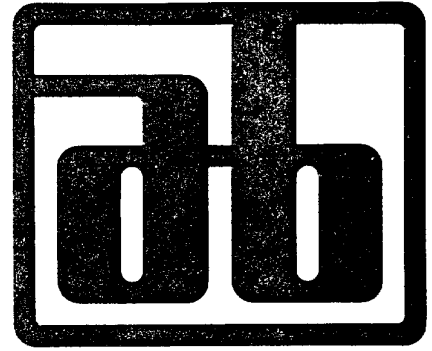

WIREWOUND POTENTIOMETERS

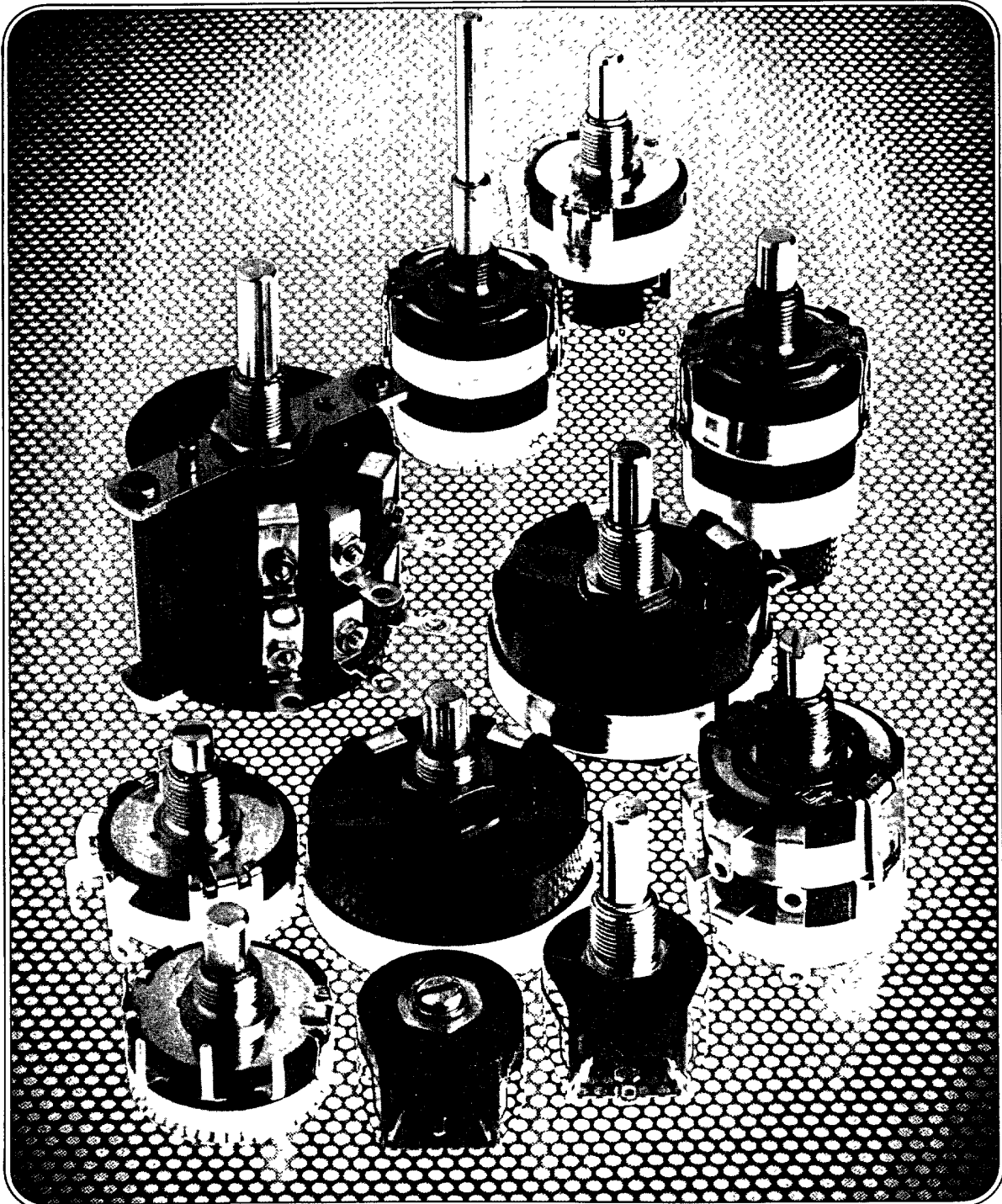

Series ABW1 Wirewound Potentiometer

The ABW1 Series of Potentiometers have for many years been the Industry standard for professional and industrial applications. The design ensures a very high degree of linearity and concentricity between the wiper and the element. The design has been updated and a 'clip on' moulded cover is now fitted.

Electrical specification

Effective Rotation

$265^\circ \pm 5^\circ$

Resistance Range

1 Ω to 50K Ω linear
20 Ω to 10K Ω log

Resistance Tolerance

Standard: $\pm 10\%$

Special: $\pm 5\%$, $\pm 2\%$, $\pm 1\%$ (Values $>47\Omega$)

Laws

Linear, Non-linear

Non-linear functions are achieved by former profiling or by using up to three linear sections of varying resistance gradients.

Special non-inductive types available.

Linearity

Standard: Independent 2%

Special: 1%

Voltage Rating

300V d.c.

Resolution

Can be determined from Resolution v Resistance graph. If degree of resolution is a particular requirement customer should state this in specification.

Power Rating at 40°C Ambient Temperature

Linear: 1 Watt

Non-linear: Dependent on exponent of the law.

E.N.R.

Not greater than 100 Ω .

Voltage Proof

1 kV r.m.s.

Insulation Resistance

Not less than 1000M Ω at 500V d.c.

Terminal Resistance

Not greater than 0.01% of nominal resistance or 0.2 Ω whichever is the greater.

Mechanical specification

Mechanical Rotation

$285^\circ \pm 5^\circ$

Operating Torque

0,7 – 3,6 Ncm.

Mounting Details

Standard Bush: Bush 9,5mm diameter, 32 TPI Whitworth form 10mm long, or metric M10 \times 0,75/10mm long. Annular ring designed to fit over the bush can be supplied to provide a locating key position 9,5mm left of centre (terminals down, viewed from spindle end) or a locating key to DIN requirements.

Panel and spindle sealing available to R.C.L.224.

Printed Circuit: The flat edge and stand offs of the moulded body are designed to facilitate such mounting.

End Stop Torque

113 Ncm minimum

Spindles

Diameter: 6,3mm or 6mm

Standard lengths: 12,7mm, 15,9mm, 19mm, 25,4mm

Round with screwdriver slot.

Other lengths and end configuration to customers' requirements.

With a locating key ring the mounting face is brought forward by 0,81mm.

Terminals

Standard: Solder lug or printed circuit (silver plated)

Special: Gold washed or gold plated terminals can be provided.

Resolution and Temperature Coefficient v Resistance (Typical)

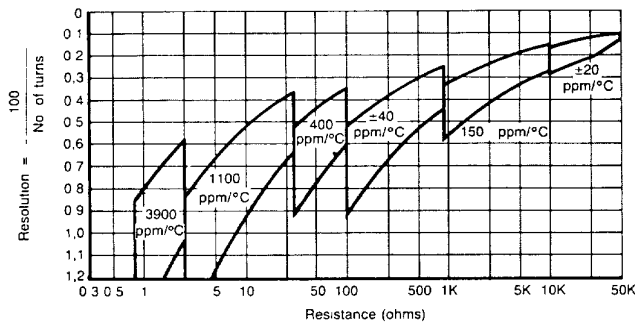

DERATING CURVE

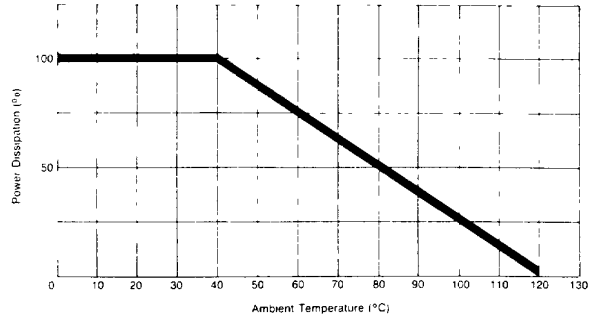

Type ABW1 Solder lug terminals and standard locating key.

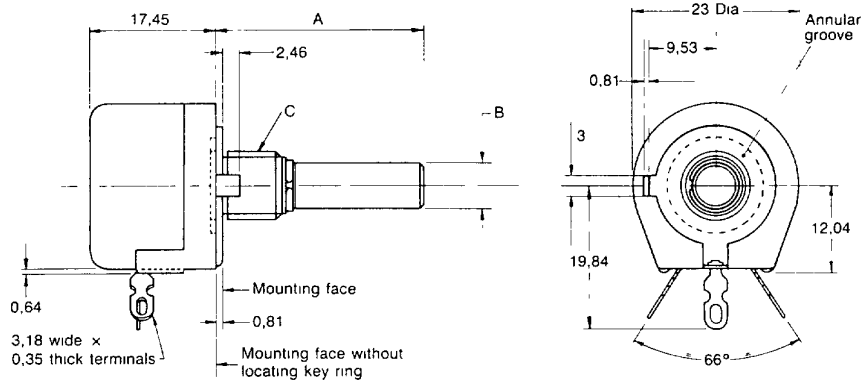
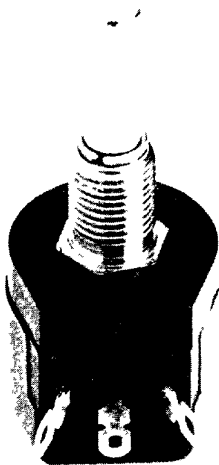

Printed circuit terminals and DIN locating.

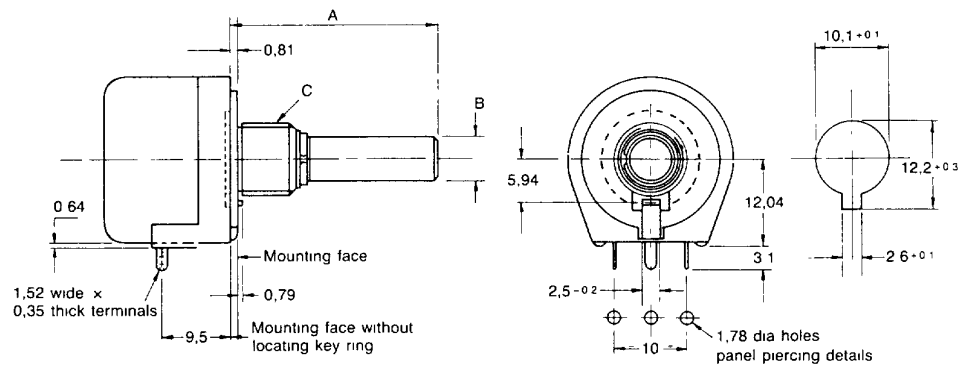

Type ABW1P Printed circuit terminals, preset, no bush.

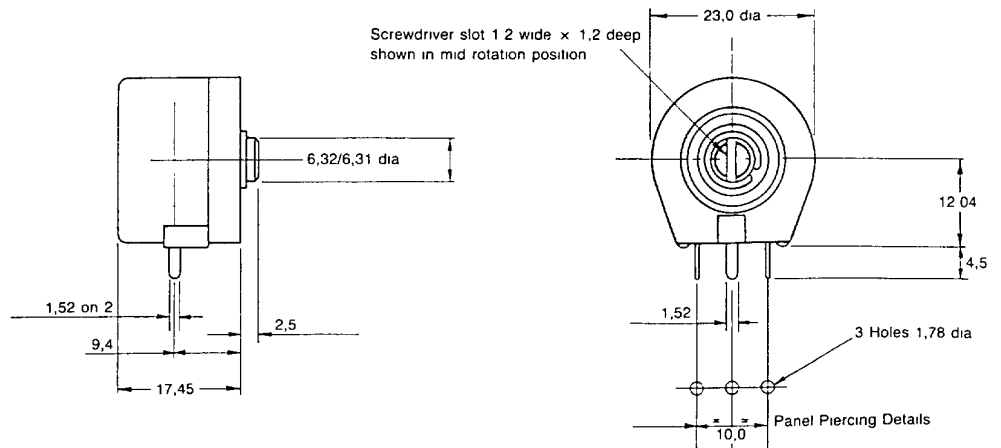
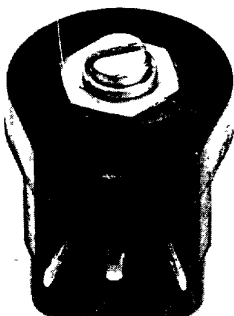

Series ABW2 wirewound Potentiometer

The proven ABW2 Series of Potentiometers are of rugged construction and suitable for use in professional and industrial electronic equipment. The method of manufacture ensures good element linearity and the ability to achieve close resistance tolerance. The range contains a very wide variety of features, the more commonly specified are detailed in table 1.

Electrical specification

Effective Rotation

270° ± 5° without switch 240° ± 5° with switch

Resistance Range

1Ω — 50kΩ

Resistance Tolerance

Standard ± 10%

Special: ± 5%, ± 2%, ± 1% (Values >47Ω)

Laws

Linear, Non-linear

Non-linear functions are achieved by former profiling or by using up to three linear sections of varying resistance gradients

Linearity

Standard: Independent 2%

Special: 1%

Voltage Rating

300V a.c./d.c. maximum

Resolution

Can be determined from Resolution v Resistance graph If degree of resolution is a particular requirement customer should state this in specification

Power Rating at 40°C Ambient Temperature

Linear 2 Watts

Non-linear: Dependent on exponent of the law

E.N.R.

Not greater than 100Ω

Voltage Proof

1 kV a.c. minimum

Insulation Resistance

>1000MΩ at 500V d.c.

Terminal Resistance

Not greater than 0.01% of nominal resistance or 0.2Ω whichever is the greater

Hop On Resistance

Not greater than 3% of total nominal resistance.

Taps

Single tap available at 50% effective rotation.

Mains Switch

Each control is fitted with a double pole, single throw mains switch or a single pole changeover switch, operating in 30° rotation of the control spindle. In the standard construction, the switch is OFF in the fully anti-clockwise position of the spindle but other switch/positional arrangements can be provided The switch is rated at 2 Amps/250V a.c. with a surge rating of 64 Amp.

Clearance and creepage distances conform to BS.415 Approvals to SEMKO, DEMKO, NEMKO, CSA

Mechanical specification

Mechanical Rotation

300° ± 5°

Operating Torque

Standard: 0,7 — 3,6 Ncm

Mounting Details

Standard Bush: Bush 9,5mm diameter, 32 TPI Whitworth form (BS 84) medium fit, 6,3mm or 9,5mm long Standard locating key left of centre (terminals down viewed from spindle end) fits into 3,2mm hole on 13,5mm radius Each control is supplied with a fixing nut and internal toothed lockwasher

Metric Bush: M10 × 0,75mm dia 8mm long. Panel and spindle sealing available to R.C.L. 224. Split bush and jam nut construction can be supplied to provide spindle locking facilities. (Imperial standard only)

End Stop Torque

113 Ncm

Spindles

Diameter. 6,3mm

Standard lengths: 12,7mm, 15,9mm, 19mm, 25,4mm

Round with screwdriver slot.

Other lengths and end configuration to customers' requirements.

Insulated spindles: Controls can be supplied with operating ends of high grade insulating material Diameters suitable for continental mounting standards can be supplied.

Terminals

Standard Solder lug

Special Gold washed centre terminal

Resolution and Temperature Coefficient v Resistance Value (Typical)

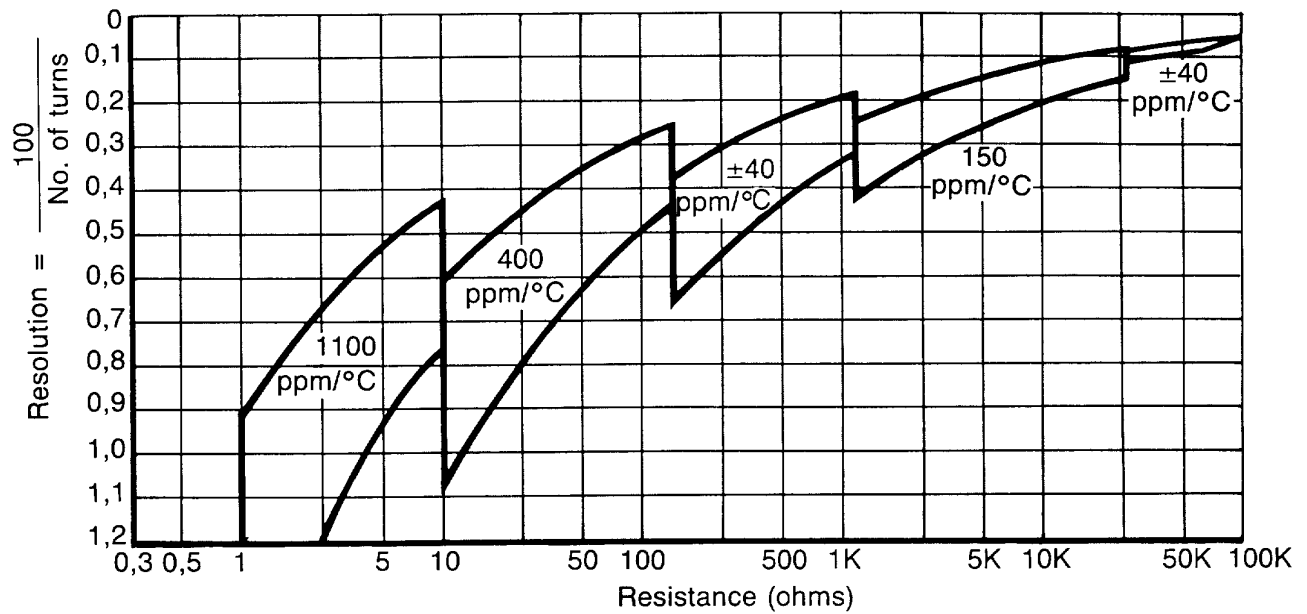

OPERATING CURVE

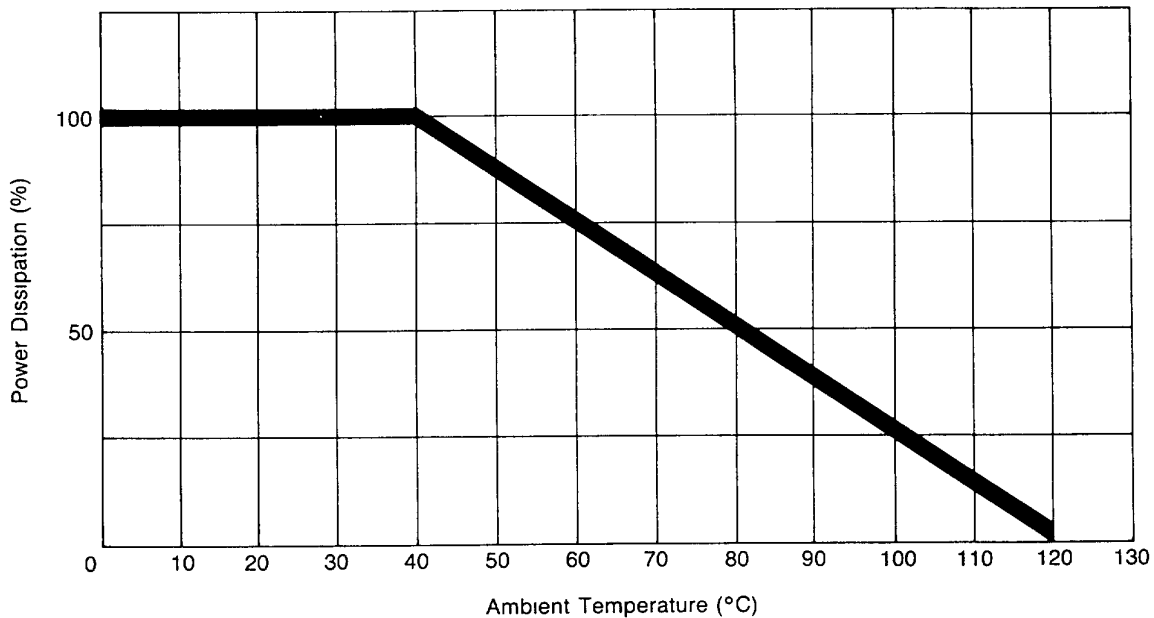
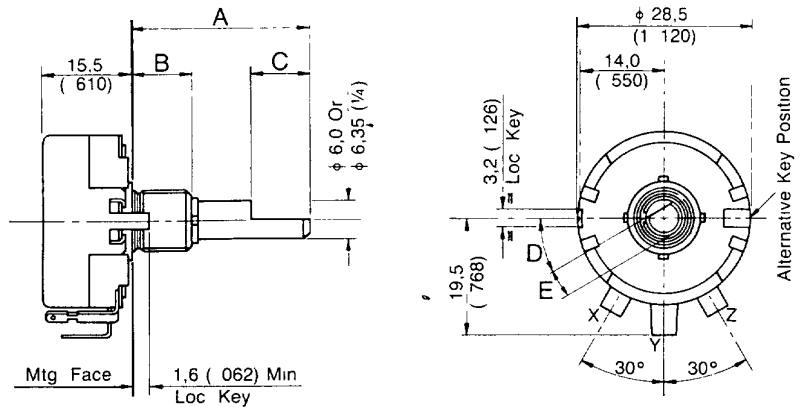
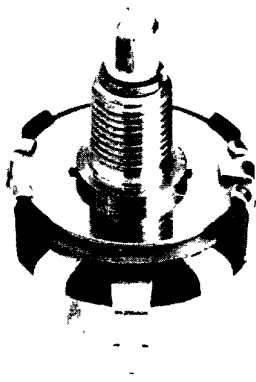

Table 1

Type	Description
ABW2	Basic Single Potentiometer. Solder terminals.
AR-ABW2	Single Potentiometer with Mains Switch. Solder terminals.
F-ABW2	Single Potentiometer with Forward Facing PC Mounting.
ABW2-B	Single Potentiometer with Dual Wiper, for use as Audio Fader.
ABW2-V	Single Potentiometer with spindle insulated for use up to 10kV.
2-ABW2	Double ganged Potentiometer.
C2-ABW2	Dual Potentiometer independently operable through concentric spindles.
AR-2-ABW2	Double ganged Potentiometer with Mains Switch.
AR-C2-ABW2	Dual Potentiometer independently operable through concentric spindles with Mains Switch.

Type ABW2 Single Potentiometer



Type AR-ABW2 Single Potentiometer with Mains Switch

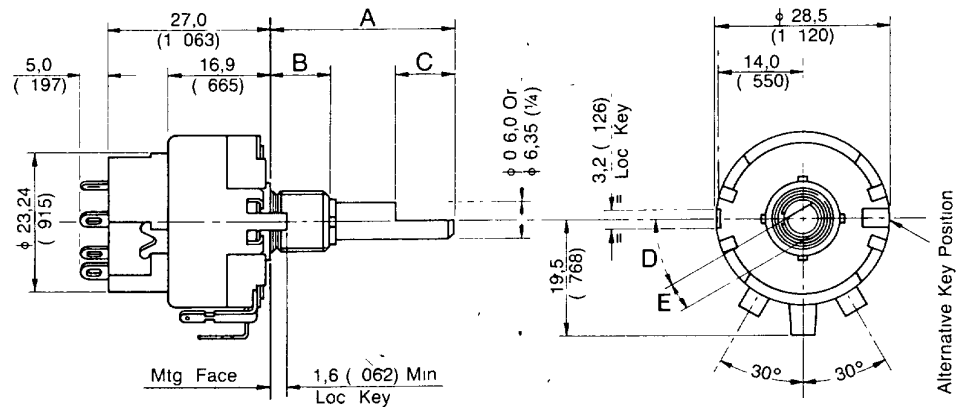
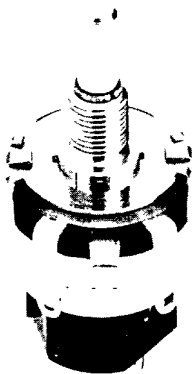

Type F-ABW2 Single Potentiometer with Forward Facing PC terminals

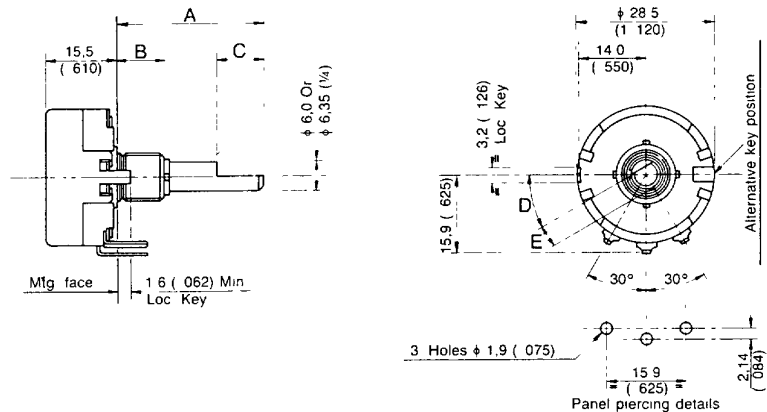
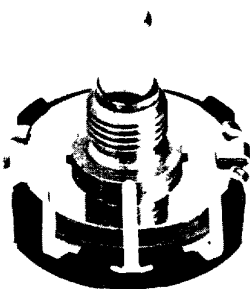

Type ABW2-B Audio Fader

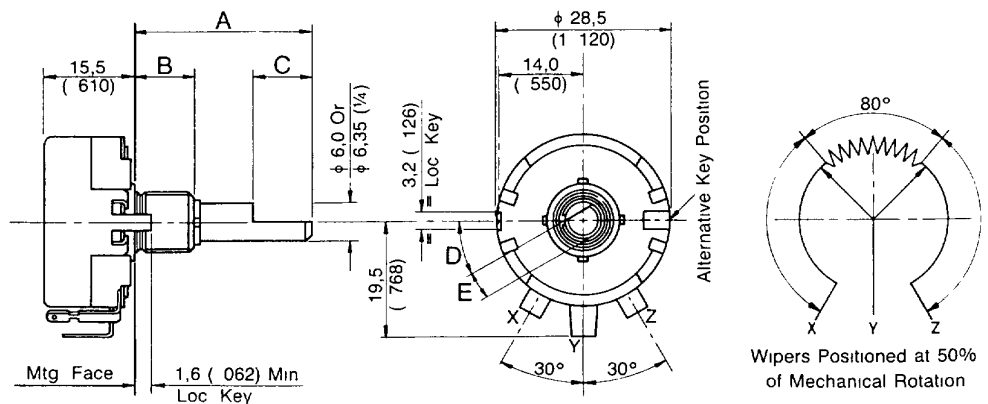
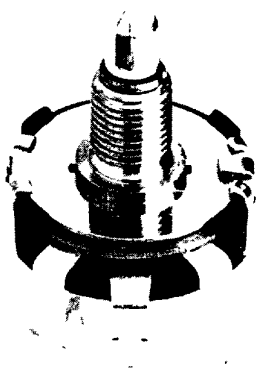

Type 2-ABW2 Dual Ganged Potentiometer

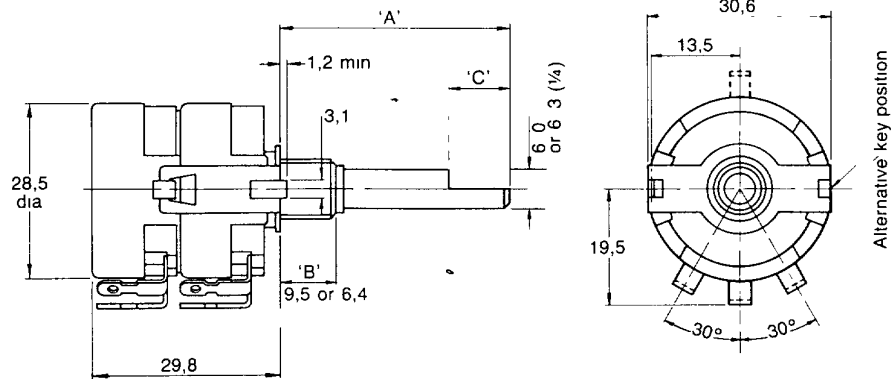
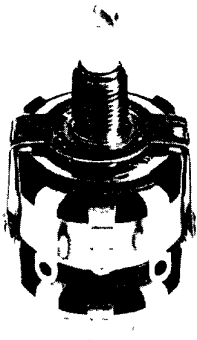

Type AR-2-ABW2 Dual Ganged Potentiometer with Mains Switch

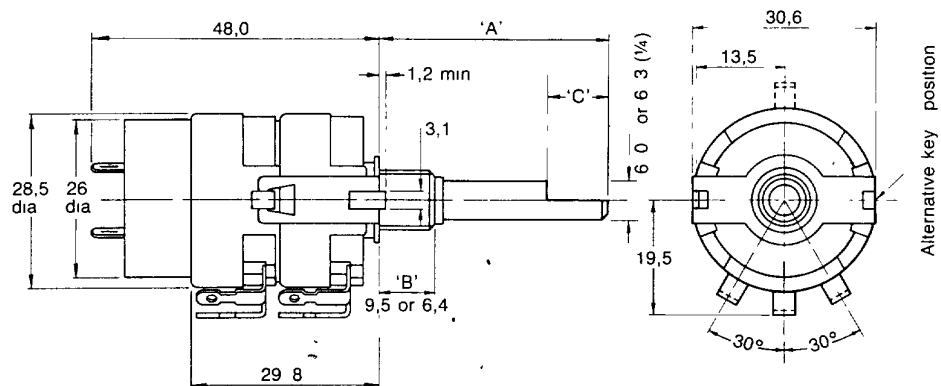
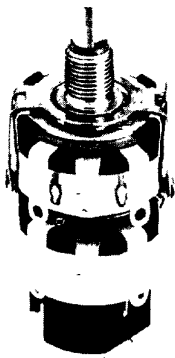

Type C2-ABW2 Dual Concentric Potentiometer

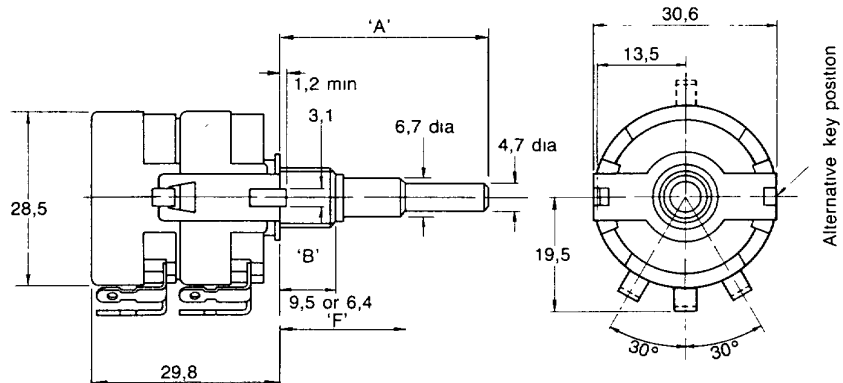

Type AR-C2-ABW2 Dual Concentric Potentiometer with Mains Switch

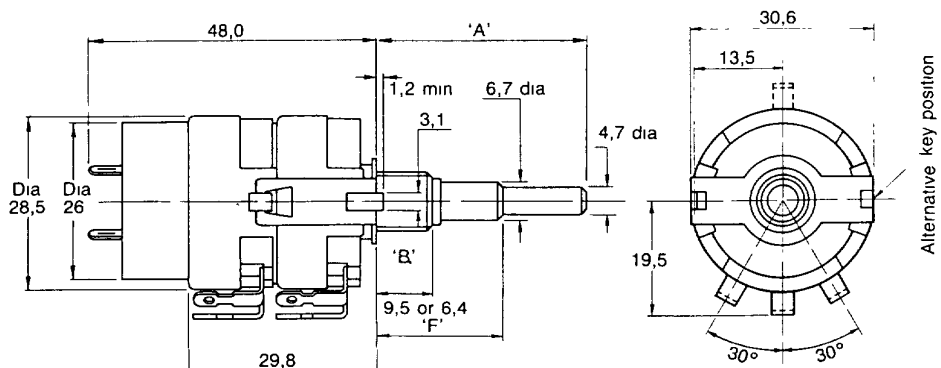
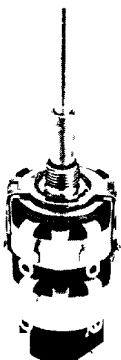

Key to Details: A. Shaft length to specification, B. Bush thread length Imperial 9,5 or 6,35mm, Metric 8mm, C. Flat length to specification, D. Angle of Flat to specification, E. Specify position of flat with shaft in fully anti-clockwise position when viewed from knob end, F. Flat thickness to specification

Series ABW3 wirewound Potentiometer

The proven ABW3 Series of 3 Watt wirewound Potentiometers has a high reputation for reliability and long life. The high degree of concentricity between wiper and element and the consistency of winding confers a linearity better than 2%. The range includes a variety of T and L attenuators.

Electrical specification

Effective Rotation

280° ± 5° without switch, 250° ± 5° with switch.

Resistance Range

Standard: 1Ω to 50KΩ

Special: Over 50KΩ to 100KΩ

Resistance Tolerance

Standard: ± 10%

Special ± 5%, ± 2%, ± 1% (Values >47Ω)

Laws

Linear, Non-linear

Non-linear functions are achieved by former profiling or by using up to three linear sections of varying resistance gradients.

Linearity

Standard: Independent 2%

Special: 1%

Voltage Rating

300V a.c / d.c maximum

Resolution

Can be determined from Resolution v Resistance graph. If degree of resolution is a particular requirement customer should state this in specification.

Power Rating at 40°C Ambient Temperature

Linear: 3 Watts

Non-linear: Dependent on exponent of the law.

E.N.R.

Not greater than 100Ω.

Voltage Proof

1 kV a.c. minimum

Insulation Resistance

>1000MΩ at 500V d.c.

Terminal Resistance

Not greater than 0.01% of nominal resistance or 0.2Ω whichever is the greater

Hop On Resistance

Not greater than 3% of total nominal resistance

Mains Switch

Double pole, single throw mains switch or single pole changeover switch, operating in 30° rotation of the control spindle. In the standard construction, the switch is OFF in the fully anti-clockwise position of the spindle but other switch positional arrangements can be provided. The switch is rated at 2 Amps/250V a.c. with a surge rating of 64 Amps.

Clearance and creepage distances conform to BS 415. Approvals to SEMKO, DEMKO, NEMKO, CSA

Mechanical specification

Mechanical Rotation

300° ± 5°

Operating Torque

Standard: 0,7 – 3,6 Ncm

Mounting Details

Standard Bush. Bush 9,5mm diameter, 32 TPI Whitworth form (BS 84) medium fit, 6,3mm or 9,5mm long. Flat metal locating key available at 12,7mm radius. Each control is supplied with a fixing nut and internal toothed lockwasher

Panel and spindle sealing available to R.C.L.224 Split bush and jam nut construction can be supplied to provide spindle locking facilities. (Imperial standard only)

End Stop Torque

113 Ncm

Spindles

Diameter 6,3mm

Standard lengths: 12,7mm, 15,9mm, 19mm, 25,4mm

Round with screwdriver slot

Other lengths and end configuration to customers' requirements

Insulated spindles: Controls can be supplied with operating ends of high grade insulating material.

Terminals

Standard: Solder lug

Special: Gold washed centre terminal

Resolution and Temperature Coefficient v Resistance Value (Typical)

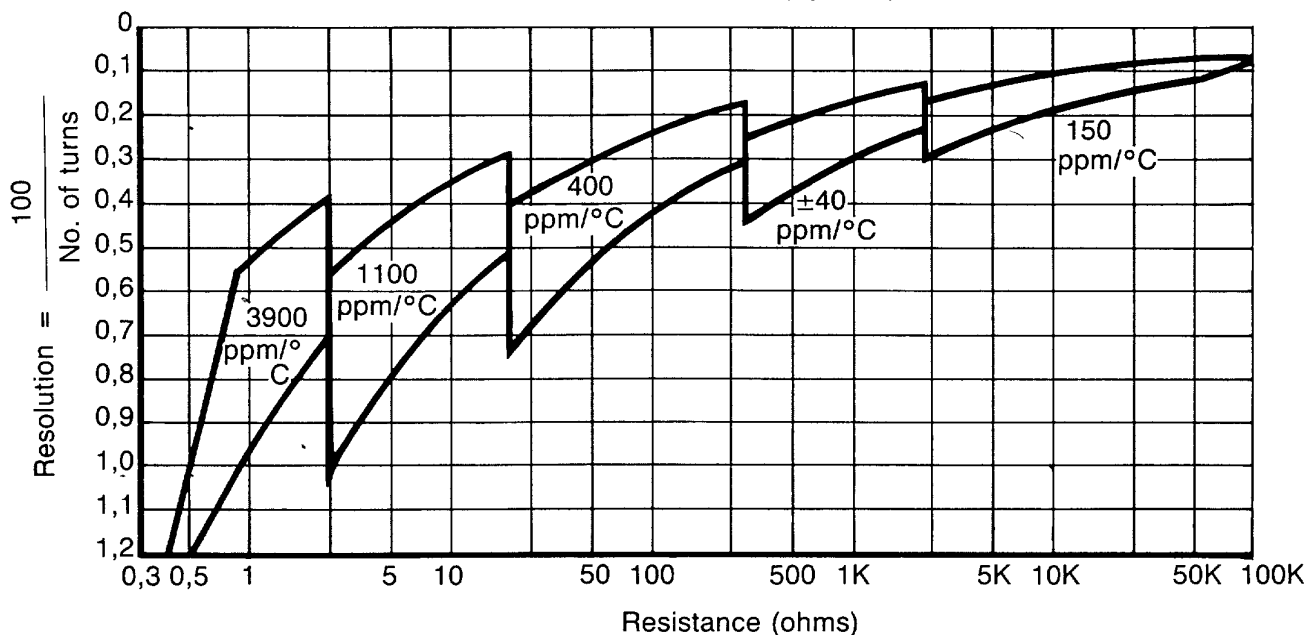

DERATING CURVE

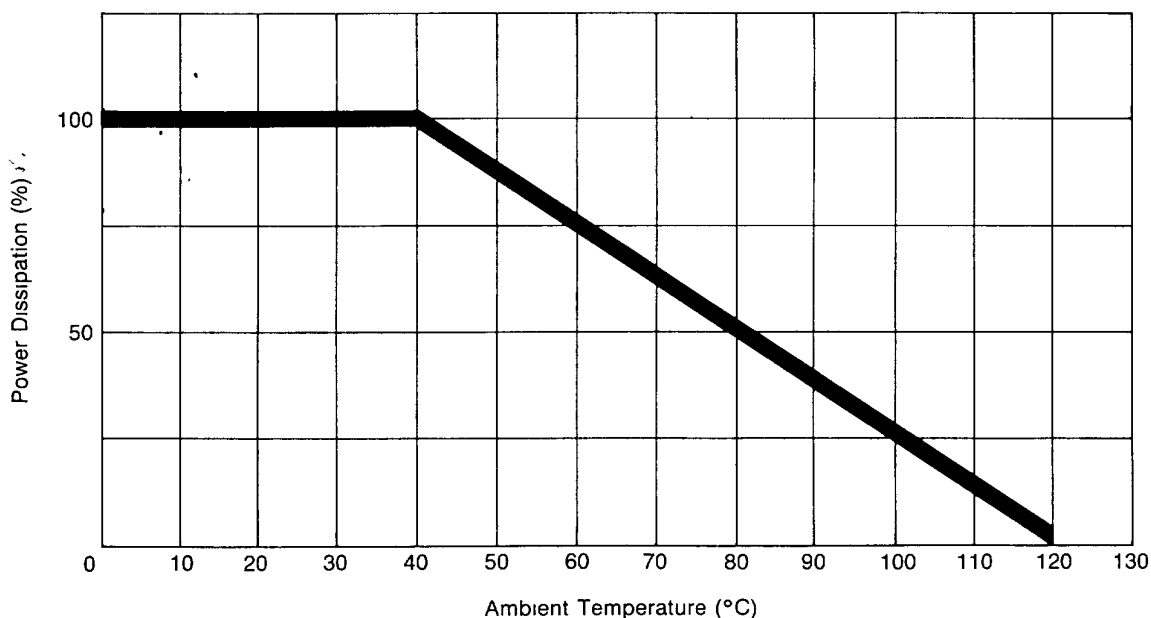
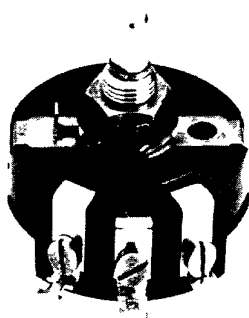

Table 1

Type	Description
ABW3	Basic Single Potentiometer. Solder terminals.
AR-ABW3	Single Potentiometer with Mains Switch.
2-ABW3	Double Ganged Potentiometer.
AR-2-ABW3	Double Ganged Potentiometer with Mains Switch.
C2-ABW3	Dual Potentiometer independently operable through concentric spindles.
AR-C2-ABW3	Dual Potentiometer independently operable through concentric spindles with Mains Switch.
C1L-ABW3	Double Ganged Potentiometer connected as constant Impedance L Pad Attenuator.
C1T-ABW3	Triple Ganged Potentiometer connected as constant Impedance T Pad Attenuator.

Type ABW3 Single Potentiometer



Dimensions in millimetres

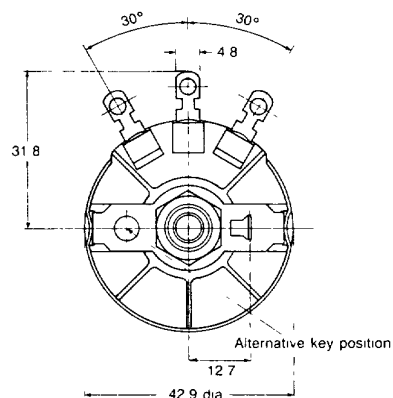
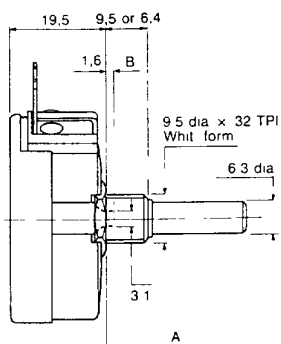

Type AR-ABW3 Single Potentiometer with Mains Switch

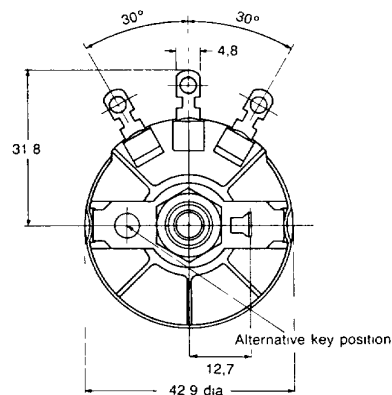
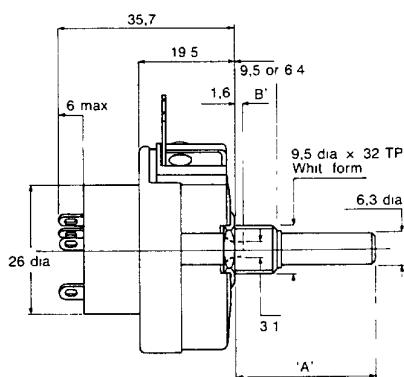
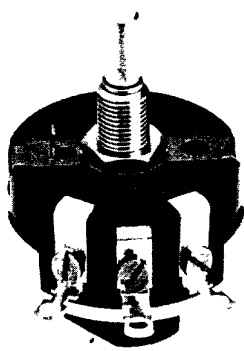

Type 2-ABW3 Dual Ganged Potentiometer

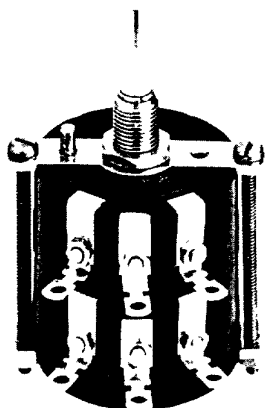

Dimensions in millimetres

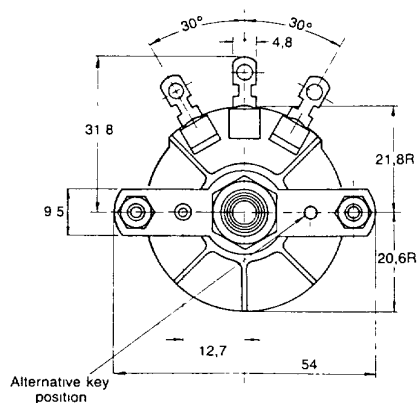
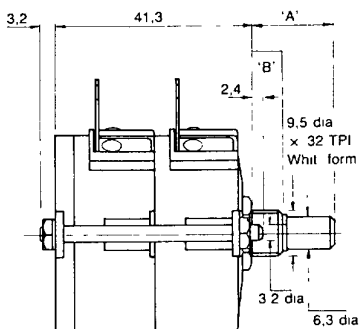

Type C2-ABW3 Dual Concentric Potentiometer

(Panel unit operated by outer spindle, rear unit operated by inner spindle)

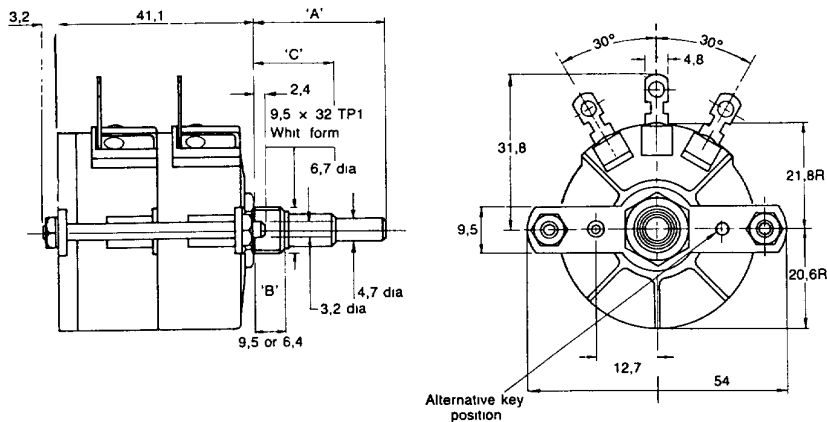

Type C1L-ABW3 Dual Ganged Potentiometer connected as Constant Impedance 'L' Pad

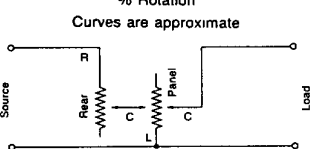
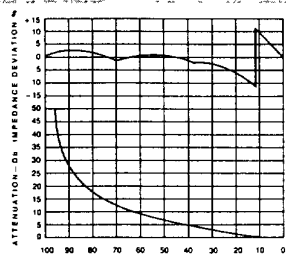

Constant Impedance
Constant impedance to the source is substantially maintained throughout the entire rotation of the L pad control. The control may, of course, be wired to present a constant impedance to either source or load, but not both.

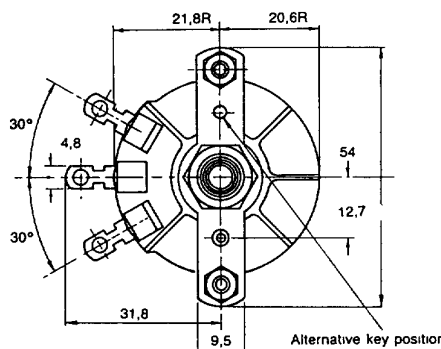
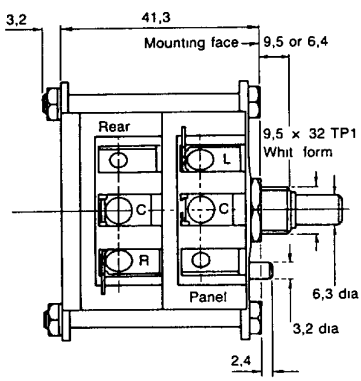

Multiple Speaker Controls
Several loudspeakers operated from a single source may be individually controlled by using several L pads without affecting the source load

Terminal Connections
For constant impedance to the source, Series C1L-ABW 3 L pads should be connected as indicated on wiring detail.

Terminal Designation
Letters R, L and C refer to the right, left and centre terminals respectively, as illustrated.

Power Rating
The maximum safe d.c. power rating is 2.5 watts, though in audio applications these controls have been successfully used up to 10 watts.

Type C1T-ABW3 Triple Ganged Potentiometer connected as Constant Impedance 'T' Pad

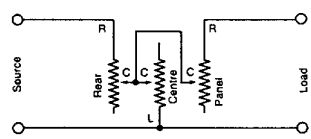
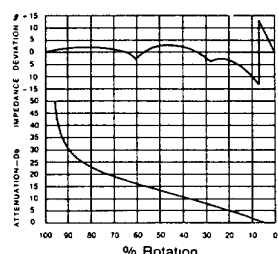

Constant Impedance
Both input and output impedances of Series C1T-ABW 3 T-pads are substantially constant throughout the entire range

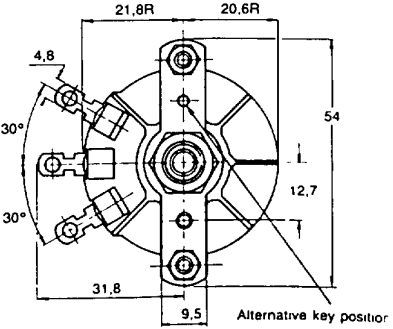
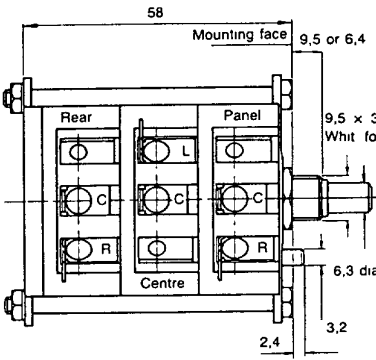

Terminal Connections
C1T-ABW 3 T-pads are connected as shown in wiring detail.

Terminal Designation
Letters R, L and C refer to right, left and centre terminals respectively, as illustrated

Power rating
The maximum safe d.c. power rating is 2.5 watts, though in audio applications these controls have been successfully used up to 10 watts