

46.02 mm Diameter 15 Turn Dial



FEATURES

- Round vernier scale
- 1 13/16" dia.
- 1/4" or 1/8" or 6 mm metric bore shaft adapter
- Satin chrome finish with black markings
- Black chrome finish with white markings
- Brushed chrome finish with black markings



MECHANICAL SPECIFICATIONS	
PARAMETER	
Mounting	Direct to shaft with # 4 - 40 hex socket set screw located adjacent to No.75 on graduated dial.
Numeral Size: Counter Wheel: Graduated Dial:	0.90 H x 0.013" W (2.29 x 0.33 cm) 0.109 x 0.018" (2.77 x 0.46 cm)
Graduation Size: Numerals and Every Fifth	0.55" L (1.40 cm)
Intermediate Width	0.035" L (0.89 cm) 0.012" (0.30 cm)
Weight	3.0 max. (85.05)

OPERATIONAL SPECIFICATIONS	
Readout and Operation	1499 turns total The number in window (0 thru 14) indicates completed number of turns of the drive sleeve. Graduated circular dial indicates the percent of the partial turn of the drive sleeve
Transfer Point	The number in center of window shall change as graduated dial rotates between 94 and 0
Rotation	Readout shall increase with clockwise and decrease with counterclockwise rotation
Accuracy	Zero backlash between graduated dial and the drive sleeve

DIMENSIONS in inches (millimeters)

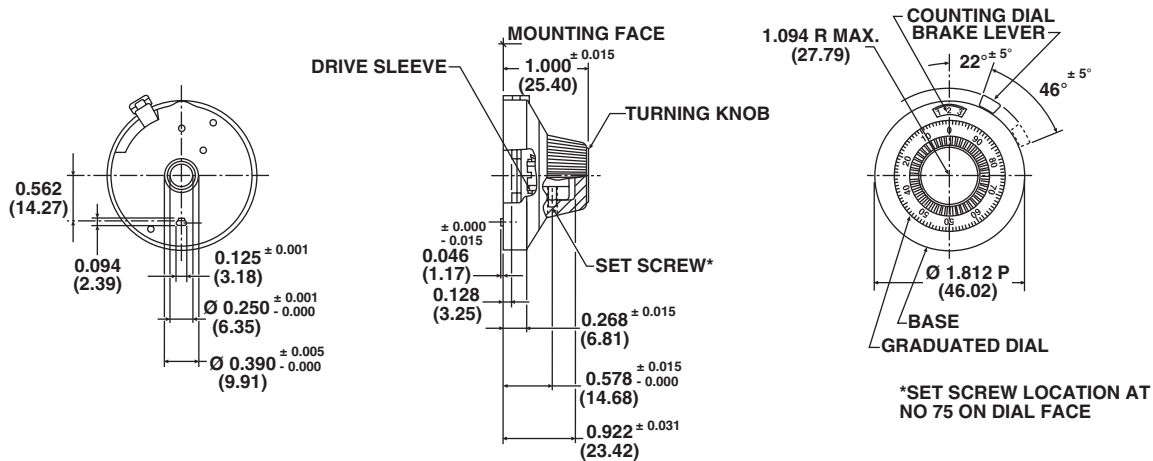

ORDERING INFORMATION/DESCRIPTION				
21	A	11	B010	e
MODEL	SHAFT DIAMETER AND ACCOMODATION	FINISH AND OTHER FEATURES	PACKAGING	LEAD FINISH
	A 1/4" Shaft (standard) B 6 mm metric bore shaft adapter C 1/8" Shaft adapter	11. Satin chrome, black markings 21. Black chrome, white markings 31. Brushed chrome, black markings		

Example: 21 - A - 11

SAP PART NUMBERING GUIDELINES			
21	A	11	B10
MODEL	SHAFT DIAMETER	FINISH	PACKAGING



Disclaimer

All product specifications and data are subject to change without notice.

Vishay Intertechnology, Inc., its affiliates, agents, and employees, and all persons acting on its or their behalf (collectively, "Vishay"), disclaim any and all liability for any errors, inaccuracies or incompleteness contained herein or in any other disclosure relating to any product.

Vishay disclaims any and all liability arising out of the use or application of any product described herein or of any information provided herein to the maximum extent permitted by law. The product specifications do not expand or otherwise modify Vishay's terms and conditions of purchase, including but not limited to the warranty expressed therein, which apply to these products.

No license, express or implied, by estoppel or otherwise, to any intellectual property rights is granted by this document or by any conduct of Vishay.

The products shown herein are not designed for use in medical, life-saving, or life-sustaining applications unless otherwise expressly indicated. Customers using or selling Vishay products not expressly indicated for use in such applications do so entirely at their own risk and agree to fully indemnify Vishay for any damages arising or resulting from such use or sale. Please contact authorized Vishay personnel to obtain written terms and conditions regarding products designed for such applications.

Product names and markings noted herein may be trademarks of their respective owners.