

High Current Inductor High Temperature Series



Manufactured under one or more of the following:
US Patents; 6,198,375/6,204,744/6,449,829/6,460,244.
 Several foreign patents, and other patents pending.

FEATURES

- Shielded construction
- Frequency range up to 1.0 MHz
- Handles high transient current spikes without saturation
- Ultra low buzz noise, due to composite construction
- Compliant to RoHS directive 2002/95/EC



**RoHS
COMPLIANT**
APPLICATIONS

- Desktop/server applications
- High current POL converters
- Line filters
- Motor control systems
- DC/DC converters in distributed power systems
- DC/DC converter for Field Programmable Gate Array (FPGA)

STANDARD ELECTRICAL SPECIFICATIONS				
L_0 INDUCTANCE (μH) $\pm 20\%$ AT 100 kHz, 0.25 V, 0 A	DCR m Ω TYP. 25 °C	DCR m Ω MAX. 25 °C	HEAT RATING CURRENT DC AMPS ³ TYP.	SATURATION CURRENT DC AMPS ⁴ TYP.
0.47	0.47	0.52	60.0	60.0
4.7	2.52	2.65	22.0	22.0
10	7.68	8.06	13.0	13.0
22	14.10	14.80	11.5	11.5
33	23.70	24.90	8.5	8.5
47	34.80	36.50	7.0	7.0
68	50.00	52.50	5.8	5.8
100	68.30	71.70	5.0	5.0

Notes

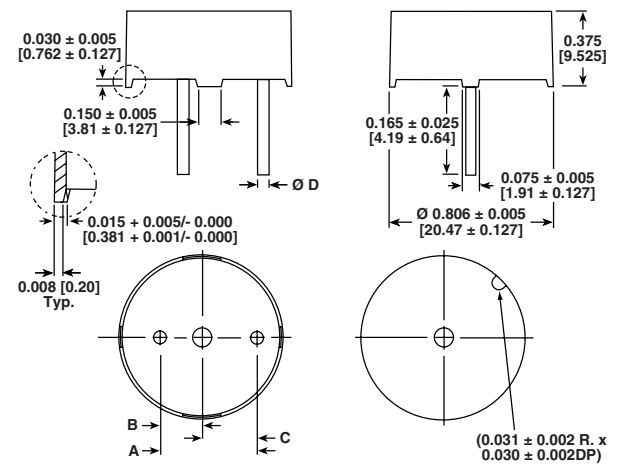
- (1) All test data is referenced to 25 °C ambient
- (2) Operating temperature range - 55 °C to + 155 °C
- (3) DC current (A) that will cause an approximate ΔT of 40 °C
- (4) DC current (A) that will cause L_0 to drop approximately 20 %
- (5) The part temperature (ambient + temp. rise) should not exceed 155 °C under worst case operating conditions. Circuit design, component placement, PWB trace size and thickness, airflow and other cooling provisions all affect the part temperature. Part temperature should be verified in the end application.

DIMENSIONS in inches [millimeters]

VALUE	A MAX.	B MAX.	C MAX.	D MAX.
0.47 μH	0.351 [8.915]	0.133 [3.378]	0.218 [5.537]	0.083 [2.108]
4.7 μH	0.464 [11.786]	0.198 [5.029]	0.266 [6.756]	0.066 [1.676]
10 μH	0.427 [10.846]	0.132 [3.353]	0.295 [7.493]	0.052 [1.321]
22 μH	0.450 [11.430]	0.152 [3.861]	0.298 [7.569]	0.047 [1.194]
33 μH	0.477 [12.116]	0.180 [4.572]	0.297 [7.544]	0.037 [0.940]
47 μH	0.525 [13.335]	0.204 [5.182]	0.321 [8.153]	0.033 [0.838]
68 μH	0.498 [12.649]	0.196 [4.978]	0.301 [7.645]	0.033 [0.838]
100 μH	0.479 [12.167]	0.152 [3.861]	0.327 [8.306]	0.030 [0.762]

DESCRIPTION

IHTH-0750JZ-5A	4.7 μH	$\pm 20\%$
MODEL	INDUCTANCE VALUE	INDUCTANCE TOLERANCE

GLOBAL PART NUMBER

I	H	T	H	0	7	5	0	J	Z	E	B	4	R	7	M	5	A
MODEL				SIZE				PACKAGE CODE		INDUCTANCE VALUE		INDUCT. TOL.		SERIES			



PERFORMANCE GRAPHS

