

High-current version
Size 2220 (EIA) or 5650 (IEC)
Rated inductance 1 to 10000 μ H
Rated current 35 to 2500 mA



Construction

- Upright ferrite drum core
- Laser-welded winding
- Flame-retardant encapsulation

Features

- Very high current handling capability
- High L values
- Suitable for reflow (IR and vapor phase) and wave soldering

Applications

- Filtering of supply voltages, coupling, decoupling
- DC/DC converters
- Automotive electronics
- Telecommunications

Terminals

- Tinned
- 0,4 μ m Cu; 1–2 μ m Ag; 5–7 μ m Sn
- Base material CuSn6
- No leaching during wave soldering

Marking

Marking on component:

Manufacturer,

L value (in nH) and tolerance of L value (coded),
date of manufacture (coded)

Minimum data on reel:

Manufacturer, part number, ordering code,

L value and tolerance of L value,
quantity, date of packing

Delivery mode

12-mm blister tape, wound on 330-mm \varnothing reel

For details on taping, packing and packing units [see page 153](#)

General technical data

Rated inductance L_R	Measured with impedance analyzer HP 4194A at frequency f_L
Q factor Q_{\min}	Measured with impedance analyzer HP 4194A at frequency f_Q
Rated current I_R	Maximum permissible dc with inductance decrease $\Delta L/L_0 \leq 10\%$ and temperature increase of $\leq 40\text{ K}$ at rated temperature of 85°C
Self-resonance frequency $f_{\text{res, min}}$	Measured with network analyzer HP 8753
DC resistance R_{max}	Measured at 20°C ambient temperature, measuring current $< I_R$
Climatic category	In accordance with IEC 60068-1 55/125/56 ($-55^\circ\text{C}/+125^\circ\text{C}/56$ days damp heat test)
Solderability	In accordance with IEC 60062-2-58 (215 ± 3) $^\circ\text{C}$, ($3 \pm 0,3$) s Wetting of soldering area: $\geq 90\%$
Resistance to soldering heat	In accordance with IEC 60068-2-20 260°C , 10 s $\Delta L/L \leq \pm 3\%$
Permissible PCB bending	2 mm (100 mm long standard PCB)
Weight	Approx. 400 mg

Dimensional drawing

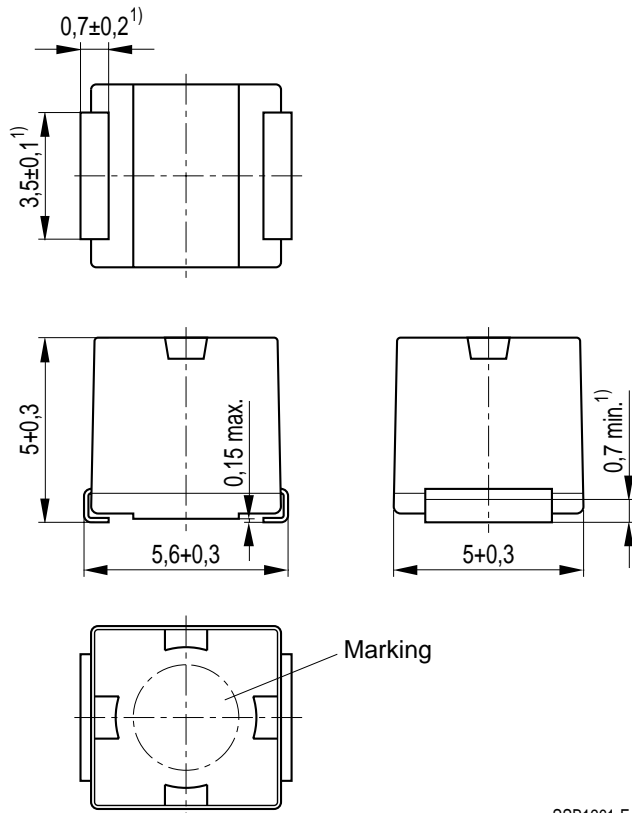

SSB1261-E

Layout recommendation

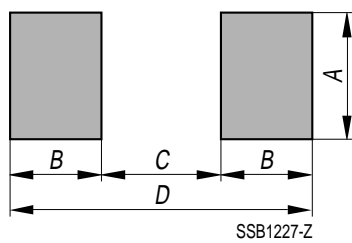

SSB1227-Z

Dimensions (mm)	A	B	C	D
Wave/reflow soldering	4,5	2,0	4,0	8,0

1) Soldering area, tinned

Characteristics and ordering codes

L_R μH	Tolerance	Q_{min}	$f_L; f_Q$ MHz	I_R mA	R_{max} Ω	$f_{res, min}$ MHz	Ordering code ¹⁾	
1,0	± 10 % ≙ K	10	7,96	2500	0,024	95	B82442-H1102-K	
1,2		10	7,96	2350	0,028	70	B82442-H1122-K	
1,5		10	7,96	2200	0,032	55	B82442-H1152-K	
1,8		10	7,96	2000	0,040	47	B82442-H1182-K	
2,2		10	7,96	1800	0,048	42	B82442-H1222-K	
2,7		10	7,96	1700	0,056	37	B82442-H1272-K	
3,3		10	7,96	1550	0,064	34	B82442-H1332-K	
3,9		10	7,96	1450	0,072	32	B82442-H1392-K	
4,7		10	7,96	1350	0,088	29	B82442-H1472-K	
5,6		10	7,96	1250	0,104	26	B82442-H1562-K	
6,8	10	7,96	1130	0,120	24	B82442-H1682-K		
8,2	10	7,96	1050	0,144	22	B82442-H1822-K		
10	± 5 % ≙ J	10	2,52	1000	0,168	19	B82442-H1103-K	
12		10	2,52	880	0,20	17	B82442-H1123-K	
15		10	2,52	810	0,24	16	B82442-H1153-K	
18		10	2,52	740	0,29	14	B82442-H1183-K	
22		10	2,52	670	0,35	13	B82442-H1223-K	
27		10	2,52	620	0,42	11,5	B82442-H1273-K	
33		± 10 % ≙ K	10	2,52	560	0,50	10,5	B82442-H1333-+
39			10	2,52	520	0,58	9,5	B82442-H1393-+
47			10	2,52	480	0,68	8,5	B82442-H1473-+
56		± 10 % ≙ K	10	2,52	430	0,80	7,8	B82442-H1563-+
68	10		2,52	400	0,96	7,0	B82442-H1683-+	
82	10		2,52	380	1,12	6,4	B82442-H1823-+	
100	± 10 % ≙ K	20	0,796	350	1,28	6,0	B82442-H1104-+	
120		20	0,796	320	1,52	5,4	B82442-H1124-+	
150		20	0,796	290	1,76	4,8	B82442-H1154-+	
180		20	0,796	270	2,24	4,4	B82442-H1184-+	
220		20	0,796	240	2,72	3,9	B82442-H1224-+	
270		20	0,796	220	3,36	3,6	B82442-H1274-+	

1) Replace the + by the code letter for the required inductance tolerance (see table).

Characteristics and ordering codes (continued)

L_R μH	Tolerance	Q_{\min}	$f_L; f_Q$ MHz	I_R mA	R_{\max} Ω	$f_{\text{res, min}}$ MHz	Ordering code ¹⁾
330	$\pm 5\%$	20	0,796	200	3,92	3,2	B82442-H1334-+
390	$\triangleq J$	20	0,796	180	4,64	2,9	B82442-H1394-+
470	$\pm 10\%$	20	0,796	170	5,60	2,6	B82442-H1474-+
560	$\triangleq K$	20	0,796	150	6,80	2,4	B82442-H1564-+
680		20	0,796	140	8,00	2,2	B82442-H1684-+
820		20	0,796	130	10,4	2,0	B82442-H1824-+
1000		30	0,252	120	12,0	1,8	B82442-H1105-+
1200		30	0,252	105	13,6	1,5	B82442-H1125-+
1500		30	0,252	100	16,0	1,4	B82442-H1155-+
1800		30	0,252	85	24,0	1,3	B82442-H1185-+
2200		30	0,252	75	28,0	1,2	B82442-H1225-+
2700		30	0,252	65	44,0	1,1	B82442-H1275-+
3300		30	0,252	55	48,0	1,0	B82442-H1335-+
3900		30	0,252	53	56,0	1,0	B82442-H1395-+
4700		30	0,252	50	62,4	0,9	B82442-H1475-+
5600		30	0,252	46	68,0	0,8	B82442-H1565-+
6800		30	0,252	42	88,0	0,7	B82442-H1685-+
8200		30	0,252	39	100	0,6	B82442-H1825-+
10000		30	0,0796	35	120	0,5	B82442-H1106-+

1) Replace the + by the code letter for the required inductance tolerance (see table).



Impedance $|Z|$
versus frequency f
measured with impedance analyzer
HP 4191A / HP 4194A

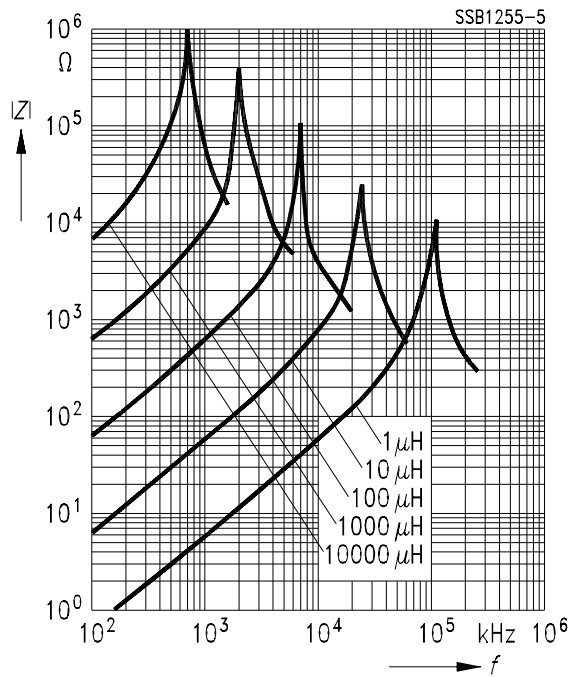

Inductance L
versus dc load current I_{DC}
measured with LCR meter
HP 4275A

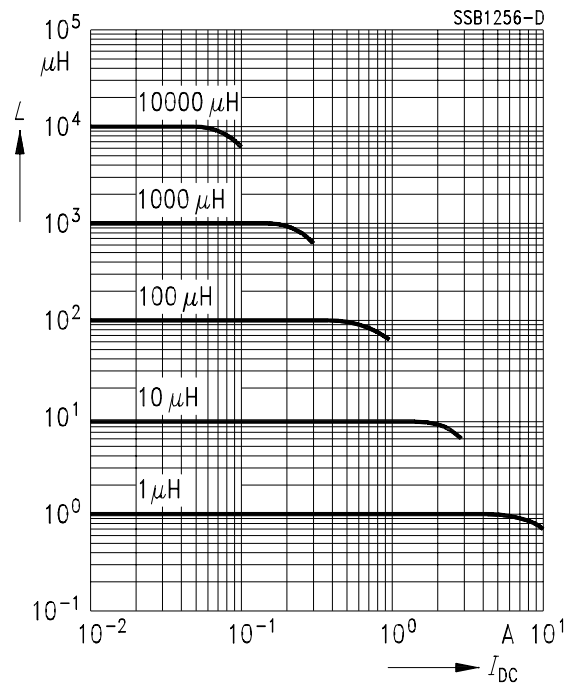

Q factor versus frequency f
measured with impedance analyzer
HP 4191A

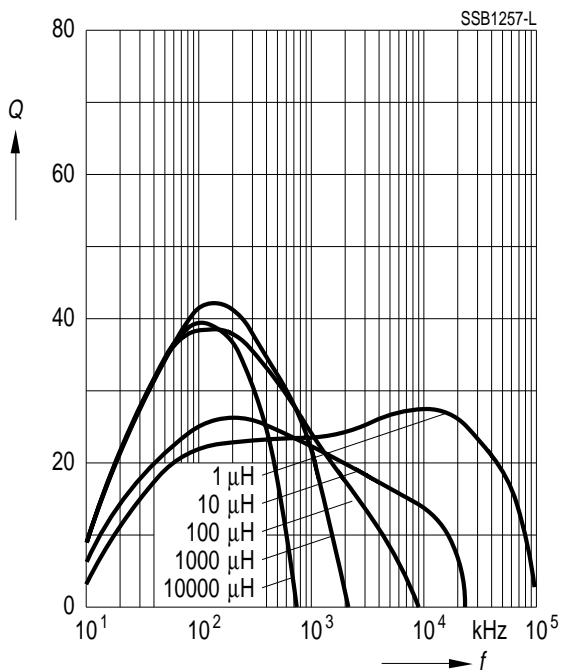

Current derating I_{op}/I_R
versus ambient temperature T_A

