

### Description

- Compact footprint for high density, high current/low voltage applications
- Foil technology that adds higher reliability factor over the traditional magnet wire used for higher frequency circuit designs
- Frequency Range up to 1MHz
- Ferrite core material

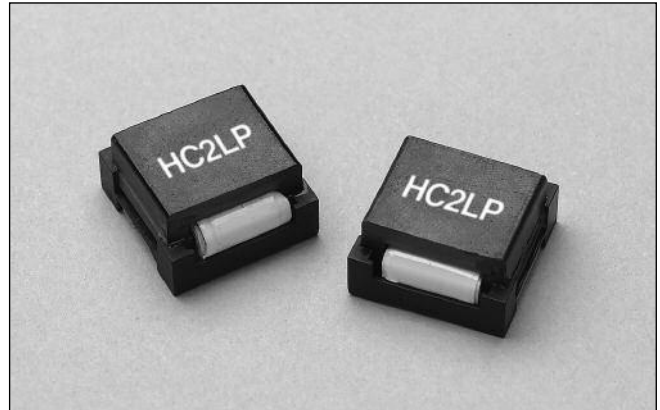

### Applications

- Next generation microprocessors
- Energy storage applications
- DC-DC converters
- Computers

### Environmental Data

- Storage temperature range: -40°C to +125°C
- Operating ambient temperature range: -40°C to +85°C (range is application specific).
- Solder reflow temperature: +260°C max. for 10 seconds max.

### Packaging

- Supplied in tape and reel packaging, 44mm width, 130 parts per 13" reel
- 45 parts per tray, bulk packaging also available

Part Number	Rated Inductance $\mu\text{H}$	OCL (1) $\mu\text{H} \pm 20\%$	I <sub>rms</sub> (2) Amperes (Typ.)	I <sub>sat</sub> (3) Amperes (Typ.)	DCR (4) Ohms (Max.)	Volts (5) $\mu\text{Sec}$
HC2LP-R47-R	.47	.52	52.9	63.75	.0006	6.87
HC2LP-R68-R	.68	.63	52.9	50.00	.0006	6.87
HC2LP-1R0-R	1.0	1.15	33.0	42.50	.0013	10.31
HC2LP-2R2-R	2.2	2.00	24.3	31.90	.0023	13.75
HC2LP-4R7-R	4.7	4.55	17.0	21.25	.0046	20.62
HC2LP-6R0-R	6.0	6.00	17.0	16.50	.0046	20.62

- 1) Open Circuit Inductance Test Parameters: 300kHz, 0.250 V<sub>rms</sub>, 0.0 Adc
- 2) DC current for an approximate temperature change of 40°C without core loss. Derating is necessary for AC currents. PCB layout, trace thickness and width, air-flow and proximity of other heat generating components will affect the temperature rise. It is recommended that the temperature of the part not exceed 125°C under

- 3) Peak current for approximately 30% roll-off
- 4) Values @ 20°C
- 5) Applied Volt-Time product (V- $\mu\text{s}$ ) across the inductor. This value represents the applied V- $\mu\text{s}$  at 300kHz necessary to generate a core loss equal to 10% of the total losses for 40°C temperature rise.

### Mechanical Diagrams

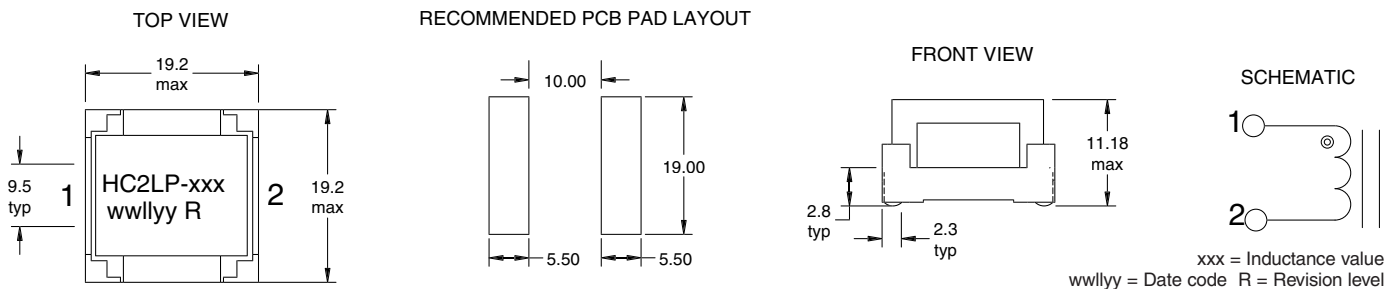

### Packaging Information

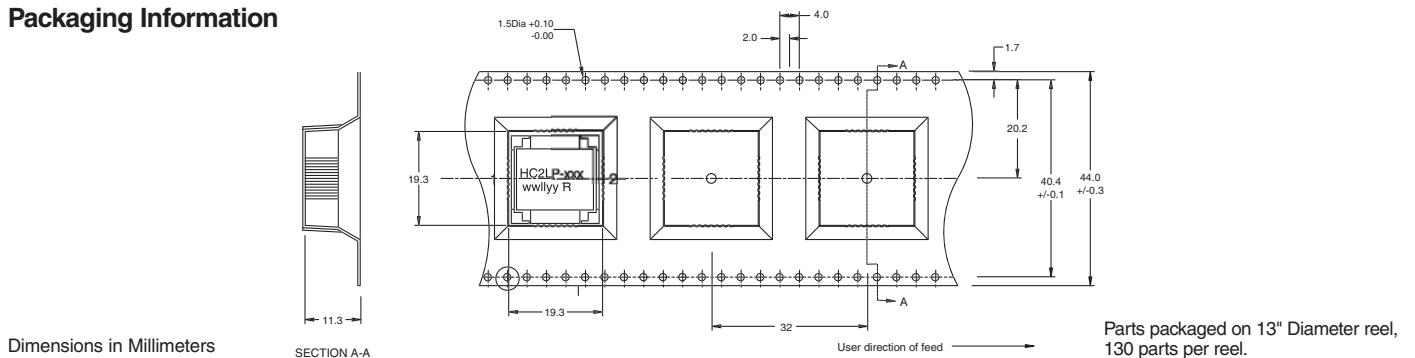

## Core Loss

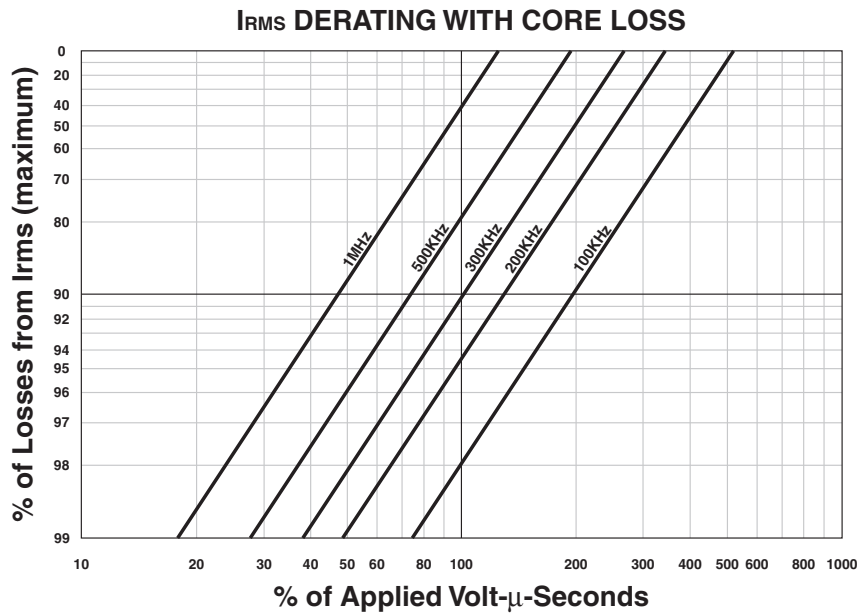

## Inductance Characteristics

