



ALL RIGHTS RESERVED. NO PORTION OF THIS PUBLICATION, WHETHER IN WHOLE OR IN PART CAN BE REPRODUCED WITHOUT THE EXPRESS WRITTEN CONSENT OF SPC TECHNOLOGY.

SPC-F005.DWG

REVISIONS

DOC. NO. SPC-F005 * Effective: 7/8/02 * DCP No: 1398

| DCP # | REV | DESCRIPTION | DRAWN | DATE | CHECKD | DATE | APPRVD | DATE |
|-------|-----|-------------|-------|----------|--------|--------|--------|--------|
| 1905 | A | RELEASED | EO | 05/13/06 | TL | 6/2/06 | HO | 6/2/06 |



RoHS Compliant

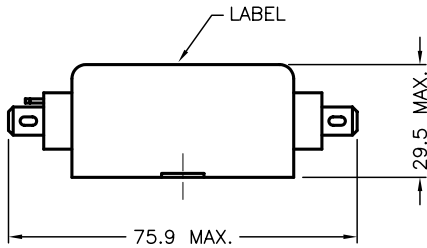
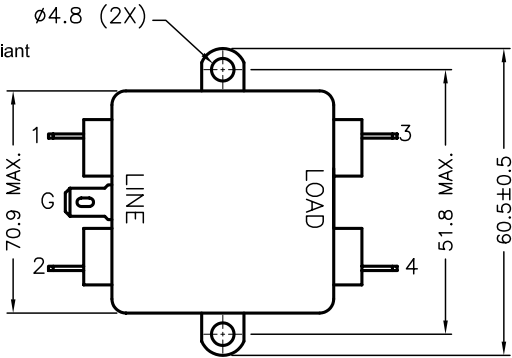

ELECTRICAL SCHEMATIC

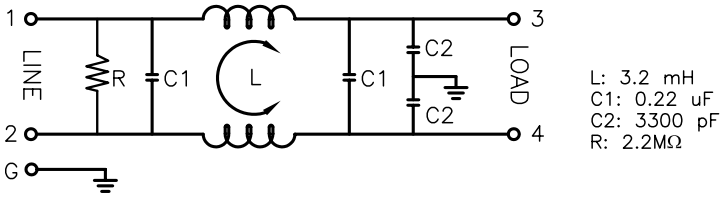

L: 3.2 mH
C1: 0.22 uF
C2: 3300 pF
R: 2.2MΩ

ELECTRICAL CHARACTERISTICS:

- VOLTAGE RATING: 115/250 VAC
- CURRENT RATING:
 - AT 115VAC: 3 A RMS MAX.
 - AT 250VAC: 3 A RMS MAX.
- OPERATING FREQUENCY: 50/60Hz
- LEAKAGE CURRENT: (EACH LINE TO GROUND)
 - AT 115VAC, 60Hz: 0.25 mA MAX.
 - AT 250VAC, 50Hz: 0.45 mA MAX.
- HIPOT RATING (FOR ONE MINUTE):
 - LINE TO GROUND: 2250 VDC
 - LINE TO LINE: 1450 VDC
- MINIMUM INSERTION LOSS IN dB:

| MHz | 0.01 | 0.05 | 0.10 | 0.15 | 0.50 | 1.0 | 5.0 | 10 | 30 |
|-----------|------|------|------|------|------|-----|-----|----|----|
| COM. MODE | - | - | - | 22 | 30 | 38 | 47 | 50 | 40 |
| DIF. MODE | - | - | - | 10 | 46 | 48 | 50 | 50 | 45 |

- AMBIENT TEMPERATURE: 40°C
- STORAGE/OPERATING TEMPERATURE: -25°C ~ +85°C
- SAFETY



DISCLAIMER:
ALL STATEMENTS AND TECHNICAL INFORMATION CONTAINED HEREIN ARE BASED UPON INFORMATION AND/OR TESTS WE BELIEVE TO BE ACCURATE AND RELIABLE. SINCE CONDITIONS OF USE ARE BEYOND OUR CONTROL, THE USER SHALL DETERMINE THE SUITABILITY OF THE PRODUCT FOR THE INTENDED USE AND ASSUME ALL RISK AND LIABILITY WHATSOEVER IN CONNECTION THEREWITH.

TOLERANCES:
UNLESS OTHERWISE SPECIFIED, DIMENSIONS ARE FOR REFERENCE PURPOSES ONLY.

| | |
|--------------|----------|
| DRAWN BY: | DATE: |
| EKLAS ODISH | 05/13/06 |
| CHECKED BY: | DATE: |
| THOMAS LEE | 6/2/06 |
| APPROVED BY: | DATE: |
| HISHAM ODISH | 6/2/06 |

| | | | |
|--|---------------------|-----------------|-----|
| DRAWING TITLE: EMI FILTER RoHS COMPLIANT | | | |
| SIZE | DWG. NO. | ELECTRONIC FILE | REV |
| A | SPC20195 | 83K9645.DWG | A |
| SCALE: NTS | U.O.M.: Millimeters | SHEET: 1 OF 1 | |