



ALL RIGHTS RESERVED. NO PORTION OF THIS PUBLICATION, WHETHER IN WHOLE OR IN PART CAN BE REPRODUCED WITHOUT THE EXPRESS WRITTEN CONSENT OF SPC TECHNOLOGY.

SPC-F005.DWG

REVISIONS

DOC. NO. SPC-F005 * Effective: 7/8/02 * DCP No: 1398

DCP #	REV	DESCRIPTION	DRAWN	DATE	CHECKD	DATE	APPRVD	DATE
1905	A	RELEASED	BY	05/13/06	TL	6/2/06	HO	6/2/06



RoHS Compliant

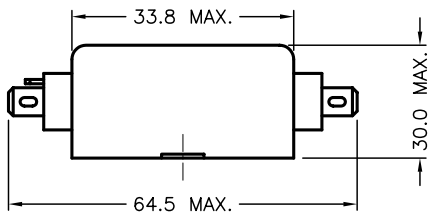
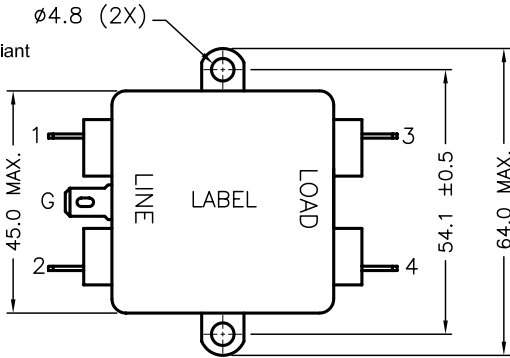

ELECTRICAL SCHEMATIC

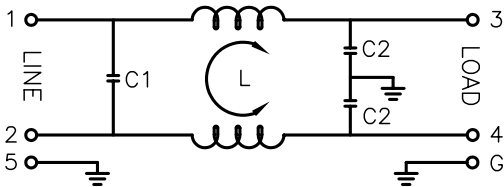

L: 1.5 mH
C1: 0.1 uF
C2: 3300 pF

ELECTRICAL CHARACTERISTICS:

- VOLTAGE RATING: 115/250 VAC
- CURRENT RATING:
 - AT 115VAC: 10 A RMS MAX.
 - AT 250VAC: 10 A RMS MAX.
- OPERATING FREQUENCY: 50/60Hz
- LEAKAGE CURRENT: (EACH LINE TO GROUND)
 - AT 115VAC, 60Hz: 0.25 mA MAX.
 - AT 250VAC, 50Hz: 0.45 mA MAX.
- HIPOT RATING (FOR ONE MINUTE):
 - LINE TO GROUND: 2250 VDC
 - LINE TO LINE: 1450 VDC
- MINIMUM INSERTION LOSS IN dB:

MHz	0.01	0.05	0.10	0.15	0.50	1.0	5.0	10	30
COM. MODE	-	-	-	20	35	35	50	50	45
DIF. MODE	-	-	-	6	20	20	44	45	45

- AMBIENT TEMPERATURE: 40°C
- STORAGE/OPERATING TEMPERATURE: -25°C ~ +85°C
- SAFETY



DISCLAIMER: ALL STATEMENTS AND TECHNICAL INFORMATION CONTAINED HEREIN ARE BASED UPON INFORMATION AND/OR TESTS WE BELIEVE TO BE ACCURATE AND RELIABLE. SINCE CONDITIONS OF USE ARE BEYOND OUR CONTROL, THE USER SHALL DETERMINE THE SUITABILITY OF THE PRODUCT FOR THE INTENDED USE AND ASSUME ALL RISK AND LIABILITY WHATSOEVER IN CONNECTION THEREWITH.

TOLERANCES:

UNLESS OTHERWISE SPECIFIED, DIMENSIONS ARE FOR REFERENCE PURPOSES ONLY.

DRAWN BY:	DATE:
BASAM YOUSIF	05/13/06
CHECKED BY:	DATE:
THOMAS LEE	6/2/06
APPROVED BY:	DATE:
HISHAM ODISH	6/2/06

DRAWING TITLE:			
EMI FILTER RoHS COMPLIANT			
SIZE	DWG. NO.	ELECTRONIC FILE	REV
A	SPC20193	83K9643.DWG	A
SCALE:	NTS	U.O.M.: Millimeters	SHEET: 1 OF 1