

Features

- Cost effective R-C construction
- Insulation resistance testing for reliability
- Molded surface mount or DIP packaging
- Compatible with automatic assembly equipment
- Custom value capability

For information on EMI/RFI Filters, download Bourns' [EMI/RFI Filters Application Note](#).

601 Series - RC Networks T-Filters

General Description

Continual advances in digital IC technology are creating stringent demands on EMI/RFI levels in equipment.

EMI/RFI low pass filters are required in personal computers, data terminals, test equipment and process controllers for high frequency suppression into or out of electronic equipment.

For additional information, see application note on pages 320 and 321.

Electrical Specifications - Resistors

Standard Resistance Range*	10 ohms - 100 ohms
Series Resistance Tolerance	±10 %
Temperature Coefficient of Resistance	±300 ppm/°C
Operating Voltage	25 volts maximum
Operating Temperatures	+10 °C to +85 °C

*Other Resistance Values Available, 10 ohms - 1 megohm

Electrical Specifications - Capacitors

Standard Capacitance Range	50 pF to 200 pF
Capacitance Tolerance	±30 %
Temperature Characteristic	Z5U
Operating Temperatures	+10 °C to +85 °C
Voltage Rating	25 volts
Dielectric Withstand Voltage	2.5 x rated voltage
Insulation Resistance	10,000 megohms minimum

Environmental Specifications - Resistors

	ΔR MAXIMUM
Thermal Shock	±0.5 %
Resistance to Solder Heat	±0.5 %
Terminal Strength	±0.5 %

Mechanical Specifications

Flammability	Conforms to UL94 V-0
Leadframe	Copper, solder coated
Body Material	Epoxy/Novolac
Lead Solderability	Meet requirements of MIL-STD-202 Method 208

For Standard Values Used in Capacitors, Inductors, and Resistors, [click here](#).

4420P

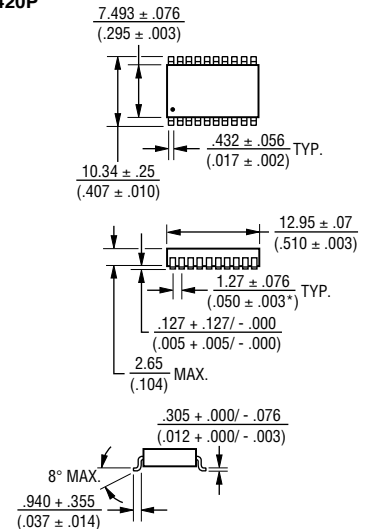

4118R AND 4120R

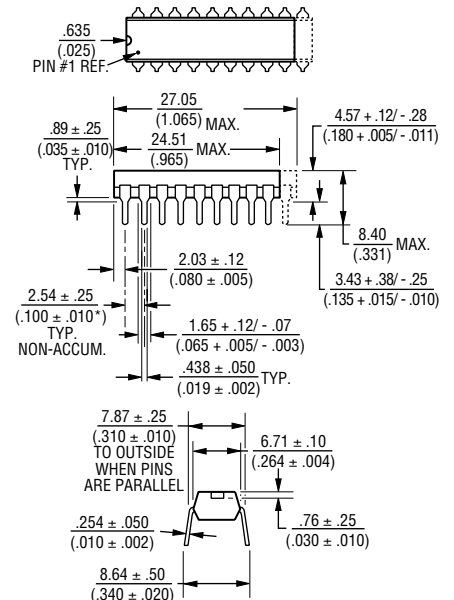

Governing dimensions are metric. Dimensions in parentheses are inches and are approximate.

*Terminal centerline to centerline measurements made at point of emergence of the lead from the body.

601 Series - RC Networks T-Filters



Attenuation Vs. Frequency - Typical Capacitor Values With R= 25 Ohms

Attenuation vs. Frequency
 Model 4120R-601-250/500
 Model 4420-601-250/500
 50pF - 3dB @ 84 MHz

Attenuation vs. Frequency
 Model 4120R-601-250/201
 Model 4420P-601-250/201
 200pF - 3dB @ 21 MHz

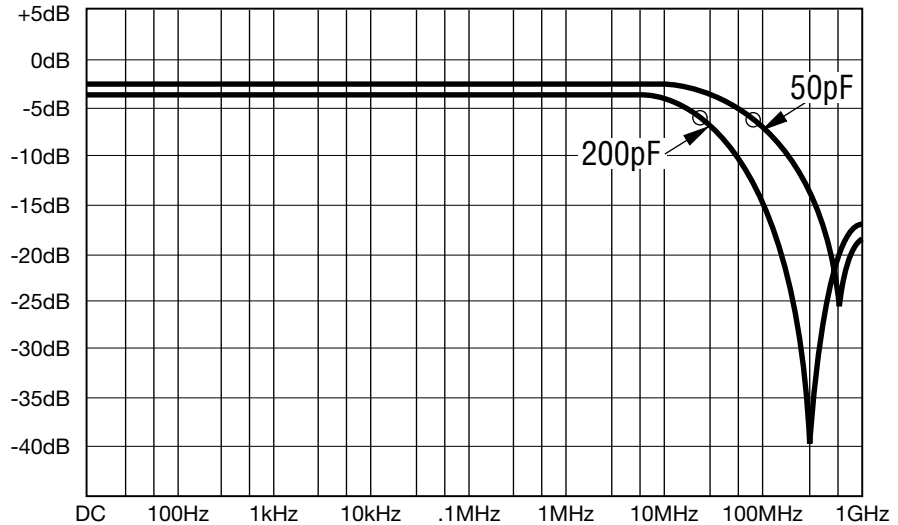

○ indicates - 3dB rolloff frequency (f_c)

These low-pass filters are ideal for installation between I/O drivers and RS 232 connectors.

Typical Circuit

4120R-601-RC/CC
 4420R-601-RC/CC

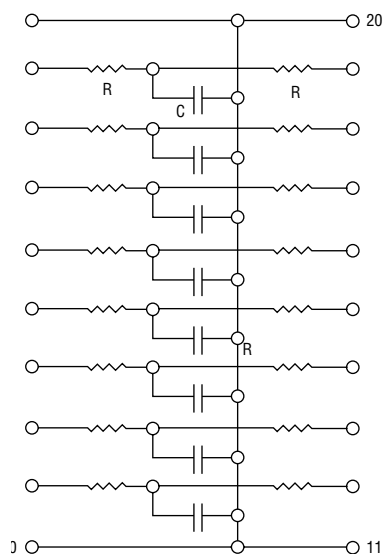

How To Order EMI/RFI Filter Networks

44 20 P - 601 - RC/CC

Model _____
 (44 = SMD SOIC Pkg)
 (41 = Molded DIP)

Number of Pins _____

Physical Configuration _____
 P = Surface Mount Device
 (SMD)
 R = Molded DIP

Resistance/Capacitance Code
 • First 2 digits are significant
 • Third digit represents the
 number of zeros to follow

Electrical Configuration

Insert RC/CC Code from table below to form part number.

RC	R	CC	C
250	25Ω	500	50pF
270	27Ω	101	100pF
470	47Ω	181	180pF
820	82Ω	201	200pF
101	100Ω		

CONSULT FACTORY FOR VALUES NOT LISTED

Packages Available

4420P-601-*RC/CC-SMD
 4120R-601-*RC/CC-DIP
 4118R-601-*RC/CC-DIP

*First two digits are significant. Third digit represents the number of zeros to follow.

Seven circuits in an 18-pin package.
 Eight circuits in a 20-pin package.

REV. 04/06

Specifications are subject to change without notice.
 Customers should verify actual device performance in their specific applications.