



This product is not RoHS compliant.

Features

- Compatible with most modern switching DC/DC converters
- Provides both common-mode and differential-mode filtering
- Facilitates compliance with all conducted-emissions specifications
- Small size; PCB mountable
- -40 to +100°C (case) operation
- UL94V-0 rated package material
- UL approved
- Lucent FLTR100V10/20 compatible

Although agency-imposed conducted-emissions standards are targeted for system-level designs, designers often apply these standards at the component level to ensure system-level compliance. For those DC/DC converters that do not meet these standards, DATEL offers the FLT-100V Series EMI filters. When used with the recommended external capacitors, this family of filters significantly reduces both the common-mode and differential emissions injected back to the power source.

These rugged filters are packaged in non-conductive, UL94V-0 rated, 1" x 2" x 0.5" (FLT-100V10) and 1.6" x 2" x 0.5" (FLT-100V20) packages. Components and the pcb are coated with a humidity-sealing conformal coating and then encapsulated with a thermally conductive potting compound providing outstanding moisture/vibration resistance. Both filters are rated for 100Vdc differential input voltage and are internally bypassed with a telecom/datacom preferred mylar, self-healing, 100Vdc rated capacitor. Input-to-GND and Output-to-GND isolation voltages are guaranteed at 1500Vdc. Inductor copper losses and pcb trace losses are minimized to attain a low Input-to-Output per leg resistance of 9.5mΩ for FLT-100V10 and 4.8mΩ for FLT-100V20 when measured at +25°C. Both Filters are fully characterized to 20MHz for both common-mode and differential-mode dynamic insertion losses. The FLT-100V series EMI filters are UL approved.

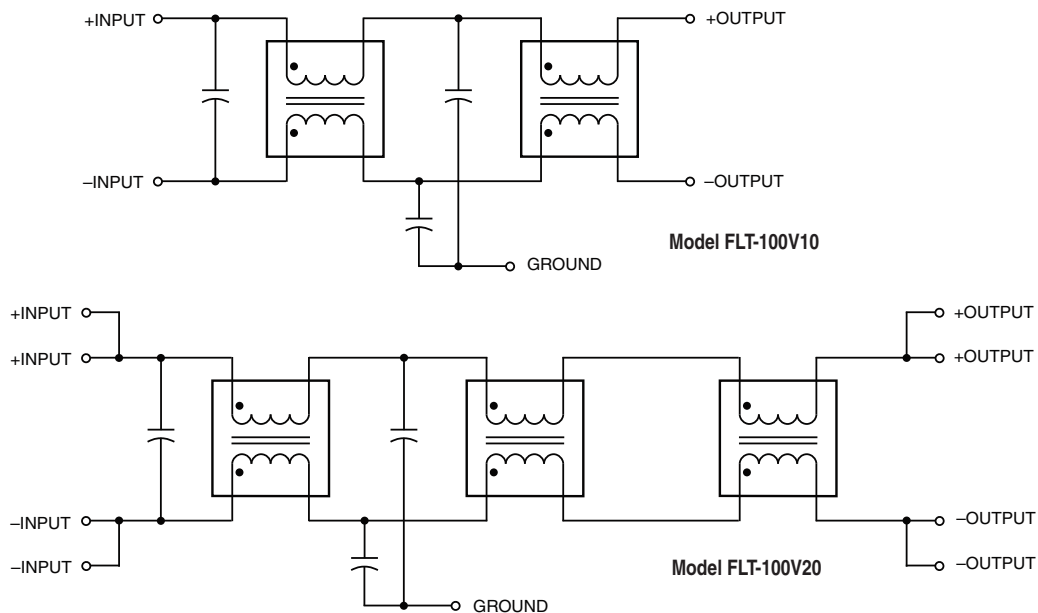

Figure 1. Simplified Schematics

Performance Specifications and Ordering Guide^①

Model	V _{IN} (Volts, max.)	Average current (Amps max.)	Resistance Per Leg Typ. (mΩ, max.)	Common-Mode ^② Insertion Loss (dB, typ.)	Differential-Mode ^② Insertion Loss (dB Typ.)	Package (Case, Pinout)
FLT-100V10	100	10	4.8	-37	-58	F1, P45
FLT-100V20	100	20	9.5	-29	-48	F2, P46

① Specifications at T_A = +25°C unless otherwise noted.
② 50Ω load @ 500kHz.

PART NUMBER STRUCTURE

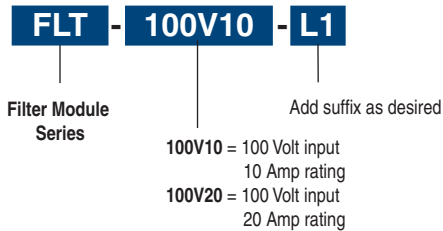

Part Number Suffixes

The FLT-100V series offer shorter pins than those shown in the mechanical specifications drawing.

- L1 Suffix** Short pins: 0.110" (+0.015/-0.010)
- L2 Suffix** Short pins: 0.145" (+0.015/-0.010)

MECHANICAL SPECIFICATIONS

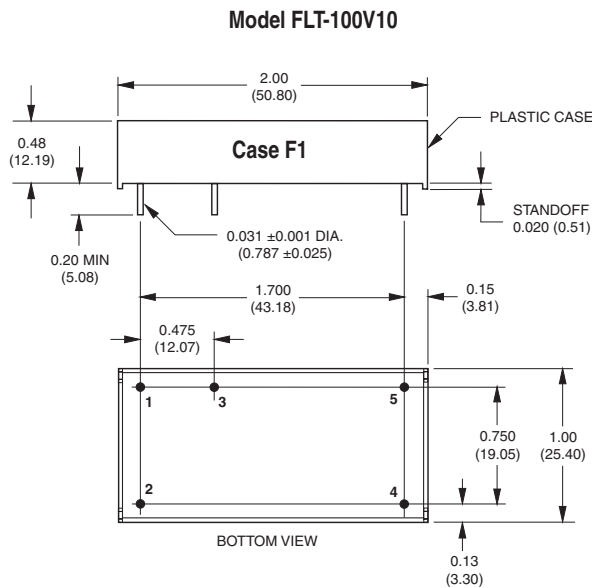

I/O Connections	
Pin	Function P45
1	+Input
2	-Input
3	Ground
4	-Output
5	+Output

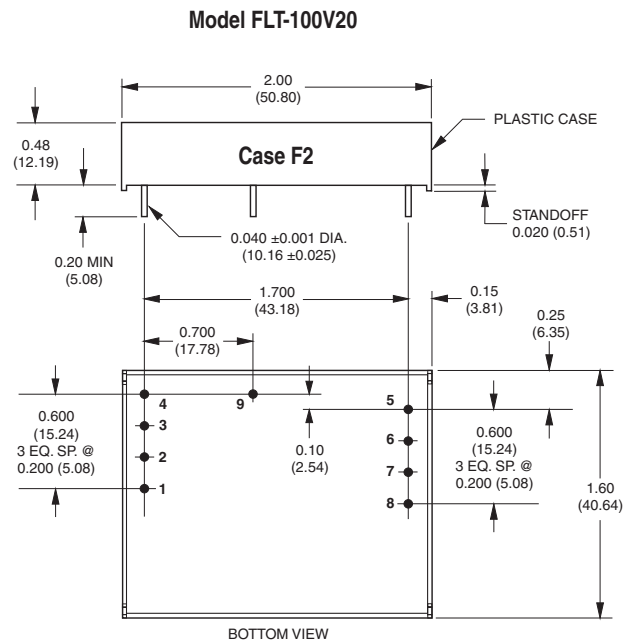

I/O Connections	
Pin	Function P46
1	+Input
2	+Input
3	-Input
4	-Input
5	-Output
6	-Output
7	+Output
8	+Output
9	Ground

Performance/Functional Specifications

Typical @ T_A = +25°C under nominal line voltage, balanced "full-load" conditions, unless noted.

Input	
Input Voltage Range:	100 Volts maximum
Average Current @ +25°C: ①	
FLT-100V10	10 Amps maximum
FLT-100V20	20 Amps maximum
Average Current @ +60°C: ②	
FLT-100V10	10 Amps maximum
FLT-100V20	20 Amps maximum
Resistance Per Leg:	
FLT-100V10:	
@ 25°C	9.5mΩ
@ -40°C	7.6mΩ
@ +125°C	11.8mΩ
FLT-100V20:	
@ 25°C	4.8mΩ
@ -40°C	4mΩ
@ +125°C	6.3mΩ
Isolation Voltage Input to GND	1500Vdc minimum
Isolation Voltage Output to GND	1500Vdc minimum
Dynamic Characteristics	
Differential-Mode Insertion Loss	See Ordering Guide
Common-Mode Insertion Loss	See Ordering Guide
Environmental	
Operating Case Temperature	-40 to +100°C
MTBF @ 100°C Case	
FLT-100V10	2,856,374 hours
FLT-100V20	2,521,681 hours
Storage Temperature	-55 to +125°C
Physical	
Case Material	Plastic, UL 94V-0 rating
Case Dimensions:	
FLT-100V10	1" x 2" x 0.5" (25.4 x 50.8 x 12.7mm)
FLT-100V20	1.6" x 2" x 0.5" (40.6 x 50.8 x 12.7mm)
Pin Material	Brass, solder coated
Pin Diameter:	
FLT-100V10	0.031" (0.787mm)
FLT-100V20	0.040" (1.016mm)
Pin Length	See Part Number Structure
Weight:	
FLT-100V10	1.28 ounces (36.3 grams)
FLT-100V20	2.16 ounces (61.2 grams)
Lead Temperature	
Soldering, 10 seconds	+300°C

① +25°C, 20lfm (natural convection).

② +60°C, 20lfm air flow (natural convection).

Absolute Maximum Ratings	
Input Voltage Range	100 Volts
Isolation Voltage Input to GND	1500Vdc minimum
Isolation Voltage Output to GND	1500Vdc minimum
Operating Case Temperature	-40 to +100°C
Storage Temperature	-55 to +125°C

TECHNICAL NOTES

Description

The FLT-100V series of passive filters are optimized to reduce both common-mode and differential-mode noise on both input and output lines of switching DC/DC converters. The FLT-100V10 is rated for 10A of continuous current while the FLT-100V20 is rated for 20A.

Differential-mode and Common-mode Noise

Designers who are faced with reducing conducted emissions in DC/DC applications must address both differential-mode and common-mode noise. Differences measured between the two input lines of the DC/DC converter are classified as differential noise. The dominant contribution to differential noise is the switching action of the DC/DC converter. Consequently, the majority of noise will be seen at the converter's switching frequency and it's harmonics. The FLT-100V series filter uses a mylar, self healing, 100Vdc rated input capacitor connected between the two input lines (traditionally referred to as "X" capacitors), in conjunction with the leakage inductance of the common mode chokes to attenuate the low-frequency differential noise. In addition to the filter, a low-ESR input capacitor (C1 of Figure 4) is also recommended at the input to the DC/DC to provide a low source impedance and additional noise attenuation.

See typical performance curves for differential-mode insertion loss performance.

Common-mode noise is measured as variations between the input lines (in common) with respect to the Ground pin. Common-mode noise is generally in the high frequency spectrum (>10MHz) and originates in the switching components of the DC/DC converter. A capacitor from each line to the ground pin (referred to as "Y" capacitors), connected between the two common mode chokes, provides attenuation of this unwanted common-mode noise. This ground pin should be connected to a relatively quiet chassis ground point independent from the DC/DC converter case connection. *Note that a noisy chassis ground can inadvertently introduce common noise into the system.* Some DATEL DC/DC converters are designed with an internal input-to-output capacitor to reduce common-mode noise generated from within the converter. In addition, common-mode noise can be reduced with the addition of external ceramic capacitors of 0.1µF to 1.0µF (C2 thru C4 of Figure 4) installed from inputs and outputs to a shield plane connected to the DC/DC case; safety standards may limit the size of these capacitors for some applications. See typical performance curves for common-mode insertion loss performance.

FLT-100V series filters incorporate an internal, multi-layer film polymer capacitor between the input lines for differential-mode noise filtering. This telecom/datacom preferred capacitor provides electrical stability under both AC and DC current loads. The capacitors insulation resistance tends to improve under the stresses of heat and voltage. A typical ESR of 6 milli-OHMs @ 500kHz, provides the necessary low impedance for high frequency input current handling.

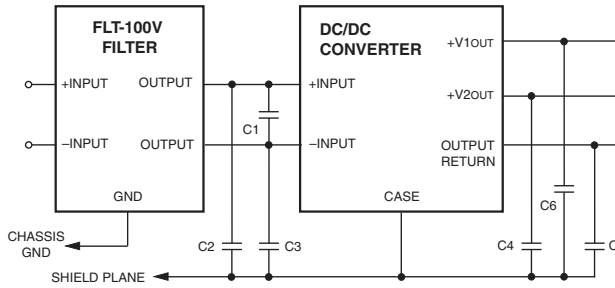

Figure 2. Typical Application Using FLT-100V Series Filters in Front of a DC/DC Converter

Figure 2 shows a typical connection diagram for the attenuation of both differential and common-mode noise when used as an input filter to a DC/DC converter, while Figure 3 shows the recommended layout. Noise introduced into circuits is dependent upon the characteristics of the load, layout and grounding techniques, and cabling. Since application requirements differ, the final circuit configurations may be best obtained through empirical testing.

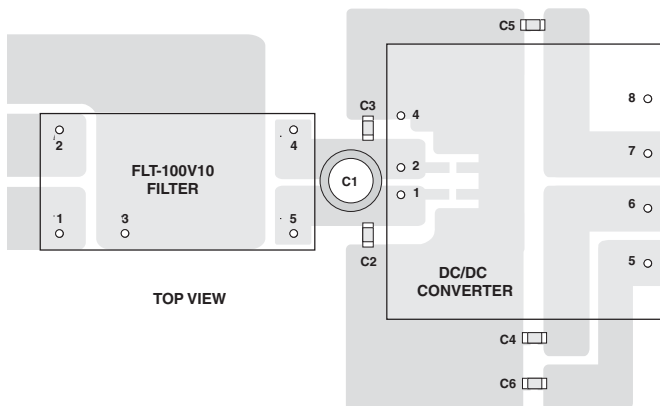
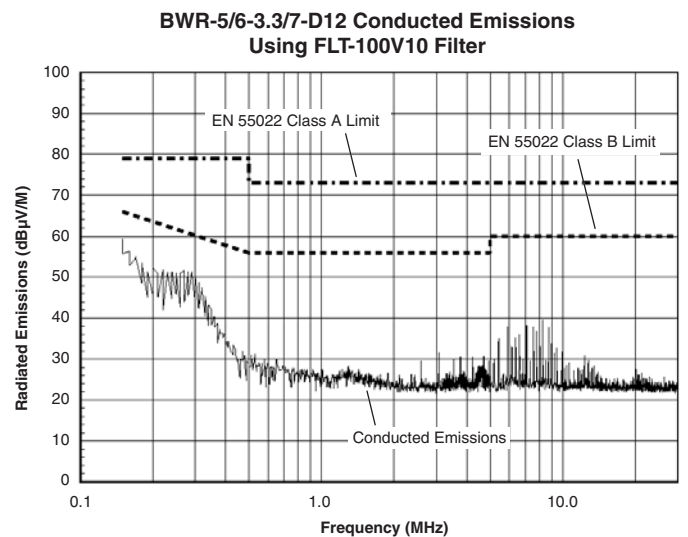
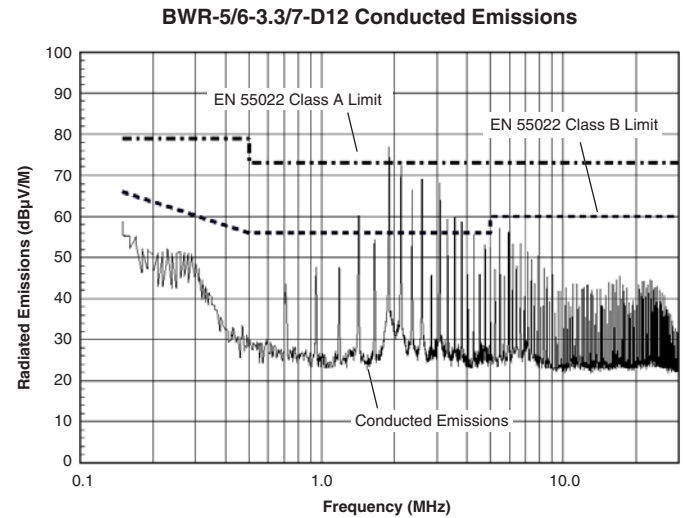

Figure 3. Typical Layout Using FLT-100V Series Filters in Front of a DATEL BWR-5/6-3.3/7-D12 Dual-Output DC/DC Converter

Conducted Emissions Performance

Conducted Emissions standards imposed by governing agencies must be met at the system level, not the component level. Many designers, however, apply these standards to the individual components to assure system-level compliance. The following performance graphs show the Conducted Emissions improvements seen when using an FLT-100V series filter in series with the input lines of a typical switching DC/DC converter. Conducted Emissions testing was performed within a EMCO 5305 GTEM test cell utilizing EMCO automated EMC test software. Signal levels were measured from an EMCO 3825/2 Line Impedance Stabilization Network (LISN) using a Hewlett Packard 8568B spectrum analyzer with an attached Hewlett Packard 85650A quasi-peak adapter in peak detection. Limits are based on FCC Part 15 Subpart J Class A and B, as well as EN 55022 Class A and B.



Operating Temperature

Both the FLT-100V10 and FLT-100V20 are guaranteed for operation up to +100°C case temperature. Performance graphs (see typical performance curves) are provided for both models that depict the case temperature rise versus average current for various air flow conditions.

On/Off Control and External Fusing

To eliminate any current-path bypassing of the filter, the on/off control circuitry used to control the DC/DC converter should be referenced to the -Input pin of the converter and not to the -Input of the filter. The FLT-100V series filters do not provide internal fusing, therefore an external fuse of appropriate DC/DC rating should be provided externally.

Using a Single Filter with Multiple Converters

A single FLT-100V series filter can be used with multiple DC/DC converters provided that the maximum rated current is observed. The use of common-mode chokes in the design of these filters, however, requires that the +Input current and -Input current be equal. A small imbalance in these currents may cause the inductor to saturate and degrade the filter's performance.

Input Capacitor

FLT-100V series filters incorporate an internal, multi-layer film polymer capacitor between the input lines for differential-mode noise filtering. This telecom/datacom preferred capacitor provides electrical stability under both AC and DC current loads. The capacitor's insulation resistance tends to improve under the stresses of heat and voltage. A typical ESR of 6 milliohms @ 500kHz, provides the necessary low impedance for high frequency input current handling.

Using FLT-100V as an Output Filter

Although optimized for use as an input conducted emissions filter, the FLT-100V series can be used as an output filter for DC/DC converters to reduce output ripple and attenuate high frequency noise. Figures 4 and 5 show the recommended connections for both unipolar and bipolar applications. Depending upon application and desired performance, the Gnd pin connection can be made at the output return, case shield plane, or left floating. Output ripple and noise improvements are shown in the following illustrations for a typical DC/DC converter that is using the setup shown in Figure 5.

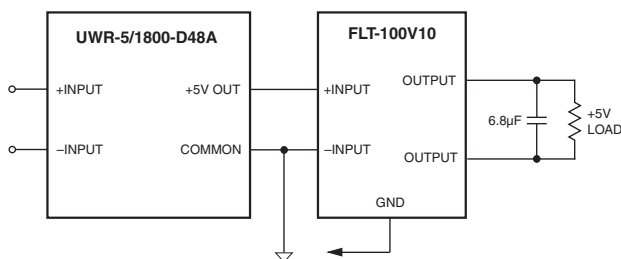

Figure 4. Using FLT-100V10 as an Output Filter for Unipolar DC/DC

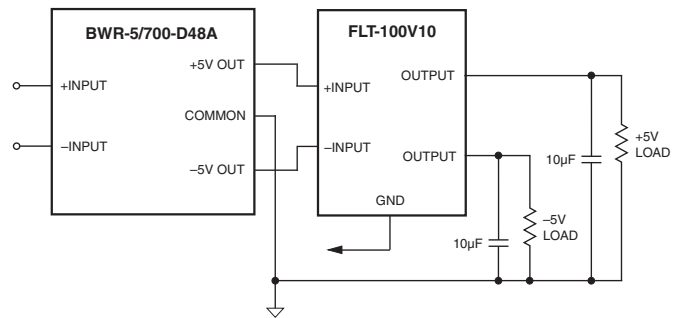
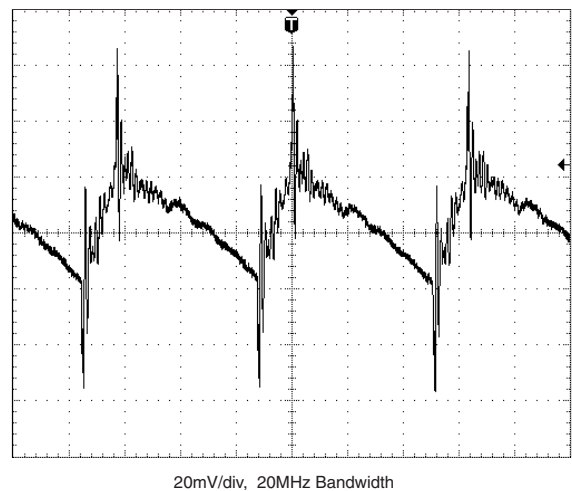
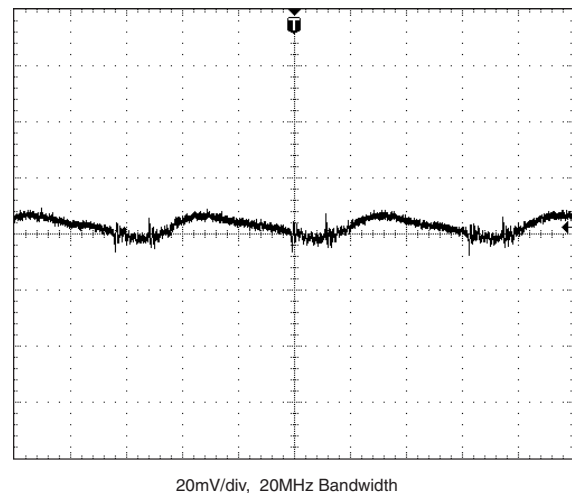

Figure 5. Using FLT-100V10 as an Output Filter for Bipolar DC/DC

Output Ripple and Noise of BWR-5/700-D48A
(No external capacitance.)



Output Ripple and Noise of BWR-5/700-D48A
(Using single leg of FLT-100V10 and 10µF capacitance.)



Case Temperature Rise vs. Average Current and Air Flow

FLT-100V10

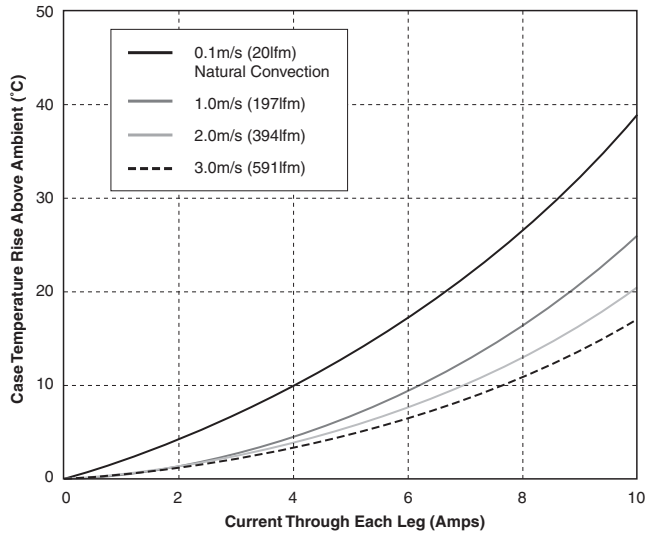

FLT-100V20

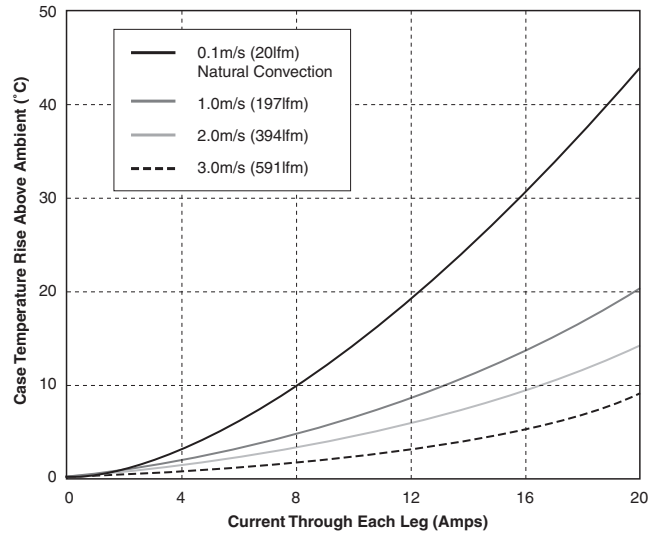

Typical Differential-Mode Insertion Loss Curves

FLT-100V10 Differential-Mode Insertion Loss
(Into 50 Ohm Load)

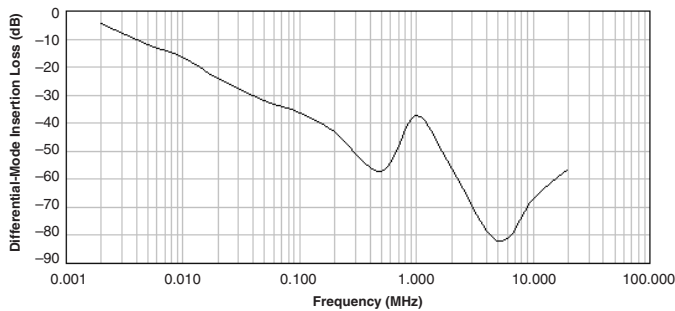

FLT-100V20 Differential-Mode Insertion Loss
(Into 50 Ohm Load)

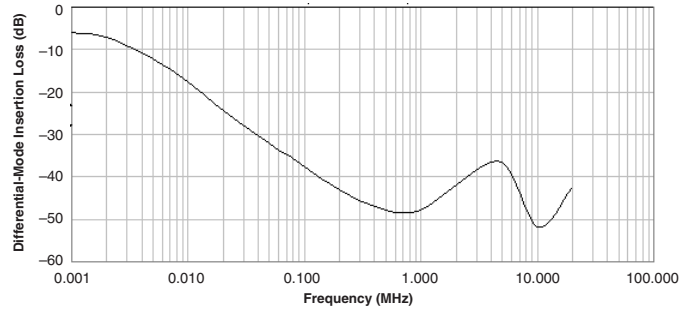

Typical Common-Mode Insertion Loss Curves

FLT-100V10 Common-Mode Insertion Loss
(Into 50 Ohm Load)

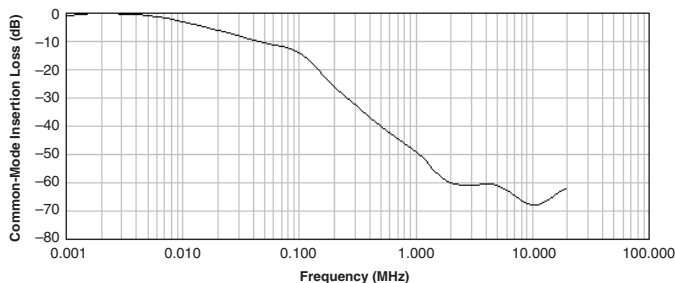

FLT-100V20 Common-Mode Insertion Loss
(Into 50 Ohm Load)

