

MARKETING SALES DRAWING
DIMENSIONS IN INCHES - DO NOT SCALE THIS DRAWING
DIMENSIONS IN METRIC - []

Electrical Testing
per Tusonix standard
test plans and Mil-Std-202
Test Methods.

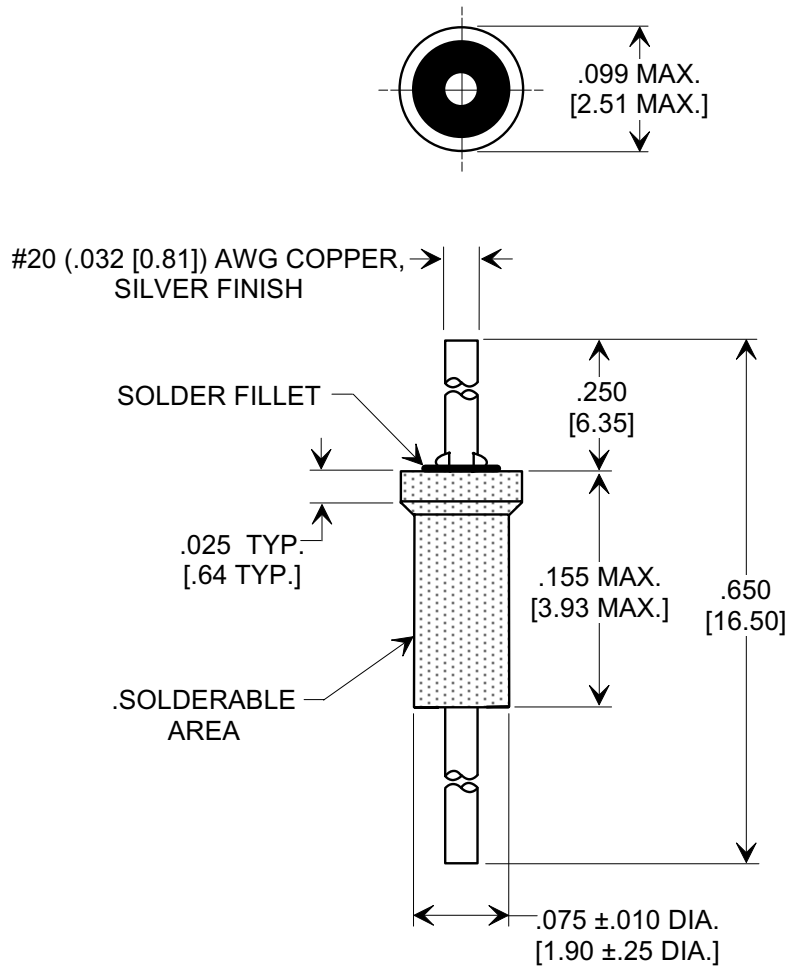
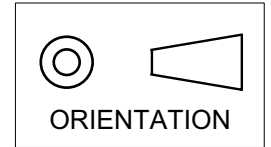

NOTES:

- TUSONIX STANDARD PART NUMBER: 2463-002-X5U0-152P.
TUSONIX RoHS COMPLIANT PART
NUMBER: 2463-002-X5U0-152P LF.
CUSTOMER MUST SPECIFY STANDARD OR RoHS PART
NUMBER WHEN ORDERING.
- PART MARKING: STANDARD PART, NO MARKING.
RoHS PART: GREEN LABELING ON PACKAGING.

SPECIFICATIONS

CAP. VALUE	1500 pF
CAP. TOL.	+100, -0%
TEMP. CHAR.	X5U
OPERATING TEMP.	-55° TO +125°C
OPERATING VOLT.	100 WVDC

X-2015 Rev-0 REVISION RECORD Original Release C.O. 19980305-3-03 ADDED NOTES & SILVER FINISH. S.M. 05-20-05 20050504-6-02	0	1	--TOLERANCES-- Unless Otherwise Specified	Title SHOULDER FEED-THRU			
	DECIMAL ± .031 [0.79]		Drawn S.M. 03-10-98	Scale NONE			
	ANGLES ±		Approved J.Mc. 03-10-98				
	TUSONIX TUCSON, ARIZONA		A	2463-002-X5U0-152P			