

DATA SHEET

E58/11/38 Planar E cores

Product specification
Supersedes data of November 1997
File under Ferrite Ceramics, MA01

1999 Dec 23

Planar E cores

E58/11/38

CORES

Effective core parameters of a set of E cores

SYMBOL	PARAMETER	VALUE	UNIT
$\Sigma(l/A)$	core factor (C1)	0.268	mm ⁻¹
V_e	effective volume	24600	mm ³
l_e	effective length	81.2	mm
A_e	effective area	305	mm ²
m	mass of core half	≈62	g

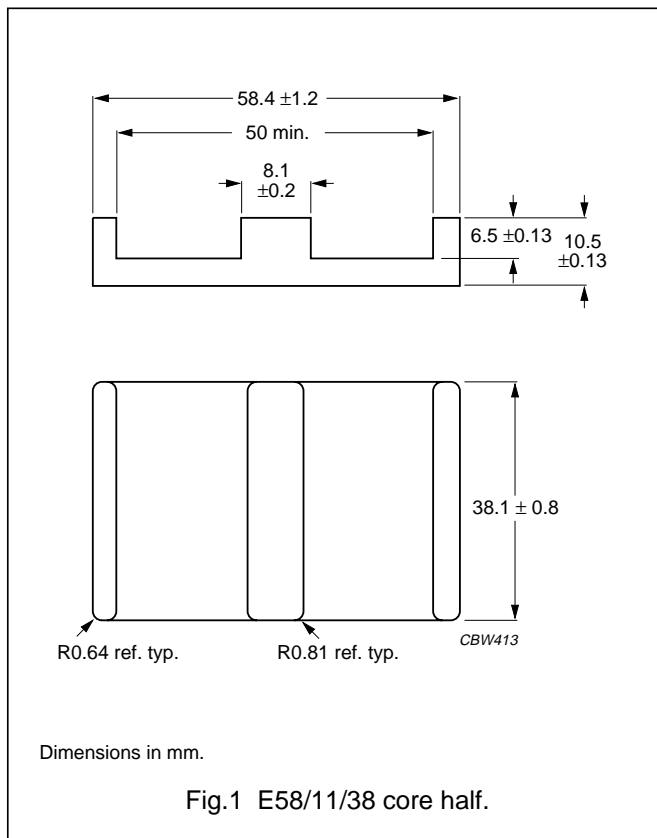

Effective core parameters of an E/PLT combination

SYMBOL	PARAMETER	VALUE	UNIT
$\Sigma(l/A)$	core factor (C1)	0.224	mm ⁻¹
V_e	effective volume	20800	mm ³
l_e	effective length	68.3	mm
A_e	effective area	305	mm ²
m	mass of core half	≈44	g

Ordering information for plates

GRADE	TYPE NUMBER
3C90	PLT58/38/4-3C90
3F3	PLT58/38/4-3F3
3F4 des	PLT58/38/4-3F4

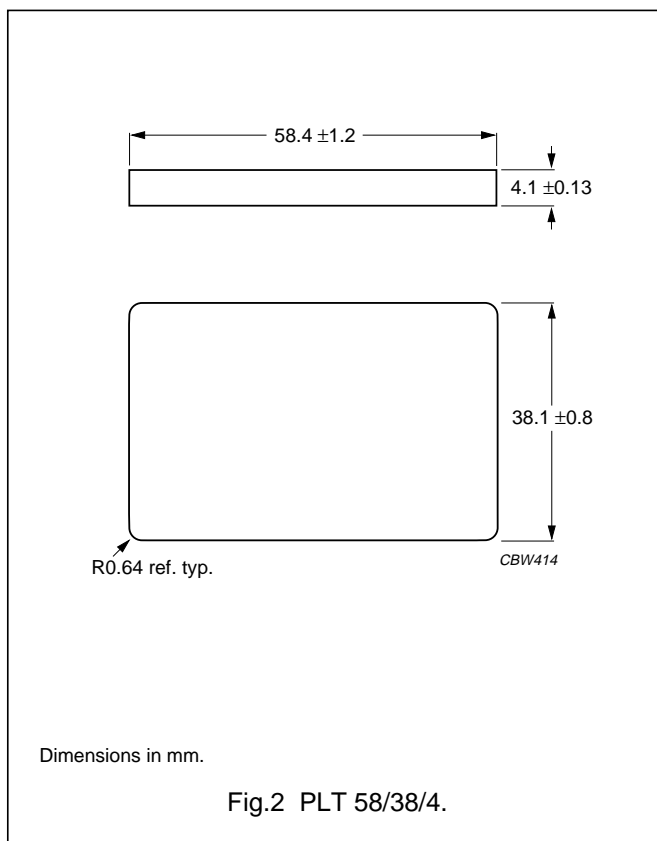

Planar E cores

E58/11/38

Core halves for use in combination with an E coreA_L measured in combination with a non-gapped core half, clamping force for A_L measurements, 40 ±20 N.

GRADE	A _L (nH)	μ _e	AIR GAP (μm)	TYPE NUMBER
3C90	315 ±3% ⁽¹⁾	≈67	≈1400	E58/11-3C90-E315-E
	400 ±3% ⁽¹⁾	≈85	≈1100	E58/11-3C90-E400-E
	630 ±5% ⁽¹⁾	≈134	≈650	E58/11-3C90-E630-E
	1000 ±5%	≈213	≈400	E58/11-3C90-A1000-E
	1600 ±10%	≈341	≈200	E58/11-3C90-A1600-E
	8480 ±25%	≈1800	≈0	E58/11/38-3C90
3F3	315 ±3% ⁽¹⁾	≈67	≈1400	E58/11-3F3-E315-E
	400 ±3% ⁽¹⁾	≈85	≈1100	E58/11-3F3-E400-E
	630 ±5% ⁽¹⁾	≈134	≈650	E58/11-3F3-E630-E
	1000 ±5%	≈213	≈400	E58/11-3F3-A1000-E
	1600 ±10%	≈341	≈200	E58/11-3F3-A1600-E
	7710 ±25%	≈1640	≈0	E58/11/38-3F3
3F4 <small>des</small>	315 ±3% ⁽¹⁾	≈67	≈1400	E58/11-3F4-E315-E
	400 ±3% ⁽¹⁾	≈85	≈1100	E58/11-3F4-E400-E
	630 ±5% ⁽¹⁾	≈134	≈650	E58/11-3F4-E630-E
	1000 ±5%	≈213	≈400	E58/11-3F4-A1000-E
	1600 ±10%	≈341	≈200	E58/11-3F4-A1600-E
	4030 ±25%	≈860	≈0	E58/11/38-3F4

Note1. Measured in combination with an equal gapped E core half, clamping force for A_L measurements, 40 ±20 N.**Core halves for use in combination with a plate (PLT)**A_L measured in combination with a plate (PLT), clamping force for A_L measurements, 40 ±20 N.

GRADE	A _L (nH)	μ _e	AIR GAP (μm)	TYPE NUMBER
3C90	315 ±3%	≈56	≈1400	E58/11-3C90-A315-P
	400 ±3%	≈71	≈1100	E58/11-3C90-A400-P
	630 ±5%	≈112	≈650	E58/11-3C90-A630-P
	1000 ±5%	≈178	≈400	E58/11-3C90-A1000-P
	1600 ±10%	≈285	≈200	E58/11-3C90-A1600-P
	9970 ±25%	≈780	≈0	E58/11/38-3C90
3F3	315 ±3%	≈56	≈1400	E58/11-3F3-A315-P
	400 ±3%	≈71	≈1100	E58/11-3F3-A400-P
	630 ±5%	≈112	≈650	E58/11-3F3-A630-P
	1000 ±5%	≈178	≈400	E58/11-3F3-A1000-P
	1600 ±10%	≈285	≈200	E58/11-3F3-A1600-P
	9070 ±25%	≈1620	≈0	E58/11/38-3F3

Planar E cores

E58/11/38

GRADE	A_L (nH)	μ_e	AIR GAP (μm)	TYPE NUMBER
3F4 <small>des</small>	315 \pm 3%	\approx 56	\approx 1400	E58/11-3F4-A315-P
	400 \pm 3%	\approx 71	\approx 1100	E58/11-3F4-A400-P
	630 \pm 5%	\approx 112	\approx 650	E58/11-3F4-A630-P
	1000 \pm 5%	\approx 178	\approx 400	E58/11-3F4-A1000-P
	1600 \pm 10%	\approx 285	\approx 200	E58/11-3F4-A1600-P
	4780 \pm 25%	\approx 850	\approx 0	E58/11/38-3F4

Properties under power conditions

CORE COMBINATION	B (mT) at	CORE LOSS (W) at				
	H = 250 A/m; f = 10 kHz; T = 100 °C	f = 25 kHz; \hat{B} = 200 mT; T = 100 °C	f = 100 kHz; \hat{B} = 100 mT; T = 100 °C	f = 400 kHz; \hat{B} = 50 mT; T = 100 °C	f = 1 MHz; \hat{B} = 30 mT; T = 100 °C	f = 3 MHz; \hat{B} = 10 mT; T = 100 °C
E+E58-3C90	\geq 320	\leq 2.95	\leq 3.10	–	–	–
E+PLT58-3C90	\geq 320	\leq 2.50	\leq 2.65	–	–	–
E+E58-3F3	\geq 320	–	\leq 2.70	\leq 4.70	–	–
E+PLT58-3F3	\geq 320	–	\leq 2.30	\leq 4.00	–	–
E+E58-3F4	\geq 250	–	–	–	\leq 7.40	\leq 8.00
E+PLT58-3F4	\geq 250	–	–	–	\leq 6.25	\leq 6.80