

SMD Choke Coils

Series: **G**
 Type: **ELLVEG**
ELLVFG-C
ELLVGG



■ Features

- Magnetically shielded structure
- Low DC resistance and large current capability
- Shock resistant

■ Recommended Applications

- DC-DC converter circuitry for computer peripherals and cellular phones.
- Chopper circuit decoupling chokes for DC-DC converter circuitry.

■ Standard Packing Quantity

- 2000 pcs./Reel

■ Explanation of Part Numbers

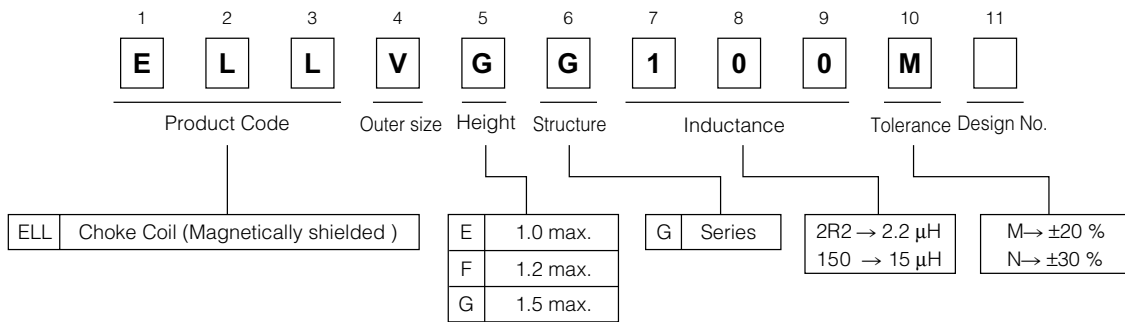

■ Dimensions in mm (not to scale)

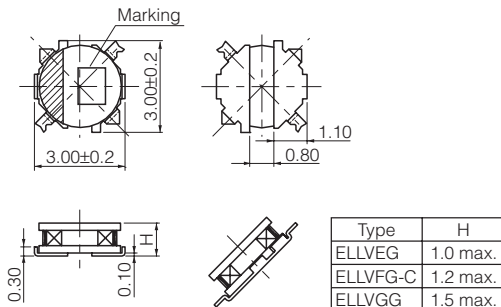

■ Recommended land patterns in mm (not to scale)

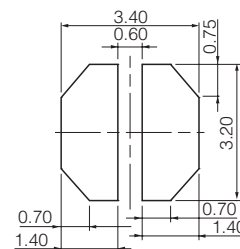

Standard Parts

Series	Part Number	Inductance (100 kHz)		R ^{DC} (at 20 °C)		Saturation Rated Current* ¹ (mA max.)	Temperature Rise Current* ² (mA max.)	Marking
		(μH)	Tol.	(mΩ)	Tol.			
VEG Series	ELLVEG1R0N	1.0	±30 %	61	±20 %	1900	1600	A
	ELLVEG1R5N	1.5		74		1200	1400	C
	ELLVEG2R2N	2.2		110		1100	1250	D
	ELLVEG3R3N	3.3		210		1000	820	E
	ELLVEG4R7N	4.7		240		750	770	H
	ELLVEG6R8N	6.8	350	580		650	K	
	ELLVEG100M	10.0	480	520		600	M	
	ELLVEG150M	15.0	710	430		490	O	
	ELLVEG220M	22.0	1200	330		400	R	
	ELLVEG330M	33.0	2300	260		290	T	
	ELLVEG470M	47.0	2700	220		250	V	
ELLVEG680M	68.0	3500	180	220	X			
VFG Series	ELLVFG1R0NC	1.0	±30 %	50	±20 %	1500	1700	a
	ELLVFG1R5NC	1.5		61		1300	1550	c
	ELLVFG2R2NC	2.2		87		1100	1400	d
	ELLVFG3R3NC	3.3		110		980	1250	e
	ELLVFG4R7NC	4.7		150		740	1050	h
	ELLVFG6R8MC	6.8	230	600		840	k	
	ELLVFG100MC	10.0	380	550		640	m	
	ELLVFG150MC	15.0	540	500		480	o	
	ELLVFG220MC	22.0	710	350		430	r	
	ELLVFG330MC	33.0	1160	280		330	t	
	VGG Series	ELLVGG1R0N	1.0	±30 %		52	±20 %	2200
ELLVGG1R6N		1.6	73		1800	1550		C
ELLVGG2R2N		2.2	92		1600	1400		D
ELLVGG3R3N		3.3	130		1350	1100		E
ELLVGG3R9N		3.9	150		1300	1000		F
ELLVGG4R7N		4.7	170	1200	980	H		
ELLVGG6R8N		6.8	230	1000	800	K		
ELLVGG100M		10.0	280	800	730	M		
ELLVGG120M		12.0	480	690	580	N		
ELLVGG150M		15.0	640	600	490	O		
ELLVGG220M		22.0	800	500	460	R		
ELLVGG330M		33.0	1330	450	340	T		
ELLVGG470M		47.0	2100	350	270	V		

*1 Saturation Rated Current : This DC current which causes a 30 % inductance reduction from its nominal value.

*2 Temperature Rise Current : This indicates the value of current when temperature rise dt/t= 40 °C (at 20 °C).

Embossed Carrier Tape Dimensions in mm (not to scale)

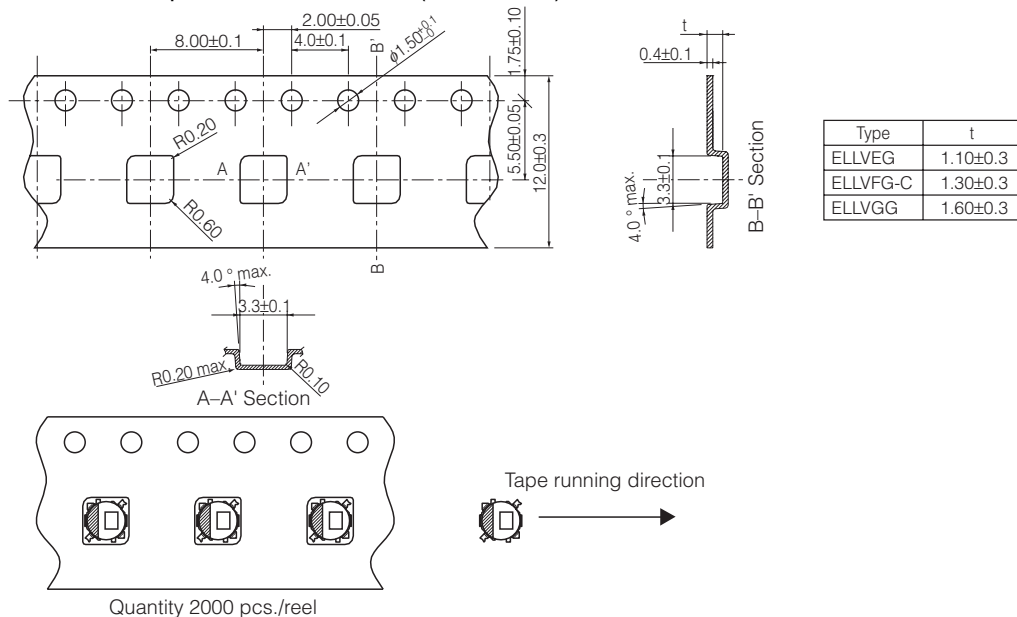

Design and specifications are each subject to change without notice. Ask factory for the current technical specifications before purchase and/or use. Should a safety concern arise regarding this product, please be sure to contact us immediately.