

SMD Choke Coils

Series: **V**
 Type: **ELLCTV**



Type ELLCTV

■ Features

- Magnetically shielded structure
- Low DC resistance and large current capability
- Available on tape and reel for automatic insertion

■ Recommended Applications

- DC-DC converter circuitry for computer peripherals and cellular phones.
- Chopper circuit decoupling chokes for DC-DC converter circuitry

■ Standard Packing Quantity

- 500 pcs./Reel

■ Explanation of Part Numbers

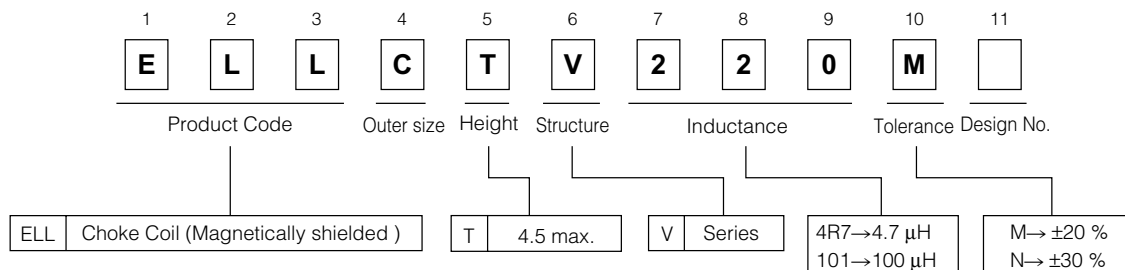

■ Dimensions in mm (not to scale)

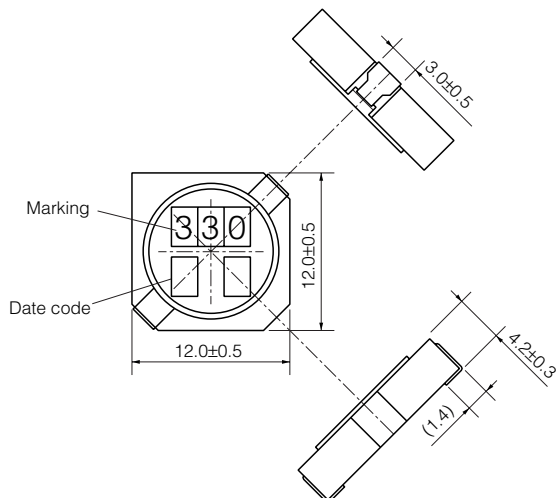

■ Recommended Land Pattern in mm (not to scale)

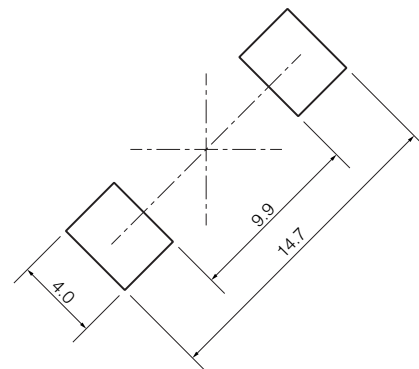

Standard Parts

Part No.	Inductance (100 kHz)		RDC (at 20 °C)		* Rated Current (mA) max.	Marking
	(μH)	Tolerance	(mΩ)	Tolerance		
ELLCTV1R2N	1.2	±30 %	4.6	±20 %	6500	1R2
ELLCTV2R0N	2.0		5.6		6300	2R0
ELLCTV2R7N	2.7		7.0		5700	2R7
ELLCTV3R9N	3.9		8.5		5600	3R9
ELLCTV4R7N	4.7		9.9		5200	4R7
ELLCTV5R6N	5.6		11		4900	5R6
ELLCTV6R8N	6.8		14		4500	6R8
ELLCTV8R2N	8.2		15		4400	8R2
ELLCTV100M	10.0	±20 %	17	3900	100	
ELLCTV120M	12.0		22	3700	120	
ELLCTV150M	15.0		25	3100	150	
ELLCTV180M	18.0		30	3000	180	
ELLCTV220M	22.0		37	2700	220	
ELLCTV270M	27.0		43	2300	270	
ELLCTV330M	33.0		50	2200	330	
ELLCTV390M	39.0		61	2100	390	
ELLCTV470M	47.0		69	1900	470	
ELLCTV560M	56.0		87	1600	560	
ELLCTV680M	68.0		100	1500	680	
ELLCTV820M	82.0		120	1400	820	
ELLCTV101M	100.0		150	1200	101	
ELLCTV121M	120.0		190	1100	121	
ELLCTV151M	150.0		220	1000	151	
ELLCTV181M	180.0		270	930	181	
ELLCTV221M	220.0	310	840	221		
ELLCTV271M	270.0	400	810	271		
ELLCTV331M	330.0	500	660	331		
ELLCTV391M	390.0	560	630	391		
ELLCTV471M	470.0	690	580	471		
ELLCTV561M	560.0	810	540	561		
ELLCTV681M	680.0	1010	470	681		
ELLCTV821M	820.0	1140	440	821		
ELLCTV102M	1000.0	1500	410	102		

* Current: This indicates the value of current when the inductance is 70 % of nominal value or when the case temperature has risen 45 °C (at 20 °C)

Embossed Carrier Tape Dimensions in mm (not to scale)

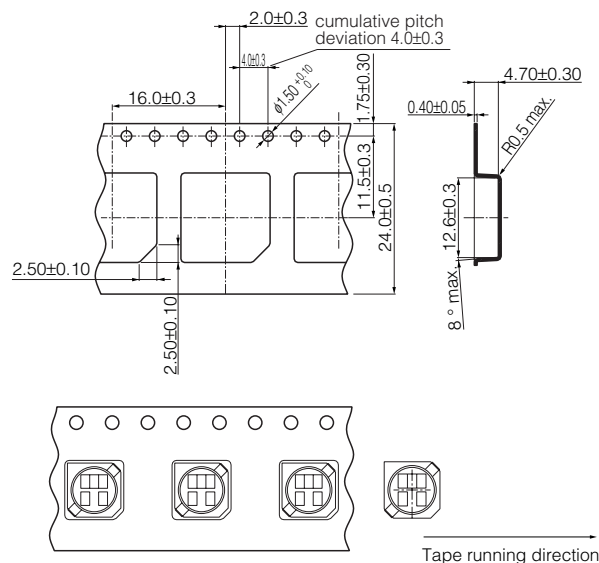

Quantity 500 pcs./reel

Design and specifications are each subject to change without notice. Ask factory for the current technical specifications before purchase and/or use. Should a safety concern arise regarding this product, please be sure to contact us immediately.