

DATA SHEET

RM4/I RM cores and accessories

Product specification
Supersedes data of November 1997
File under Ferrite Ceramics, MA01

1999 Dec 23

RM cores and accessories

RM4/I

CORE SETS

Effective core parameters

SYMBOL	PARAMETER	VALUE	UNIT
$\Sigma(l/A)$	core factor (C1)	1.69	mm ⁻¹
V_e	effective volume	322	mm ³
l_e	effective length	23.3	mm
A_e	effective area	13.8	mm ²
A_{min}	minimum area	11.5	mm ²
m	mass of set	≈1.7	g

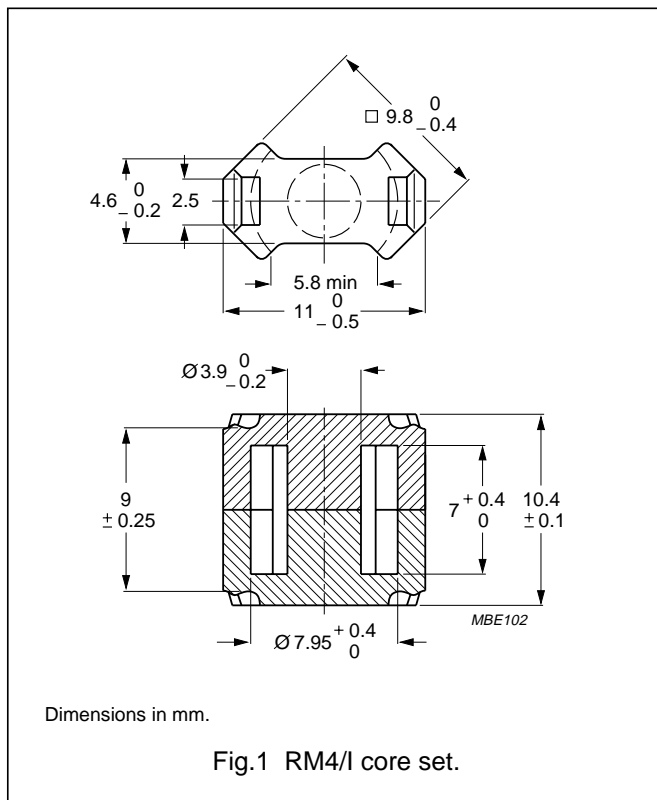

Core sets for general purpose transformers and power applications

Clamping force for A_L measurements, 10 ±5 N.

GRADE	A_L (nH)	μ_e	AIR GAP (μ m)	TYPE NUMBER
3C90	1125 ±25%	≈1520	≈0	RM4/I-3C90
3C94 des	1125 ±25%	≈1520	≈0	RM4/I-3C94
3C96 prot	1000 ±25%	≈1350	≈0	RM4/I-3C96
3F3	100 ±3%	≈134	≈170	RM4/I-3F3-A100
	160 ±3%	≈215	≈100	RM4/I-3F3-A160
	250 ±10%	≈336	≈50	RM4/I-3F3-A250
	950 ±25%	≈1280	≈0	RM4/I-3F3
3F35 prot	800 ±25%	≈1080	≈0	RM4/I-3F35
3F4 des	100 ±3%	≈134	≈150	RM4/I-3F4-A100
	160 ±3%	≈215	≈80	RM4/I-3F4-A160
	250 ±10%	≈336	≈40	RM4/I-3F4-A250
	560 ±25%	≈750	≈0.12	RM4/I-3F4

RM cores and accessories

RM4/I

Core sets of high permeability grades

Clamping force for A_L measurements, 10 ± 5 N.

GRADE	A (nH)	μ_e	TYPE NUMBER
3E1 ^{sup}	1800 $\pm 25\%$	≈ 2400	RM4/I-3E1
3E4 ^{sup}	2500 +40/-30%	≈ 3360	RM4/I-3E4
3E5	3500 +40/-30%	≈ 4700	RM4/I-3E5

Properties of core sets under power conditions

GRADE	B (mT) at	CORE LOSS (W) at			
	H = 250 A/m; f = 25 kHz; T = 100 °C	f = 25 kHz; \hat{B} = 200 mT; T = 100 °C	f = 100 kHz; \hat{B} = 100 mT; T = 100 °C	f = 100 kHz; \hat{B} = 200 mT; T = 100 °C	f = 400 kHz; \hat{B} = 50 mT; T = 100 °C
3C90	≥ 320	≤ 0.039	≤ 0.04	–	–
3C94	≥ 320	–	≤ 0.03	≈ 0.14	≈ 0.07
3C96	≥ 320	–	≈ 0.02	≈ 0.10	≈ 0.05
3F3	≥ 300	–	≤ 0.05	–	≤ 0.07
3F35	≥ 300	–	–	–	≈ 0.03
3F4	≥ 250	–	–	–	–

Properties of core sets under power conditions (continued)

GRADE	B (mT) at	CORE LOSS (W) at			
	H = 250 A/m; f = 25 kHz; T = 100 °C	f = 500 kHz; \hat{B} = 50 mT; T = 100 °C	f = 500 kHz; \hat{B} = 100 mT; T = 100 °C	f = 1 MHz; \hat{B} = 30 mT; T = 100 °C	f = 3 MHz; \hat{B} = 10 mT; T = 100 °C
3C90	≥ 320	–	–	–	–
3C94	≥ 320	–	–	–	–
3C96	≥ 320	–	–	–	–
3F3	≥ 300	–	–	–	–
3F35	≥ 300	≈ 0.05	≈ 0.35	–	–
3F4	≥ 250	–	–	≤ 0.065	≤ 0.11

RM cores and accessories

RM4/I

COIL FORMERS

General data

PARAMETER	SPECIFICATION
Coil former material	liquid crystal polymer (LCP), glass-reinforced, flame retardant in accordance with "UL 94V-0"; UL file number E83005(M)
Pin material	copper-tin alloy (CuSn), tin-lead alloy (SnPb) plated
Maximum operating temperature	155 °C, "IEC 60085" class F
Resistance to soldering heat	"IEC 60068-2-20", Part 2, Test Tb, method 1B, 350 °C, 3.5 s
Solderability	"IEC 60068-2-20", Part 2, Test Ta, method 1

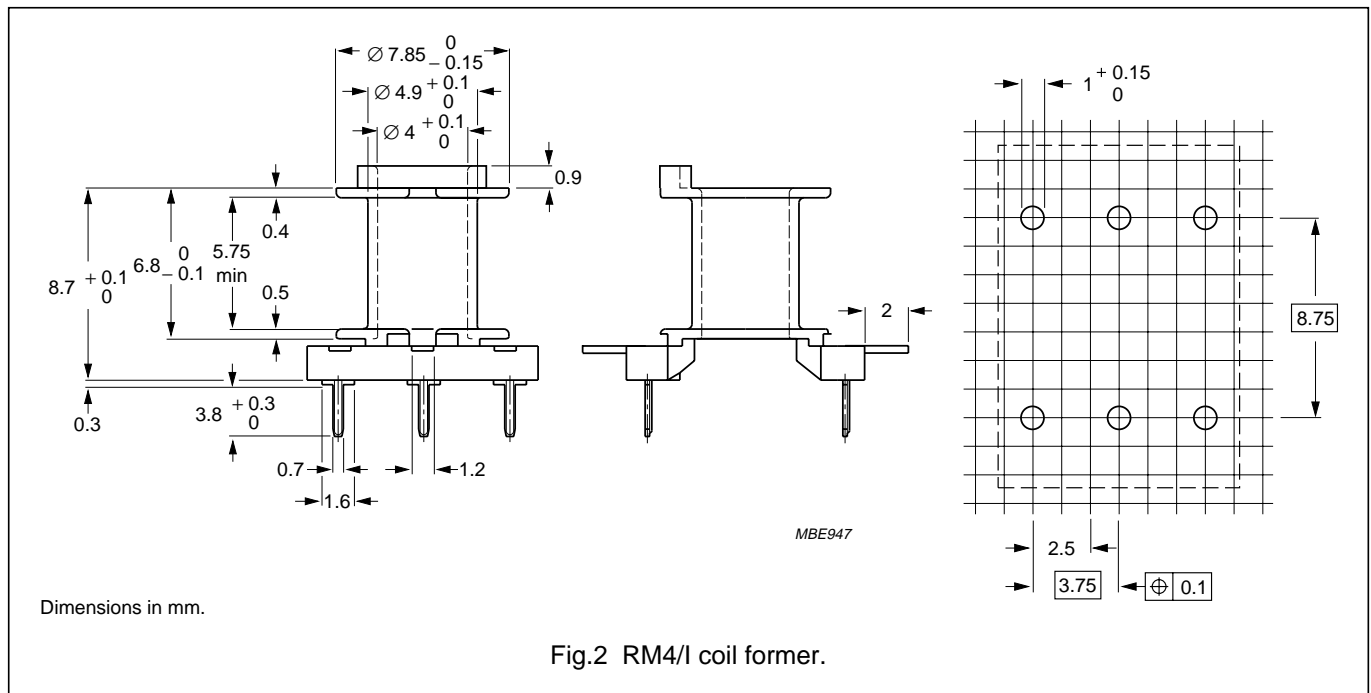

Winding data for RM4 coil former

NUMBER OF SECTIONS	WINDING AREA (mm ²)	WINDING WIDTH (mm)	AVERAGE LENGTH OF TURN (mm)	TYPE NUMBER
1	8.4	5.75	19.8	CPV-RM4-1S-6PD

RM cores and accessories

RM4/I

General data

PARAMETER	SPECIFICATION
Coil former material	liquid crystal polymer (LCP), glass-reinforced, flame retardant in accordance with "UL 94V-0"; UL file number E83005(M)
Solder pad material	copper-tin alloy (CuSn), tin-lead alloy (SnPb) plated
Maximum operating temperature	155 °C, "IEC 60085" class F
Resistance to soldering heat	"IEC 60068-2-20", Part 2, Test Tb, method 1B, 350 °C, 3.5 s
Solderability	"IEC 60068-2-20", Part 2, Test Ta, method 1

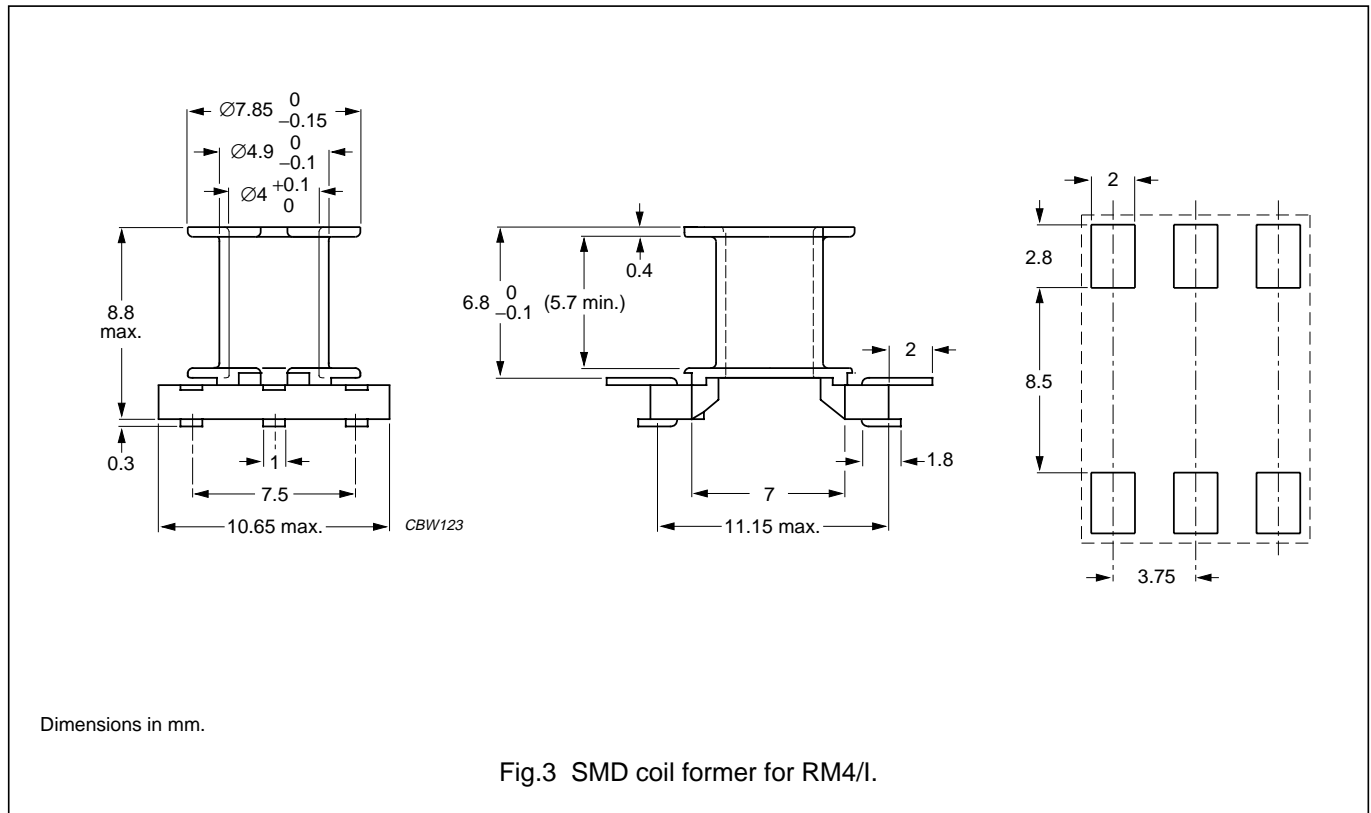

Winding data for RM4 coil former (SMD)

NUMBER OF SECTIONS	NUMBER OF SOLDER PADS	WINDING AREA (mm ²)	WINDING WIDTH (mm)	AVERAGE LENGTH OF TURN (mm)	TYPE NUMBER
1	6	8.4	5.75	19.8	CPVS-RM4-1S-6P

RM cores and accessories

RM4/I

MOUNTING PARTS

General data mounting clip with earth pin

ITEM	SPECIFICATION
Clamping force	≈5 N
Clip material	stainless steel (CrNi)
Clip plating	lead tin alloy (SnPb)
Solderability	"IEC 60068-2-20", Part 2, Test Ta, method 1
Type number	CLI/P-RM4/5/I

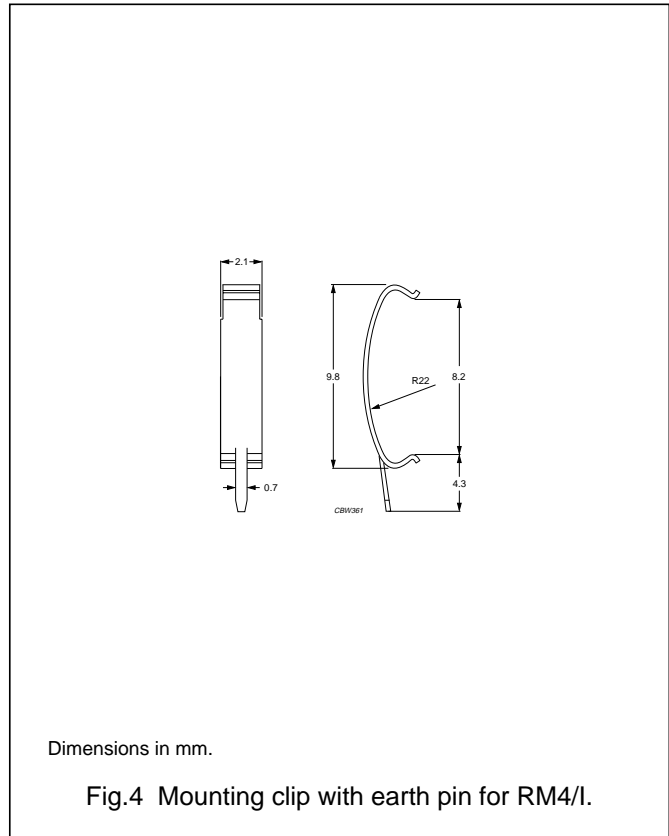

General data mounting clip without earth pin

ITEM	SPECIFICATION
Clamping force	≈5 N
Clip material	stainless steel (CrNi)
Type number	CLI-RM4/5/I

