

Ø 7.5 mm Film Dielectric Trimmers

MAXIMUM CONTACT RESISTANCE:

10 mΩ

MINIMUM INSULATION RESISTANCE:

10000 MΩ

CATEGORY TEMPERATURE RANGE:

PP

- 40 to + 70 °C

PE, PC, PTFE, PET

- 40 to + 85 °C

CLIMATIC CATEGORY (IEC 60068):

PP

40/070/21

PE, PC, PTFE, PET

40/085/21

MINIMUM STORAGE TEMPERATURE:

- 55 °C

RELATED SPECIFICATION:

IEC 60418-1 and 4

EFFECTIVE ANGLE OF ROTATION:

180°

OPERATING TORQUE:

 $C_{max} < 33 \text{ pF}$

1 to 15 mNm

 $C_{max} \geq 33 \text{ pF}$

1 to 25 mNm

MAXIMUM AXIAL THRUST:

2 N

FEATURES

- Housing diameter 7.5 mm
- For a basic grid of 2.54 mm (0.1") or 2.50 mm
- Top and bottom or top adjustment
- Vertical and horizontal versions
- Round or hexagonal head



APPLICATIONS

- For consumer and industrial equipment

DESCRIPTION:

The vanes of the trimmer are stacked on a sturdy plastic base. The color of the base indicates the maximum capacitance (see Electrical Data Table). The dielectric is a film of polypropylene (PP), polyethylene (PE), polycarbonate (PC), polytetrafluorethylene (PTFE), or polyethyleneterephthalate (PET) which supports the vanes in such a way that good stability is ensured and no microphony can occur.

Flux absorption between the vanes is prevented.

Cleaning with solvents is not advised.

Versions are available with either a vertical spindle, or a horizontal spindle (see dimensional outlines). Both versions have top adjustment by means of a screwdriver or trimming key and bottom adjustment by means of a key.

QUALITY LEVEL:

Sampling and data evaluation for quality level in accordance with "MIL-STD-105D" and "IEC 60410":

< 0.15 % major defects

< 0.65 % minor defects

Each capacitor is tested for minimum C_{min} and is also subjected to the full test voltage.

C_{min} / C_{max} :

1.4/5.5 to 3/50 pF

RATED VOLTAGE (DC):

250 V

TEST VOLTAGE (DC) FOR 1 MINUTE:

500 V

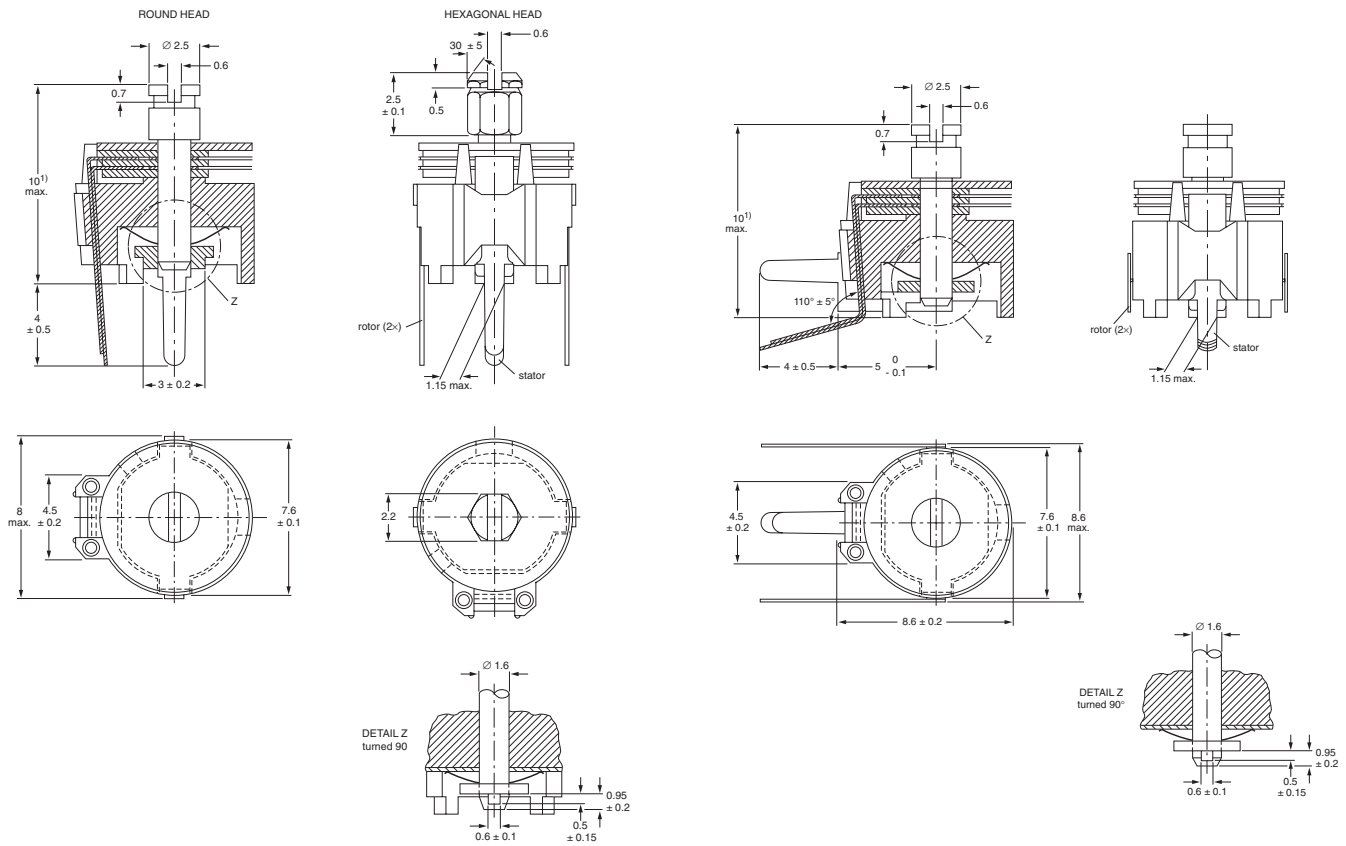

Trimmers 2281 808 series, vertical version

Trimmers 2281 808 series, horizontal version

Dimensions in millimeters.

ADJUSTMENT

For top adjustment a screwdriver or trimming key can be used; for bottom adjustment a key is required as shown below

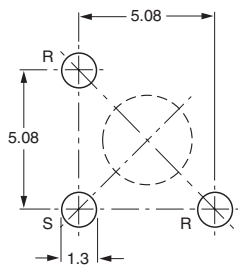

R = rotor, S = stator.

The large hole is for bottom adjustment and the diameter is determined by user's requirements.

Hole pattern

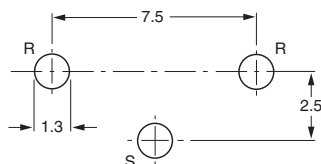

R = rotor, S = stator

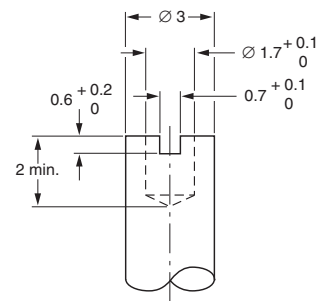

Bottom adjustment key

ORDERING INFORMATION

C_{min}/C_{max} (pF)	CATALOG NUMBER 2281 808 OR BFC2 808			
	VERTICAL VERSION			HORIZONTAL VERSION
	ROUND HEAD		HEXAGONAL HEAD	ROUND HEAD
	TOP AND BOTTOM ADJUSTMENT	TOP ADJUSTMENT ONLY	TOP AND BOTTOM ADJUSTMENT	TOP AND BOTTOM ADJUSTMENT
1.4/5.5	11558	00004	–	51558
2/9	00018	–	–	–
2/10	11109	00005	17109	51109
2/10	–	11004	–	–
2/15	11159	–	–	–
2/18	00016	–	–	–
2.5/20	–	11006	–	–
2.5/22	11229	00006	17229	51229
2.5/27	11279	–	–	51279
3/33	11339	–	–	–
3/40	11409	–	17409	51409
3/50	11509	–	17509	51509

MOUNTING

The trimmer can be mounted on printed-circuit boards with a grid of 2.50 mm or 2.54 mm and a minimum hole diameter of 1.25 mm.

PACKAGING

Bulk packaged in cardboard boxes lined with expanded plastic. For smallest packaging quantity (SPQ) see Electrical Data Table.

ELECTRICAL DATA

GUARANTEED MAX. $C_{min}/$ MIN. C_{max} AT 200 kHz (pF)	SPINDLE	SHAPE OF HEAD	FIG.	ADJ. MODE	DIEL.	TAN δ AT $C_{max} \times 10^{-4}$		TEMP. COEFF. ($10^{-6}/K$)	MIN. f_{res} at C_{max} (MHz)	COL. OF BASE	SPQ	CATALOG NUMBER 2281 or BFC2*
						1 MHz	100 MHz					
1.4/5.5	vertical	round	1	top + bottom	PE	≤ 10	≤ 25	-250 ± 350	850	grey	1400 808 11558
			1	top							1400 808 00004
	horizontal	round	2	top + bottom							1200 808 51558
2/9	vertical	round	1	top + bottom	PTFE	≤ 10	≤ 15	-150 ± 800	400	yellow	1400 808 00018
2/10	vertical	round	1	top + bottom	PP	≤ 10	≤ 25	-250 ± 800	480	yellow	1400 808 11109
			1	top							1400 808 00005
		hexag.	1	top							1400 808 17109
	horizontal	round	2	top + bottom							1200 808 51109
	vertical	round	1	top							PC	≤ 70
2/15	vertical	round	1	top + bottom	PP	≤ 10	≤ 25	-250 ± 600	450	blue	1400 808 11159
2/18	vertical	round	1	top + bottom	PTFE	≤ 10	≤ 15	-250 ± 350	350	green	1400 808 00016
2.5/20	vertical	round	1	top	PET	≤ 160	–	0 ± 1100	250	green	1000 808 11006
2.5/22	vertical	round	1	top + bottom	PP	≤ 10	≤ 25	-200 ± 500	350	green	1400 808 11229
			1	top							1400 808 00006
	vertical	hexag.	1	top							1400 808 17229
	horizontal	round	2	top + bottom							1200 808 51229
2.5/27	vertical	round	1	top + bottom	PC	≤ 70	–	-50 ± 500	350	red	1400 808 11279
	horizontal	round	2	top + bottom							1200 808 51279
3/33	vertical	round	1	top + bottom	PP	≤ 10	–	-250 ± 350	300	brown	1400 808 11339
3/40	vertical	round	1	top + bottom	PC	≤ 70	–	-50 ± 400	300	violet	1400 808 11409
	vertical	hexag.	1	top							1400 808 17409
	horizontal	round	2	top + bottom							1200 808 51409
3/50	vertical	round	1	top + bottom	PC	≤ 70	–	-50 ± 500	250	black	1400 808 11509
	vertical	hexag.	1	top							1400 808 17509
	horizontal	round	2	top + bottom							1200 808 51509

* ordering code for SAP system

TEST PROCEDURES AND REQUIREMENTS

IEC 60418-1 CLAUSE	IEC 60068 TEST METHOD	TEST	PROCEDURE	REQUIREMENTS
4.2		method of mounting	method A	
14		capacitance drift	after TC measurement	$\Delta C/C: \leq 1\%$ for $C_{max} < 40$ pF; $\Delta C/C: \leq 2.5\%$ for $C_{max} \geq 40$ pF
19		thrust	axial thrust of 2 N	$\Delta C/C: \leq 0.3\%$
21 21.1 21.2	Ua Ub	robustness of terminations: tensile bending	1 N 1 cycle	no damage no damage
22	Na	rapid change of temperature	1 cycle; 0.5 hours at lower and 0.5 hours at upper category temperature	$\Delta C/C: \leq 2\%$
23	T Ta Tb	soldering: solderability resistance to heat	solder bath immersion 3 mm; 235 °C; 2 s solder bath: 260 °C; 10 s	good wetting no mechanical damage no mechanical damage
24	Eb	impact bump	4000 ± 10 bumps; 40 g; 6 ms	$\Delta C/C: \leq 0.6\%$; no mechanical damage
25	Fc	vibration	frequency 10 to 55 Hz; amplitude 0.35 mm; 1.5 hours	$\Delta C/C: \leq 0.6\%$; no mechanical damage
26 26.1 26.2 26.3 26.5	B D Aa	climatic sequence: dry heat damp heat accelerated, first cycle cold damp heat accelerated, remaining cycles	16 hours at upper category temperature 1 cycle; 24 hours; + 40 °C; 95 to 100% RH 16 hours; - 40 °C 1 cycle; 24 hours; + 40 °C; 95 to 100 % RH	$\Delta C/C: \leq 4$ tan $\delta: \leq 10 \times 10^{-4}$ for $C_{max} < 27$ pF; tan $\delta: \leq 70 \times 10^{-4}$ for $C_{max} \geq 27$ pF; tan $\delta: \leq 80 \times 10^{-4}$ for $C_{max} \geq 40$ pF $R_{ins}: \geq 10000$ M Ω ; rotor contact R: ≤ 10 m Ω voltage proof: 500 V for 1 minute visual examination: no mechanical damage operating torque: 1 to 15 mNm for $C_{max} < 33$ pF; 1 to 25 mNm for $C_{max} \geq 33$ pF
27	Ca	damp heat steady state	21 days; + 40 °C; 90 to 95% RH	$\Delta C/C: \leq 5\%$ tan $\delta: \leq 30 \times 10^{-4}$ for $C_{max} < 27$ pF; tan $\delta: \leq 70 \times 10^{-4}$ for $C_{max} \geq 27$ pF; tan $\delta: \leq 80 \times 10^{-4}$ for $C_{max} \geq 40$ pF $R_{ins}: \geq 10000$ M Ω ; rotor contact R: ≤ 10 m Ω voltage proof: 500 V for 1 minute visual examination: no mechanical damage operating torque: 1 to 15 mNm for $C_{max} < 33$ pF; 1 to 25 mNm for $C_{max} \geq 33$ pF
29		mechanical endurance	10 cycles	$\Delta C/C: \leq 1.5\%$ $\Delta C/C$ after axial thrust: $\leq 0.3\%$; rotor contact R: ≤ 10 m Ω voltage proof: 500 V for 1 minute visual examination: no mechanical damage operating torque: 1 to 15 mNm for $C_{max} < 33$ pF; 1 to 25 mNm for $C_{max} \geq 33$ pF



Notice

Specifications of the products displayed herein are subject to change without notice. Vishay Intertechnology, Inc., or anyone on its behalf, assumes no responsibility or liability for any errors or inaccuracies.

Information contained herein is intended to provide a product description only. No license, express or implied, by estoppel or otherwise, to any intellectual property rights is granted by this document. Except as provided in Vishay's terms and conditions of sale for such products, Vishay assumes no liability whatsoever, and disclaims any express or implied warranty, relating to sale and/or use of Vishay products including liability or warranties relating to fitness for a particular purpose, merchantability, or infringement of any patent, copyright, or other intellectual property right.

The products shown herein are not designed for use in medical, life-saving, or life-sustaining applications. Customers using or selling these products for use in such applications do so at their own risk and agree to fully indemnify Vishay for any damages resulting from such improper use or sale.