

Global Connector Technology Ltd. - SIM4055 : SIM Card Connector, Push Push Type, 6 Pin, SMT, With Card Detect, 2.2mm Profile, With Locating Post

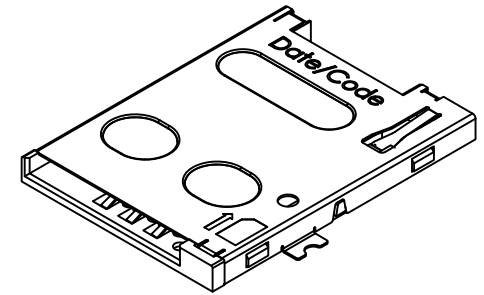

RECOMMENDED PCB LAYOUT
GENERAL TOLERANCE ±0.05
AS VIEWED FROM COMPONENT SIDE

- Solder Area
- Component Outline
- Keep Out Area

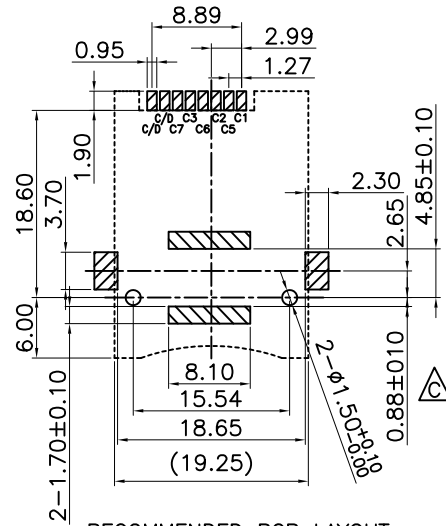
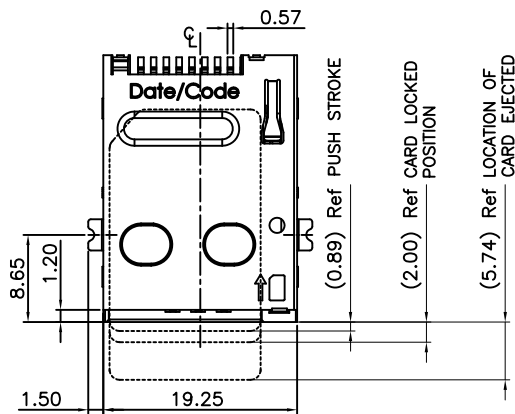
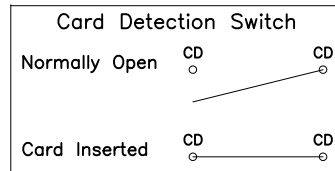

- C1---->VCC
- C2---->RST
- C3---->CLK
- C5---->GND
- C6---->Vpp
- C7---->I/O

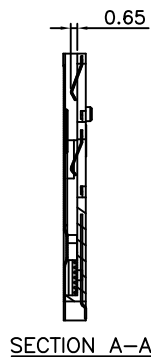

Ordering Grid

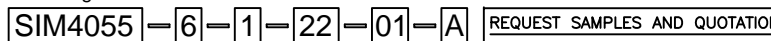

Specifications 规格:

Material 物料规格:

Plastic Housing 塑胶外壳: Hi-Temp Thermoplastic UL94V-0, Black 高温塑胶, 黑色
Contact Terminal 接触端子: Phosphor Bronze -磷青铜
Metallic Shell 金属外壳: Stainless Steel 不锈钢

Plating 电镀规格:

Contact Terminal plating 接触端子部分电镀:
Under-plating 底层电镀: 50u" Min. Nickel all over 全部镀镍最少 50u"
Contact Area 接触部分: 15u" Gold 镀金15u"
Soldering Area 焊接部分: Gold Flash 镀金
Switch Terminal plating 开关端子部分电镀:
Under-plating 底层电镀: 50u" Min. Nickel all over 全部镀镍最少 50u"
Contact Area 接触部分: 15u" Gold 镀金15u"
Soldering Area 焊接部分: Gold Flash 镀金
Metallic Shell plating 金属外壳电镀:
Under-plating 底层电镀: 50u" Min. Nickel all over 全部镀镍最少 50u"
Soldering Area 焊接部分: 2u" Selective Gold on one side 单面镀金2u"

Electrical 电气规格:

Voltage rating 电压额定值: 5 V AC (R.M.S.) Max.
Current Rating 电流额定值: 0.5A DC
Operating Temperature 工作温度: -55°C to +105°C
Contact Resistance 接触电阻值: 80mW Max.
Insulating Resistance 绝缘电阻值: 500MW Min. (Apply 施加500VDC)
Dielectric Withstand Voltage 绝缘耐压: No Discharge or Flash over 没有放电或火花 (Apply 250VAC for 1 minute 施加250VAC共1分钟)

Mechanical 机械规格:

Durability 耐久性: 5,000 cycles 5000 次插拔
Insertion / Withdrawal Force 插拔力: 13.8 N Max.

By	PKN	PN	AE	SA	SA	SA	SA
DETAIL	DRAWING RELEASE	CORRECTION TO PIN OUT ERROR	PCB LAYOUT & TERMINAL DETAIL UPDATED	PCB LAYOUT AMENDED	SOLDERING AREA PLATING UPDATE	PACKING LAYOUT UPDATE	ECN: SIM4055-001
REV DATE	A 09/04/08	B 04/11/08	C 09/09/09	D 23/04/10	E 14/05/10	F 02/09/10	G 12/01/11



Tolerances (Except as noted)	Part Number:-	Date:-
Dimensions in mm	SIM4055	09 APR 08
X.X ± 0.20 X.X° ± 3° X.XX ± 0.15 X.X° ± 2° X.XXX ± 0.05 X.XX° ± 1°	Description:-	
	SIM CARD CONNECTOR, PUSH PUSH TYPE, 6 PIN, SMT, WITH CARD DETECT, 2.2MM PROFILE, WITH LOCATING POST	
Third Angle Projection	© THIS DRAWING IS CONFIDENTIAL AND MUST NOT BE COPIED OR DISCLOSED WITHOUT WRITTEN CONSENT	

GCT

www.globalconnectortechology.com

Scale NTS	Revision G	Material See Note	Drawn by PKN	E & OE	Sheet No. 1/2
-----------	------------	-------------------	--------------	--------	---------------

A
B
C
D
E
F
G
H

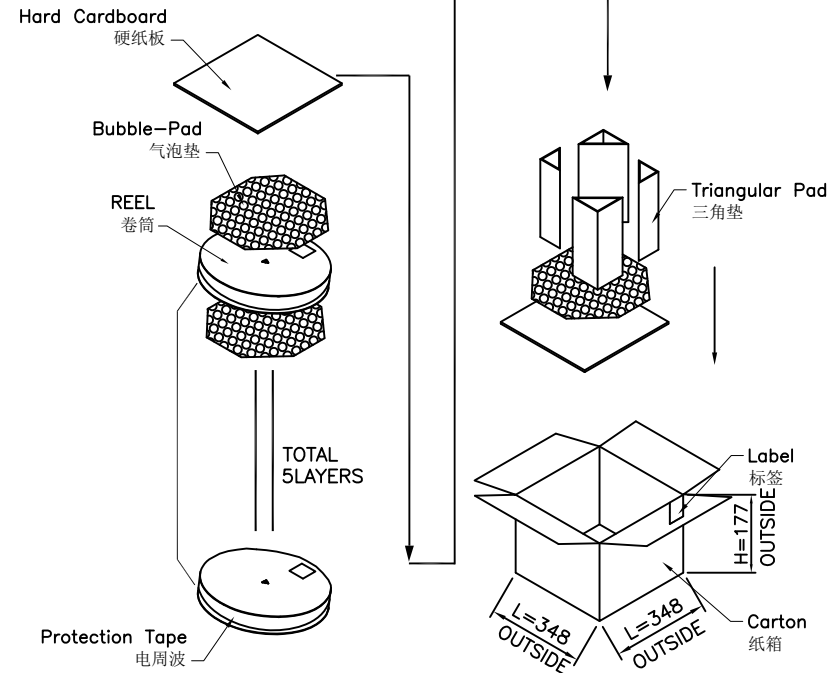
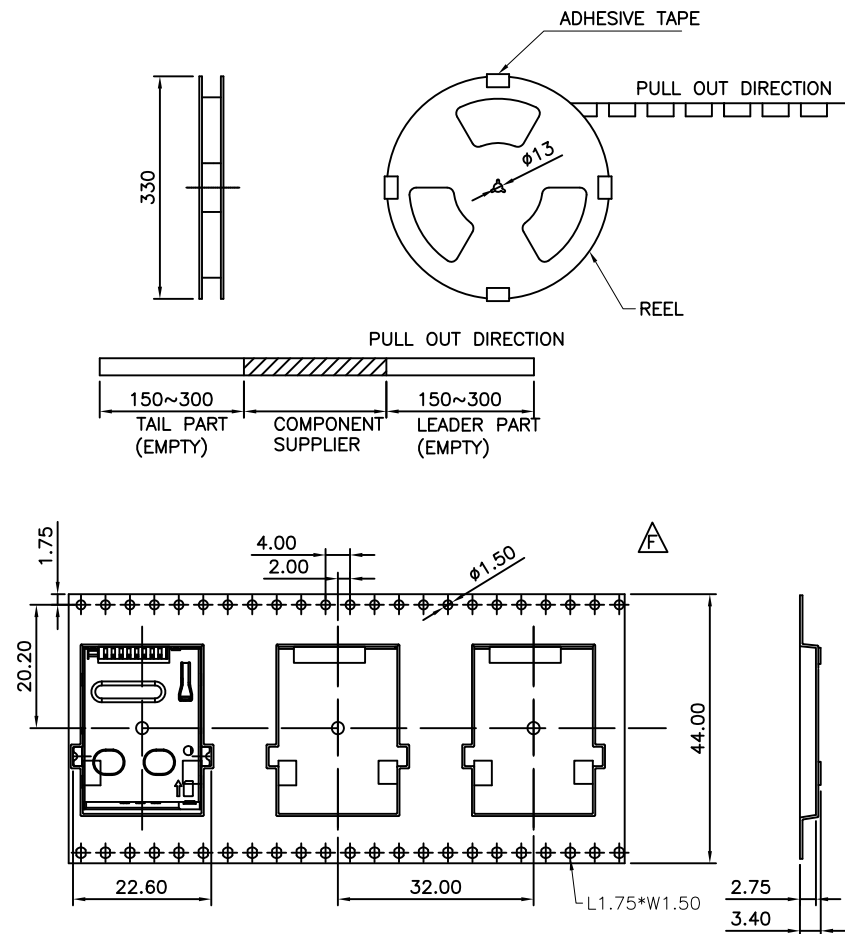

Notes注意:

- The 1st & Last 200-300mm at the leading & tail of the CARRY TAPE will not be used. CARRY TAPE 前部分与尾部分各留出200-300mm长度不装产品
- Each cavity will hold 1pc. Placement methods are shown in the diagrams. 每穴放置1pc产品, 放置方式如图所示
- After the packing machine filled the REEL, tangle the REEL one more loop with protection tape, stick adhesive tape on the four quadrants of the REEL, to avoid out-spreading. Stick 1pc. of label on each REEL. 包装机包好后, 再缠上一圈电周波, 在REEL的四个极点上胶带, 以防止REEL张开, 每REEL贴1PC标签
- Use sticking cover tape to seal carrier tape. 使用自粘式胶带 \triangle
- Firstly put a water-proof bag at the bottom of the carton box, then place 1pc. of hard cardboard on top, following with 1pc. of bubble-pad, and at the four corners, place the triangular pads, then place those filled REEL into the center of the carton box. Between the REEL, place 1pc. of bubble-pad as the separator, until 5pc. of REEL are filled in the box. Then place 1pc. of bubble-pad & 1pc. of hard cardboard on top, close the carton by plastic tape lastly. 先在纸箱底部套上一防水袋, 再垫上1pc硬纸板后再垫上1pc气泡垫, 四角垫上三角垫, 度然后把装好产品的REEL放进纸箱中, 每REEL之间隔1pc气泡垫, 依次把5 REEL产品放到纸箱中, 上面再垫上各1pc气泡垫及硬纸板, 最后用胶带封箱
- The peel-off force between the COVER TAPE & CARRY TAPE is: 0.1N-0.7N (variation within 0.3N). Peel-off angle: 165-175 degree; Speed of peel-off: 250mm-300mm/min. COVER TAPE 与 CARRY TAPE 剥离力: 0.1N-0.7N (跳动量在0.3N以内) 剥离角度: 165-175度; 剥离速度: 250mm-300mm/分钟

By	PKN	PN	AE	SA	SA	SA	SA
DETAIL	DRAWING RELEASE	CORRECTION TO PIN OUT ERROR	PCB LAYOUT & TERMINAL DETAIL UPDATED	PCB LAYOUT AMENDED	SOLDERING AREA PLATING UPDATE	PACKING LAYOUT UPDATE	ECN: SIM4055-001
REV DATE	A 09/04/08	B 04/11/08	C 09/09/09	D 23/04/10	E 14/05/10	F 02/09/10	G 12/01/11



Tolerances (Except as noted)	Part Number:-	Date:-
Dimensions in mm	SIM4055	09 APR 08
	Description:-	
	SIM CARD CONNECTOR, PUSH PUSH TYPE, 6 PIN, SMT, WITH CARD DETECT, 2.2MM PROFILE, WITH LOCATING POST	
Third Angle Projection	THIS DRAWING IS CONFIDENTIAL AND MUST NOT BE COPIED OR DISCLOSED WITHOUT WRITTEN CONSENT	

GCT

www.globalconnectortechonology.com

Scale NTS	Revision G	Material See Note	Drawn by PKN	Sheet No. 2/2
-----------	------------	-------------------	--------------	---------------