



ALL RIGHTS RESERVED. NO PORTION OF THIS PUBLICATION, WHETHER IN WHOLE OR IN PART CAN BE REPRODUCED WITHOUT THE EXPRESS WRITTEN CONSENT OF SPC TECHNOLOGY.

SPC-F005.DWG

REVISIONS

DOC. NO. SPC-F005 \* Effective: 7/8/02 \* DCP No: 1398

DCP #	REV	DESCRIPTION	DRAWN	DATE	CHECKD	DATE	APPRVD	DATE
1891	A	RELEASED	EO	06/27/06	SA	7/25/06	HO	7/25/06



RoHS Compliant

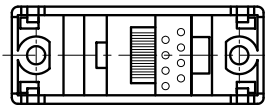
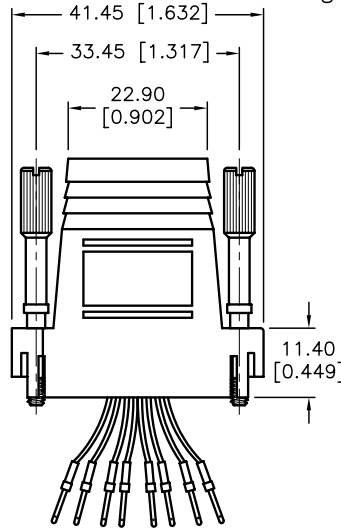
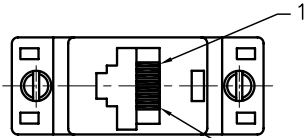
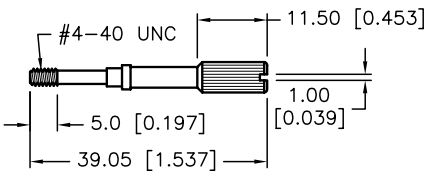
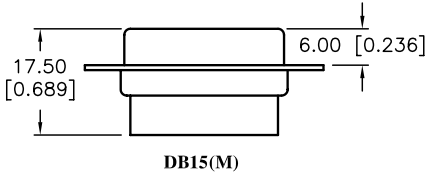
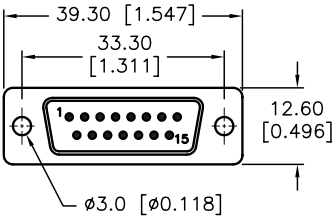

FRONT VIEW OF 8P8C TELEPHONE JACK (W/KEYED TYPE)

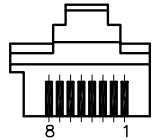

WIRE SYSTEM

1	2	3	4	5	6	7	8
BLUE	ORANGE	BLACK	RED	GREEN	YELLOW	BROWN	GRAY(WHITE)

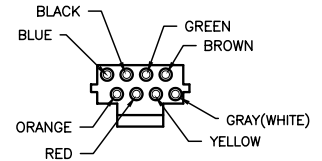
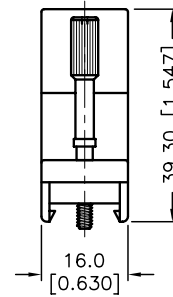

SPECIFICATIONS:

- D-Sub Connector: 15pin Male, Tin-Plated Shell with Black Color Insulator
- Contact
  - D-Sub: Brass, Gold-Plated
  - RJ45: Brass, Gold-Plated
- Body: ABS, Beige Color
- Thumb Screw: Steel, Nickel-plated
- Electronic Wire: UL1061, 26 AWG

DISCLAIMER: ALL STATEMENTS AND TECHNICAL INFORMATION CONTAINED HEREIN ARE BASED UPON INFORMATION AND/OR TESTS WE BELIEVE TO BE ACCURATE AND RELIABLE. SINCE CONDITIONS OF USE ARE BEYOND OUR CONTROL, THE USER SHALL DETERMINE THE SUITABILITY OF THE PRODUCT FOR THE INTENDED USE AND ASSUME ALL RISK AND LIABILITY WHATSOEVER IN CONNECTION THEREWITH.

TOLERANCES:  
Unless Otherwise Specified  
.X ±0.2 [0.008]  
.XX ±0.12 [0.005]

DRAWN BY:	DATE:
EKLAS ODISH	06/27/06
CHECKED BY:	DATE:
SAMI ALNADI	7/25/06
APPROVED BY:	DATE:
HISHAM ODISH	7/25/06

DRAWING TITLE: <b>Telephone Adapter, DB15 Male to RJ45, 8 Conductors</b>			
SIZE	DWG. NO.	ELECTRONIC FILE	REV
A	SPC19790	84K8554.DWG	A
SCALE: NTS	U.O.M.: mm [INCHES]	SHEET: 1 OF 1	