



ALL RIGHTS RESERVED. NO PORTION OF THIS PUBLICATION, WHETHER IN WHOLE OR IN PART CAN BE REPRODUCED WITHOUT THE EXPRESS WRITTEN CONSENT OF SPC TECHNOLOGY.

SPC-F005.DWG

REVISIONS

DOC. NO. SPC-F005 * Effective: 7/8/02 * DCP No: 1398

DCP #	REV	DESCRIPTION	DRAWN	DATE	CHECKD	DATE	APPRVD	DATE
1876	A	RELEASED	EO	03/21/06	TL	05/15/06	HO	05/15/06

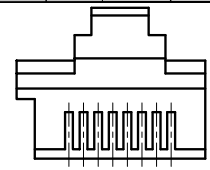
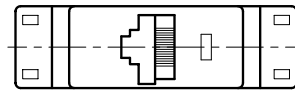

FRONT VIEW OF 8P8C TELEPHONE JACK (W/KEYED TYPE)

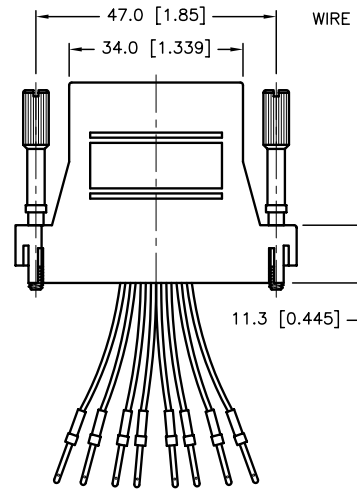
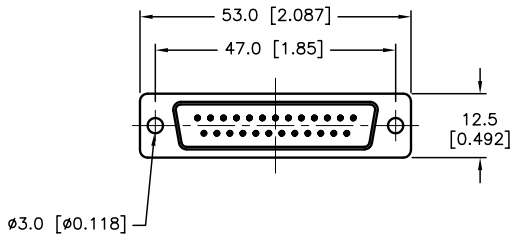

WIRE SYSTEM: 1 2 3 4 5 6 7 8
BLU ORG BLK RED GEN YEL BRO GRY(WHT)

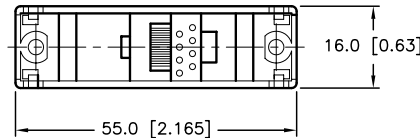
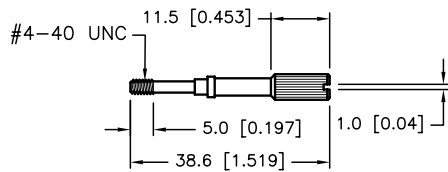
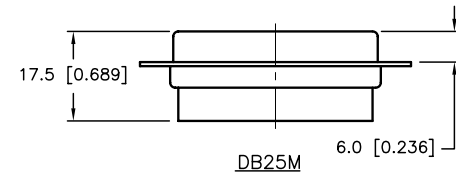
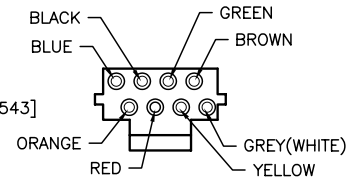
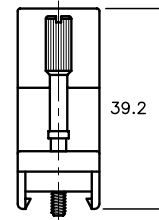

SPECIFICATION:

- D-Sub Connector: Tin-Plated Shell with Black Color Insulator
- Contact:
 - a- D-Sub: Brass, Gold-Plated
 - b- RJ45: Brass, Gold-Plated
- Body: ABS
- Thumb Screw: Steel, Nickel-plated
- Electronic Wire: UL1061, 26AWG

PART NO.	COLOR
SPC15464	BLACK
SPC15279	BLUE
SPC15222	RED
SPC15287	GREEN
SPC15141	YELLOW

DISCLAIMER:
ALL STATEMENTS AND TECHNICAL INFORMATION CONTAINED HEREIN ARE BASED UPON INFORMATION AND/OR TESTS WE BELIEVE TO BE ACCURATE AND RELIABLE. SINCE CONDITIONS OF USE ARE BEYOND OUR CONTROL, THE USER SHALL DETERMINE THE SUITABILITY OF THE PRODUCT FOR THE INTENDED USE AND ASSUME ALL RISK AND LIABILITY WHATSOEVER IN CONNECTION THEREWITH.

TOLERANCES:

Unless Otherwise Specified
.X ±0.2 [0.008]
.XX ±0.12 [0.005]

DRAWN BY:	DATE:
EKLAS ODISH	03/21/06
CHECKED BY:	DATE:
THOMAS LEE	05/15/06
APPROVED BY:	DATE:
HISHAM ODISH	05/15/06

DRAWING TITLE:
RoHS Compliant ADAPTER KIT, DB25M TO RJ45

SIZE	DWG. NO.	ELECTRONIC FILE	REV
A	TA-692	TA-692.DWG	A
SCALE: NTS		U.O.M.: mm [INCHES]	SHEET: 1 OF 1