

BestCap® Supercapacitors

The BestCap® series of electrochemical supercapacitors offer excellent high power pulse characteristics based upon the combination of very high capacitance and ultra low ESR in the milliohm region.

Based on a unique patented aqueous chemistry and an innovative design, the system offers high capacitance, even with short pulse duration regimes such as in GSM and GPRS based systems.

Used in conjunction with battery packs, BestCap® improves the voltage performance for high current pulses, resulting in higher PA efficiency and longer battery talk-time. BestCap® can also be used to boost instantaneous power availability in non-battery electronic applications where low level constant currents need to be supplemented by high current pulses.

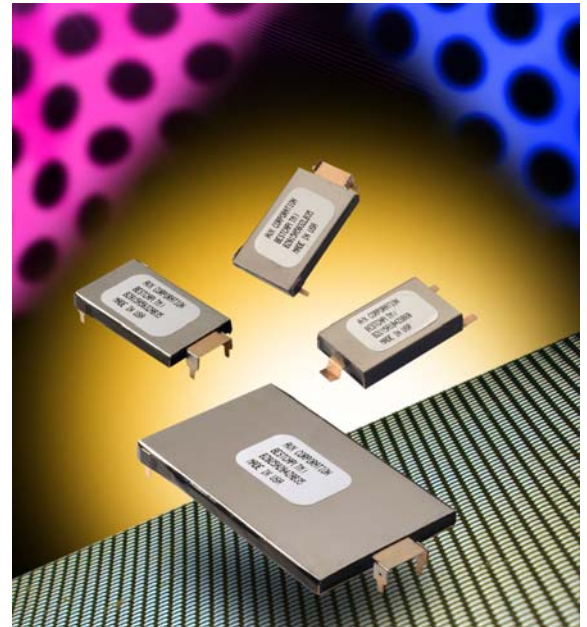

Characteristics

AVX Catalog Part Number:	BZ015B603ZLB
Part Size (mm):	28 x 17 x 4.8 Max*
Temperature Range:	-20°C to 70°C
Rated Voltage:	5.5 V
Capacitance (+80%/-20%):	60 mF
Leakage Current:	10 μ A Max
ESR (1 kHz, +20%/-50%):	80 m Ω

* - Does not include 0.55 +/-0.2 mm standoff from PCB.

Applications

RF Modems

Mainframe Computer Decoupling

Memory Back-up

Hybrid Battery Packs

Audio System “Base Line Stiffeners”

Camera Flash Systems

UPS

Switch Mode Power Supplies

Wireless Alarm Systems

Products / Systems based on GSM, DSC1800, PCS, DECT...

PCB Layout

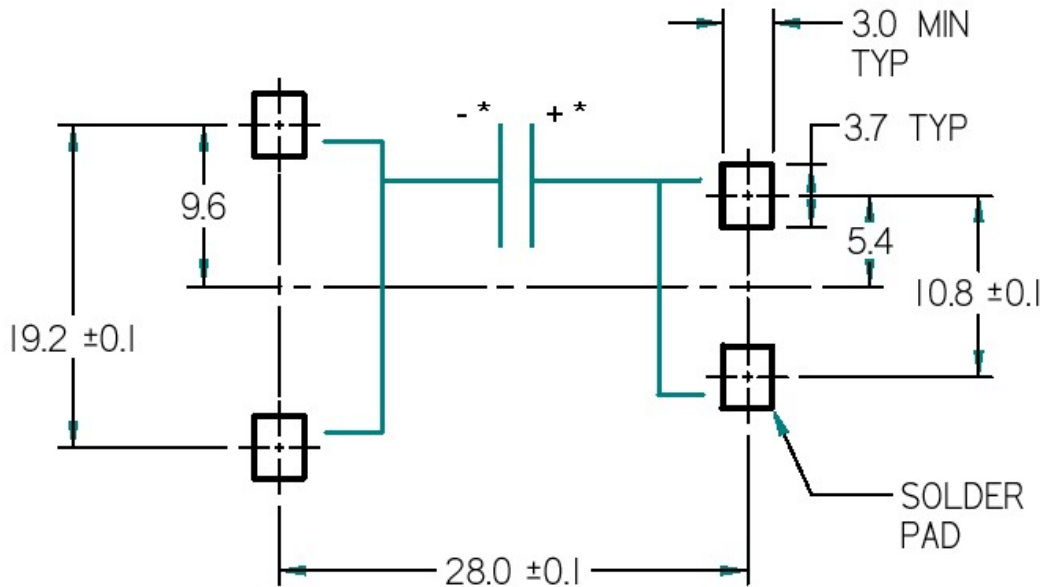

NOTE: BestCap is non-polar. However, for applications in which EMI is critical, AVX recommends the indicated polarity.

SUGGESTED PCB LAYOUT

All dimensions in mm.



USA

AVX Myrtle Beach, SC
Corporate Offices
Tel: 843-448-9411
Fax: 843-448-1943

AVX Southwest, AZ
Tel: 480-539-1496
Fax: 480-539-1501

AVX Northwest, WA
Tel: 360-669-8746
Fax: 360-669-8751

AVX South Central, TX
Tel: 972-669-1223
Fax: 972-669-2090

AVX North Central, IN
Tel: 317-848-7153
Fax: 317-844-9314

AVX Southeast, NC
Tel: 919-878-6357
Fax: 919-878-6462

AVX Northeast, MA
Tel: 508-485-8114
Fax: 508-485-8471

AVX Canada
Tel: 905-564-8959
Fax: 905-564-9728

AVX Mid-Pacific, CA
Tel: 952-974-9155
Fax: 952-974-9179

EUROPE

AVX Limited, England
European Headquarters
Tel: ++44 (0)1252 770000
Fax: ++44 (0)1252 770001

AVX GmbH, Germany – Elco
Tel: ++49 (0) 2741 2990
Fax: ++49 (0) 2741 299299

AVX S.A., France
Tel: ++33 (1) 69.18.46.00
Fax: ++33 (1) 69.28.73.87

AVX srl, Italy
Tel: ++390 (0)2 614571
Fax: ++390 (0)2 614 2576

AVX GmbH, Germany
Tel: ++49 (0) 8131 9004-0
Fax: ++49 (0) 8131 9004-44

AVX sro, Czech Republic
Tel: ++420 (0)467 558111
Fax: ++420 (0)467 523010

ASIA-PACIFIC

AVX/Kyocera, Singapore
Asia-Pacific Headquarters
Tel: (65) 258-2833
Fax: (65) 350-4880

AVX/Kyocera, China
Tel: (86) 21-6249-0314-16
Fax: (86) 21-6249-0313

AVX/Kyocera, Hong Kong
Tel: (852) 2-363-3303
Fax: (852) 2-765-8185

AVX/Kyocera, Malaysia
Tel: (60) 4-228-1190
Fax: (60) 4-228-1196

AVX/Kyocera, Korea
Tel: (82) 2-785-6504
Fax: (82) 2-784-5411

Elco, Japan
Tel: 045-943-2906/7
Fax: 045-943-2910

AVX/Kyocera, Taiwan
Tel: (886) 2-2696-4636
Fax: (886) 2-2696-4237

Kyocera, Japan – AVX
Tel: (81) 75-604-3426
Fax: (81) 75-604-3425

Kyocera, Japan – KDP
Tel: (81) 75-604-3424
Fax: (81) 75-604-3425