

Micromotor Catalogue



Contact **Information**

→ **Crouzet Direct**

- For technical support, product information, to make an enquiry or place an order:

Telephone: +44 (0) 1256 318900

Email: motors@crouzet.co.uk

→ **Crouzet on the internet**

- To get the latest news on our products and services
- To download detailed technical information sheets

www.crouzet.co.uk



→ **Specialist Motor distribution**

- For quick delivery of selected standard motors and locally adapted products
- See pages 4 and 5 for details of your nearest Crouzet distributor.

Contents

Support locations	04
New products	06
Motor range overview	08
Applications	10
Crouzet product ranges	12
How to order	13

MOTORS QUICK REFERENCE

 D.C. motors	1
 D.C. brushless motors	2
 Motomate	3
 Synchronous motors	4
 Stepper motors	5
 Linear motors	6
 Fans	7

SELECTION AND TECHNOLOGY GUIDES

D.C. motors	16
D.C. brushless motors	70
Motomate	86
Synchronous motors	94
Stepper motors	138
Fans	178
Index by part number and product family	188
General conditions of sale	195

Support **Locations**

→ **Crouzet on the internet**

- To get the latest news on our products and services
- To download detailed technical information sheets

www.crouzet.co.uk

→ **Crouzet Hotline**

- For technical support, product information, to make an enquiry or place an order:

Telephone: +44 (0) 1256 318900

Email: motors@crouzet.co.uk

Crouzet Ltd

Intec 3
Wade Road
Basingstoke
Hampshire
RG24 8NE



United Kingdom



Specialist Distributor

Camis Electronics Ltd

Platts Road
Amblecote
Stourbridge
West Midlands
DY8 4YR

Tel: 01384 441402

Fax: 01384 370354

Email: sales@camis.demon.co.uk

Website: www.camis.demon.co.uk

Specialist Distributor

MicroDrives Ltd

Woodlands
South Hanningfield Road
Rettendon common
Chelmsford
Essex
CM3 8HD

Tel: 01245 403100

Fax: 01245 403101

Email: microdrives@talk21.com

New products

Motomate

The NEW Motomate system is designed to save you money by greatly reducing the time and effort needed to integrate it into your application. Motomate combines a brushless motor, movement and position control, together with full logic controller functionality in a single compact unit. This eliminates all of the hard work and compatibility problems usually associated with having to integrate separate components.

Benefits to you

- Brushless DC motor with integrated logic and motion controller
- Guaranteed compatibility and ease of configuration
- Reliability and safety built-in
- Additional logic inputs and outputs
- High torque, high efficiency and low noise
- Communications options

Benefits to your customer

- Zero down time
- Long life with low noise and low running costs
- Compact size
- Easily reconfigured grows with the installation

For more information, see page 85

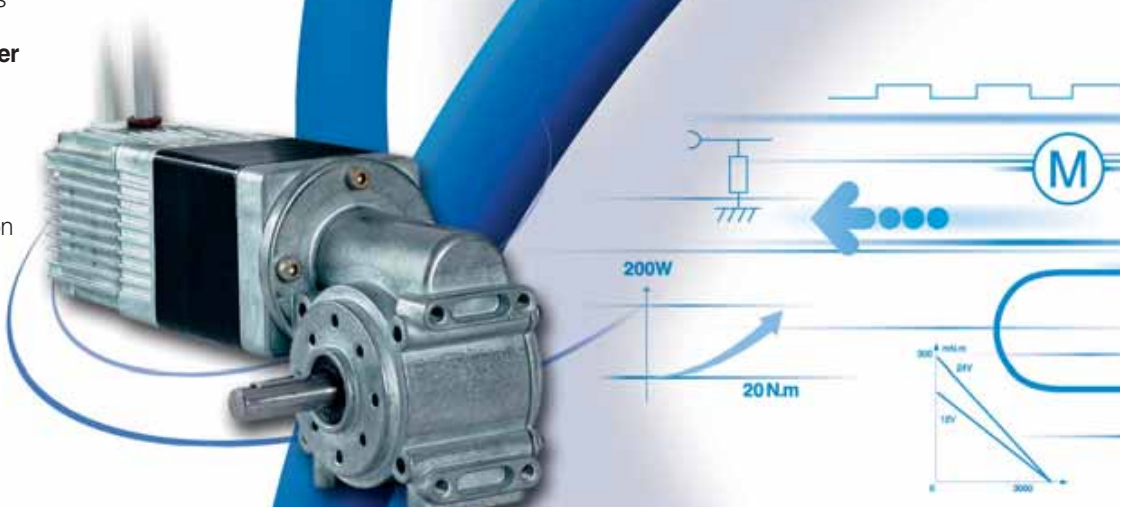

Choose your functions

Construct your program

Test your installation

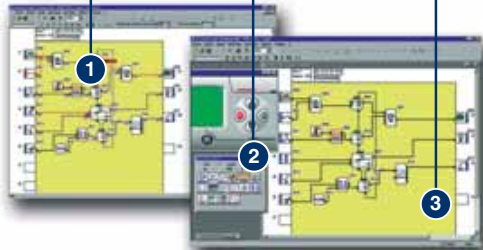

4 functions pre-programmed specifically for Motomate...



HIGH SPEED COUNTER
Used to count motor pulses, indicate position and calculate speed



TIMER
Used to set a time delay between 2 movements



MOVEMENT
Used to reach a target position following speed ramps



MOTOR MULTIPLEXER
Used to group the On/Off, direction and speed outputs for several movement steps



Brushless DC motors

The NEW brushless DC motor range offers very high levels of performance in a very small package.

This all-in-one solution combines brushless motor technology integrated with advanced electronics to give speed control, dynamic braking and automatic protection.

Benefits to you

- All-in-one solution with motor, speed control and overload protection
- Easy to integrate - no compatibility problems
- Ultra-compact package
- Easy to set up and use
- Encoder output for positioning control
- High starting torque and high efficiency
- Low noise and long life

Benefits to your customer

- Small size
- Zero maintenance
- Long life and low power consumption
- Overload protection built-in

For more information, see page 69



Linear motors

The NEW linear motor range provides a powerful and precise output force whilst remaining incredibly easy to control.

A choice of either reversible synchronous or stepper motor technologies means that you can select the best control system to suit the application.

Benefits to you

- Choice of technology - stepper or synchronous drive
- High output force and precise positioning
- Built-in shaft anti-rotation device for ease of installation
- Simple robust construction

Benefits to your customer

- Low noise
- Zero maintenance
- Low power consumption

For more information, see page 169

Motor range overview

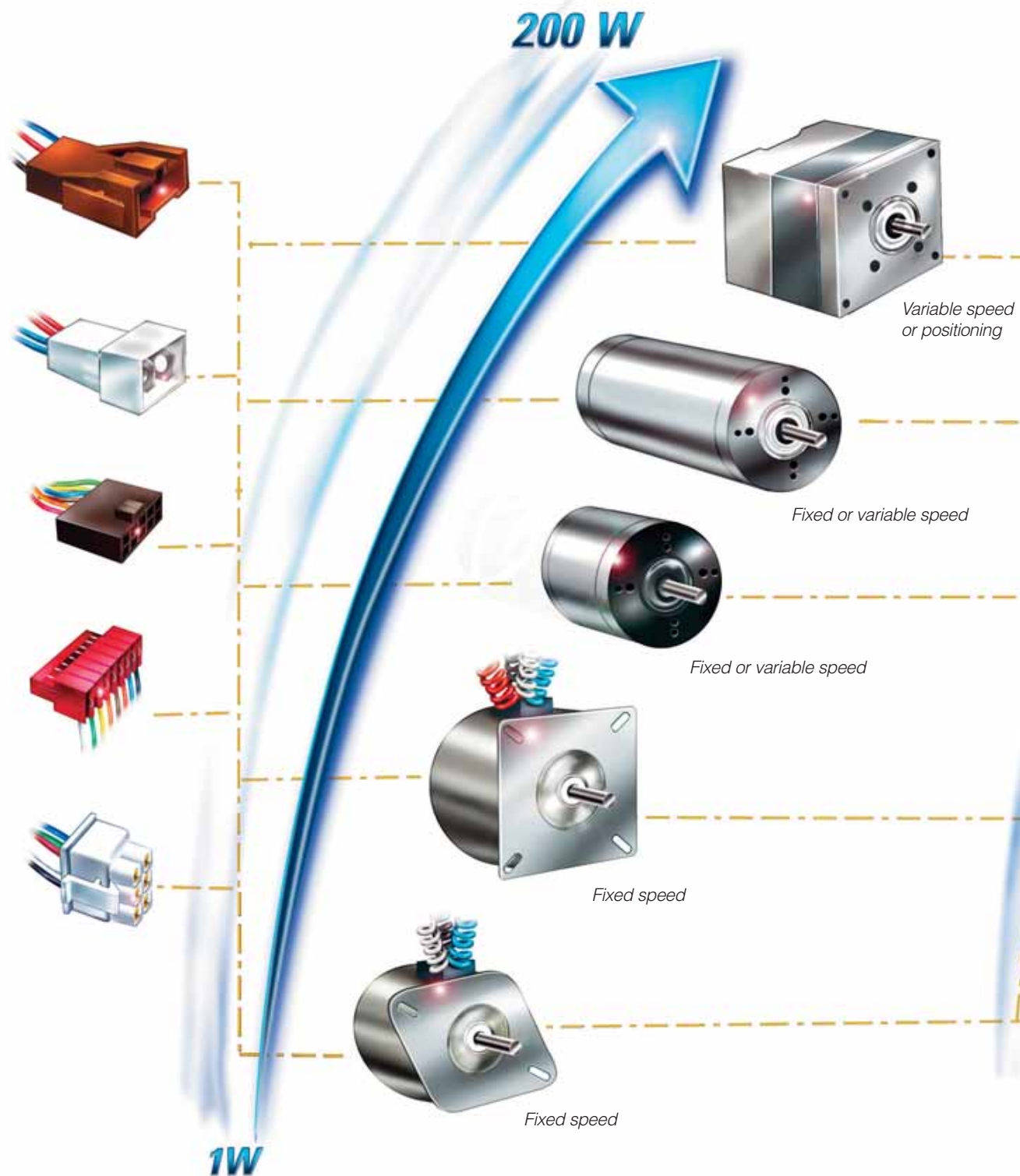

Motor options:

- Special output shafts
- Pinion or bush on output shaft
- Special supply voltages
- Special wire lengths
- Special output bearings
- Optional encoder
- Special mounting plate
- Customised electronics
- Special construction materials
- Special connectors
- Special IP rating



Gearbox options:

- Special output shafts
- Special ratios
- Special gear wheel material
- Special output bearings
- Special mounting plate
- Special construction materials
- Special IP rating

Example motor



Brushless DC motor
with special connector

Applications

Controlling shock absorber rods



Stepper motors

- High-torque, waterproof stepper motors to adjust the firmness of a car's suspension units depending on the driver's driving style, ensuring total comfort and safety.
- The solution developed takes account of environmental constraints and is extremely compact thanks to its custom design.

Managing the control of lubrication pumps



Geared stepper motor

- A motor solution controlled by a dedicated electronic card for controlling bus and truck lubrication systems.
- The electronics interpret and take account of the climatic conditions as well as the characteristics of the lubricants used.
- Once the system is on-board, downtimes associated with maintenance are largely eliminated.

Controlling industrial valves



Synchronous geared motor

- The geared motor controls valve opening and closing for easy operation, such as the tap solution developed for a customer specification.

Adjusting the flow rate in wall-mounted boilers



Linear motor

- Complete motor unit with control mechanism and connector for smooth control of gas supply. This offers the boiler user many advantages: safety of use, silent operation, smaller dimensions, lower consumption levels and reduced NOx emissions.
- From the installer's point of view, the product boasts a long, maintenance-free service life, it is easily interchangeable and is standard across an entire boiler range.

Controlling door mechanisms



Motomate - Brushless motor with integrated logic controller

- Motomate controls the opening and closing torque to ensure user safety. Motomate offers shorter development times, easy integration associated with more compact dimensions and fewer maintenance operations, all thanks to its dedicated all-in-one design.

Adjusting the temperature of wall-mounted boilers



Synchronous geared motor

- The geared motor controls the water valve so that it opens and closes smoothly, thus eliminating the effect of water hammer and achieving a more refined control.

Shutter control mechanism



Stepper motor

- The geared stepper motor fitted with a special control mechanism adjusts shutter opening and closing operations.
- The shutter orientation ensures a consistent temperature within a specific area. The electronics analyse the relative humidity and control the shutters, avoiding a build-up of condensation on windows and thus reducing the need for frequent cleaning.

Tailgate closure mechanism



DC motor

- Motorisation, when fitted with a front end shield, of an output shaft and a pinion dictated by the customer interface.
- Gentle, assisted closure of the car boot.
- Silent, low-speed operation, synonymous with quality and driver comfort .

Crouzet product ranges



Motors

DC motors, brushless motors, Linear motors, Synchronous motors, Stepper motors, Motomate, Fans



Control

Timers, Logic controller, Counters, Ratemeters, Control relays, Solid state relays, I/O modules, Temperature controllers, Machine Safety, Control units for burners



Pneumatic

Electro-pneumatic miniature control valves, Intrinsically safe miniature solenoid valves, Multi-fluid solenoid valves, Position detectors, Man / Machine Interface components, Pressure switches and amplifiers, Pneumatic logic components, Vacuum handling components



Switches and sensors

Limit switches, Microswitches, Inductive proximity sensors, Capacitive proximity sensors, Photoelectric sensors, Readout modules



Command and signalling

Control and signalling components, Terminals, Selector switches, Custom designed control units

Senior products

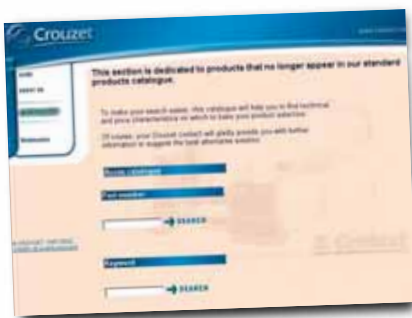

www.crouzet.com/olc

To meet your maintenance requirements, the senior products site contains a selection of products which no longer appear in this catalogue.

To assist your search, this web space will help you find the technical and price characteristics to enable you to procure these products.

And of course, your Crouzet contact is always on hand to help fill in the information required, or to suggest the optimum replacement solution.

How to order



Catalogue products, not in stock
Give the reference in black and the additional characteristics below.

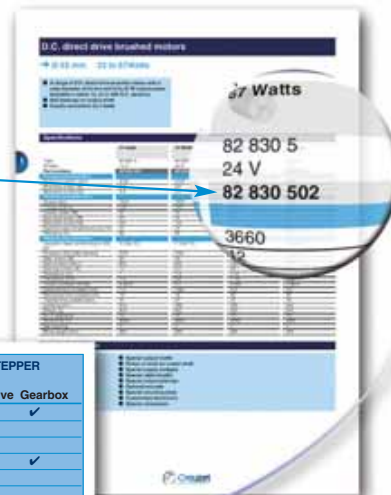

	DC		SYNCHRONOUS, NON-REVERSING		SYNCHRONOUS, REVERSING		STEPPER	
	Direct drive	Gearbox	Direct drive	Gearbox	Direct drive	Gearbox	Direct drive	Gearbox
Type	✓	✓	✓	✓	✓	✓	✓	✓
Voltage	✓	✓	✓	✓	✓	✓	✓	✓
Output speed	✓	✓	✓	✓	✓	✓	✓	✓
Option		✓			✓	✓		✓
Direction of rotation			✓	✓	✓	✓		
Frequency			✓	✓	✓	✓		
Motor shaft							✓	
Reduction ratio								✓
Number of phases								✓

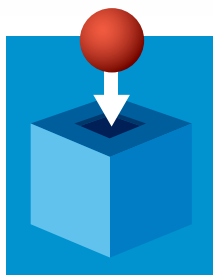

Adaptable product

This symbol indicates that the product can be adapted to your needs. Please contact us for more details and to discuss your application.

Warning:







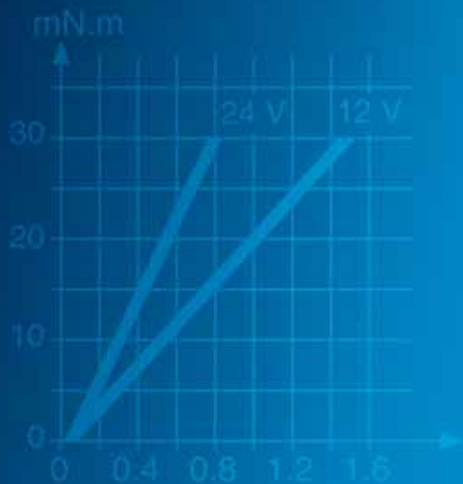
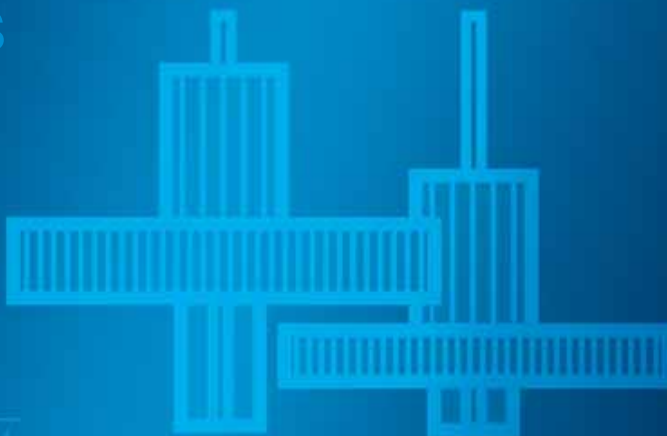



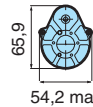
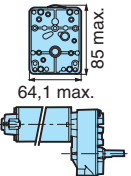



The technical information in this catalogue is given for information only and does not constitute a contractual obligation. CROUZET Automatismes and its subsidiaries reserve the right to make any modifications without notice. It is essential to contact us for any special use/application of our products, and it is the responsibility of the purchaser to check, in particular using all appropriate tests, that the product used is suitable for the application. Our guarantee may under no circumstances be invoked, nor our responsibility sought for any application of our products such as, amongst others, modification, addition, use in combination with other electrical or electronic components, circuits or mounting systems, or any other inappropriate equipment or substance which has not been expressly approved by us prior to the finalisation of the sale.

D.C. motors

D.C. motors



Guide to selecting D. C. motors











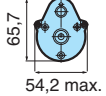

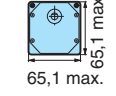
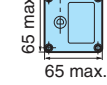
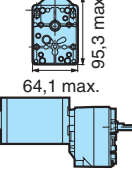

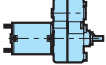

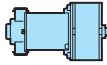







Gearbox		Max. torque (Nm)		0.5		1.2	
		Type of gearbox		81 012	81 021	81 032	
Motors direct drive (Nm)							
Usable Power (W)	Nominal torque (Nm)	Nominal speed (rpm)	Supply voltage (V)	Motor type dimensions (mm)			
3	7.7	3700	12 24	▶ p.22 82 860 0 Ø 32 	▶ p.34 82 862  1.5 ... 441 rpm	▶ p.36 82 861  0.36... 430 rpm	
8.7	41.5	2000	12	▶ p.24 82 810 0 Ø 42 			▶ p.38 82 812  20... 100 rpm
9.4	45		24				
12	45	2580	12	▶ p.26 82 810 5 Ø 42 			
13		2750	24				
15.6	75	2000	12	▶ p.24 82 800 0 Ø 42 			▶ p.38 82 802  20... 100 rpm
15.7			24				
20	70	2670	12	▶ p.26 82 800 5 Ø 42 			
22		3070	24				
20	70	2670	12	▶ p.28 82 800 8 Ø 42 			
22			3070	24			
27	172	1500	12 24	▶ p.30 82 830 0 Ø 63 			
32.5	100	3100	12	▶ p.28 82 850 0 Ø 42 			
33.5		3200	24				
47	170	2630	12	▶ p.30 82 830 5 Ø 63 			
50		2770	24				
90	270	3200	24	▶ p.32 82 890 0 Ø 63 			
95		3360	48				

Selection of a geared motor

A geared motor is selected according to the required usable power output.

$$\text{Usable Power (W)} = \frac{2\pi}{60} C \cdot n \quad (\text{Nm}) \quad (\text{rpm})$$

A geared motor must have usable power equal to or greater than the power required to rotate the load. It is selected by checking that the point corresponding to the required operating conditions (torque and speed output) is higher than the nominal torque versus speed curve of the geared motor. The required torque output of a geared motor must be within its maximum recommended torque for continuous duty.

2			5		6	25
81 033	81 043	81 044	81 035	81 037	81 032 6	81 049
						
 ▶p.40 82 869 0.9 ... 108 rpm	 ▶p.42 82 863 99... 662 rpm	 ▶p.44 82 864 2... 66 rpm		 ▶p.50 82 867 1.72... 344 rpm		
	 ▶p.46 80 813 60... 400 rpm	 ▶p.48 80 814 1... 40 rpm	 ▶p.52 80 815 10.5... 616 rpm	 ▶p.54 80 817 1.04... 208 rpm	 ▶p.60 82 812 5 4 / 8 / 12 rpm	
	 ▶p.46 80 803 60... 400 rpm	 ▶p.48 80 804 1... 40 rpm	 ▶p.52 80 805 10.5... 616 rpm	 ▶p.54 80 807 1.04... 208 rpm	 ▶p.60 82 802 5 4 / 8 / 12 rpm	
						 ▶p.64 80 809 2 11... 477 rpm
			 ▶p.56 80 835 7.4... 426 rpm		 ▶p.62 82 832 5 5 / 8 / 14 rpm	
			 ▶p.58 80 855 13.8... 805 rpm			 ▶p.64 80 859 3 11... 477 rpm
						 ▶p.66 80 839 4 11... 474 rpm
						 ▶p.66 80 899 5 11... 474 rpm

Some principles of direct current (D.C.) motors

Why choose a D.C. motor ?

Many applications call for a high start-up torque. The D.C. motor, by its very nature, has a high torque vs. falling speed characteristic and this enables it to deal with high starting torques and to absorb sudden rises in load easily. The speed of the motor adjusts to the load. Furthermore, the D.C. motor is an ideal way of achieving the miniaturisation designers are constantly seeking because the efficiency it gives is high compared with other designs.

Design of Crouzet D.C. motors

→ Safety

Crouzet D.C. motors are designed and manufactured for integration into equipment or machines which meet, for example, the requirements of the machinery standard :

EN 60335-1 (IEC 335-1, "Safety of domestic electrical appliances").
Integration of Crouzet D.C. motors into equipment or machines should, as a rule, take the following motor characteristics into account :

- no ground connection
- so-called «principal insulation» motors (single insulation)

- protection index : IP00 to IP40
 - insulation classes : A to F
- } (see the catalogue page details for individual motor types)

EC LOW VOLTAGE DIRECTIVE 73/23/EEC OF 19/02/73 :

Crouzet D.C. motors and geared motors are not covered by this directive (LVD 73/23/EEC applies to voltages greater than 75 VDC).

→ Electromagnetic compatibility (EMC)

Crouzet Ltd can provide the EMC characteristics of the various types of product on request.

EC DIRECTIVE 89/336/EEC OF 03/05/89, "ELECTROMAGNETIC COMPATIBILITY" :

D.C. motors and geared motors are considered as components meant for integration into other equipment and therefore fall outside its field of application. However, these products are designed in compliance with EMC characteristics and consequently can be incorporated in equipment having to comply with the EMC directive.

How to select from the Crouzet range

The motor unit is selected according to the required output power. Depending on the required speed, a direct motor or a geared motor is selected.

- Speeds 1,000 to 5,000 rpm → Direct motor
- Speeds below 500 rpm → Geared motor

The gearbox is selected depending on the maximum required torque and the duty cycle.

Definition of the D.C. motor

This motor follows linear laws of operation and because of this it is easier to fully exploit its characteristics compared to synchronous or asynchronous motors.

→ Composition of a D.C. motor

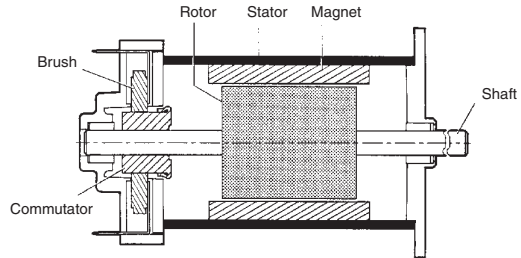

The stator is formed by a metal carcass and one or more magnets that create a permanent magnetic field inside the stator. At the rear of the stator are the brush mountings and the brush gear which provide electrical contact with the rotor.

The rotor is itself formed by a metal carcass carrying coils which are interconnected at the commutator at the rear of the rotor.

The commutator and brush assembly then select the coil through which the electric current passes in the opposite direction.

Principle of operation

Whatever the complexity of the rotor coil windings, once they are energised, they may be represented in the form of a ferromagnetic cylinder with a solenoid wrapped around it.

The wire of the solenoid is in practice the wire bundle located in each groove of the rotor. The rotor, when energised, then acts as an electromagnet, the magnetic field following the axis separating the wires of the solenoid in the direction of the current which flows through them.

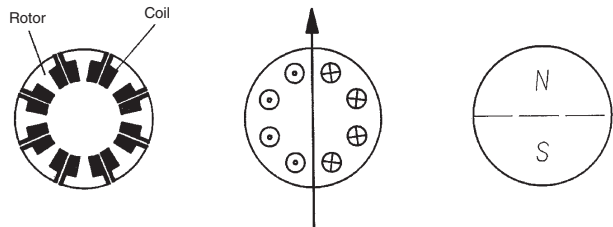

The motor, therefore, consists of fixed permanent magnets (the stator) a moving magnet (the rotor) and a metal carcass to concentrate the flux (the motor body).

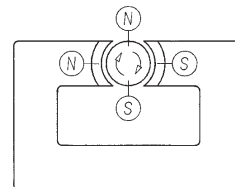

By the attraction of opposite poles and repulsion of like poles, a torque then acts on the rotor and makes it turn. This torque is at a maximum when the axis of the poles of the rotor is perpendicular to the axis of the poles of the stator.

As soon the rotor begins to turn, the fixed brushes make and break contact with the rotating commutator segments in turn.

The rotor coils are then energised and de-energised in such a way that as the rotor turns, the axis of a new pole of the rotor is always perpendicular to that of the stator. Because of the way the commutator is arranged, the rotor is in constant motion, no matter what its position. Fluctuation of the resultant torque is reduced by increasing the number of commutator segments, thereby giving smoother rotation.

By reversing the power supply to the motor, the current in the rotor coils, and therefore the north and south poles, is reversed. The torque which acts on the rotor is thus reversed and the motor changes its direction of rotation. By its very nature, the D.C. motor is a motor with a reversible direction of rotation.

→ Torque and speed of rotation

The torque generated by the motor, and its speed of rotation, are dependent on each other.

This is a basic characteristic of the motor ; it is a linear relationship and is used to calculate the no-load speed and the start-up torque of the motor.

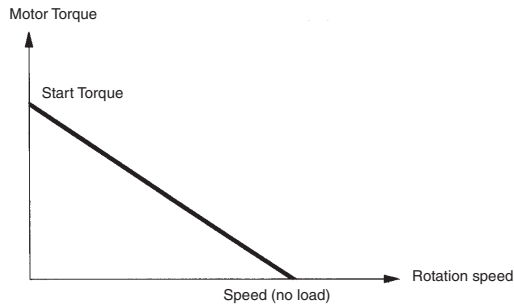

The curve for the output power of the motor is deduced from the graph of torque versus speed.

$$P_u (W) = \frac{2\pi}{60} \times C (N.m) \times N (rpm)$$

Output power	Motor torque	Speed of rotation
--------------	--------------	-------------------

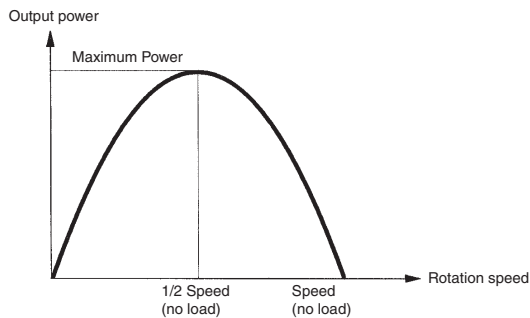

The torque vs. speed and output power curves depend on the supply voltage to the motor.

The supply voltage to the motor assumes continuous running of the motor at an ambient temperature of 20°C in nominal operational conditions.

It is possible to supply the motor with a different voltage (normally between -50% and + 100% of the recommended supply voltage).

If a lower voltage is used compared to the recommended supply the motor will be less powerful.

If a higher voltage is used, the motor will have a higher output power but will run hotter (intermittent operation is recommended).

For variations in supply voltage between approximately - 25% to + 50%, the new torque vs. speed graph will remain parallel to the previous one. Its start-up torque and no-load speed will vary by the same percentage (n%) as the variation in supply voltage. The maximum output power is multiplied by $(1 + n\%)^2$.

Example : For a 20% increase in supply voltage

- Start-up torque increases by 20% (x 1.2)
- No-load speed increases by 20% (x 1.2)
- Output power increases by 44% (x 1.44)

→ Torque and supply current

This is the second important characteristic of a D.C. motor.

It is linear and is used to calculate the no-load current and the current with the rotor stationary (start-up current).

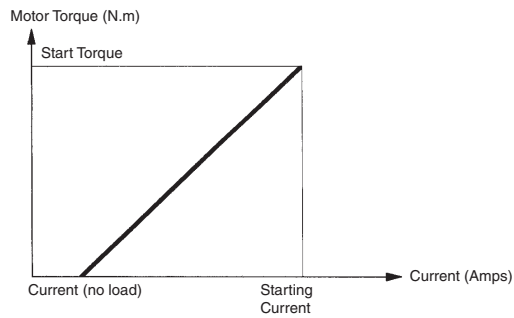

The graph for this relationship does not vary with the supply voltage of the motor. The end of the curve is extended in accordance with the torque and the start-up current.

The gradient of this curve is called the «torque constant» of the motor.

$$K_c = \frac{C_d}{I_d - I_0}$$

This torque constant is such that :

$$C = K_c (I - I_0)$$

The «rotational friction torque» is $K_c I_0$.

The torque is therefore expressed as follows :

$$C = K_c I - C_f \text{ with } C_f = K_c I_0$$

K_c = Torque constant (Nm/A)

C = Torque (Nm)

C_d = Start-up Torque (Nm)

C_f = Rotational friction torque (Nm)

I = Current (A)

I₀ = No-load current (A)

I_d = Start-up current (A)

The graph of torque vs. current and torque vs. speed is used to determine the absorbed power as a function of the speed of rotation of the motor.

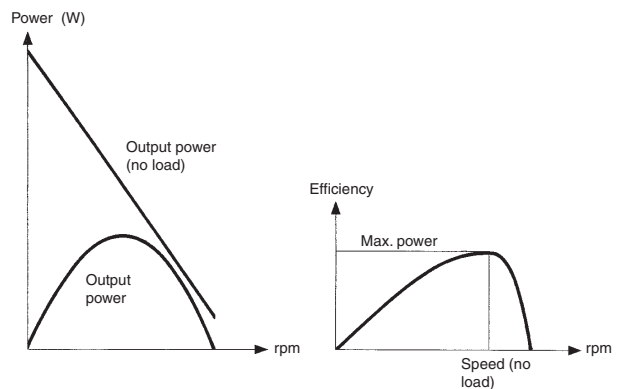

→ Efficiency

The efficiency of a motor is equal to the mechanical output power that it can deliver, divided by the power which it absorbs.

The output power and the absorbed power vary in relation to the speed of rotation, therefore the efficiency is also a function of the speed of the motor.

Maximum efficiency is obtained with a given rotational speed greater than 50% of no-load speed.



→ Temperature rise

The temperature rise of a motor is due to the difference between the absorbed power and the output power of the motor. This difference is the power loss.

Temperature rise is also related to the fact that power loss, in the form of heat from the motor, is not rapidly absorbed by the ambient air (thermal resistance). The thermal resistance of the motor can be greatly reduced by ventilation.

Important

The nominal operating characteristics correspond to the voltage-torque-speed characteristics required for continuous operation at an ambient temperature of 20° C. Only intermittent duty is possible outside these operating conditions : without exception, all checks concerning extreme operating conditions must be performed in the actual customer application conditions in order to ensure safe operation.

Motor and gearbox combinations

D.C. motors are constructed to operate continuously within a range of speeds near their no-load speed. This range of speeds is generally too high for most applications. In order to reduce this speed, a full range of geared motors is available, each with a series of gear ratios to suit most speed requirements.

The complete range is suitable for a wide variety of applications.

→ Gearbox characteristics

Our gearboxes have been designed for optimum performance and for maximum life under normal operating conditions.

Their main characteristic is the capacity to withstand **maximum design torque with continuous duty**.

The range of gearboxes shown in this catalogue can operate with maximum torque of **0.5 to 6 N.m** for long time periods. All values previously stated are for standard products in normal operating conditions, as specified.

In certain cases, these values may be increased if a shorter life is required.

Please consult our Sales Office for further information.

Every gearbox has a torque limit, which is

the breaking torque

If this torque is applied to the gearbox, it will cause severe damage.

→ Gearbox construction

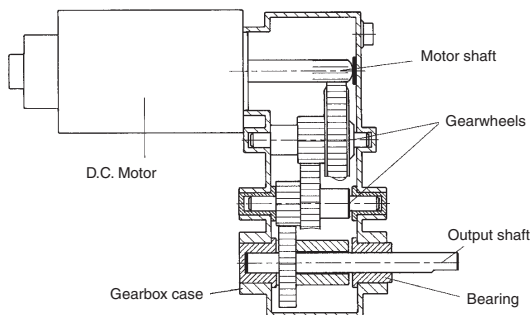

→ Selection of a geared motor

A geared motor is selected according to the required usable power output.

$$P_{\text{useable}} = \frac{2 \pi}{60} \cdot M \cdot n$$

W Nm rpm

A geared motor must have usable power equal to or greater than the power required to rotate the load. It is selected by checking that the point corresponding to the required operating conditions (torque and speed output) is higher than the nominal torque versus speed curve of the geared motor.

The required torque output of a geared motor must be within its maximum recommended torque for continuous duty.

→ Selecting the reduction gear ratio

Two selection criteria may be applied.

- The first criterion concerns the required speed output of the reduction gear only. It is adequate for most applications and is easy to apply. Given that :

$$R = \frac{N_1}{N_b} \quad \begin{array}{l} N_1 = \text{required speed of geared motor} \\ N_b = \text{basic nominal speed of motor} \end{array}$$

- The second criterion concerns the required usable power output of the motor. The rotational speed of the motor is given by :

$$N = 1/2 \left(N_0 + \sqrt{N_0^2 - \frac{4P}{A}} \right) \text{ with } A = \frac{\pi C_d}{30 N_0}$$

- N** = speed of motor (rpm)
- N₀** = no-load speed of motor (rpm)
- P** = required output power (W)
- C_d** = start-up torque of motor (Nm)

This gives the equation : $R = \frac{N_1}{N}$

In order to avoid using numbers less than 1 where the reduction ratio is concerned, the value 1/R is employed.

Due to the fact that it is always a reduction gear and not a «multiplier» gear, there should be no ambiguity concerning the number used.

$$1/R = \frac{N_b}{N_1} \quad \text{or} \quad 1/R = \frac{N}{N_1}$$

D.C. direct drive brushed motors

→ Ø 32 mm 3.9 Watts

- A range of small D.C. direct-drive brushed motors with a case diameter of 32 mm and 3.9 Watts output power. Available in either 12 or 24 V D.C. versions.
- Sintered bronze bearings lubricated for life.
- Connection by 2.8 mm push-on terminals.
- Interference suppression fitted as standard.



Specifications

	3.9 Watts	3.9 Watts with encoder 1 pulse/revolution	3.9 Watts	3.9 Watts with encoder 1 pulse/revolution
Type	82 860 0	82 860 0	82 860 0	82 860 0
Voltage	12 V	12 V	24 V	24 V
Part numbers	82 860 003	82 860 501	82 860 004	82 860 502
No-load characteristics				
Speed of rotation (rpm)	5000	5000	5000	5000
Absorbed power (W)	1.2	1.2	1.92	1.92
Absorbed current (A)	0.1	0.1	0.08	0.08
Nominal characteristics				
Speed (rpm)	3700	3700	3700	3700
Torque (mN.m)	7.7	7.7	7.7	7.7
Usable power (W)	3	3	3	3
Absorbed power (W)	6.2	6.2	6	6
Absorbed current (A)	0.43	0.43	0.26	0.26
Gearbox case temperature rise (°C)	50	50	50	50
Efficiency (%)	48	48	50	50
General characteristics				
Insulation class (conforming to IEC 85)	B (130 °C)	B (130 °C)	B (130 °C)	B (130 °C)
Protection rating	IP40	IP40	IP40	IP40
Max. output (W)	3.9	3.9	3.9	3.9
Start torque (mN.m)	30	30	30	30
Starting current (A)	1.5	1.5	0.76	0.76
Resistance (Ω)	8	8	32	32
Inductance (mH)	10	10	41.6	41.6
Torque constant (Nm/A)	0.0214	0.0214	0.0448	0.0448
Electrical time constant (ms)	1.3	1.3	1.3	1.3
Mechanical time constant (ms)	36	36	36	36
Thermal time constant (min)	8	8	8	8
Inertia (g.cm ²)	19	19	19	19
Weight (g)	96	96	95	95
No of segments	3	3	3	3
Service life (h)	3000	3000	3000	3000
Sintered bronze bearings	✓	✓	✓	✓

Product adaptations

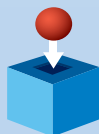

- Special output shafts
- Pinion or bush on output shaft
- Special supply voltages
- Special cable lengths
- Special output bearings
- Optional encoder
- Special mounting plate
- Customised electronics
- Special connectors

To order, see page 13

Curves

A - Nominal speed and torque curves
 B - Torque/Current curves

82 860 0

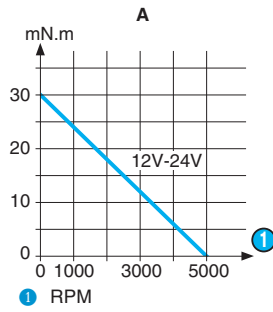

82 860 0

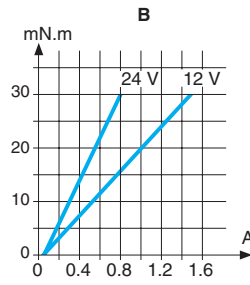

Dimensions

82 860 0

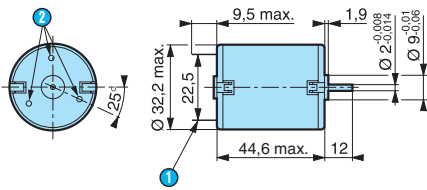

- 1 2 tags NFC 20 - 120 series 2.8 x 0.5 mm
- 2 3 holes at 120° on $\varnothing 26$ mm : use self tapping screws M2.2 ; screw depth max 6 mm

D.C. direct drive brushed motors

→ Ø 42 mm 10 to 17 Watts

- A range of D.C. direct-drive brushed motors with a case diameter of 42 mm and 10 to 17 W output power. Available in either 12, 24 or 48V D.C. versions
- Sintered bronze bearings lubricated for life
- Supply connection by 4.75 mm tags
- Replaceable brushes
- Optional magnetic encoder



Specifications

	10 Watts	10 Watts	17 Watts	17 Watts
Type	82 810 0	82 810 0	82 800 0	82 800 0
Voltage	12 V	24 V	12 V	24 V
Part numbers	82 810 017	82 810 018	82 800 036	82 800 037
No-load characteristics				
Speed of rotation (rpm)	2850	2780	2960	2750
Absorbed power (W)	4.8	4.3	4.8	4.3
Absorbed current (A)	0.4	0.18	0.4	0.18
Nominal characteristics				
Speed (rpm)	2000	2000	2000	2000
Torque (mN.m)	45	41.5	75	75
Usable power (W)	9.4	8.7	15.7	15.6
Absorbed power (W)	20.4	15.6	30	26.4
Absorbed current (A)	1.7	0.65	2.5	1.1
Gearbox case temperature rise (°C)	45	46	44	40
Efficiency (%)	46	55.7	52	59
General characteristics				
Insulation class (conforming to IEC 85)	F (155 °C)	F (155 °C)	F (155 °C)	F (155 °C)
Protection (IEC 529) Housing	IP20	IP20	IP20	IP20
Max. output (W)	10.3	9.5	16.3	17
Start torque (mN.m)	127	117	185	210
Starting current (A)	4	1.7	5.8	2.7
Resistance (Ω)	3.1	14.6	2	7.7
Inductance (mH)	2.5	10.7	1.8	6.9
Torque constant (Nm/A)	0.035	0.077	0.0342	0.0724
Electrical time constant (ms)	0.8	0.73	0.89	0.89
Mechanical time constant (ms)	19	17	18	16
Thermal time constant (min)	10	10	12	12
Inertia (g.cm ²)	80	72	105	110
Weight (g)	310	310	400	400
No of segments	8	8	8	8
Service life (h)	3000	3000	3000	3000
Sintered bronze bearings	✓	✓	✓	✓
Replaceable brushes (mm)	✓	✓	✓	✓

Product adaptations

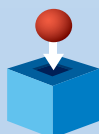

- Special output shafts
- Pinion or bush on output shaft
- Special supply voltages
- Special cable lengths
- Special output bearings
- Optional encoder
- Special mounting plate
- Customised electronics
- Special connectors

To order, see page 13

Curves

A - Torque/Speed curves
B - Torque/Current curves

82 810 0

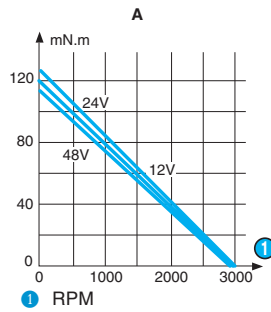

82 810 0

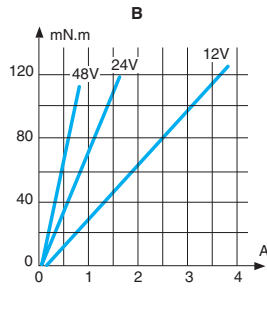

82 800 0

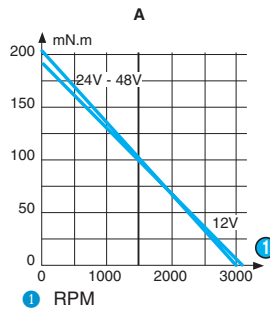

82 800 0

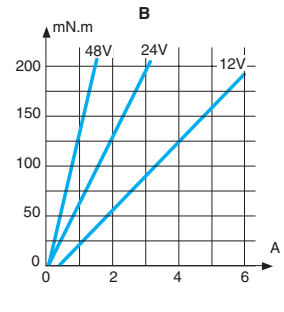

Dimensions

82 810 0

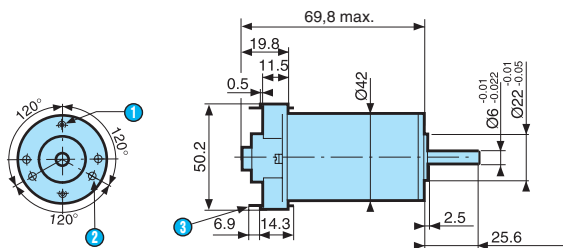

- ① 2 M3 at 180° depth 5 mm on Ø 32
- ② 2 holes x Ø 2.75 ± 0.05 at 120° C depth 5 mm Ø 32
- ③ 2 tags IEC 760 series 4.8 x 0.5 mm

82 800 0

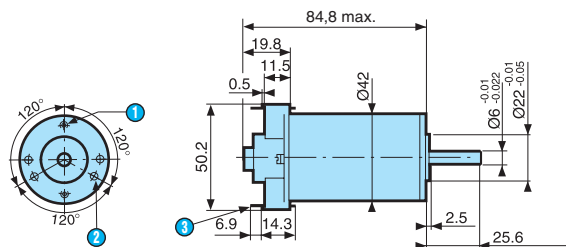

- ① 2 M3 at 180° depth 5 mm on Ø 32
- ② 2 x Ø 2.75 ± 0.05 at 120° depth 5 mm Ø 32
- ③ 2 tags IEC 760 series 4.8 x 0.5 mm

D.C. direct drive brushed motors

→ Ø 42 mm 14 to 31 Watts

- A range of small D.C. direct-drive brushed motors with a case diameter of 42 mm and between 14 and 31 W output power. Available in either 12 or 24 V D.C. versions.
- Sintered bronze bearings lubricated for life
- Replaceable brushes
- Magnetic encoder option



Specifications

	14 Watts	16 Watts	22 Watts	31 Watts
Type	82 810 5	82 810 5	82 800 5	82 800 5
Voltage	12 V	24 V	12 V	24 V
Part numbers	82 810 501	82 810 502	82 800 501	82 800 502
No-load characteristics				
Speed of rotation (rpm)	3840	3860	3920	4010
Absorbed power (W)	12	11.28	9.96	12.24
Absorbed current (A)	1	0.47	0.83	0.51
Nominal characteristics				
Speed (rpm)	2580	2750	2670	3070
Torque (mN.m)	45	45	70	70
Usable power (W)	12	13	20	22
Absorbed power (W)	31	32	37	41
Absorbed current (A)	2.6	1.32	3.05	1.71
Gearbox case temperature rise (°C)	32	33	38	40
Efficiency (%)	39	40.8	54	54
General characteristics				
Insulation class (conforming to IEC 85)	F (155 °C)	F (155 °C)	F (155 °C)	F (155 °C)
Protection (IEC 529) Housing	IP20	IP20	IP20	IP20
Max. output (W)	14	16	22	31
Start torque (mN.m)	138	156	219	298
Starting current (A)	6.2	3.4	9	6.16
Resistance (Ω)	1.94	7.06	1.33	3.9
Inductance (mH)	4.45	16.94	2.67	9.35
Torque constant (Nm/A)	0.0265	0.0532	0.0268	0.0527
Electrical time constant (ms)	2.3	2.4	2	2.4
Mechanical time constant (ms)	26	23	20	15
Thermal time constant (min)	8	8	12	12
Inertia (g.cm ²)	80	72	105	110
Weight (g)	310	310	400	400
No of segments	8	8	8	8
Service life (h)	2000	2000	2000	2000
Sintered bronze bearings	✓	✓	✓	✓
Replaceable brushes (mm)	✓	✓	✓	✓

Product adaptations

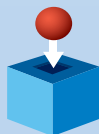

- Special output shafts
- Pinion or bush on output shaft
- Special supply voltages
- Special cable lengths
- Special output bearings
- Optional encoder
- Special mounting plate
- Customised electronics
- Special connectors

To order, see page 13

Curves

A - Torque/Speed curves
B - Torque/Current curves

82 810 5

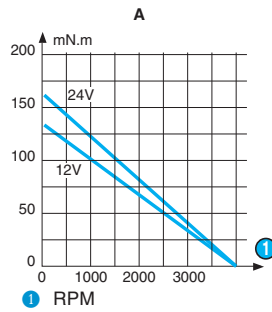

82 810 5

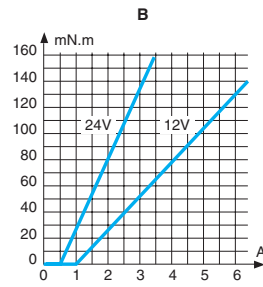

82 800 5

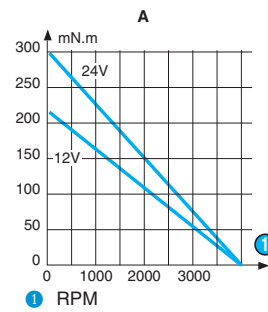

82 800 5

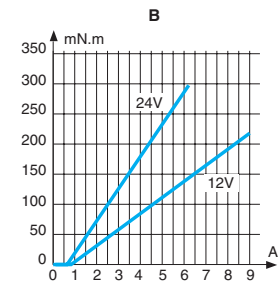

Dimensions

82 810 5

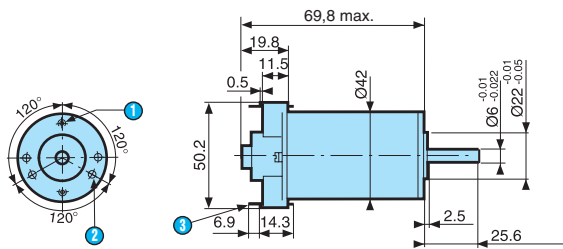

- ① 2 M3 at 180° depth 5 mm on Ø 32
- ② 2 x Ø 2.75 at 120° depth 5 mm on Ø 32
- ③ 2 tags IEC 760 series 4.8 x 0.5 mm

82 800 5

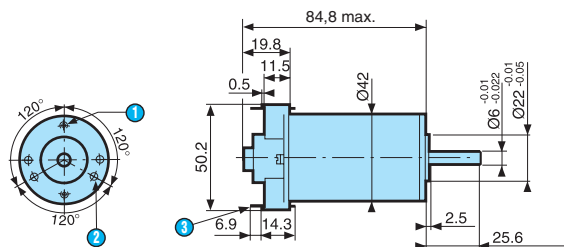

- ① 2 M3 at 180° depth 5 mm on Ø 32
- ② 2 x Ø 2.75 at 120° depth 5 mm on Ø 32
- ③ 2 tags IEC 760 series 4.8 x 0.5 mm

D.C. direct drive brushed motors

→ Ø 42 mm 22 to 52 Watts

- A range of small D.C. direct-drive brushed motors with a case diameter of 42 mm and between 22 and 52 Watts output power. Available in either 12 or 24 V D.C. versions.
- Sintered bronze bearings lubricated for life
- Supply connection by 2 leads



Specifications

	22 Watts	31 Watts	42 Watts	52 Watts
Type	82 800 8	82 800 8	82 850 0	82 850 0
Voltage	12 V	24 V	12 V	24 V
Part numbers	82 800 801	82 800 802	82 850 001	82 850 002
No-load characteristics				
Speed of rotation (rpm)	3920	4010	4150	4050
Absorbed power (W)	9.96	12.24	7.32	7.44
Absorbed current (A)	0.83	0.51	0.61	0.31
Nominal characteristics				
Speed (rpm)	2670	3070	3100	3200
Torque (mN.m)	70	70	100	100
Usable power (W)	20	22	32.5	33.5
Absorbed power (W)	37	41	51	52
Absorbed current (A)	3.05	1.71	4.25	2.15
Gearbox case temperature rise (°C)	38	40	63	54
Efficiency (%)	54	54	63	64
General characteristics				
Insulation class (conforming to IEC 85)	F (155 °C)	F (155 °C)	F (155 °C)	F (155 °C)
Protection (IEC 529) Terminal	IP20	IP20	IP20	IP20
Max. output (W)	22	31	42	52
Start torque (mN.m)	219	298	390	490
Starting current (A)	9	6.16	14.8	9.6
Resistance (Ω)	1.33	3.9	0.81	2.5
Inductance (mH)	2.67	9.35	0.7	2.5
Torque constant (Nm/A)	0.0268	0.0527	0.027	0.052
Electrical time constant (ms)	2	2.4	0.85	1
Mechanical time constant (ms)	20	15	16	13
Thermal time constant (min)	12	12	26	21
Inertia (g.cm ²)	105	110	140	140
Weight (g)	400	400	640	640
No of segments	8	8	8	8
Service life (h)	3000	3000	3000	3000
Sintered bronze bearings	✓	✓	✓	✓
Wires length (mm)	200	200	200	200

Product adaptations

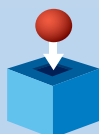

- Special output shafts
- Pinion or bush on output shaft
- Special supply voltages
- Special cable lengths
- Special output bearings
- Optional encoder
- Special mounting plate
- Customised electronics
- Special connectors

To order, see page 13

Curves

A - Torque/Speed curves
B - Torque/Current curves

82 800 8

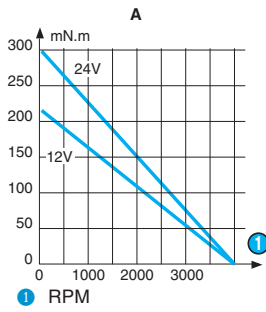

82 800 8

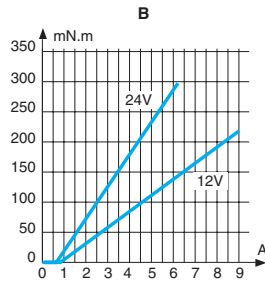

82 850 0

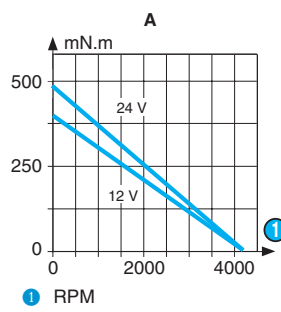

82 850 0

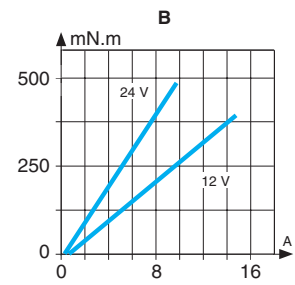

Dimensions

82 800 8

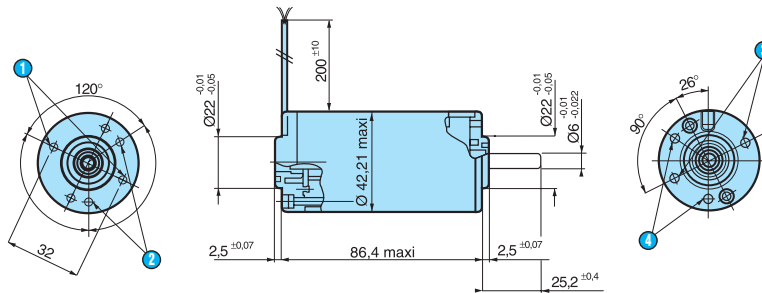

- 1 2 holes M3 x 0.5 at 180° depth 5 on Ø 32
- 2 2 holes 2.75 ±0.05 at 120° depth 5 mm on Ø 32
- 3 2 holes M3 x 0.5 at 180° depth 5.5 on Ø 32
- 4 2 holes M3 x 0.5 at 120° depth 5.5 on Ø 32

82 850 0

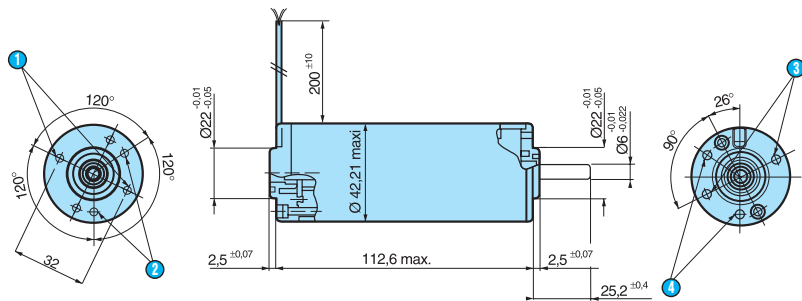

- 1 2 holes M3 x 0.5 at 180° depth 5 mm on Ø 32
- 2 2 holes 2.75 ± 0.05 at 120° depth 5 mm on Ø 32
- 3 2 holes M3 x 0.5 at 180° depth 5.5 mm on Ø 32
- 4 2 holes M3 x 0.5 at 120° depth 5.5 mm on Ø 32

D.C. direct drive brushed motors

→ Ø 63 mm 33 to 67Watts

- A range of D.C. direct-drive brushed motors with a case diameter of 63 mm and 33 to 67 W output power. Available in either 12, 24 or 48V D.C. versions.
- Ball bearings on output shaft
- Supply connection by 2 leads



Specifications

	33 watts	33 Watts	67 Watts	67 Watts
Type	82 830 0	82 830 0	82 830 5	82 830 5
Voltage	12 V	24 V	12 V	24 V
Part numbers	82 830 009	82 830 010	82 830 501	82 830 502
No-load characteristics				
Speed of rotation (rpm)	2100	2100	3400	3660
Absorbed power (W)	4.8	4.8	12.6	12
Absorbed current (A)	0.4	0.2	1.05	0.5
Nominal characteristics				
Speed (rpm)	1500	1500	2630	2770
Torque (mN.m)	172	172	170	170
Usable power (W)	27	27	47	50
Absorbed power (W)	43	45	72	72
Absorbed current (A)	3.6	1.9	6	3
Gearbox case temperature rise (°C)	50	50	46	50
Efficiency (%)	62	60	65	69.4
General characteristics				
Insulation class (conforming to IEC 85)	F (155 °C)	F (155 °C)	F (155 °C)	F (155 °C)
Protection (IEC 529) Terminal	IP20	IP20	IP20	IP20
Max. output (W)	33	33	67	67
Start torque (mN.m)	600	600	750	700
Starting current (A)	12	6.2	23.1	11.8
Resistance (Ω)	1	3.9	0.52	2.03
Inductance (mH)	1.4	6.4	1.19	4.68
Torque constant (Nm/A)	0.0517	0.1	0.034	0.0619
Electrical time constant (ms)	1.4	1.64	2.3	2.3
Mechanical time constant (ms)	19	19	33	33
Thermal time constant (min)	37	37	20	18
Inertia (g.cm ²)	514	492	520	500
Weight (g)	840	840	840	840
No of segments	12	12	12	12
Service life (h)	5000	5000	4000	4000
Ball bearings	✓	✓	✓	✓
Wires length (mm)	200	200	200	200

Product adaptations

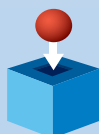

- Special output shafts
- Pinion or bush on output shaft
- Special supply voltages
- Special cable lengths
- Special output bearings
- Optional encoder
- Special mounting plate
- Customised electronics
- Special connectors

To order, see page 13

Curves

A - Torque/Speed curves
B - Torque/Current curves

82 830 0

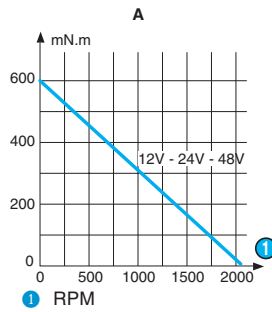

82 830 0

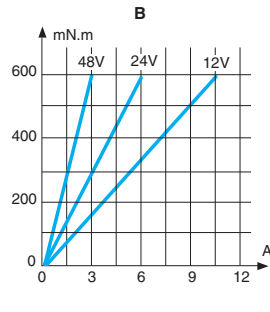

82 830 5

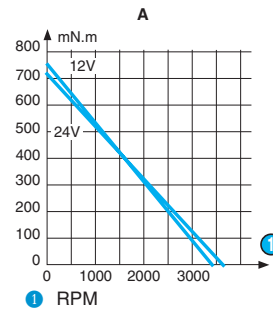

82 830 5

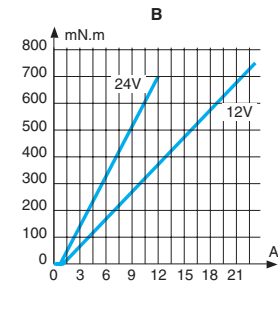

Dimensions

82 830 0

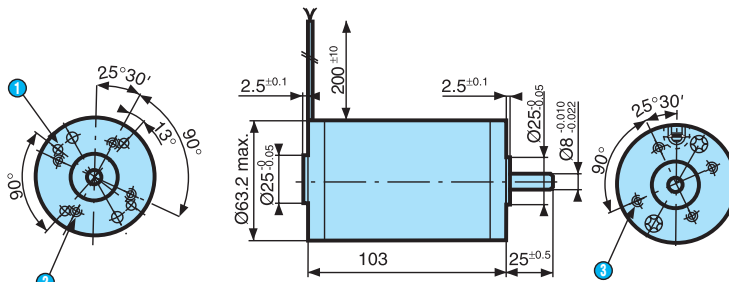

- 1 4 holes $\text{Ø} 3.65^{+0.05}$ at 90° on $\text{Ø} 48$
- 2 4 holes M5 on $\text{Ø} 40$ depth 7 mm
- 3 4 holes M5 on $\text{Ø} 40$ depth 7 mm

D.C. direct drive brushed motors

→ Ø 63 mm 194 to 255 Watts

- A range of D.C. direct-drive brushed motors with a case diameter of 63 mm and between 194 and 255 Watts output power. Available in either 24 or 48V D.C. versions
- Ball bearings on output shaft
- Supply connection by 2 leads



Specifications

	194 Watts	255 Watts
Type	82 890 0	82 890 0
Voltage	24 V	48 V
Part numbers	82 890 001	82 890 002
No-load characteristics		
Speed of rotation (rpm)	3700	3750
Absorbed power (W)	10.8	9.6
Absorbed current (A)	0.45	0.2
Nominal characteristics		
Speed (rpm)	3200	3360
Torque (mN.m)	270	270
Usable power (W)	90	95
Absorbed power (W)	120	118
Absorbed current (A)	5.00	2.45
Gearbox case temperature rise (°C)	50	50
Efficiency (%)	75	80
General characteristics		
Insulation class (conforming to IEC 85)	F (155 °C)	F (155 °C)
Protection (IEC 529) Terminal	IP20	IP20
Max. output (W)	194	255
Start torque (mN.m)	2000	2600
Starting current (A)	34.1	21.7
Resistance (Ω)	0.7	2.2
Inductance (mH)	1.05	4.62
Torque constant (Nm/A)	0.059	0.12
Electrical time constant (ms)	1.5	2.1
Mechanical time constant (ms)	16	12
Thermal time constant (min)	41	36
Inertia (g.cm ²)	795	795
Weight (g)	1580	1580
No of segments	12	12
Service life (h)	5000	5000
Ball bearings	✓	✓
Wires length (mm)	200	200

Product adaptations

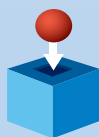

- Special output shafts
- Pinion or bush on output shaft
- Special supply voltages
- Special cable lengths
- Special output bearings
- Optional encoder
- Special mounting plate
- Customised electronics
- Special connectors

To order, see page 13

Curves

A - Torque/Speed curves
 B - Torque/Current curves

82 890 0

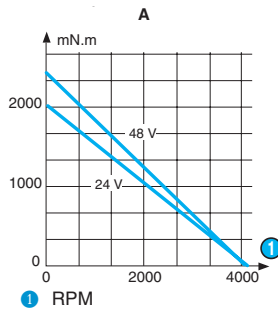

82 890 0

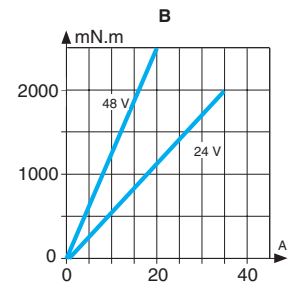

Dimensions

82 890 0

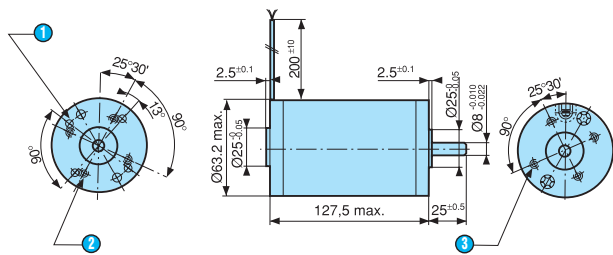

- 1 4 holes $\varnothing 3.65^{+0.05}$ at 90° on $\varnothing 48$
- 2 4 holes M5 on $\varnothing 40$ depth 7 mm
- 3 4 holes M5 on $\varnothing 40$ depth 7 mm

D.C. geared motors with brushes

→ 0.5 Nm 3.9 Watts

- A range of D.C. geared motors with sintered metal gears. Mechanical rating of gearbox with output shaft stalled : 0.5 Nm.
- 3.9 Watt motor power
- Available in either 12 or 24 V D.C. versions.
- Gearbox ratios options for 1.5 to 441 rpm.
- Options with magnetic encoder.



Specifications

		3.9 Watts	3.9 Watts
Type		82 862 0/2	82 862 0/2
Voltage		12 V	24 V
Output speed (rpm)	Ratios (i)		
441	9.76	82 862 001	82 862 004
141	30.6	82 862 002	82 862 005
45	95.4	82 862 003	82 862 006
14	298	82 862 201	82 862 204
5	931	82 862 202	82 862 205
1.5	2910	82 862 203	82 862 206
General characteristics			
Motor		82 860 0	82 860 0
Gearbox		81 012 0 / 81 012 2	81 012 0 / 81 012 2
Maximum permitted torque from gearmotor under continuous conditions (for 1 millions turns) N.m		0.5	0.5
Axial load static (daN)		1	1
Radial load static (daN)		8	8
Max. output (W)		3.9	3.9
Nominal output (W)		3	3
Gearbox case temperature rise (°C)		50	50
Weight (g)		160 / 170	160 / 170

Product adaptations

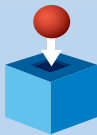

- Special supply voltages
- Special cable lengths
- Optional encoder
- Special connectors
- Special output shafts
- Special gearbox ratios
- Special gear wheel material
- Special output bearings
- Special mounting plate

To order, see page 13

Curves

The shaded zone represents the operating range of the geared motor.
The horizontal line marks the maximum torque available in continuous duty cycle for a given life.
For higher torque ratings, service life will be reduced.

Nominal speed and torque curves

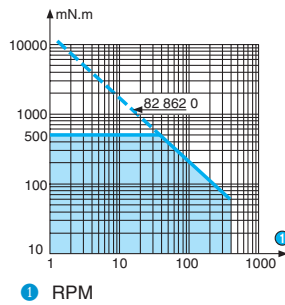

Dimensions

82 862 0

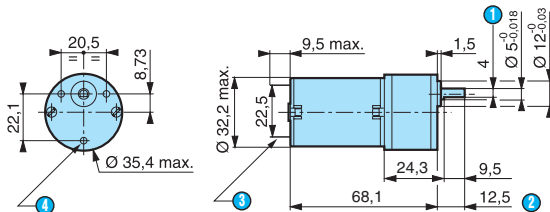

- 1 4 mm across flats
- 2 (shaft pushed-in ←)
- 3 2 tags NFC 20-120 series 2.8 x 0.5 mm
- 4 3 holes M3 depth 4.5 mm

82 862 2

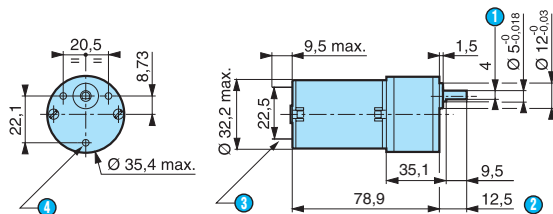

- 1 4 mm across flats
- 2 (shaft pushed-in ←)
- 3 2 tags NFC 20-120 series 2.8 x 0.5 mm
- 4 3 holes M3 depth 4.5 mm

D.C. geared motors with brushes

→ 0.5 Nm 3.9 Watts

- A range of D.C. geared motors with ovoid gearbox.
Mechanical rating of gearbox with output shaft stalled : 0.5 Nm.
- 3.9 Watt motor versions.
- Available in either 12 or 24 V D.C.
- Gearbox ratios options for 0.36 to 430 rpm.



Specifications

		3.9 Watts	3.9 Watts
Type		82 861 0	82 861 0
Voltage		12 V	24 V
Standard speed (rpm)		4300	4300
Output speed (rpm)	Ratios (i)		
430	10	82 861 006	82 861 015
215	20	82 861 007	82 861 016
179	24	●	●
143	30	82 861 008	82 861 017
108	40	82 861 009	82 861 018
90	48	●	●
54	80	82 861 010	82 861 019
49	90	●	●
29	150	●	●
22	200	82 861 011	82 861 020
11	375	82 861 012	82 861 021
8.6	500	82 861 013	82 861 022
5.8	750	●	●
3.6	1200	82 861 014	82 861 023
1.8	2400	●	●
0.80	5400	●	●
0.36	12000	●	●
General characteristics			
Motor		82 860 0	82 860 0
Gearbox		81 021 0	81 021 0
Maximum permitted torque from gearmotor under continuous conditions (for 1 millions turns) Nm		0.5	0.5
Axial load static (daN)		1	1
Radial load static (daN)		8	8
Max. output (W)		3.9	3.9
Nominal output (W)		3	3
Gearbox case temperature rise (°C)		50	50
Weight (g)		160	160

Product adaptations

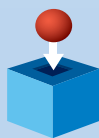

- Special supply voltages
- Special cable lengths
- Optional encoder
- Special connectors
- Special output shafts
- Special gearbox ratios
- Special gear wheel material
- Special output bearings
- Special mounting plate

To order, see page 13

Curves

The shaded zone represents the operating range of the geared motor.
The horizontal line marks the maximum torque available in continuous duty cycle for a given life.
For higher torque ratings, service life will be reduced.

Nominal speed and torque curves

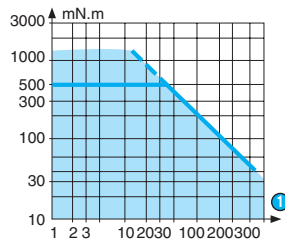

1 RPM

Dimensions

82 861 0

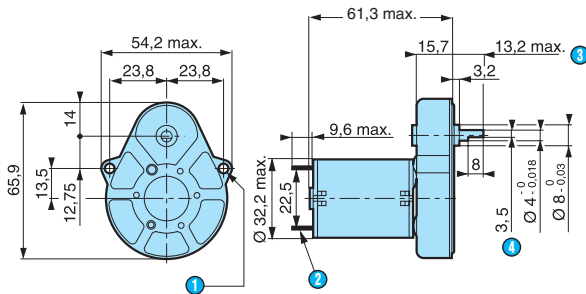

- 1 2 fixing holes $\text{Ø} 3.2$
- 2 2 tags NFC 20-120 series 2.8×0.5 mm
- 3 (shaft pushed-in \leftarrow)
- 4 3.5 mm across flats

Options

Shaft 70 999 421
SP1295.10

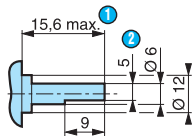

- 1 (shaft pushed-in \leftarrow)
- 2 5 across flat

Shaft 79 200 779

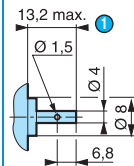

- 1 (shaft pushed-in \leftarrow)

Shaft 79 200 967

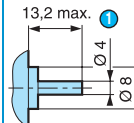

- 1 (shaft pushed-in \leftarrow)

D.C. geared motors with brushes

→ 1.2 Nm 10 and 17 Watts

- A range of D.C. geared motors with solid metal gears
- Mechanical rating of gearbox with output shaft stalled : 1.2 Nm
- 10 and 17 Watt motor power
- Available in either 12, 24 or 48 V D.C.
- Gearbox ratios options for 20 to 100 rpm



Specifications

		17 Watts	17 Watts	10 Watts	10 watts
Type		82 802 0	82 802 0	82 812 0	82 812 0
Voltage		12 V	24 V	12 V	24 V
Output speed (rpm)	Ratios (i)				
100	26	●	●	●	●
80	32.5	●	●	●	●
60	130/3	●	●	●	●
38	67.6	●	●	●	●
30	598/7	●	●	●	●
20	130	●	●	●	●
General characteristics					
Motor		82 800 0	82 800 0	82 810 0	82 810 0
Gearbox		81 032 1	81 032 1	81 032 1	81 032 1
Maximum permitted torque from gearmotor under continuous conditions for 10 millions turns (Nm)		1.2	1.2	1.2	1.2
Axial load dynamic (daN)		3.5	3.5	3.5	3.5
Radial load dynamic (daN)		5	5	5	5
Max. output (W)		16.3	17	10.3	9.5
Nominal output (W)		15.7	15.6	9.4	8.7
Gearbox case temperature rise (°C)		44	40	45	46
Weight (g)		670	670	670	670

Product adaptations

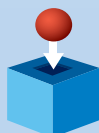

- Special supply voltages
- Special cable lengths
- Optional encoder
- Special connectors
- Special output shafts
- Special gearbox ratios
- Special gear wheel material
- Special output bearings
- Special mounting plate

To order, see page 13

Curves

The shaded zone represents the operating range of the geared motor.
The horizontal line marks the maximum torque available in continuous duty cycle for a given life.
For higher torque ratings, service life will be reduced.

Nominal speed and torque curves
82 802 0

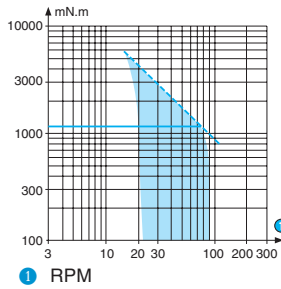

Nominal speed and torque curves
82 812 0

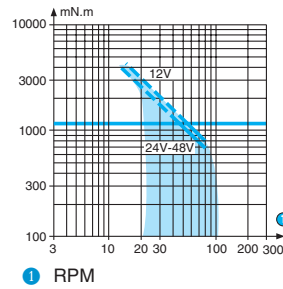

Dimensions

82 802 0

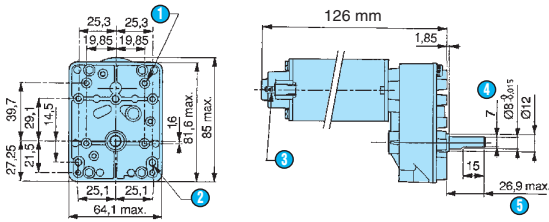

- ① 4 holes M4 depth 7.5 mm
- ② 3 holes M5 at 120° depth 7.5 mm
- ③ 2 tags IEC 760 series 4.8 x 0.5 mm
- ④ 7 mm across flats
- ⑤ (shaft pushed-in ←)

82 812 0

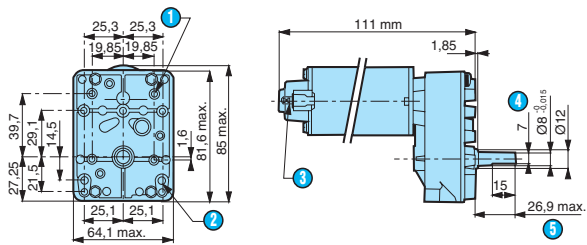

- ① 8 holes M4 depth 7.5 mm
- ② 3 holes M5 at 120° depth 7.5 mm
- ③ 2 tags IEC 760 series 4.8 x 0.5 mm
- ④ 7 mm across flats
- ⑤ (shaft pushed-in ←)

D.C. geared motors with brushes

→ 2 Nm 3.9 Watts

- A range of D.C. geared motors with ovoid gearbox.
Mechanical rating of gearbox with output shaft stalled : 2 Nm.
- 3.9 Watt motor versions.
- Available in either 12 or 24 V D.C.
- Gearbox ratios options for 0.36 to 430 rpm.
- Alternative shaft options.



Specifications

		3.9 Watts	3.9 Watts
Type		82 869 0	82 869 0
Voltage		12 V	24 V
Output speed (rpm)	Ratios (i)		
108	40	82 869 001	82 869 011
54	80	82 869 006	82 869 012
27	160	82 869 007	82 869 013
13	320	82 869 008	82 869 014
7.2	600	82 869 009	82 869 015
5.4	800	●	●
2.9	1500	82 869 010	82 869 016
0.90	4800	●	●
General characteristics			
Motor		82 860 0	82 860 0
Gearbox		81 033 0	81 033 0
Maximum permitted torque from gearmotor under continuous conditions for 1 millions turns (Nm)		2	2
Axial load static (daN)		1	1
Radial load static (daN)		10	10
Max. output (W)		3.9	3.9
Nominal output (W)		3	3
Gearbox case temperature rise (°C)		50	50
Weight (g)		240	240

Product adaptations

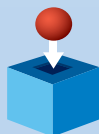

- Special supply voltages
- Special cable lengths
- Optional encoder
- Special connectors
- Special output shafts
- Special gearbox ratios
- Special gear wheel material
- Special output bearings
- Special mounting plate

To order, see page 13

Curves

The shaded zone represents the operating range of the geared motor.
The horizontal line marks the maximum torque available in continuous duty cycle for a given life.
For higher torque ratings, service life will be reduced.

Nominal speed and torque curves

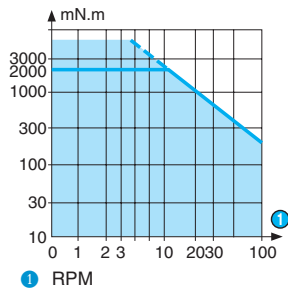

Dimensions

82 869 0

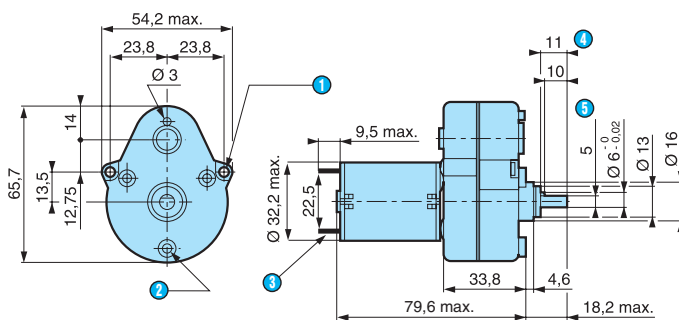

- 1 2 fixing holes $\text{Ø } 3.2$
- 2 3 bosses $\text{Ø } 7.2$ at 120° on $R=19.5$ with 3 M3 holes
- 3 2 tags NFC 20-120 series 2.8×0.5 mm
- 4 (shaft pushed-in \leftarrow)
- 5 5 mm across flats

Options

Shaft 79 202 573

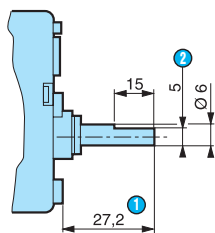

- 1 (shaft pushed-in \leftarrow)
- 2 5 across flat

D.C. geared motors with brushes

→ 2 Nm 3.9 Watts

- A range of D.C. geared motors with metal gearbox.
Mechanical rating of gearbox with output shaft stalled : 2 Nm.
- 3.9 Watt motor power.
- Available in either 12 or 24 V D.C.
- Gearbox ratios options for 99 to 662 rpm.



Specifications

		3.9 Watts	3.9 Watts
Type		82 863 0	82 863 0
Voltage		12 V	24 V
Output speed (rpm)	Ratios (i)		
662	13/2	●	●
498	855/99	●	●
266	728/45	●	●
198	65/3	●	●
170	455/18	●	●
132	32.5	●	●
99	130/3	●	●
General characteristics			
Motor		82 860 0	82 860 0
Gearbox		81 043 0	81 043 0
Maximum permitted torque from gearmotor under continuous conditions (for 1 millions turns) (Nm)		2	2
Axial load dynamic (daN)		2	2
Radial load dynamic (daN)		2	2
Max. output (W)		3.9	3.9
Nominal output (W)		3	3
Gearbox case temperature rise (°C)		50	50
Weight (g)		285	285

Product adaptations

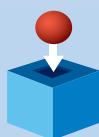

- Special supply voltages
- Special cable lengths
- Optional encoder
- Special connectors
- Special output shafts
- Special gearbox ratios
- Special gear wheel material
- Special output bearings
- Special mounting plate

To order, see page 13

Curves

The shaded zone represents the operating range of the geared motor.
The horizontal line marks the maximum torque available in continuous duty cycle for a given life.
For higher torque ratings, service life will be reduced.

Nominal speed and torque curves

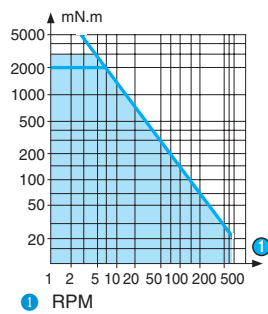

Dimensions

82 863 0

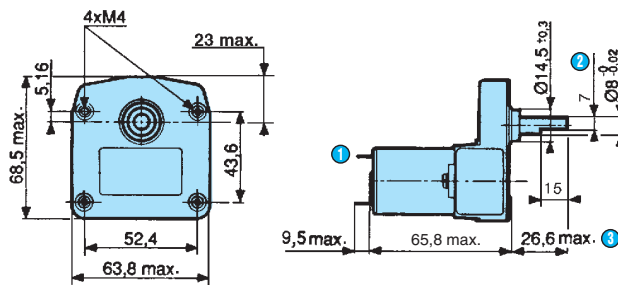

- ① 2 tags NFC 20-120 series 2.8 x 0.5 mm
- ② 7 mm across flats
- ③ (shaft pushed-in ←)

Options

Shaft 79 261 300

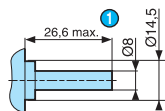

- ① (shaft pushed-in ←)

Shaft 79 261 309

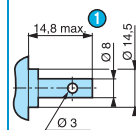

- ① (shaft pushed-in ←)

D.C. geared motors with brushes

→ 2 Nm 3.9 Watts

- A range of D.C. geared motors with metal gearbox.
Mechanical rating of gearbox with output shaft stalled : 2 Nm.
- 3.9 Watt motor versions.
- Available in either 12 or 24 V D.C.
- Gearbox ratios options for 2 to 66 rpm.



Specifications

		3.9 Watts	3.9 Watts
Type		82 864 0	82 864 0
Voltage		12 V	24 V
Output speed (rpm)	Ratios (i)		
66	65	•	•
40	325/3	•	•
26	162.5	•	•
13	325	•	•
7	650	•	•
2	2600	•	•
General characteristics			
Motor		82 860 0	82 860 0
Gearbox		81 044 0	81 044 0
Maximum permitted torque from gearmotor under continuous conditions (for 1 millions turns) (Nm)		2	2
Axial load dynamic (daN)		2	2
Radial load dynamic (daN)		2	2
Max. output (W)		3.9	3.9
Nominal output (W)		3	3
Gearbox case temperature rise (°C)		50	50
Weight (g)		355	355

Product adaptations

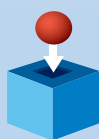

- Special supply voltages
- Special cable lengths
- Optional encoder
- Special connectors
- Special output shafts
- Special gearbox ratios
- Special gear wheel material
- Special output bearings
- Special mounting plate

To order, see page 13

Curves

The shaded zone represents the operating range of the geared motor.
The horizontal line marks the maximum torque available in continuous duty cycle for a given life.
For higher torque ratings, service life will be reduced.

Nominal speed and torque curves

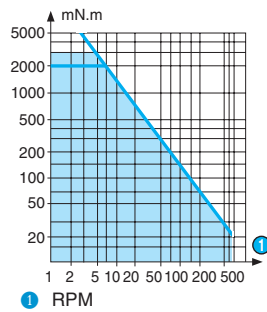

Dimensions

82 864 0

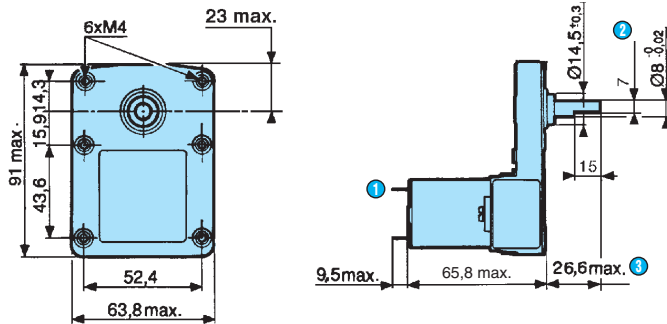

- ① 2 tags NFC 20-120 series 2.8 x 0.5 mm
- ② 7 mm across flats
- ③ (shaft pushed-in ←)

Options

Shaft 79 261 300

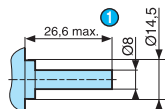

- ① (shaft pushed-in ←)

Shaft 79 261 309

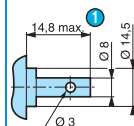

- ① (shaft pushed-in ←)

Shaft 79 261 314

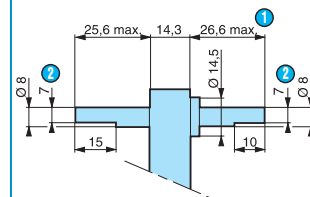

- ① (shaft pushed-in ←)
- ② 7 across flat

D.C. geared motors with brushes

→ 2 Nm 10 and 17 Watts

- A range of D.C. geared motors with solid metal gears
Mechanical rating of gearbox with output shaft stalled : 1.2 Nm
- 10 and 17 Watt motor power
- Available in either 12, 24 or 48 V D.C.
- Gearbox ratios options for 60 to 400 rpm



Specifications

		17 Watts	17 Watts	10 Watts	10 Watts
Type		80 803 0	80 803 0	80 813 0	80 813 0
Voltage		12 V	24 V	12 V	24 V
Output speed (rpm)	Ratios (i)				
400	13/2	●	●	●	●
301	855/99	●	●	●	●
161	728/45	80 803 005	80 803 008	●	●
120	65/3	●	●	●	●
103	455/18	●	●	●	●
80	32.5	80 803 006	80 803 009	●	●
60	130/3	80 803 007	80 803 010	●	●
General characteristics					
Motor		82 800 0	82 800 0	82 810 0	82 810 0
Gearbox		81 043 0	81 043 0	81 043 0	81 043 0
Maximum permitted torque from gearmotor under continuous conditions for 1 millions turns Nm		2	2	2	2
Axial load dynamic (daN)		2	2	2	2
Radial load dynamic (daN)		2	2	2	2
Max. output (W)		16.3	17	10.3	9.5
Nominal output (W)		15.7	15.6	9.4	8.7
Gearbox case temperature rise (°C)		44	40	45	46
Weight (g)		600	600	500	500

Product adaptations

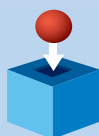

- Special supply voltages
- Special cable lengths
- Optional encoder
- Special connectors
- Special output shafts
- Special gearbox ratios
- Special gear wheel material
- Special output bearings
- Special mounting plate

To order, see page 13

Curves

The shaded zone represents the operating range of the geared motor.
The horizontal line marks the maximum torque available in continuous duty cycle for a given life.
For higher torque ratings, service life will be reduced.

Nominal speed and torque curves 80 803 0

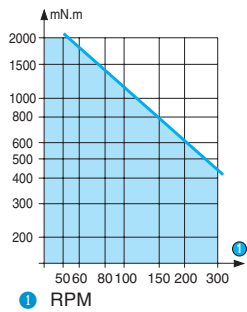

Nominal speed and torque curves 80 813 0

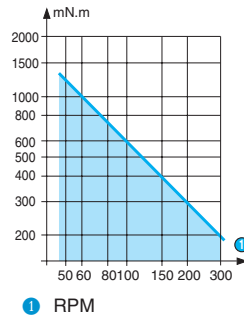

Dimensions

80 803 0

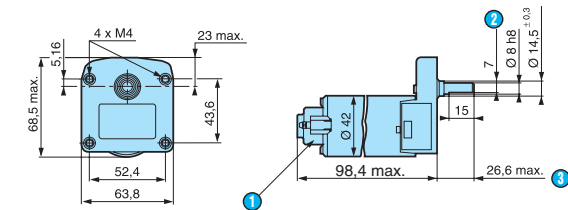

- 1 2 tags IEC 760 series 4.8 x 0.5 mm
- 2 7 mm across flats
- 3 (shaft pushed-in ←)

80 813 0

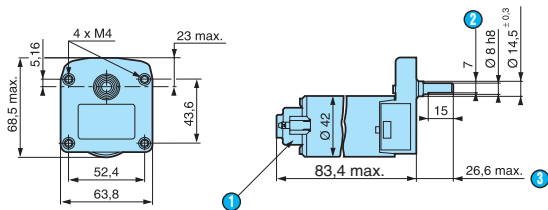

- 1 2 tags IEC 760 series 4.8 x 0.5 mm
- 2 7 mm across flats
- 3 (shaft pushed-in ←)

Options

Shaft 79 261 300

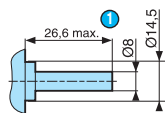

- 1 (shaft pushed-in ←)

Shaft 79 261 309

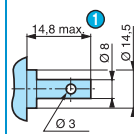

- 1 (shaft pushed-in ←)

D.C. geared motors with brushes

→ 2 Nm 10 and 17 Watts

- A range of D.C. geared motors with solid metal gears. Mechanical rating of gearbox with output shaft stalled : 2 Nm.
- 10 and 17 Watt motor power.
- Available in either 12, 24 or 48 V D.C.
- Gearbox ratios options for 1 to 40 rpm.



Specifications

		17 Watts	17 Watts	10 Watts	10 Watts
Type		80 804 0	80 804 0	80 814 0	80 814 0
Voltage		12 V	24 V	12 V	24 V
Output speed (rpm)	Ratios (i)				
40	65	●	●	●	●
24	325/3	80 804 006	80 804 009	●	●
16	162.5	●	●	●	●
8	325	80 804 007	80 804 010	●	●
4	650	80 804 008	80 804 011	●	●
1	2600	●	●	●	●
General characteristics					
Motor		82 800 0	82 800 0	82 810 0	82 810 0
Gearbox		81 044 0	81 044 0	81 044 0	81 044 0
Maximum permitted torque from gearmotor under continuous conditions for 1 millions turns Nm		2	2	2	2
Axial load dynamic (daN)		2	2	2	2
Radial load dynamic (daN)		2	2	2	2
Max. output (W)		16.3	17	10.3	9.5
Nominal output (W)		15.7	15.6	9.3	8.7
Gearbox case temperature rise (°C)		44	40	45	46
Weight (g)		670	670	570	570

Product adaptations

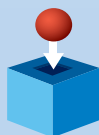

- Special supply voltages
- Special cable lengths
- Optional encoder
- Special connectors
- Special output shafts
- Special gearbox ratios
- Special gear wheel material
- Special output bearings
- Special mounting plate

To order, see page 13

Curves

The shaded zone represents the operating range of the geared motor.
The horizontal line marks the maximum torque available in continuous duty cycle for a given life.
For higher torque ratings, service life will be reduced.

Nominal speed and torque curves 80 804 0

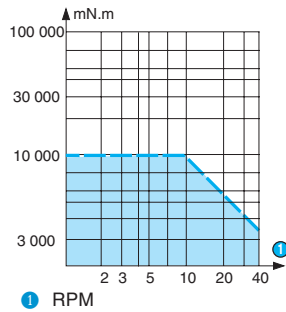

Nominal speed and torque curves 80 814 0

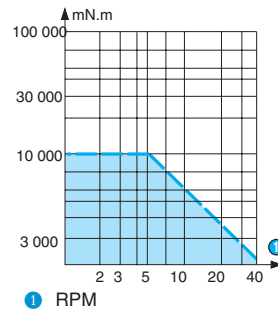

Dimensions

80 804 0

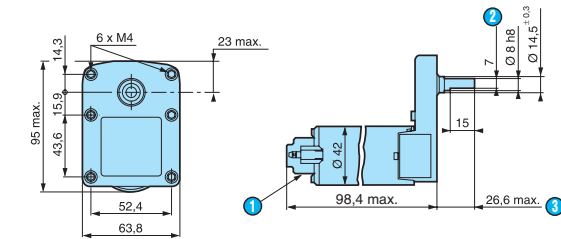

- ① 2 tags IEC 760 series 4.8 x 0.5 mm
- ② 7 mm across flats
- ③ (shaft pushed-in ←)

80 814 0

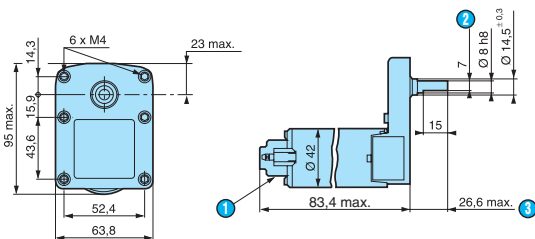

- ① 2 tags IEC 760 series 4.8 x 0.5 mm
- ② 7 mm across flats
- ③ (shaft pushed-in)

Options

Shaft 79 261 300

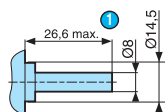

- ① (shaft pushed-in ←)

Shaft 79 261 309

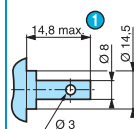

- ① (shaft pushed-in ←)

Shaft 79 261 314

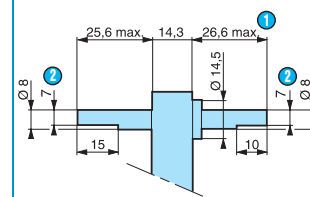

- ① (shaft pushed-in ←)
- ② 7 across flat

D.C. geared motors with brushes

→ 5 Nm 3.9 Watts

- A range of D.C. geared motors with solid metal gears.
Mechanical rating of gearbox with output shaft stalled : 5 Nm.
- 3.9 Watt motor versions.
- Available in either 12 or 24 V D.C.
- Gearbox ratios options for 1.7 to 344 rpm.
- Interference suppression on standard products



Specifications

		3.9 Watts	3.9 Watts
Type		82 867 0	82 867 0
Voltage		12 V	24 V
Output speed (rpm)	Ratios (i)		
344	12.5	82 867 001	82 867 007
258	50/3	•	•
172	25	82 867 002	82 867 008
103	125/3	82 867 003	82 867 009
69	62.5	82 867 004	82 867 010
34	125	82 867 005	82 867 011
17	250	•	•
8.6	500	82 867 006	82 867 012
1.72	2500	•	•
General characteristics			
Motor		82 860 0	82 860 0
Gearbox		81 037 0	81 037 0
Maximum permitted torque from gearmotor under continuous conditions (for 1 millions turns) N.m		5	5
Axial load dynamic (daN)		2	2
Radial load dynamic (daN)		3	3
Max. output (W)		3.9	3.9
Nominal output (W)		3	3
Gearbox case temperature rise (°C)		50	50
Weight (g)		465	465

Product adaptations

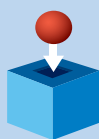

- Special supply voltages
- Special cable lengths
- Optional encoder
- Special connectors
- Special output shafts
- Special gearbox ratios
- Special gear wheel material
- Special output bearings
- Special mounting plate

To order, see page 13

Curves

The shaded zone represents the operating range of the geared motor.
The horizontal line marks the maximum torque available in continuous duty cycle for a given life.
For higher torque ratings, service life will be reduced.

Nominal speed and torque curves 82 867 0

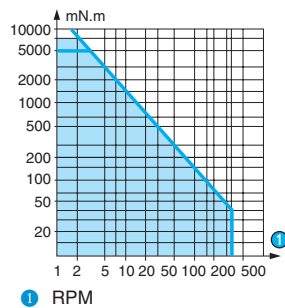

Dimensions

82 867 0

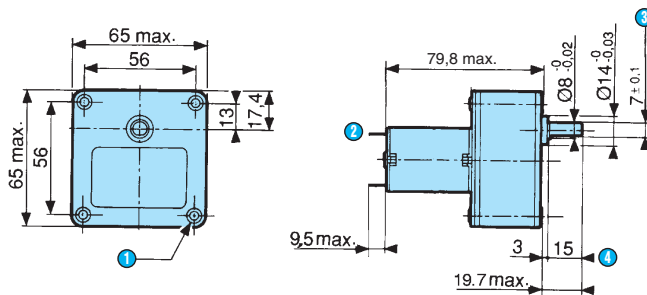

- 1 4 fixing holes $\text{Ø M4} \times 12 \text{ mm}$
- 2 2 tags NFC 20-120 series $2.8 \times 0.5 \text{ mm}$
- 3 $7 \text{ mm} \pm 0.1$ across flats
- 4 (shaft pushed-in ←)

Options

Shaft 79 206 478

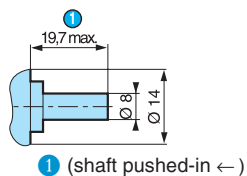

D.C. geared motors with brushes

→ 5 Nm 10 and 17 Watts

- A range of D.C. geared motors with solid metal gears.
Mechanical rating of gearbox with output shaft stalled : 5 Nm.
- 10 and 17 Watt motor power.
- Available in either 12, 24 or 48 V D.C.
- Gearbox ratios options for 10.5 to 616 rpm.



Specifications

		17 Watts	17 Watts	10 Watts	10 Watts
Type		80 805 0	80 805 0	80 815 0	80 815 0
Voltage		12 V	24 V	12 V	24 V
Standard speed (rpm)		2600 rpm	2600 rpm	2600 rpm	2600 rpm
Output speed (rpm)	Ratios (i)				
616	4.22	●	●	●	●
385	6.75	●	●	●	●
339.5	7.66	●	●	●	●
212	12.25	●	●	●	●
170	15.31	●	●	●	●
106	24.5	●	●	●	●
68	38.28	●	●	●	●
53	49	●	●	●	●
42.5	61.25	●	●	●	●
21	122.5	●	●	●	●
10.5	245	●	●	●	●
General characteristics					
Motor		82 800 0	82 800 0	82 810 0	82 810 0
Gearbox		81 035 0	81 035 0	81 035 0	81 035 0
Maximum permitted torque from gearmotor under continuous conditions (N.m)		5	5	5	5
Axial load dynamic (daN)		6	6	6	6
Radial load dynamic (daN)		6	6	6	6
Max. output (W)		16.3	17	10.3	9.5
Nominal output (W)		15.7	15.6	9.4	8.7
Gearbox case temperature rise (°C)		44	40	45	46
Weight (g)		920	920	820	820

Product adaptations

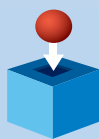

- Special supply voltages
- Special cable lengths
- Optional encoder
- Special connectors
- Special output shafts
- Special gearbox ratios
- Special gear wheel material
- Special output bearings
- Special mounting plate

To order, see page 13

Curves

The shaded zone represents the operating range of the geared motor.
The horizontal line marks the maximum torque available in continuous duty cycle for a given life.
For higher torque ratings, service life will be reduced.

Nominal speed and torque curves 80 805 0

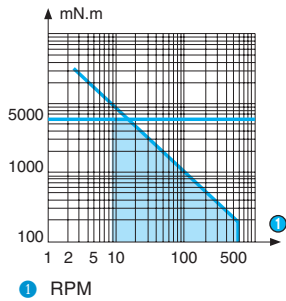

Nominal speed and torque curves 80 815 0

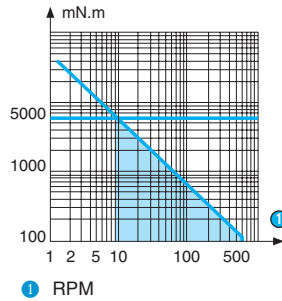

Dimensions

80 805 0

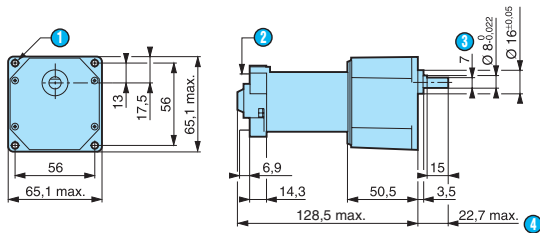

- ① 4 fixing holes $\text{Ø} 4.2$
- ② 2 tags IEC 760 series 4.8 x 0.5 mm
- ③ 7 mm ± 0.1 across flats
- ④ (shaft pushed-in \leftarrow)

80 815 0

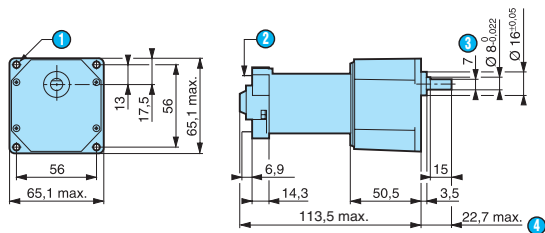

- ① 4 fixing holes $\text{Ø} 4.2$
- ② 2 tags IEC 760 series 4.8 x 0.5 mm
- ③ 7 mm ± 0.1 across flats
- ④ (shaft pushed-in \leftarrow)

Options

Gearbox shaft 79 290 064

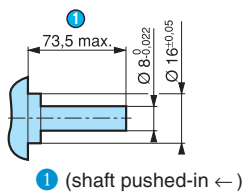

D.C. geared motors with brushes

→ 5 Nm 10 and 17 Watts

- A range of D.C. geared motors with solid metal gears. Mechanical rating of gearbox with output shaft stalled : 5 Nm.
- 10 and 17 Watt motor power.
- Available in either 12, 24 or 48 V D.C.
- Gearbox ratios options for 1 to 208 rpm.



Specifications

		17 Watts	17 Watts	10 watts	10 Watts
Type		80 807 0	80 807 0	80 817 0	80 817 0
Voltage		12 V	24 V	12 V	24 V
Output speed (rpm)	Ratios (i)				
208	12.5	80 807 012	80 807 018	•	•
156	50/3	•	•	•	•
104	25	80 807 013	80 807 019	•	•
62	125/3	80 807 014	80 807 020	•	•
42	62.5	80 807 015	80 807 021	•	•
21	125	80 807 016	80 807 001	•	•
10	250	•	•	•	•
5.20	500	80 807 017	80 807 022	•	•
1.04	2500	•	•	•	•
General characteristics					
Motor		82 800 0	82 800 0	82 810 0	82 810 0
Gearbox		81 037 0	81 037 0	81 037 0	81 037 0
Maximum permitted torque from gearmotor under continuous conditions for 1 millions turns (Nm)		5	5	5	5
Axial load dynamic (daN)		2	2	2	2
Radial load dynamic (daN)		3	3	3	3
Max. output (W)		16.3	17	10.3	9.5
Nominal output (W)		15.7	15.6	9.4	8.7
Gearbox case temperature rise (°C)		44	40	45	46
Weight (g)		800	800	710	710

Product adaptations

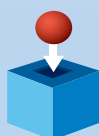

- Special supply voltages
- Special cable lengths
- Optional encoder
- Special connectors
- Special output shafts
- Special gearbox ratios
- Special gear wheel material
- Special output bearings
- Special mounting plate

To order, see page 13

Curves

The shaded zone represents the operating range of the geared motor.
The horizontal line marks the maximum torque available in continuous duty cycle for a given life.
For higher torque ratings, service life will be reduced.

Nominal speed and torque curves 80 807 0

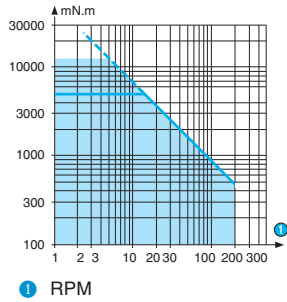

Nominal speed and torque curves 80 817 0

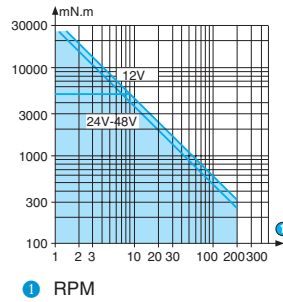

Dimensions

80 807 0

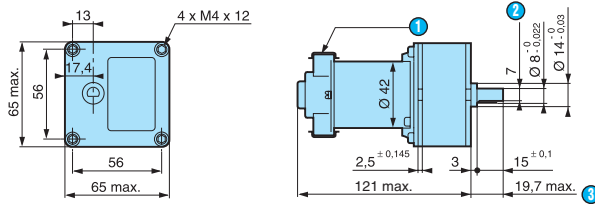

- 1 2 tags IEC 760 series 4.8 x 0.5 mm
- 2 7 mm across flats
- 3 (shaft pushed-in ←)

80 817 0

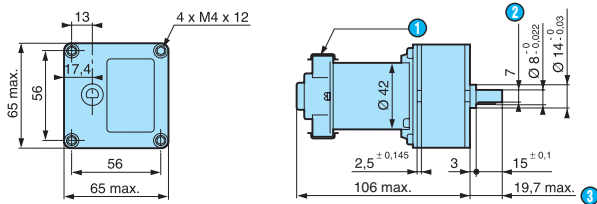

- 1 2 tags IEC 760 series 4.8 x 0.5 mm
- 2 7 mm across flats
- 3 (shaft pushed-in ←)

Options

Gearbox shaft 79 206 478

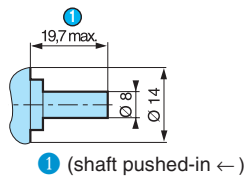

D.C. geared motors with brushes

→ 5 Nm 33 Watts

- A range of D.C. geared motors with solid metal gears.
Mechanical rating of gearbox with output shaft stalled : 5 Nm.
- 33 Watt motor power.
- Available in either 12, 24 or 48 V D.C.
- Gearbox ratios options for 7.4 to 426 rpm.



Specifications

		33 Watts	33 Watts
Type		80 835 0	80 835 0
Voltage		12 V	24 V
Standard speed (rpm)		1800 rpm	1800 rpm
Output speed (rpm)	Ratios (i)		
426	4.22	●	●
266	6.75	●	●
235	7.66	●	●
147	12.25	●	●
118	15.31	●	●
73	24.5	●	●
47	38.28	●	●
37	49	●	●
29.4	61.25	●	●
14.7	122.5	●	●
7.4	245	●	●
General characteristics			
Motor		82 830 0	82 830 0
Gearbox		81 035 0	81 035 0
Maximum permitted torque from gearmotor under continuous conditions (N.m)		5	5
Axial load dynamic (daN)		6	6
Radial load dynamic (daN)		6	6
Max. output (W)		33	33
Nominal output (W)		27	27
Gearbox case temperature rise (°C)		50	50
Weight (g)		1540	1540

Product adaptations

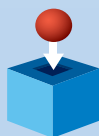

- Special supply voltages
- Special cable lengths
- Optional encoder
- Special connectors
- Special output shafts
- Special gearbox ratios
- Special gear wheel material
- Special output bearings
- Special mounting plate

To order, see page 13

Curves

The shaded zone represents the operating range of the geared motor.
The horizontal line marks the maximum torque available in continuous duty cycle for a given life.
For higher torque ratings, service life will be reduced.

Nominal speed and torque curves

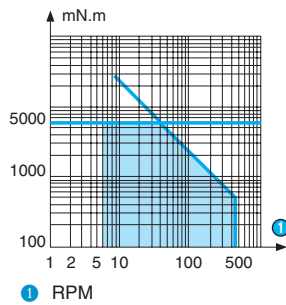

Dimensions

80 835 0

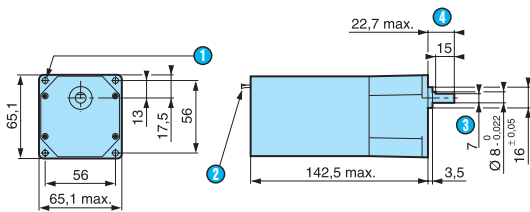

- ① 4 fixing holes $\text{\O} 4.2$
- ② Lead length $200 \text{ mm} \pm 10$
- ③ 7 mm across flats
- ④ (shaft pushed-in \leftarrow)

Options

Gearbox shaft 79 290 064

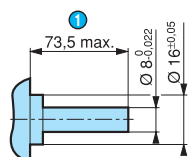

- ① (shaft pushed-in \leftarrow)

D.C. geared motors with brushes

→ 5 Nm 42 to 52 Watts

- A range of D.C. geared motors with solid metal gears.
Mechanical rating of gearbox with output shaft stalled : 5 Nm.
- 40 to 52 Watt motor versions.
- Available in either 12 or 24 V D.C.
- Gearbox ratios options for 13.8 to 805 rpm.



Specifications

		42 Watts	52 Watts
Type		80 855 0	80 855 0
Voltages		12 V	24 V
Standard speed (rpm)		3400 rpm	3400 rpm
Output speed (rpm)	Ratios (i)		
805	4.22	●	●
503	6.75	●	●
444	7.66	●	●
277	12.25	●	●
222	15.31	●	●
139	24.5	●	●
89	38.28	●	●
69	49	●	●
55	61.25	●	●
28	122.5	●	●
13.8	245	●	●
General characteristics			
Motor		82 850 0	82 850 0
Gearbox		81 035 0	81 035 0
Maximum permitted torque from gearmotor under continuous conditions (2.5 million revolution) (N.m)		5	5
Axial load dynamic (daN)		6	6
Radial load dynamic (daN)		6	6
Max. output (W)		42	52
Nominal output (W)		32	32
Gearbox case temperature rise (°C)		45	45
Weight (g)		985	985

Product adaptations

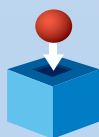

- Special supply voltages
- Special cable lengths
- Optional encoder
- Special connectors
- Special output shafts
- Special gearbox ratios
- Special gear wheel material
- Special output bearings
- Special mounting plate

To order, see page 13

Curves

The shaded zone represents the operating range of the geared motor.
The horizontal line marks the maximum torque available in continuous duty cycle for a given life.
For higher torque ratings, service life will be reduced.

Nominal speed and torque curves

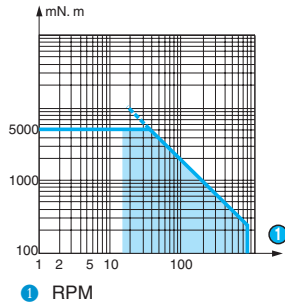

Dimensions

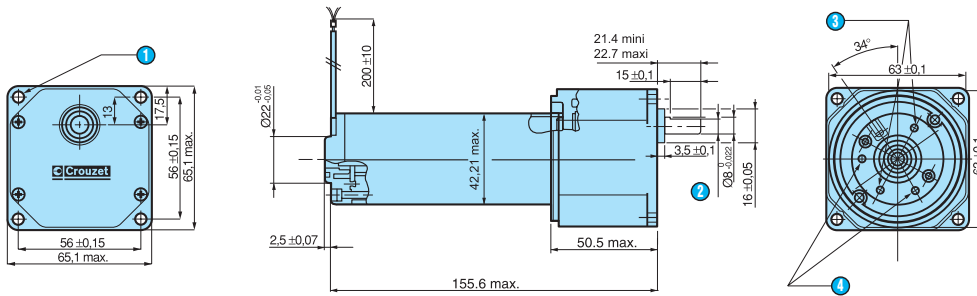

- 1 4 fixing holes $\text{\O} 4.2$
- 2 7 mm ± 0.1 across flats
- 3 2 holes M3 x 0.5 at 180° depth 4 on $\text{\O} 32$
- 4 2 holes 2.5 ± 0.5 at 120° depth 4.5 on $\text{\O} 32$

D.C. geared motors with brushes

→ 6 Nm 10 and 17 Watts

- A range of D.C. geared motors with solid metal gears.
Mechanical rating of gearbox with output shaft stalled : 6 Nm.
- 10 and 17 Watt motor power.
- Available in either 12, 24 or 48 V D.C.
- Gearbox ratios options for 4 to 12 rpm.



Specifications

		10 Watts	10 Watts	17 Watts	17 Watts
Type		82 812 5	82 812 5	82 802 5	82 802 5
Voltage		12 V	24 V	12 V	24 V
Standard speed (rpm)		2600	2600	2600	2600
Output speed (rpm)	Ratios (i)				
12	650/3	●	●	●	●
8	338	●	●	●	●
4	650	●	●	●	●
General characteristics					
Motor		82 810 0	82 810 0	82 800 0	82 800 0
Gearbox		81 032 6	81 032 6	81 032 6	81 032 6
Maximum permitted torque from gearmotor under continuous conditions for 10 millions turns (Nm)		6	6	6	6
Axial load dynamic (daN)		3.5	3.5	3.5	3.5
Radial load dynamic (daN)		5	5	5	5
Max. output (W)		10.3	9.5	16.3	17
Nominal output (W)		9.4	8.7	15.7	15.6
Gearbox case temperature rise (°C)		45	46	44	40
Weight (g)		880	880	880	880

Product adaptations

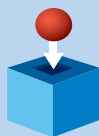

- Special supply voltages
- Special cable lengths
- Optional encoder
- Special connectors
- Special output shafts
- Special gearbox ratios
- Special gear wheel material
- Special output bearings
- Special mounting plate

To order, see page 13

Curves

The shaded zone represents the operating range of the geared motor.
The horizontal line marks the maximum torque available in continuous duty cycle for a given life.
For higher torque ratings, service life will be reduced.

Nominal speed and torque curves 82 812 5

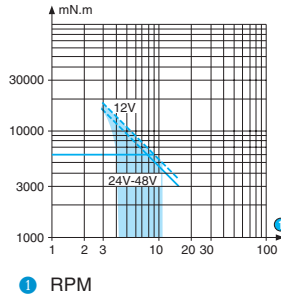

Nominal speed and torque curves 82 802 5

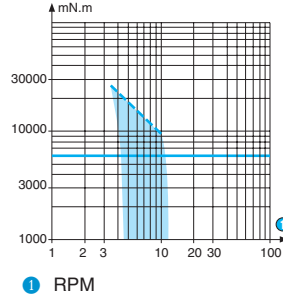

Dimensions

82 812 5

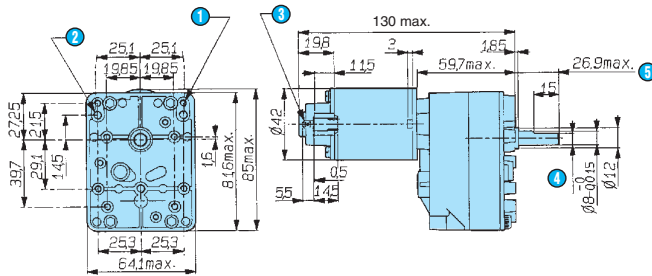

- 1 8 holes M4 depth 7.5 mm
- 2 3 holes M5 at 120° depth 7.5 mm
- 3 2 tags IEC 760 series 4.8 x 0.5 mm
- 4 7 mm across flats
- 5 (shaft pushed-in ←)

82 802 5

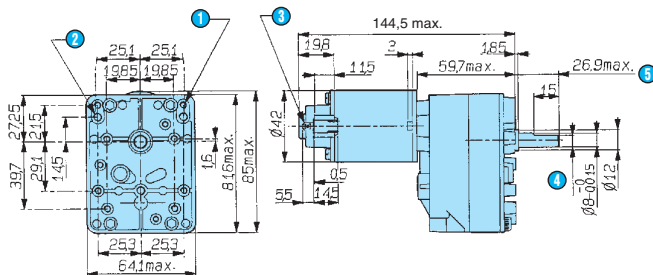

- 1 8 holes M4 depth 7.5 mm
- 2 3 holes M5 at 120° depth 7.5 mm
- 3 2 tags IEC 760 series 4.8 x 0.5 mm
- 4 7 mm across flats
- 5 (shaft pushed-in ←)

D.C. geared motors with brushes

→ 6 Nm 33 Watts

- A range of D.C. geared motors with solid metal gears.
Mechanical rating of gearbox with output shaft stalled : 6 Nm.
- 33 Watt motor power.
- Available in either 12, 24 or 48 V D.C.
- Gearbox ratios options for 5 to 14 rpm.



Specifications

		33 Watts	33 Watts
Type		82 832 5	82 832 5
Voltages		12 V	24 V
Output speed (rpm)	Ratios (i)		
14	130	•	•
8	650/3	•	•
5	338	•	•
General characteristics			
Motor		82 830 0	82 830 0
Gearbox		81 032 6	81 032 6
Maximum permitted torque from gearmotor under continuous conditions for 10 millions turns (Nm)		6	6
Axial load dynamic (daN)		3.5	3.5
Radial load dynamic (daN)		5	5
Max. output (W)		33	33
Nominal output (W)		27	27
Gearbox case temperature rise (°C)		50	50
Weight (g)		1400	1400

Product adaptations

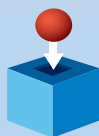

- Special supply voltages
- Special cable lengths
- Optional encoder
- Special connectors
- Special output shafts
- Special gearbox ratios
- Special gear wheel material
- Special output bearings
- Special mounting plate

To order, see page 13

Curves

The shaded zone represents the operating range of the geared motor.
The horizontal line marks the maximum torque available in continuous duty cycle for a given life.
For higher torque ratings, service life will be reduced.

Nominal speed and torque curves

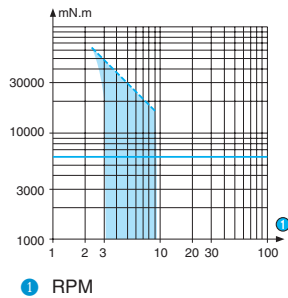

Dimensions

82 832 5

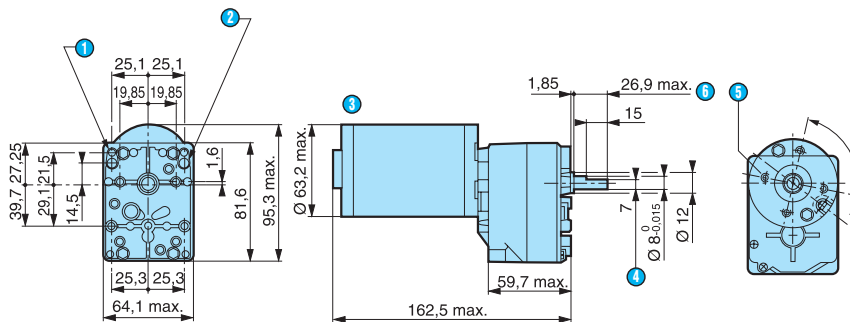

- ① 3 holes M5 at 120° depth 7.5 mm
- ② 8 holes M4 depth 7.5 mm
- ③ Lead length 200 mm
- ④ 7 mm across flats
- ⑤ 4 holes M5 on Ø 40 depth 7 mm
- ⑥ (shaft pushed-in ←)

D.C. geared motors with brushes

→ 15 Nm 22 to 42 Watts

- Gearbox torque rating : 0.8 to 25 Nm.
- Associated DC motors : 15 to 90 watts.
- DC planetary geared motors with brushes
- Speed range : 11 to 454 rpm.



Specifications

			22 Watts	42 Watts
Type			80 809 2	80 859 3
Voltages			12 V or 24 V	12 V or 24 V
Number of stages	Speed (rpm)	Ratios		
1	454	6.75	●	
	477	6.75		●
	122	25.0	●	
2	128	25.0		●
	69	46	●	
	70	46		●
3	33	93	●	
	34	93		●
	20	169	●	
	19	169		●
	12	308	●	
	11	308		●
General characteristics				
Motor			82 800 5	82 850 0
Gearbox			81 049 2	81 049 3
Max. torque Nm			0.8 (1 stage) 2 (2 stages) 4 (3 stages)	3 (1 stage) 7.5 (2 stages) 15 (3 stages)
Efficiency (%)			0.75 (1 stage) 0.7 (2 stages) 0.65 (3 stages)	0.8 (1 stage) 0.75 (2 stages) 0.7 (3 stages)
Radial load (dynamic) daN			1.5 (1 stage) 3 (2 stages) 4.5 (3 stages)	16 (1 stage) 23 (2 stages) 30 (3 stages)
Axial load dynamic (daN)			0.5 (1 stage) 1 (2 stages) 1.5 (3 stages)	5 (1 stage) 8 (2 stages) 11 (3 stages)
Output ball bearing			No	Yes
Sintered bronze output bearing			Yes	No

Product adaptations

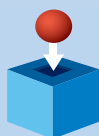

- Special supply voltages
- Special cable lengths
- Optional encoder
- Special connectors
- Special output shafts
- Special gearbox ratios
- Special gear wheel material
- Special output bearings
- Special mounting plate

To order, see page 13

Curves

80 809 2

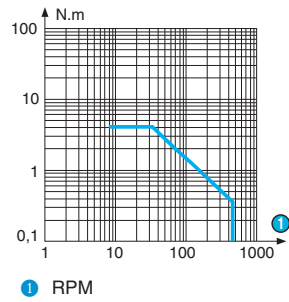

80 859 3

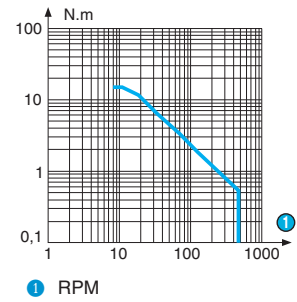

Dimensions

80 809 2

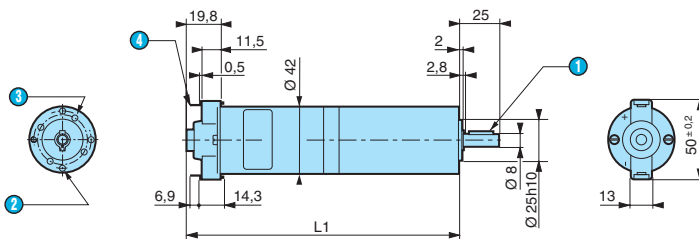

- ① Key 3 x 3 x 16
- ② 4 M4 x 10 on Ø 36
- ③ 4 holes for M3 self-tapping screws on Ø32, depth 10
- ④ 2 tags 4.75

L1 1 stage : 134 mm
 L1 2 stages : 147 mm
 L1 3 stages : 160 mm

80 859 3

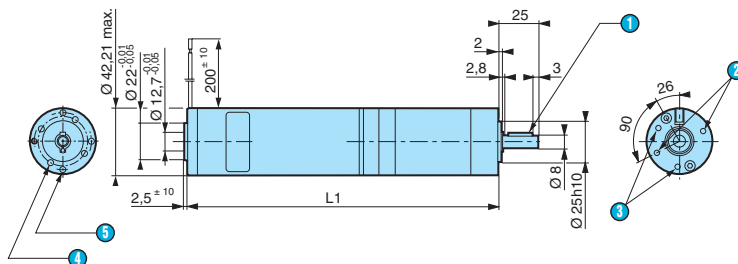

- ① Key 3 x 3 x 16
- ② 2 M3 x 0.5 at 180° depth 5.5 on Ø32
- ③ 2 M3 x 0.5 at 120° depth 5.5 on Ø32
- ④ 4 M4 x 10 on Ø36
- ⑤ 4 M3 x 10 on Ø32

L1 1 stage : 162 mm
 L1 2 stages : 175 mm
 L1 3 stages : 188 mm

D.C. geared motors with brushes

→ 25 Nm 67 to 195 Watts

- Gearbox torque rating : 0.8 to 25 Nm.
- Associated DC motors : 15 to 90 watts.
- DC planetary geared motors with brushes
- Speed range : 11 to 454 rpm.



Specifications

			67 Watts	195 Watts
Type			80 839 4	80 899 5
Voltages			12 V or 24 V	24 V
Number of stages	Speed (rpm)	Ratios		
1	410	6.75	●	
	474	6.75		●
	110	25.0	●	
2	128	25.0		●
	62	46	●	
	70	46		●
3	30	93	●	
	34	93		●
	18	169	●	
	19	169		●
	11	308	●	
	11	308		●
General characteristics				
Motor			82 830 5	82 890 0
Gearbox			81 049 4	82 849 5
Max. torque Nm			2 (1 stage) 5 (2 stages) 10 (3 stages)	4 (1 stage) 12 (2 stages) 25 (3 stages)
Efficiency (%)			0.75 (1 stage) 0.7 (2 stages) 0.65 (3 stages)	0.8 (1 stage) 0.75 (2 stages) 0.7 (3 stages)
Radial load (dynamic) daN			20 (1 stage) 32 (2 stages) 45 (3 stages)	20 (1 stage) 32 (2 stages) 45 (3 stages)
Axial load dynamic (daN)			6 (1 stage) 10 (2 stages) 15 (3 stages)	6 (1 stage) 10 (2 stages) 15 (3 stages)
Output ball bearing			Yes	Yes
Sintered bronze output bearing			No	No

Product adaptations

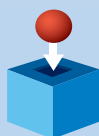

- Special supply voltages
- Special cable lengths
- Optional encoder
- Special connectors
- Special output shafts
- Special gearbox ratios
- Special gear wheel material
- Special output bearings
- Special mounting plate

To order, see page 13

Curves

80 839 4

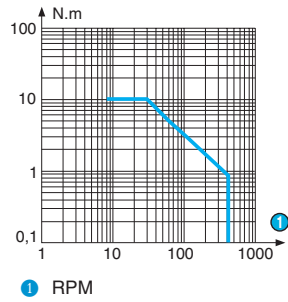

80 899 5

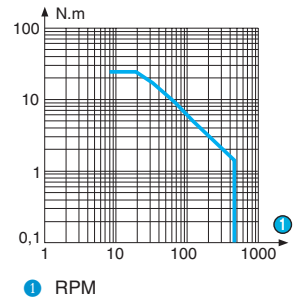

Dimensions

80 839 4

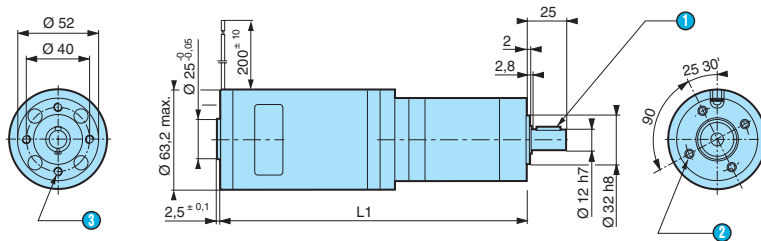

- ① Key 4 x 4 x 16
- ② 4 M5 x 0.86 h depth 7 on $\varnothing 40$
- ③ 4 M5 x 10

L1 1 stage : 159 mm
 L1 2 stages : 173 mm
 L1 3 stages : 187 mm

80 899 5

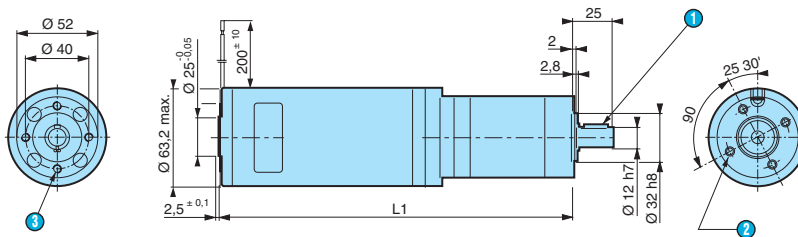

- ① Key 4 x 4 x 16
- ② 4 M5 x 0.86 h depth 7 on $\varnothing 40$
- ③ 4 M5 x 10

L1 1 stage : 184 mm
 L1 2 stages : 198 mm
 L1 3 stages : 212 mm



D.C. brushless motors

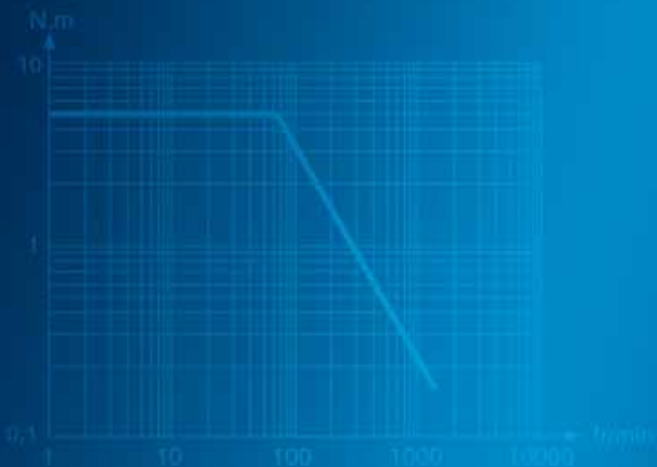

Guide to selecting Brushless D. C. motors

Right angle gearbox

Gearbox	Max. torque (Nm)			0.6	1	1.7
	Motors direct drive (Nm)			30 W		
Usable Power (W)	Nominal torque (Nm)	Nominal speed (rpm)	Supply voltage (V)	Motor type dimensions (mm)		
30	140	2200	24	▶p.76 80 140 57x57	▶p.80 80 141 440 rpm	▶p.80 80 141 220 rpm
80	240	3250	24	▶p.78 80 180 57x57		▶p.82 80 181 650 rpm
					▶p.80 80 141 110 rpm	▶p.82 80 181 325 rpm

Planetary gearbox

Gearbox	Max. torque (Nm)			0.8	1	4.5
	Motors direct drive (Nm)			30 W		
Usable Power (W)	Nominal torque (Nm)	Nominal speed (rpm)	Supply voltage (V)	Motor type dimensions (mm)		
30	140	2200	24	▶p.76 80 140 57x57	▶p.81 80 149 Ø 62	
80	240	3250	24	▶p.78 80 180 57x57		▶p.83/84 80 189 Ø 81
					316 rpm	▶p.83/84 80 189 120 rpm
					650 rpm	

Choice of gearbox according to mechanical criteria

Right angle	Perpendicular output Silence (<53 dB) Non-reversible from R = 30	Planetary	Output in shaft Increased efficiency Reversible
--------------------	--	------------------	---

Choice of power according to available torque and electronic performance

Electronics 30 watts	Speed regulation 1-channel encoder (12 points/rev) NPN type outputs	Electronics 80 Watt	Speed and torque regulation 2-channel encoder (12 points/rev + direction) PNP type output
-----------------------------	--	----------------------------	--

2	2.1	2.9	3.4	3.5
----------	------------	------------	------------	------------

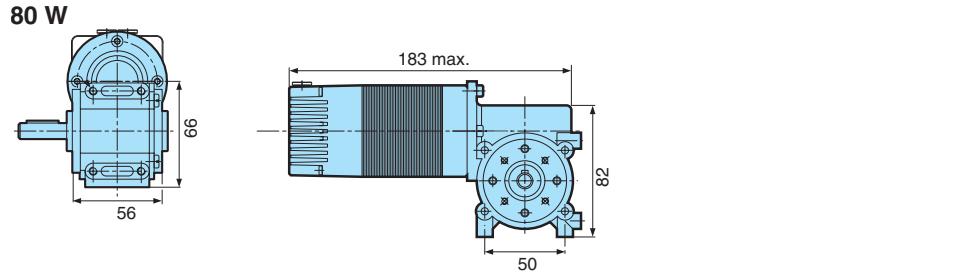

p.80	80 141	p.80	80 141						
44 rpm		74 rpm		p.82	80 181	p.82	80 181	p.82	80 181
				163 rpm		65 rpm		108 rpm	

2

5	20	30
----------	-----------	-----------

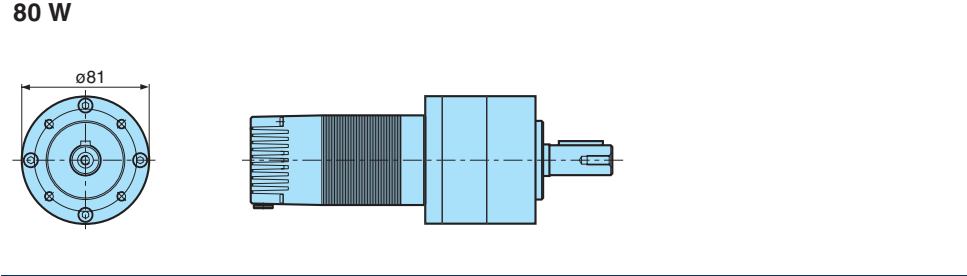

p.81	80 149	p.81	80 149		
Ø 62		Ø 62			
48 rpm		48 rpm			
		p.83/84	80 189		
		Ø 81			
		23 rpm			

Selection of a geared motor

A geared motor is selected according to the required usable power output.

$$\text{UsablePower} = \frac{2\pi}{60} C \cdot n$$

(W) (Nm) (rpm)

A geared motor must have usable power equal to or greater than the power required to rotate the load. It is selected by checking that the point corresponding to the required operating conditions (torque and speed output) is higher than the nominal torque versus speed curve of the geared motor. The required torque output of a geared motor must be within its maximum recommended torque for continuous duty.

Basic concepts

Brushless motors and geared motors

Principle

1.1. Composition of the driving part:

Brushless motors comprise 3 main elements:

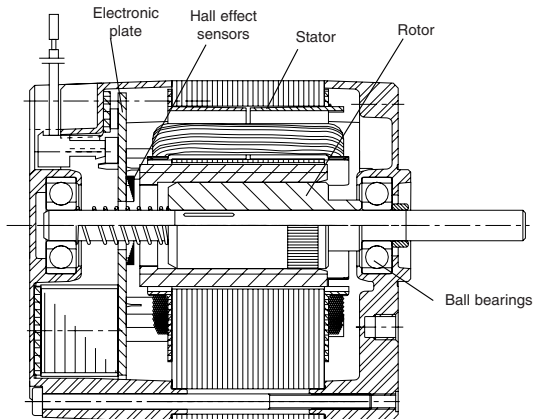

- A fixed part, the stator, which has three groups of coils, called the three phases of the motor. These coils operate as electromagnets and generate various orientations of magnetic field regularly distributed around the central shaft of the motor.

- A rotating part, the rotor, which has permanent magnets. Like the needle of a compass, these magnets permanently drive the rotor to try to align itself with the magnetic field of the stator. For optimum service life of the motor, the rotor is mounted on ball bearings.

- Three "Hall effect" magnetic sensors. These sensors provide information on the position of the rotor magnets at all times.

1.2. The integrated control electronics:

Crouzet brushless motors incorporate their control electronics as standard. The control electronics control the phases of the motor, regulate the speed and incorporate the encoder function.

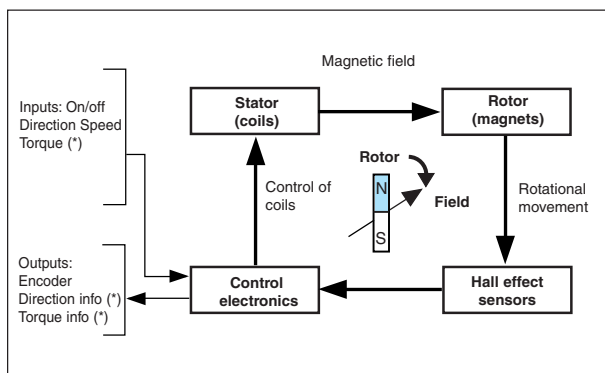

- The control electronics determine the position of the rotor using the Hall effect sensors. The electronics deduce from the sensors the orientation to give to the magnetic field of the stator. During rotation, they control the three coils to regularly adjust the orientation of the field to the position of the rotor, in order to drive it in the direction chosen by the user.

- By modulating the current in the coils, the electronics can accelerate or slow down the motor and thus regulate its speed. They can also orient the magnetic field in order to brake the movement of the rotor to bring it to a standstill.

- By limiting the current in the coils, the electronics can also limit the torque of the motor, and activate the corresponding output

- The electronics also generate the outputs of the built-in encoder using the Hall effect sensors.

Speed regulation

2.1. What is 4-quadrant regulation?

The four zones of a torque/speed diagram are known as 'quadrants':

- A positive speed represents clockwise rotation, and a negative speed anti-clockwise

- A positive torque represents motor operation, and a negative torque brake operation.

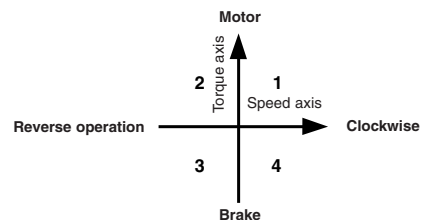

1-quadrant regulation operates in a single direction of rotation, with no possibility of braking. In the event of overspeed, the regulator cuts off the current until the motor is braked by the load

The principle is identical for 2-quadrant regulation, but in both directions of rotation. This operating mode is offered as an option on Crouzet brushless motors, when required by a specific application.

4-quadrant regulation also operates in both directions of rotation, but also allows braking. In the event of overspeed, the motor is involved in the braking and the system quickly loses speed.

All Crouzet brushless motors have 4-quadrant regulation as standard.

2.2. Braking:

Braking means absorbing the energy of the mechanical system. There are several different types of braking, depending on the use made of this absorbed energy:

Regenerative braking converts the energy of the system into electrical current, which will be directed to the motor power supply.

Apart from batteries, most commercially available power supplies do not accept this type of current feedback (they are known as 'non-reversible'). It is therefore necessary to ensure that the directed current can be consumed by another device, without which the power supply may be damaged. This braking mode is offered as an option on Crouzet brushless motors, but must be used with caution.

Crouzet brushless motors have braking 'without energy rejection' as standard. This means that on braking the kinetic energy of the system is converted into heat inside the motor itself, with no feedback to the power supply. This is the most suitable type of braking for most applications.

However, if there is prolonged braking, the heat that is generated may trip the thermal protection of the motor. For high inertia applications, or operation as a generator, PLEASE CONSULT CROUZET. Depending on the circumstances, our specialists will advise you to select either 2-quadrant regulation, or braking with energy rejection.

2.3. Control by PWM

PWM (Pulse Width Modulation) control is a method of indicating the speed setpoint to the motor. A PWM control motor should be chosen in the following cases:

- Control by CROUZET Millenium II logic controllers (see MOTOMATE information)
- Control by PLC with PWM outputs
- Control by digital control system

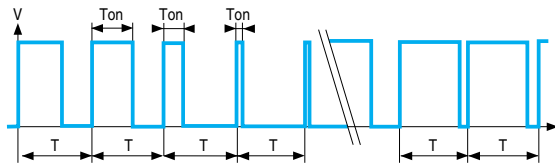

PWM control consists of pulse trains of fixed frequency (Period "T") but variable width ("Ton" period of the pulse). The speed setpoint depends on the Ton/T ratio. However it is independent of the voltage or frequency of the pulses, within the limits of the stated specifications.

Ton/T = 0%	Speed setpoint = 0
Ton/T = 100%	Speed setpoint = No-load speed of the motor
Ton/T = 50%	Speed setpoint = No-load speed of the motor/2

2.4. Control by 0-10V

0-10V voltage control is the other method of indicating the speed setpoint to the motor. A 0-10V input motor should be chosen in the following cases:

- Control by potentiometer
- Control by PLC with analogue converter outputs
- Control by analogue control system

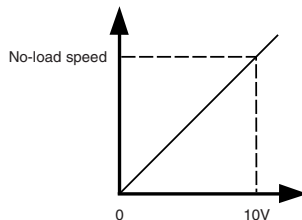

In this type of control, the speed setpoint depends on the voltage U at the speed setpoint input:

U = 0	Speed setpoint = 0
U = 10V	Speed setpoint = No-load speed of the motor
U = 5V	Speed setpoint = No-load speed of the motor/2

Torque limiting (*)

3.1. Operation

Torque limiting is used to deliberately check the motor at certain moments in the operation of a system:

- If there is a risk of encountering an end stop or jamming, to prevent damage to the system
- To maintain a force when the system is at an end stop
- To control the tension of an element located between two moving motor

3.2. Torque limiting input (*)

This input can be controlled in 0-10V and in PWM, whatever type of speed control is selected (Input impedance 16 k ohms. Minimum PWM voltage 12 volts.

Frequency range 150 Hz - 1 kHz

- When the input is at 0 or not connected, the motor delivers up to 140% of its nominal torque
- When the input is at maximum (100% PWM or 10V), the motor delivers around 30% of its nominal torque

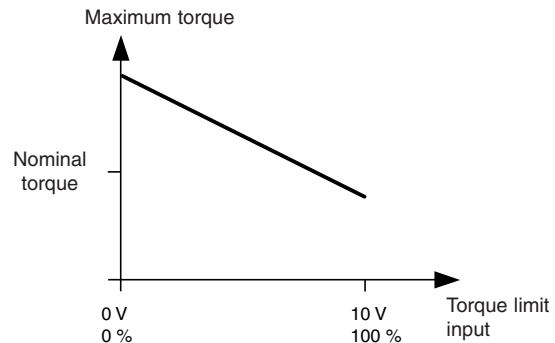

When the torque limit is reached, the motor does not follow its speed setpoint, but maintains a constant torque equal to this limit, as long as its speed remains below the setpoint.

3.3. Limit reached alert output (*)

This output is at logic state 1 when the torque limit is reached.

IMPORTANT: This output is PNP type. Consult the wiring diagrams and the precautions for use of this output in the motor specifications.

Built-in protection

4.1. 30 watt motors

If the motor locks when it is controlled, a protection system cuts off the power after a few seconds.

The motor can only restart when the On input changes to 0 then 1.

4.2. 80 watt motors

A temperature sensor incorporated in the motor switches the motor to safety mode when the temperature exceeds a value which may damage it. When the trigger temperature is reached, the power is cut off, which causes the motor to stop.

It can only restart when the temperature has fallen below the restart temperature and the On input has changed to 0 then 1.

Direction and on/off controls

Input logic table

On	Direction	Speed	Action
0	X	X	Braking and stop
1	X	0	Braking and stop
1	1	V	Clockwise direction at speed V
1	0	V	Anti-clockwise direction at speed V

On and Direction inputs:
 - Input impedance: 60 Ω
 - Logic state 0: < 2V
 - Logic state 1: > 4V

Built-in encoder

The built-in encoder supplies fixed width pulses each time a Hall effect sensor switches. These pulses can be counted to ascertain the speed and position of the motor, or filtered to obtain an analogue signal proportional to the speed.

The additional direction of rotation (*) output is used to determine the direction of count of the pulses.

IMPORTANT: These outputs are NPN or PNP type depending on the version. Consult the wiring diagrams and the precautions for use of these outputs in the motor specifications.

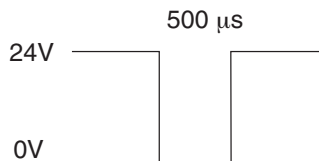

Safety

Crouzet BRUSHLESS DC motors are designed and manufactured to be integrated into appliances or machines which meet, for example, the specifications of the machine standard: EN 60335-1 (IEC 335-1, "Safety of household and similar electrical appliances").

The integration of Crouzet DC motors into appliances or machines should generally take account of the following motor characteristics:

- no earth connection
- "simple isolation" motors
- protection index: IP54
- insulation system class: B (120 °C)
- Vibration: EN 60068.2.6: 5G from 55 Hz to 500 Hz/0.35 mm peak to peak from 10 Hz to 55 Hz
- Shock: IEC 60068.2.27: 1/2 sine 50G for 11 ms

European low voltage directive 73/23/EEC of 19/02/73:

Crouzet DC motors and geared motors are outside the scope of this directive (LVD 73/23/EEC applies to voltages over 75 volts DC).

IMPORTANT

■ Product operation:

To ensure correct operation of Brushless actuators, it is advisable to take account of all the necessary installation and wiring precautions.

■ Product characteristics:

The stated nominal operating characteristics correspond to the voltage-torque-speed characteristics which permit continuous operation, at an ambient temperature of 40 °C. Above these operating conditions, only intermittent duty cycles will be possible: without exception, where extreme conditions prevail, all checks should be performed by the customer in the real-life context of the application to ensure safe operation. For operation in non-nominal conditions:

-> available on request

■ Product usage:

If these products are being used in very specific operating conditions:
 - food and beverage (eg: non-continuous, rectified)
 - ambient atmosphere (extreme temperatures and vibrations, significant relative humidity, explosive or confined atmosphere, etc)
 - other (use as load, sudden stalling, severe operating cycle, etc):
 -> available on request

EMC compatibility

On request, Crouzet will provide the EMC characteristics of the various types of product.

European directive 89/336/EEC of 03/05/89, "electromagnetic compatibility":

DC motors and geared motors which are components designed for professionals to be incorporated in more complex devices, and not for end users, are excluded from the scope of this directive.

However, conscious of the potential customer difficulties concerning problems connected with electromagnetic compatibility, Crouzet has designed its products to meet the requirements of the standards: for example EN 55011 Gr. 1 class B (medical) and also EN 55022, class B (data processing) in terms of emitted electromagnetic interference, in addition to standards connected with immunity:

IEC 1000- 4 -2/3/4/5/6/8

■ Wiring precautions

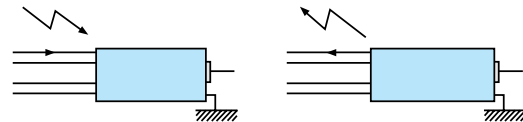

For EMC conformity:

- The motor should be connected to earth via its front flange.
- The length of the wires is 0.5 m max.

(*) Note: Functions marked with an asterisk are only available on the 80 watt versions. If they are required on 30 watt motors, please consult Crouzet.

■ Electromagnetic compatibility:

Emission

- Conducted emissions: EN 55022/11G1 class B
- Radiated emissions: EN 55022/11G1 class B

Immunity

- Electrostatic discharges: EN 61000-4-2 Level 3
- Electromagnetic fields: EN 61000-4-3 level 3
- Pulse trains: EN 61000-4-4 level 3
- Shock waves: EN 61000-4-5 level 2
- Radio frequency: EN 61000-4-6 level 3
- Magnetic field: EN 61000-4-8 level 4
- Voltage dips: EN 61000-4-29

(*) Note: Functions marked with an asterisk are only available on the 80 watt versions. If they are required on 30 watt motors, please consult Crouzet.

Direct drive BRUSHLESS DC motors

→ 30 Watts

- Ideal for movement and positioning applications**
Adjustable : 4 quadrant variable speed control
- Complete : Brake, 2 channel encoder and integrated EMC filter
 - Compact : High efficiency and starting torque
 - Open : Compatible with Crouzet Millenium II+ logic controller
 - Flexible : 24 V supply allows battery operation



Specifications

	30 Watts
Speed control	0-10 V and PWM
Part numbers	80 140 004
Supply voltage (V)	24 (18 → 28)
No-load characteristics	
Speed of rotation (rpm)	3 100
Absorbed current (A)	0.2
Nominal characteristics	
Speed (rpm)	2 200
Torque (mN.m)	140
Absorbed current (A)	1.9
Maximum characteristics	
Start torque (mN.m)	220
Starting current (A)	3.0
General characteristics	
Insulation class (conforming to IEC 85)	B (120°C)
Casing temperature rise at 40°C ambient max. (°C)	15
Thermal time constant (min)	15
Inertia (g.cm ²)	50
Weight (g)	800
Acoustic pressure at 50 cm (dBA)	40
Service life L10 (h)	20 000
0-10 V speed input characteristics	
Input impedance (kΩ)	10
Full scale speed (rpm)	3 100
PWM speed input characteristics	
Input impedance (kΩ)	10
Level 0 input voltage (V)	< 1.7
Level 1 input voltage (V)	> 3
Frequency range (Hz)	150 → 5 000
Full scale speed (rpm)	3 100
Output characteristics	
Type of output	NPN
Max. current (mA)	50

Product adaptations

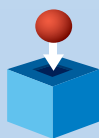

- 2 quadrant speed regulation,
- Motors with hall effect sensors only,
- Adaptations on electronics,
- Special cable lengths,
- Special connectors fitted to the cable.

To order, see page 13

Curves

Speed/torque

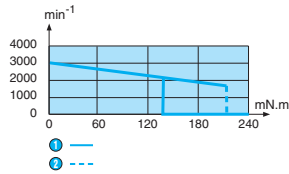

- 1 Continuous operation
- 2 Cyclic operation

Current/torque

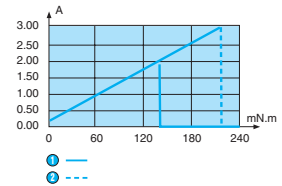

- 1 Continuous operation
- 2 Cyclic operation

Dimensions

Version IP 54

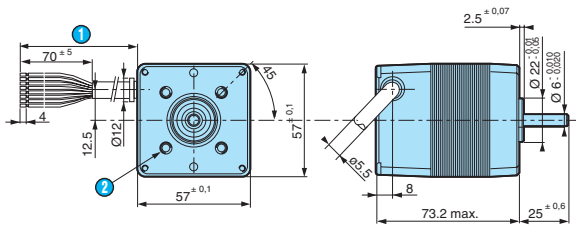

- 1 Cable length : 400 ± 10 mm
- 2 4 holes M5 x 0.86 H on $\varnothing 40$ depth 4.5 mm mini

Connections

Marking on motor	Function	Wire colour	
*a	Power earth	Black	
*a	24 V power supply	Red	
	Signal earth	Blue	
	On/off input	Green	1 power cable
	Direction input	Yellow	AWG24
	PWM speed setpoint	Orange	8 conductors
	0-10 V speed setpoint	Brown	UL2464
*b	12 points/rev encoder output	Purple	

Applications

Examples of encoder output cabling (purple)

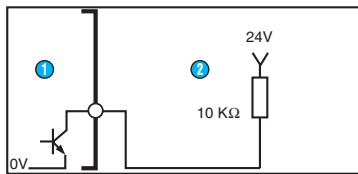

- 1 Motor
- 2 Resistive load

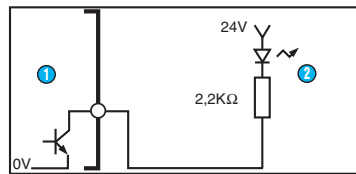

- 1 Motor
- 2 LED load

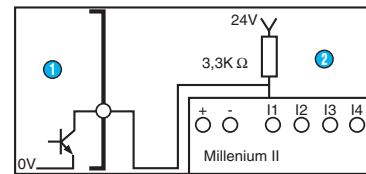

- 1 Motor
- 2 Millenium II+

User information

- *a) Do not invert the polarities
- *b) Do not short-circuit the encoder output (NPN)
Do not use the motor as a generator

Direct drive BRUSHLESS DC motors

→ 80 Watts

- Ideal for movement and positioning applications
Adjustable : 4 quadrant variable speed control
- Complete : Brake, 2 channel encoder and integrated CEM filter
 - Compact : High efficiency and starting torque
 - Open : Compatible with Crouzet Millennium II+ logic controller
 - Flexible : 24 V supply allows battery operation



Specifications

	80 Watts PWM control	80 Watts 0-10 V control
Speed control	PWM	0-10 V
Part numbers	80 180 001	80 180 002
Supply voltage (V)	24 (18 → 37)	24 (18 → 37)
No-load characteristics		
Speed of rotation (rpm)	4 200	4 200
Absorbed current (A)	0.4	0.4
Nominal characteristics		
Speed (rpm)	3 250	3 250
Torque (mN.m)	240	240
Absorbed current (A)	4.8	4.8
Maximum characteristics		
Start torque (mN.m)	300	300
Starting current (A)	6.0	6.0
General characteristics		
Insulation class (conforming to IEC 85)	B (120°C)	B (120°C)
Casing temperature rise at 40°C ambient max. (°C)	20	20
Thermal time constant (min)	15	15
Inertia (g.cm ²)	105	105
Acoustic pressure at 50 cm (dBA)	50	50
Service life L10 (h)	20 000	20 000
0-10 V speed input characteristics		
Input impedance (kΩ)	-	440
Full scale speed (rpm)	-	4 200
PWM speed input characteristics		
Input impedance (kΩ)	19	-
Level 0 input voltage (V)	< 2.5	-
Level 1 input voltage (V)	> 11.5	-
Frequency range (Hz)	150 → 1000	-
Full scale speed (rpm)	4 200	-
Output characteristics		
Type of output	PNP	PNP
Max. current (mA)	50	50
Weight (g)	1 400	1 400

Product adaptations

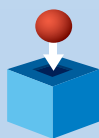

- 2 quadrant speed regulation,
- Motors with hall effect sensors only,
- Adaptations on electronics,
- Special cable lengths,
- Special connectors fitted to the cable.

To order, see page 13

Curves

Speed/torque

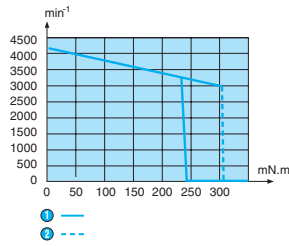

- 1 Continuous operation
- 2 Cyclic operation

Current/torque

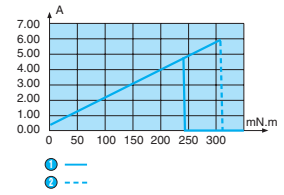

- 1 Continuous operation
- 2 Cyclic operation

Dimensions

Short version 80 180 0

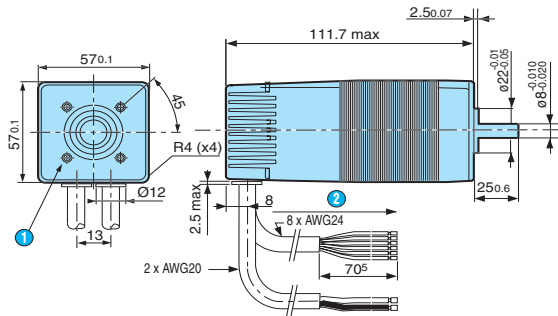

- 1 4 holes M5 x 0.86 H on Ø 40 depth 4.5 mm mini
- 2 Cable length : 500 ± 15 mm

Connections

Marking on motor	Function	Wire colour	
*a	Power earth	Black (2nd harness)	1 power cable AWG20
*a	24 V power supply	Brown (2nd harness)	2 conductors UL2464
	Signal earth	Black	
	On/off input	Green	
	Direction input	Yellow	
	Speed setpoint	Orange	1 control cable AWG24
			8 conductors UL2464
*b	12 points/rev encoder output	Brown	
*b	Encoder direction output	Red	
	Torque limiting setpoint	Blue	
*b	Torque saturation output	Purple	

Applications

Examples of encoder output, direction, torque limit cabling (brown - red - violet)

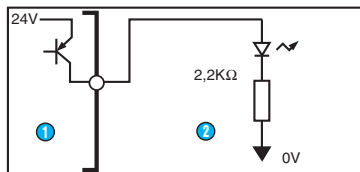

- 1 Motor
- 2 LED load

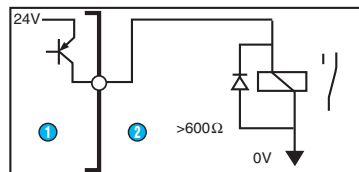

- 1 Motor
- 2 Relay load

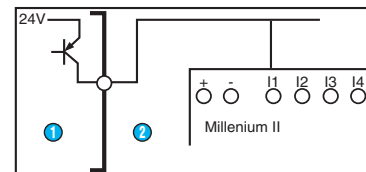

- 1 Motor
- 2 Millenium II+

User information

- *a) Do not invert the polarities
- *b) Do not short-circuit the encoder output (PNP)
- Do not use the motor as a generator

BRUSHLESS DC geared motors

→ 30 Watts with right-angle gearbox

- Output perpendicular to motor,
- Ideal for low reduction ratios,
- Ideal for applications needing a compact motor,
- Silent operation,
- Irreversible with high ratios.



Specifications

Ratios (i)	Output speed (rpm)	Available torque (N.m)	1 stage
5	440	0,6	80 141 001
10	220	1,0	80 141 002
20	110	1,7	80 141 003
30	74	2,1	80 141 004
50	44	2,0	80 141 006

General characteristics	
Motor	80 140
Speed control	0-10 V and PWM
Axial load dynamic (N)	100
Radial load dynamic (N)	150
Temperature rise at 50 % cycle (°C)	45
Weight (g)	1 480

Product adaptations

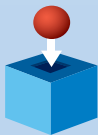

- 2 quadrant speed regulation,
- Motors with hall effect sensors only,
- Adaptations on electronics,
- Special cable lengths,
- Special connectors fitted to the cable.

Dimensions

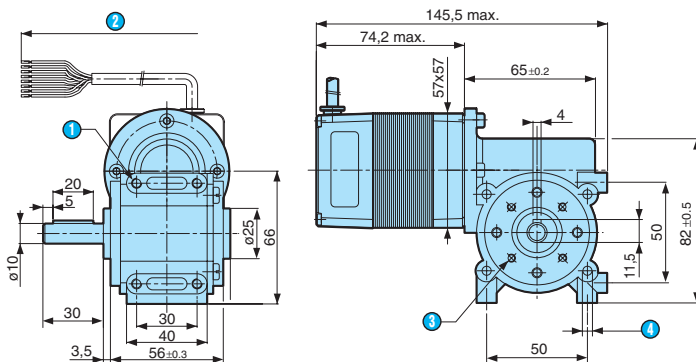

- 1 4 x M5 depth 8 mm
- 2 Cable length 400 ± 10 mm
- 3 4 x M4 on Ø 36 depth 8 mm
- 4 4 x M5 depth 8 mm

User information

Respect the limits and precautions of use written in the 30 W motor section.
 Continuous operation may cause overheating of the gearbox.
 This gearbox is recommended for applications where the on time does not exceed 50 % of the time, please consult us.

BRUSHLESS DC geared motors

→ 30 Watts with Ø 62 planetary gearbox

- Concentric output shaft,
- Ideal for high reduction ratios,
- Ideal for high torque applications,
- High efficiency,
- Reversible.



Specifications

Ratios (i)	Output speed (rpm)	Available torque (N.m)	1 stage	2 stages	3 stages
7	316	0,8	80 149 604		
46	48	5		80 149 605	
308	7	30			80 149 606
General characteristics					
Motor			80 140	80 140	80 140
Speed control			0-10 V and PWM	0-10 V and PWM	0-10 V and PWM
Axial load dynamic (N)			50	70	120
Radial load dynamic (N)			240	360	520
Efficiency (%)			90	80	70
Casing temperature rise at 25°C			35	35	35
Weight (g)			1 600	2 000	2 400

Product adaptations

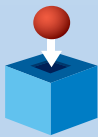

- 2 quadrant speed regulation,
- Motors with hall effect sensors only,
- Adaptations on electronics,
- Special cable lengths,
- Special connectors fitted to the cable.

Dimensions

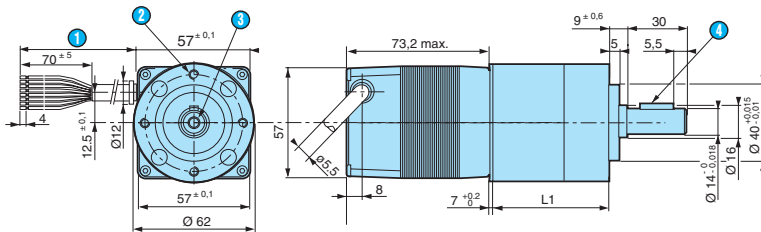

- 1 Cable length 400 ± 10 mm
- 2 4 holes M5 depth 10 at 90° on $\text{Ø}52$
- 3 Fixation hole M5 depth 12.5
- 4 Key A5 x 5 x 18

L1 1 stage : 43.7 mm max.
 L1 2 stages : 59.7 mm max.
 L1 3 stages : 75.2 mm max.

User information

Respect the limits and precautions of use written in the 30W brushless motor section

BRUSHLESS DC geared motors

→ 80 Watts with right-angle gearbox

- Output perpendicular to motor,
- Ideal for low reduction ratios,
- Ideal for applications needing a compact motor,
- Silent operation,
- Irreversible with high ratios.



Specifications

Ratios (i)	Output speed (rpm)	Available torque (N.m)	80 Watts PWM control	80 Watts 0-10 V control
5	650	1,0	80 181 001	80 181 010
10	325	1,7	80 181 002	80 181 011
20	163	2,9	80 181 003	80 181 012
30	108	3,5	80 181 004	80 181 013
50	65	3,4	80 181 006	80 181 015
General characteristics			80 180	80 180
Motor			PWM	0-10 V
Speed control			10	100
Axial load dynamic (daN)			15	150
Radial load dynamic (daN)			45	45
Temperature rise at 50 % cycle (°C)			1 920	1 920
Weight (g)				

Product adaptations

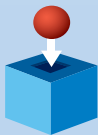

- 2 quadrant speed regulation,
- Motors with hall effect sensors only,
- Adaptations on electronics,
- Special cable lengths,
- Special connectors fitted to the cable.

Dimensions

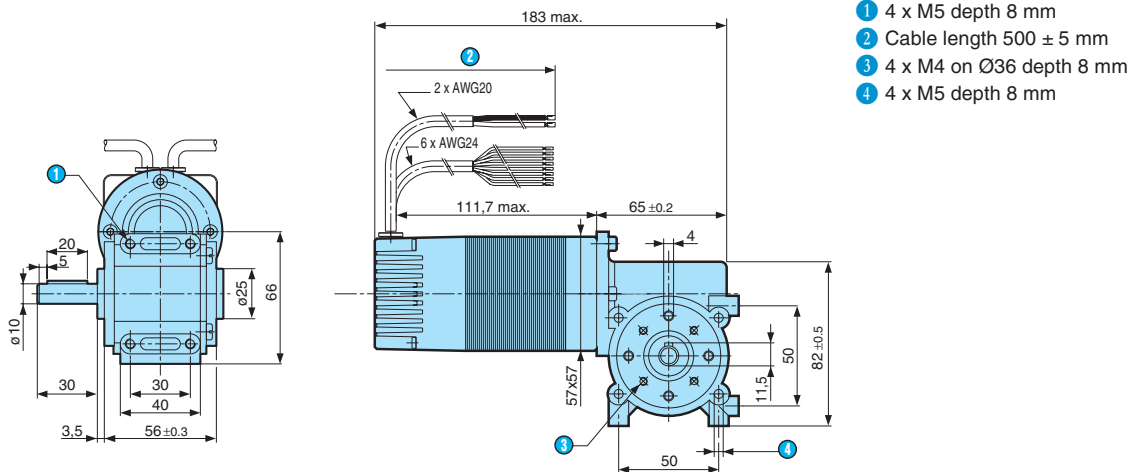

User information

Respect the limits and precautions of use written in the 80 W motor section.
 Continuous operation may cause overheating of the gearbox.
 This gearbox is recommended for applications where the on time does not exceed 50 % of the time, please consult us.

To order, see page 13

BRUSHLESS DC geared motors

→ 80 Watts with Ø 81 planetary gearboxes - PWM control

- Concentric output shaft
- Ideal for high reduction ratios
- Ideal for high torque applications
- High efficiency
- Reversible



Specifications

Ratios (i)	Output speed (rpm)	Available torque (N.m)	1 stage	2 stages	3 stages
5	650	1	80 189 701		
27	120	4,5		80 189 702	
139	23	20			80 189 703
General characteristics			1 stage	2 stages	3 stages
Motor			80 180	80 180	80 180
Speed control			PWM	PWM	PWM
Axial load dynamic (N)			80	120	200
Radial load dynamic (N)			200	300	500
Efficiency (%)			80	70	60
Casing temperature rise at 25°C			35	35	35
Weight (g)			3 200	3 900	4 600

Product adaptations

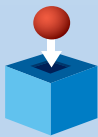

- 2 quadrant speed regulation,
- Motors with hall effect sensors only,
- Adaptations on electronics,
- Special cable lengths,
- Special connectors fitted to the cable.

Dimensions

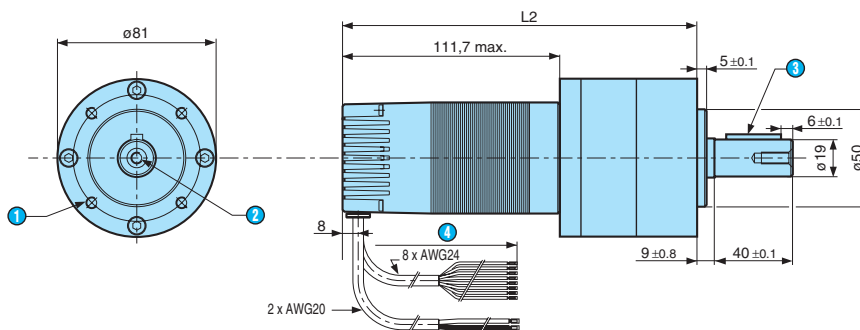

- 1 4 holes M6 x 12 on Ø65
- 2 Fixing hole M6 x 16
- 3 Cable length 500 ± 15 mm
- 4 Key A6 x 6 x 28 according to DIN6885

L2 1 stage : 182 mm max.
 L2 2 stages : 203.9 mm max.
 L2 3 stages : 226 mm max.

User information

Respect the limits and precautions of use written in the 80W brushless motor section.

BRUSHLESS DC geared motors

→ 80 Watts with Ø 81 planetary gearbox - 0-10 V control

- Concentric output shaft,
- Ideal for high reduction ratios,
- Ideal for high torque applications,
- High efficiency,
- Reversible.



Specifications

Ratios (i)	Output speed (rpm)	Available torque (N.m)	1 stage	2 stages	3 stages
5	650	1	80 189 704		
27	120	4,5		80 189 705	
139	23	20			80 189 706
General characteristics					
Motor			80 180	80 180	80 180
Speed control			0-10 V	0-10 V	0-10 V
Axial load dynamic (N)			80	120	200
Radial load dynamic (N)			200	300	500
Efficiency (%)			80	70	60
Casing temperature rise at 25°C			35	35	35
Weight (g)			3 200	3 900	4 600

Product adaptations

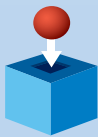

- 2 quadrant speed regulation,
- Motors with hall effect sensors only,
- Adaptations on electronics,
- Special cable lengths,
- Special connectors fitted to the cable.

Dimensions

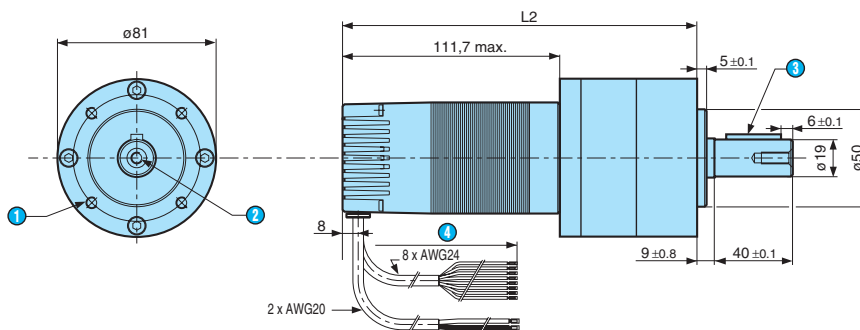

- 1 4 holes M6 x 12 x onØ65
- 2 Fixing hole M6 x 16
- 3 Cable length 500 ± 15 mm
- 4 Key A6 x 6 x 28 according to DIN6885

L2 1 stage : 182 mm max.
 L2 2 stages : 203.9 mm max.
 L2 3 stages : 226 mm max.

User information

Respect the limits and precautions of use written in the 80W brushless motor section.

To order, see page 13

Motomate

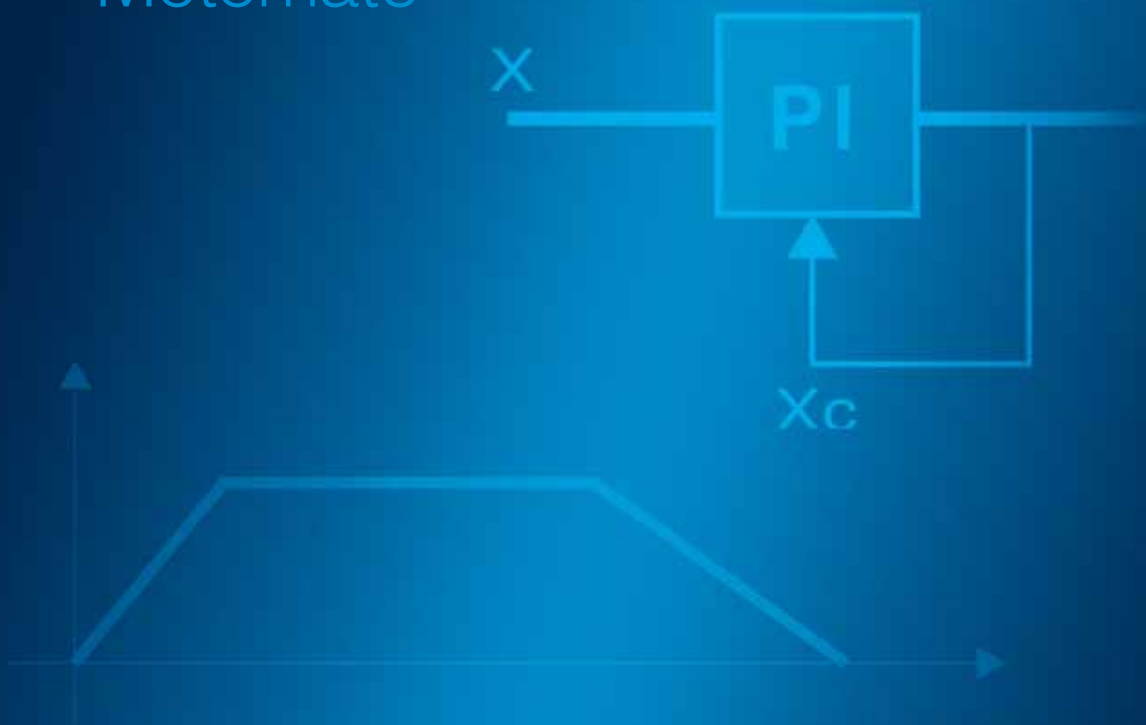

Guide to selecting motomate brushless with controller

Right angle gearbox

Gearbox	Max. torque (Nm)			1	1.7	2.9
	Motors direct drive (Nm)					
Usable Power (W)	Nominal torque (Nm)	Nominal speed (rpm)	Supply voltage (V)	Motor type dimensions (mm)		
80	240	3250	24	▶ p.88 80 080 57x57	▶ p.88 80 081 650 rpm	▶ p.88 80 081 325 rpm
					▶ p.88 80 081 163 rpm	

Planetary gearbox

Gearbox	Max. torque (Nm)			1	4.5	20
	Motors direct drive (Nm)					
Usable Power (W)	Nominal torque (Nm)	Nominal speed (rpm)	Supply voltage (V)	Motor type dimensions (mm)		
30	240	3250	24	▶ p.88 80 080 57x57	▶ p.88 80 089 650 rpm	▶ p.88 80 089 120 rpm
					▶ p.88 80 089 23 rpm	

Choice of gearbox according to mechanical criteria

Right angle	Perpendicular output Silence (<53 dB) Non-reversible from R = 30	Planetary	Output in shaft Increased efficiency Reversible
--------------------	--	------------------	---

Selection of a geared motor

A geared motor is selected according to the required usable power output.

$$\text{Usable Power} = \frac{2\pi}{60} C \cdot n$$

(W) (Nm) (rpm)

A geared motor must have usable power equal to or greater than the power required to rotate the load. It is selected by checking that the point corresponding to the required operating conditions (torque and speed output) is higher than the nominal torque versus speed curve of the geared motor. The required torque output of a geared motor must be within its maximum recommended torque for continuous duty.

3.4

3.5

p.88	80 081	p.88	80 081
			
65 rpm	108 rpm		

3

Motomate - Brushless motor with integrated logic controller

→ Motomate 80 watts

- Movement control for simple mechanisms
- All-in-one solution for quick integration
- Compact with high performance
- Intuitive programming with graphical function blocks
- Adapted for severe environments



Specifications

Type	Ratio	Max. speed (RPM)	Available torque (N.m)	Code
Motor direct drive	-	3 250	0.2	80 080 005
Right angle gearbox	5	650	1	80 081 001
	10	325	1.7	80 081 002
	20	163	2.9	80 081 003
	30	108	3.5	80 081 004
	50	65	3.4	80 081 006
Planetary gearboxes	5	650	1	80 089 704
	27	120	4.5	80 089 705
	139	23	20	80 089 706

Accessories

Designation Code	Designation Code
Programming cable PC/Motomate - serial port	79 294 791
Programming cable PC/Motomate - USB	79 294 790
Programming software on CD ROM	79 294 792

General characteristics

General characteristics	
Supply voltage (V)	24 (20 → 37)
Max. current (A)	6
Immunity from micro power cuts (ms)	1
Operating temperature (°C)	-20 → +40
Protection index	IP 54
Programming	
Inputs / outputs	4I/4O
Programming method	Function blocks / SFC
Program size	128
Program memory	Flash EEPROM
Program cycle time (ms)	10
Real-time clock	No
Logic inputs	
Max. number	4 (I1 → I4)
Input impedance (kΩ)	> 10
Logic 1 voltage threshold (V)	> 15
Logic 0 voltage threshold (V)	< 5
Response time (ms)	10
High speed inputs	
Max. number	2 (I1 → I2)
Max. frequency (KHz)	4
Analogue input	
Max. number	2 (I3 → I4)
Measurement range	0-10 VDC
Resolution	8 bits
Accuracy	± 5 %
Logic outputs / PWM	
Max. number	4 (O1 → O4)
Type of output	PNP
Insulation	No
Max. current (mA)	250
Leakage current (mA)	< 0.1
Response time (ms)	10
PWM frequency (KHz)	0.11 → 1.8
PWM precision at 120 Hz	5 %

To order, see page 13

Dimensions

Direct drive

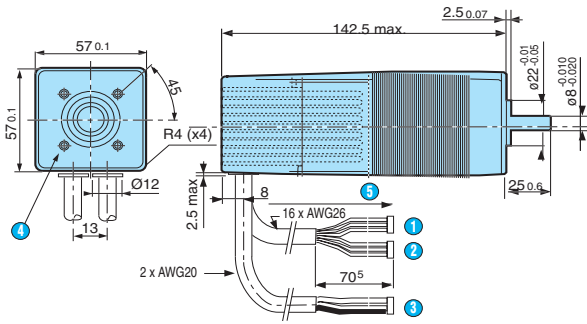

- 1 Connector 6 way Programming motomate
- 2 Connector 10 way Inputs/outputs motomate
- 3 Connector 2 way Power supply
- 4 4 holes M5 at 90° on Ø 40 depth 4.5 mini
- 5 Cable length : 500 ± 15 mm

Right angle gearbox

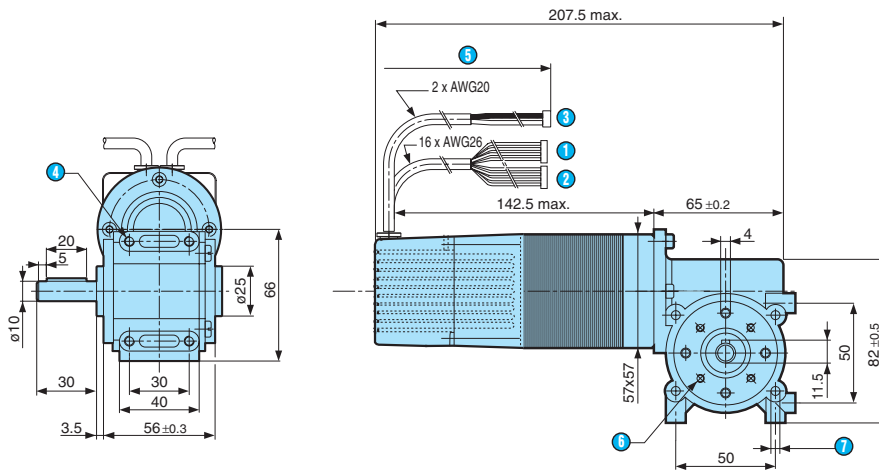

- 1 Connector 6 way Programming motomate
- 2 Connector 10 way Inputs/outputs motomate
- 3 Connector 2 way Power supply
- 4 4 x M5 depth 8 mm
- 5 Cable length 500 ± 5 mm
- 6 4 x M4 on Ø 36 depth 8 mm
- 7 4 x M5 depth 8 mm

Radial load max. = 150 N
Axial load max. = 100 N

Planetary gearboxes

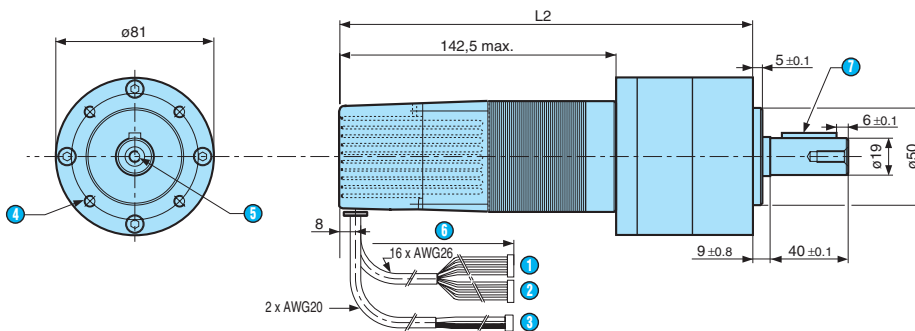

- 1 Connector 6 way Programming motomate
- 2 Connector 10 way Inputs/outputs motomate
- 3 Connector 2 way Power supply
- 4 4 holes M6 on Ø 65 depth 12 mm
- 5 Fixing hole M6 x 16
- 6 Cable length : 500 ± 15 mm
- 7 Key A6 x 6 x 28 according to DIN 6885

L2 Ratio 5 : 212.8 mm max.



L2 Ratio 27 : 234.7 mm max.

L2 Ratio 139 : 256.8 mm max.

Radial load max. = 200/300/500 N

Axial load max. = 80/120/200 N
(according to no. of stages)

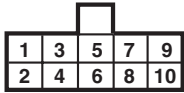
Connections

Comment	Legend	Pin N°	Wire color	Motomate connector	Application connector
*a	+24V	1	Brown	1 power connector Molex 2-way (Ref. 51144-0200)	PCB side top view  Ref. 53520-0220
*a	GND	2	Black		
*b	IN1	1	Brown	1 I/O connector Molex 10-way 2.54 mm spacing (Ref. 90142-0010)	PCB side top view  Ref. 90130-1110
*b	OUT1	2	Blue		
	IN2	3	Orange		
*b	OUT2	4	Purple		
	IN3	5	Yellow		
*b	OUT3	6	Grey		
	IN4	7	Green		
*b	OUT4	8	White		
*a	GND	9	Black	1 programming connector Molex 6-way 2.54 mm spacing (Ref. 90142-0006)	PCB side top view  Ref. 90130-1106
*a	+24V	10	Red		
*a	+5V	1	White-Red		
*a	GND	2	White-Black		
	SCL	3	White-Yellow		
	SDA	4	White-Green		
	RX	5	White-Brown		
	TX	6	White-Orange		

Applications

Examples of input connections

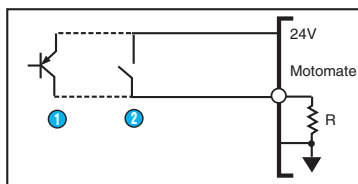

- 1 Sensor output PNP
or
2 Contact

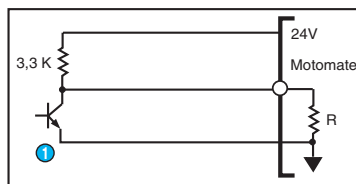

- 1 Sensor output NPN

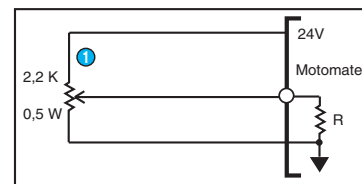

- 1 Potentiometer

Example of output connections

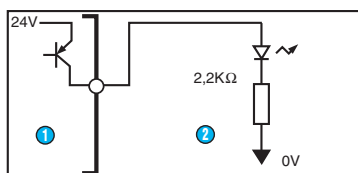

- 1 Motor
2 Load LED

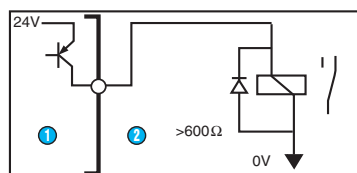

- 1 Motor
2 Load relay

Product adaptations

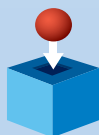

- Special output shaft
- Special supply voltage
- Special cable length
- Customised electronics
- Special connectors
- Special gear ratios
- Special pinion materials
- Special mounting plate

User information

- *a) Never reverse the polarity of the supply
*b) Do not short-circuit the outputs O1 to O4 to earth
- Do not use the motor as a generator
- For more details on the geared motors, consult the brushless catalogue

Motomate The range is extensive

• An all-in-one solution
 • The dedicated solution
 • Total software features
 • The range is extensive
 • Your expertise

CATALOG

Number of axes	Type of product	Resolution	Speed	Max. speed	Max. torque	Max. current
1	1-axis	1000 ppr	1000 rpm	1.50 Nm	1.50 A	1.50 A
2	2-axis	1000 ppr	1000 rpm	1.50 Nm	1.50 A	1.50 A
3	3-axis	1000 ppr	1000 rpm	1.50 Nm	1.50 A	1.50 A
4	4-axis	1000 ppr	1000 rpm	1.50 Nm	1.50 A	1.50 A
5	5-axis	1000 ppr	1000 rpm	1.50 Nm	1.50 A	1.50 A
6	6-axis	1000 ppr	1000 rpm	1.50 Nm	1.50 A	1.50 A
7	7-axis	1000 ppr	1000 rpm	1.50 Nm	1.50 A	1.50 A
8	8-axis	1000 ppr	1000 rpm	1.50 Nm	1.50 A	1.50 A
9	9-axis	1000 ppr	1000 rpm	1.50 Nm	1.50 A	1.50 A
10	10-axis	1000 ppr	1000 rpm	1.50 Nm	1.50 A	1.50 A

3

Motomate An all-in-one solution

• An all-in-one solution
 • The dedicated solution
 • Total software features
 • The range is extensive
 • Your expertise

CATALOG

By integrating Motomate into your equipment you can benefit from all the advantages of an all-in-one function dedicated to programmable motion control. Motomate is a compact product combining Crouzet's expertise in automation and motorization.

Results:

- Lower integration costs of design, assembly and installation stages.
- Quick and easy debugging.
- Industrially optimized control and motorization functions guaranteed by Crouzet.
- Long-term reduction in maintenance costs.

Ready-to-use brushless motor with integrated controller

- 1. 5th. Motor:** The motor's electronic interface both inside and outside the motor.
- 2. Logic controller:** A full PLC complete with 4 inputs and 4 outputs and pre-programmed functions to simplify and reduce debugging operations. Analogue and digital inputs are also available.
- 3. Variable speed drive:** A compact unit integrated in the motor control electronics, with functions optimized by design in comparison to more traditional solutions: variable speed, torque limiting, brake, resistance to locking, etc.
- 4. Encoder:** 2-channel, provides all necessary information regarding motor position and direction of rotation.

Brushless motor: DC motor, zero-commutated, contactless, high torque, silent operation, service life 3 times longer than a conventional DC motor, exceedingly compact in relation to an asynchronous motor.

Encoder: Planetary or right angle. It covers all types of movement.

Synchronous motors

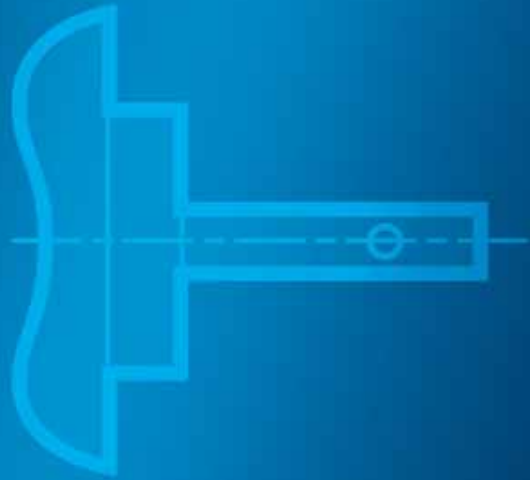

Guide to selecting synchronous motors







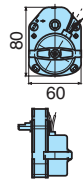
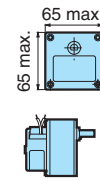

Gearbox		Max. torque (Nm)		0.5		2	
		Type of gearbox		81 021		81 033	
Motors direct drive (Nm)							
Usable Power (W)	Nominal torque (Nm)	Nominal speed (rpm)	Supply voltage (V)	Motor type dimensions (mm)			
Single direction							
0.16	2.5	600	230	▶ p.100 82 340 Ø 47	▶ p.112 82 344 0.001 ... 60 rpm	▶ p.114 82 304 0.003... 32 rpm	
0.42	8	600	230	▶ p.101 82 330 Ø 47	▶ p.110 82 334 0.001 ... 60 rpm	▶ p.114 82 305 0.003... 32 rpm	
Reversible: 2 directions							
0.31	12	250	230	▶ p.102 82 510 Ø 36/50	▶ p.120 82 514 0.5... 50 rpm	▶ p.124 82 519 0.16... 20 rpm	
0.52	10	500					
0.98	37.5	250	230	▶ p.104 82 520 Ø 51/75	▶ p.122 82 524 0.8... 60 rpm	▶ p.126 82 529 0.33... 15 rpm	
1.12	30	375					
1.37	55	250	230	▶ p.106 82 530 Ø 58/79			
2.65	106	250	230	▶ p.108 82 540 65x65			

Selection of a geared motor

A geared motor is selected according to the required usable power output.

$$\text{UsablePower (W)} = \frac{2\pi}{60} C \cdot n \text{ (Nm) (rpm)}$$

A geared motor must have usable power equal to or greater than the power required to rotate the load. It is selected by checking that the point corresponding to the required operating conditions (torque and speed output) is higher than the nominal torque versus speed curve of the geared motor. The required torque output of a geared motor must be within its maximum recommended torque for continuous duty.

3		5	
81 023		81 037	
			
▶p.116 80 333		▶p.118 80 337	
			
0.167... 29 rpm		0.24... 24 rpm	
▶p.128 80 513		▶p.132 80 517	
			
0.069... 24 rpm		0.1... 20 rpm	
▶p.130 80 523		▶p.132/134 80 527	
			
0.069... 12 rpm		0.1... 30 rpm	
▶p.130 80 533			
			
0.069... 12 rpm		▶p.134 80 547	
			
		0.1... 20 rpm	

Some principles of synchronous motors

Why choose a synchronous motor ?

To produce a certain number of movements within a well defined time period - in this case, the motor is used as a time base.

To produce a rotation movement requiring relatively low torque at reasonable cost.

How to select from the Crouzet range

The Crouzet synchronous range consists of the following motor types :

→ 1 Single direction

Either :

- clockwise (CW or SA)
- or anti-clockwise (ACL or SI)

(We will see below how to ensure the correct direction of rotation). In special applications it is possible to dispense with the anti-return totally (SAR version). In this case, the motor may rotate in a clockwise direction.

→ 2 Reversible

The motor rotates in either a clockwise or an anti-clockwise direction. The direction of rotation is controlled by a capacitor.

Definition of a synchronous motor

This motor is characterised by a constant speed of rotation which is independent of the load but linked to the supply frequency.

A synchronous motor maintains its speed of rotation until an overload occurs.

When overload occurs, the motor loses synchronisation, ie. it stops and develops an oscillation (vibration).

→ Speed of rotation

This basic characteristic can be calculated as below :

$$\text{Speed (in rpm)} = \frac{60 \times f \text{ (en Hz)}}{P}$$

f Hz : The frequency of the AC voltage through the coil.

P : The number of pole pairs in the motor
(1 pair = 1 North Pole + 1 South Pole).

Therefore the speed of rotation of a synchronous motor is defined by its construction.

Example :

A motor equipped with 5 pole pairs would give :

$$V = \frac{60 \times 50}{5} = 600 \text{ rpm using a 50 Hz supply}$$

and

$$V = \frac{60 \times 60}{5} = 720 \text{ rpm using US supply (60 Hz)}$$

→ Construction of a permanent magnet synchronous motor

Single direction

Technology

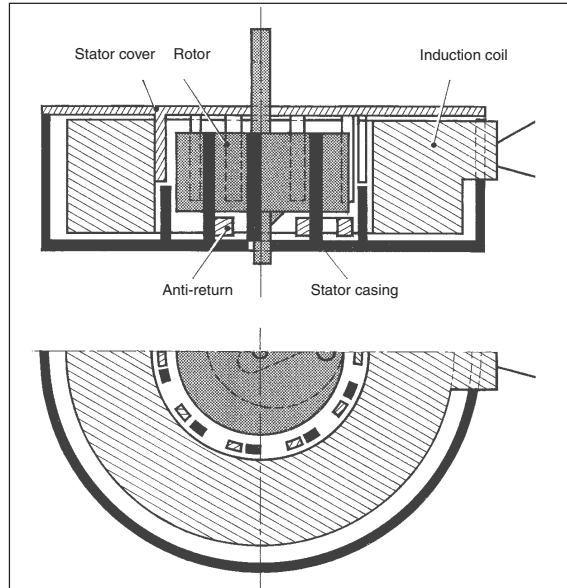

■ Casing poles S.N.S.N.S.N

▨ Cover poles N.S.N.S.N.S

Our single direction motors are only available with a mechanical anti-return. This assembly offers the double advantage of being a relatively simple technical design while offering good performance.

The permanent magnet rotor has at its periphery a number of alternating NORTH and SOUTH poles equal to the number of poles on the stator. The latter, energised by a single coil connected to an AC supply, produces a magnetic asymmetry which positions the rotor when stopped in such a way that it is attracted by an oscillating torque when the current is switched on.

This start-up condition would cause the motor to turn in either direction if a mechanical device called an «anti-return» did not define and impose the direction of rotation.

→ Principle of operation

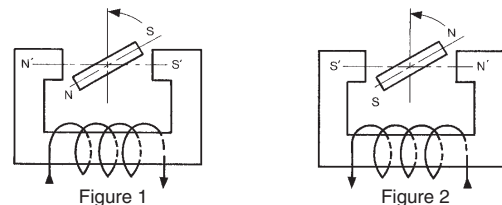

The principle assumes an electro-magnet : a permanent NS magnet rotates around axis O in the air-gap of the electro-magnet, perpendicular to the lines of magnetic force.

Let us suppose that this moving permanent magnet reaches the position marked in figure 1. If the relative positions of the electro-magnet poles are as shown in this figure, the magnet will be repelled and tend to oscillate around an equilibrium position at 180° to direction SN'.

When the permanent magnet is just past this position (figure 2) and the polarity of the electro-magnet is reversed, the magnet will be repelled and return to its previous position, and so on.

By energising the electro-magnet with an AC current of frequency f , the magnet will turn at a speed of f revolutions per second.

In these circumstances, a motor can start up in either direction. To determine a particular direction, a mechanical device (anti-return) is placed on the rotor to ensure that the motor operates only in the direction required. There are several types of anti-return device which are differentiated by the degree of the reverse rotation angle within which the rotor can move.

Reversible
(Also called reversible synchronous motor)

Technology

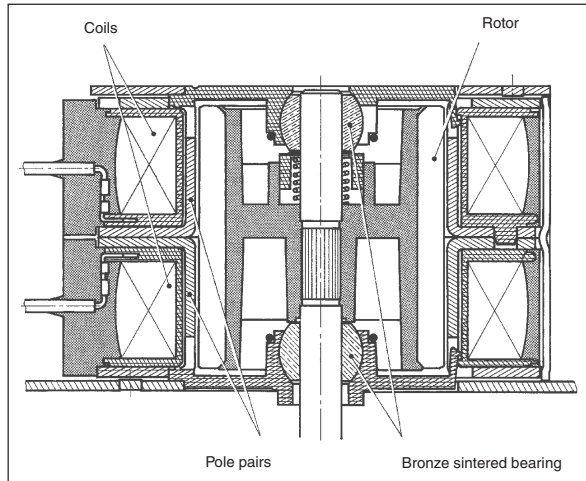

Synchronous motors with a single-phase AC voltage and a permanent magnet must have, for reverse operation, at least 2 stators and 2 coils. Reverse operation can be achieved electrically using a single-pole switch.

A capacitor is used on reversible synchronous motors with 2 coils to produce an electrical dephasing of 90° between the 2 coils. This creates a circular revolving magnetic field. Component precision assures a perfectly circular field and ensures silent motor operation.

→ **Wiring diagram for capacitor**

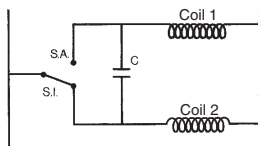

The capacitor specification must be appropriate to each type of motor and to the supply voltage. An incorrect capacitor may distort the magnetic field and have detrimental effects on the reliability of the start-up of the motor as well as on operational quality.

The curve (motor reversing curve) below shows the limits within which the motor will always start in relation to variation in supply voltage and the capacitor values.

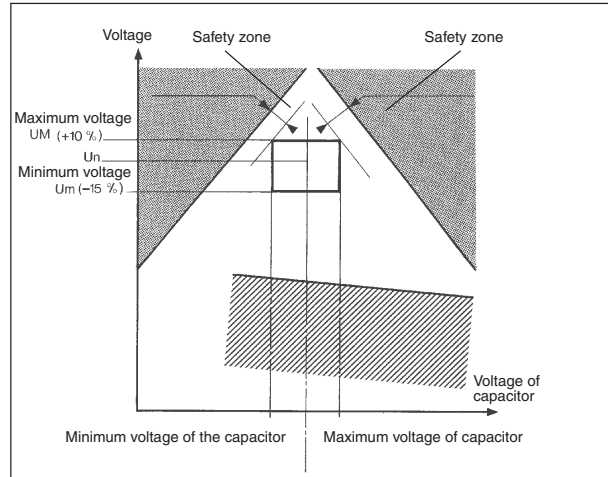

The zone within which the motor operates, i.e. the area around the nominal voltage of the capacitor, must be completely controlled by the manufacturer. Operating within this zone guarantees starting and operating in the direction selected by the user. As the diagram shows, we build our motors so that the operating zone is as far as possible from the critical zones, whatever the nature of the torque.

Boosted winding

Our experience in this area allows us, in certain cases and depending on the precise specification, to operate outside this zone to produce a higher torque and increase performance by between 30 and 80%. Please consult us.

→ **Motor torque**

2 types of torque can be distinguished.

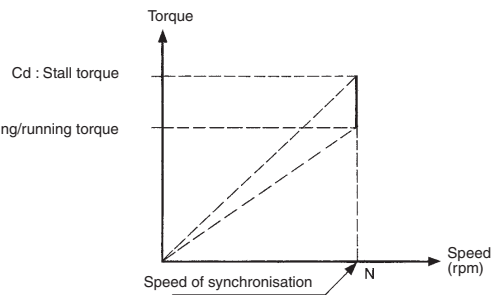

Starting/running torque (or synchronisation torque)
This is the torque that a synchronous motor can develop both at start-up and at synchronisation speed.

N.B:
In all technical data concerning geared motors in this catalogue, the torque/speed curves indicate the value of the starting/running torque for all the gearbox output speeds.

Stall torque (or desynchronisation torque)
This is the torque limit at which a synchronous motor loses its synchronisation.

Motor and gearbox combination

The motor output shaft turns at a defined speed. This speed is generally too high for the majority of applications.

To reduce this speed we provide users with a complete range of gearboxes, each equipped with a series of ratios.

As a result, the motors can be used for numerous functions.

→ Gearbox characteristics

Each gearbox has been designed for a certain workload. We have defined its potential and its limits for optimum mechanical life.

The principal characteristic is its capacity to absorb a maximum torque in continuous operation.

The range of gearboxes in this catalogue can be used for maximum torques of between 0.5 and 6 N.m for long mechanical lives. The values given are for standard products used in the normal operating conditions specified.

In certain cases, these values can be increased if the required life is reduced. Special cases are dealt with by our design staff.

Each gearbox nevertheless has a limit which is the

Breakdown torque

This torque, applied to the gearbox, can cause its destruction when first used.

→ Gearbox construction

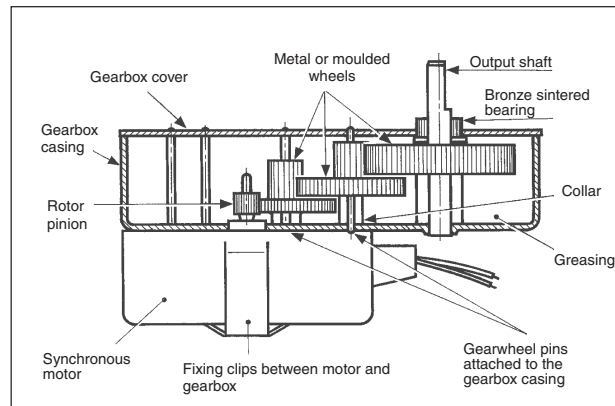

Selecting a geared motor

Selection is made in relation to the prospective workload.

Before making a selection, it should be remembered that the motor absorbs a certain amount of power, the absorbed power and it cannot deliver more than a fraction of this power: the maximum is defined as the usable power or the mechanical power.

Usable power links 2 factors.

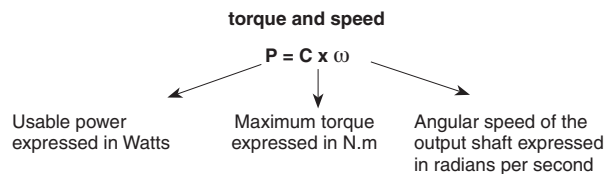

Analysis of this formula clearly shows the function of the gearbox.

It reduces speed and increases torque since the usable power produced by the motor is recovered by the gearbox (within the limits of normal efficiency of course).

The torque requirement thus serves to define the gearbox (characterised by its maximum torque) and the choice of motor depends on the speed at which the torque is required.

The usable power should be borne in mind in all cases, as it is the basic parameter when choosing a motor.

Addinal information

→ Temperature rise

Permanent magnet motors generally have relatively low efficiency and some of the lost energy is converted into a rise in the temperature of the motor.

We consider that this rise in temperature reaches its maximum level after 2 hours of continuous operation.

To calculate the rise, we use the method known as resistance variation.

$$\Delta T = \frac{\Delta R}{R} (234.5 + T_a) - (T_1 - T_a)$$

R = Coil resistance at ambient temperature before applying voltage to the motor (expressed in Ohms - Ω).

R' = Resistance of the same coil after 2 hours of continuous motor operation.s

ΔR = R' - R = Increase in coil resistance.

T1 = Ambient temperature at the end of the test.

Ta = Ambient temperature at the beginning of the test.

→ Dielectric strength

All our products are tested to current standards.

→ Insulation resistance

This is greater than or equal to 75,000 MΩ measured using a 500 VDC current in conditions of ambient temperature and humidity.

→ Safety

Crouzet synchronous motors are designed and manufactured for integration into equipment or machines meeting, for example, the requirements of the Machinery standard : EN 60335-1 (IEC 335-1) : Safety of domestic electrical appliances.

Integration of Crouzet synchronous motors into appliances or machines should, as a rule, take into account the following motor characteristics :

- no earth connection,
- so-called «principal insulation» motors (single insulation)
- protection index : IP40
- insulation class : B.

Standards and approvals

Our motors are in general designed to conform to international recommendations (IEC), American standards (UL - CSA) and/or European standards (EN).

Proof of compliance with these standards and recommendations is demonstrated by an approval (a mark or certificate of conformity granted by an accredited body) or the manufacturer's declaration of conformity (drafted in accordance with ISO/IEC 22 guidelines).

Rules and regulations

→ EC directives

Our motors are compatible with European Community directives (Low voltage 73/23 > 50 VAC) and in particular the aspects of electrical safety referred to in the above standard EN 60335 (domestic electrical appliances).

The «CE» mark on all our products is proof of this conformity.

Moreover, our products are particularly suited, for example, to applications concerning both office equipment and medical equipment covered by standards EN 60601 and EN 60950 respectively.

→ Environmental protection

The modern concept of protection of the environment is an integral part of our motors, from product design through to packaging.

Electromagnetic compatibility

(EC Directive 89/336/EEC dated 03/05/89)

Both asynchronous and synchronous motors and geared motors designed for integration into more complex equipment by professionals, rather than end users, are excluded from the areas of application of this directive.

Crouzet will however be pleased to provide the EMC characteristics of its products on request.

Direct drive single direction synchronous motors

→ Starting/running torque 2.5 mNm

- Constant speed dependent on supply frequency
- Direction of rotation controlled by long-life mechanical anti-return
- Permanent magnet rotor with 5 pole pairs
- Toughened shaft turning on two moulded polyamide bearings
- UL, CSA (class B) - VDE approved.



Specifications

Type	82 340 0
Voltages/Frequencies	230 V 50 Hz
Direction of rotation	
Clockwise	82 340 194
Anti-clockwise	82 340 195
General characteristics	
Base speed of motor (rpm)	600
Absorbed power (W)	3
Usable Power (W)	0.16
Starting/running torque (mN.m)	2.5
Stall torque (mN.m)	3.3
Temperature rise (°C)	55
Ambient temperature (°C)	-5 → +60
Maximum inertial load that can be moved (g.cm ²)	4.6
Number of offload starts 10 ⁶	10
Max. reverse rotation angle (°)	360
Insulation resistance (MΩ)	75 x 10 ³
Breakdown voltage (V-50 Hz)	1800 - 1 s
Weight (g)	110
Wires length mm (approximately)	250
Protection rating	IP30

Product adaptations

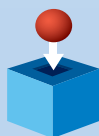

- Pinion on output shaft
- Special supply voltages
- Special cable lengths
- Special connectors

Dimensions

82 340 0

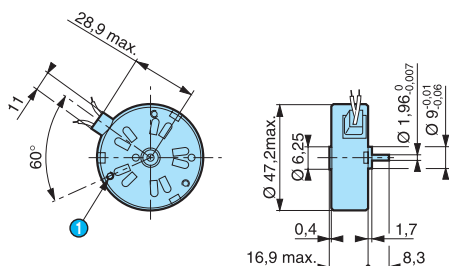

- ① 3 fixing holes ØM2 at 120° on r=19.5 max. depth 2.4 mm

Other information

The speed of a motor powered by a 60 Hz supply is 20 % higher than that of a motor powered by a 50 Hz supply.

To order, see page 13

Direct drive single direction synchronous motors

→ Starting/running torque 8 mNm

- Constant speed dependent on supply frequency
- Direction of rotation controlled by long-life mechanical anti-return
- Permanent magnet rotor with 5 pole pairs
- Toughened shaft turning on two moulded polyamide bearings
- UL, CSA (class B) - VDE approved



Specifications

Type	82 330 5
Voltage / Frequency	230 V - 50 Hz
Direction of rotation	
Clockwise	82 330 582
Anti-clockwise	82 330 583
General characteristics	
Base speed of motor (50 Hz) (rpm)	600
Absorbed power (W)	3.5
Usable Power (W)	0.42
Starting/running torque (mN.m)	8
Stall torque (mN.m)	12
Temperature rise (°C)	55
Ambient temperature (°C)	-5 → +60
Maximum inertial load that can be moved (g.cm ²)	11
Number of offload starts 10 ⁶	10
Max. reverse rotation angle (°)	72
Insulation resistance (MΩ)	75 x 10 ³
Breakdown voltage (V-50 Hz)	1800 - 1 s
Weight (g)	160
Wires length mm (approximately)	250
Protection rating	IP30

Product adaptations

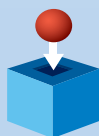

- Pinion on output shaft
- Special supply voltages
- Special cable lengths
- Special connectors

Dimensions

82 330 5

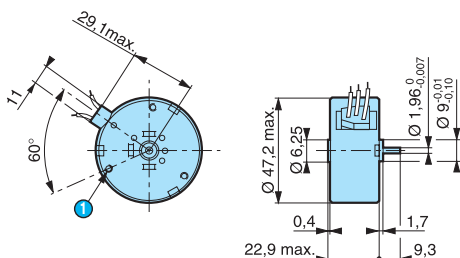

- ① 3 fixing holes Ø M2 at 120 ° on r=19.5 max. depth 3.5 mm

Other information

The speed of a motor powered by a 60 Hz supply is 20 % higher than that of a motor powered by a 50 Hz supply.

To order, see page 13

Direct drive reversible synchronous motors

→ Starting/running torque 12 mNm

- Constant speed, dependant upon supply frequency
- Direction of rotation controlled by dephasing capacitor
- Sintered bearing lubricated for life
- Silent operation
- UL, CSA (class B) - VDE approved.



Specifications

	2.7 Watts	2.7 Watts
Type	82 510 0	82 510 5
Voltages/Frequencies	230 - 240 V 50 Hz	230 - 240 V - 50/60 Hz
Part numbers	82 510 0	82 510 5
General characteristics		
Base speed of motor (rpm)	250	500
Absorbed power (W)	2.7	2.7
Usable Power (W)	0.31	0.52
Starting/running torque (mN.m)	12	10
Stall torque (mN.m)	15	12
Temperature rise (°C)	55	65
Ambient temperature (°C)	-10 +75	-5 +65
Maximum inertial load that can be moved (g.cm ²)	22	22
Number of offload starts	∞	∞
Insulation resistance (MΩ)	75x10 ³	75x10 ³
Breakdown voltage (V-50 Hz)	1800-1 sec	1800-1 sec
Weight (g)	90	90
Wires length mm (approximately)	250	250
Protection rating	IP40	IP40

Product adaptations

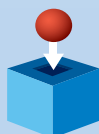

- Special output shafts
- Pinion on output shaft
- Special supply voltages
- Special cable lengths
- Special output bearings
- Special mounting plate
- Special connectors

Accessories

Voltages/Frequencies	μF	V	Code
Capacitors motors 82 510 0/3			
230-240 V - 50 Hz	$0.33 \pm 10 \%$	400	26 231 801
115 V - 50/60 Hz	$0.27 \pm 10 \%$	250	26 231 851
24 V - 50 Hz	$8.2 \pm 10 \%$	70	26 231 711
24 V - 60 Hz	$6.8 \pm 10 \%$	63	26 231 708
Capacitors motor 82 510 5/8			
230-240 V 50/60 Hz	$0.39 \pm 10 \%$	630	26 231 924
115 V - 50/60 Hz	$0.39 \pm 10 \%$	630	26 231 924
24 V - 50/60 Hz	$8.2 \pm 10 \%$	70	26 231 711

Dimensions

82 510 0

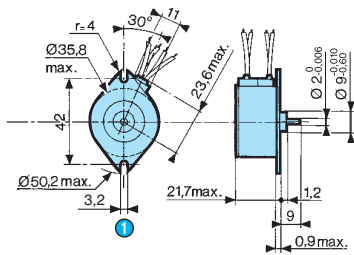

1 2 fixing holes $\text{Ø} 3.2$

82 510 5

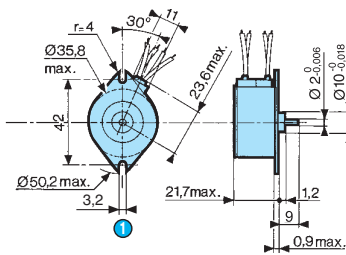

1 2 fixing holes $\text{Ø} 3.2$

Connections

In parallel
Motors 82 510 0

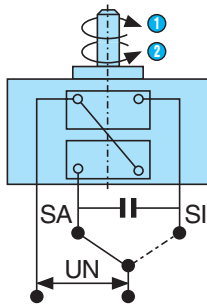

1 SA : Clockwise
2 SI : Anti-clockwise

In series
Motors 82 510 0/5 only
230 V - 240 V 50 Hz version

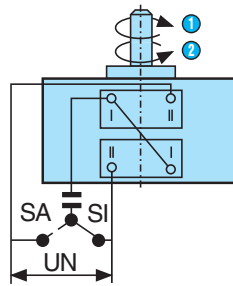

1 SA : Clockwise
2 SI : Anti-clockwise

Other information

The speed of a motor powered by a 60 Hz supply is 20 % higher than that of a motor powered by a 50 Hz supply.

Direct drive reversible synchronous motors

→ Starting/running torque from 30 and 37.5 mN.m

- Constant speed, dependent on supply frequency
- Direction of rotation controlled by dephasing capacitor
- Sintered bearing lubricated for life
- Silent operation
- UL, CSA (classe B) - VDE approved



Specifications

	3.5 Watts	3.5 Watts
Type	82 520 0	82 520 4
Voltages/Frequencies	230-240 V 50 Hz	230-240 V 50 Hz
Part numbers	82 520 014	82 520 4
General characteristics		
Base speed of motor (rpm)	250	375
Absorbed power (W)	3.5	3.5
Usable Power (W)	0.98	1.12
Starting/running torque (mN.m)	37.5	30
Stall torque (mN.m)	42	31
Temperature rise (°C)	55	55
Ambient temperature (°C)	-10+75	-10+75
Maximum inertial load that can be moved (g.cm ²)	33	33
Number of offload starts	∞	∞
Insulation resistance (MΩ)	75x10 ³	75x10 ³
Breakdown voltage (V-50 Hz)	1800 -1 sec.	1800 -1 sec.
Weight (g)	210	210
Wires length mm (approximately)	250	250
Protection rating	IP40	IP40

4

Product adaptations

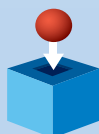

- Special output shafts
- Pinion on output shaft
- Special supply voltages
- Special cable lengths
- Special output bearings
- Special mounting plate
- Special connectors

To order, see page 13

Accessories

Voltages/Frequencies	μF	V	Code
Capacitors motor 82 520 0			
230/240 V - 50 Hz	$0.10 \pm 10 \%$	700	26 231 941
115 V 60 Hz	$0.33 \pm 10 \%$	400	26 231 801
24 V - 50 Hz	$8.2 \pm 10 \%$	70	26 231 711
Capacitors motor 82 520 4			
230/240 V - 50 Hz	$0.12 \pm 10 \%$	600	26 231 903
115 V - 60 Hz	$0.39 \pm 5 \%$	630	26 231 924
24 V - 50 Hz	$15 \pm 5 \%$	70	26 231 728
24 V - 60 Hz	$12 \pm 5 \%$	63	26 231 145

Dimensions

82 520 0

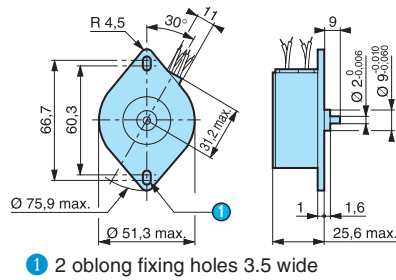

Connections

In parallel

Motors 82 520 0 - 82 520 4

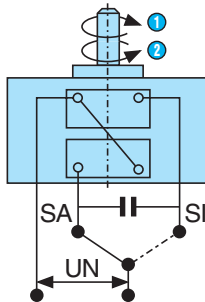

- ① SA : Clockwise
- ② SI : Anti-clockwise

Other information

The speed of a motor powered by a 60 Hz supply is 20 % higher than that of a motor powered by a 50 Hz supply.

Direct drive reversible synchronous motors

→ Starting/running torque 55 mN.m

- Constant speed, dependent on supply frequency
- Direction of rotation controlled by dephasing capacitor
- Sintered bearing lubricated for life
- Silent operation
- UL, CSA (class B) - VDE approved.



Specifications

Type	82 530 0
Voltage / Frequency	230-240 V 50 Hz
Part numbers	82 530 0
General characteristics	
Base speed of motor (rpm)	250
Absorbed power (W)	3.6
Usable Power (W)	1.37
Starting/running torque (mN.m)	55
Stall torque (mN.m)	58
Temperature rise (°C)	45
Ambient temperature (°C)	-10 → +85
Maximum inertial load that can be moved (g.cm ²)	130
Number of offload starts	∞
Insulation resistance (MΩ)	75x10 ³
Breakdown voltage (V-50 Hz)	1800 -1 sec.
Weight (g)	340
Wires length mm (approximately)	250
Protection rating	IP40

Product adaptations

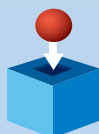

- Special output shafts
- Pinion or bush on output shaft
- Special supply voltages
- Special cable lengths
- Special output bearings
- Special mounting plate
- Special connectors

Accessories

Voltages/Frequencies	μF	V	Code
Capacitors motor 82 530 0			
230-240 V - 50 Hz	$0.10 \pm 10 \%$	700	26 231 941
115 V 50/60 Hz	$0.39 \pm 10 \%$	630	26 231 924
24 V - 50 Hz	$10 \pm 5 \%$	100	26 231 720
24 V - 60 Hz	$6.8 \pm 10 \%$	63	26 231 708

Dimensions

82 530 0

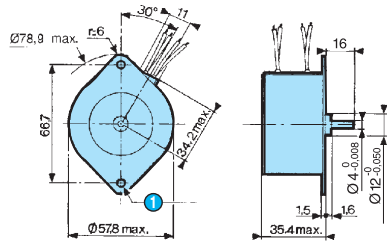

① 2 fixing holes $\text{Ø} 4.4$

Connections

In parallel
Motors 82 530 0

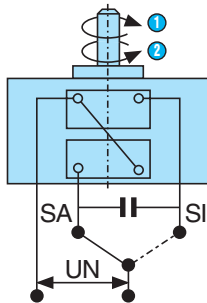

- ① SA : Clockwise
- ② SI : Anti-clockwise

Other information

The speed of a motor powered by a 60 Hz supply is 20 % higher than that of a motor powered by a 50 Hz supply.

Direct drive reversible synchronous motors

→ Starting/running torque 106 mN.m

- Constant speed, dependent on supply frequency
- Direction of rotation controlled by dephasing capacitor
- Sintered bearing lubricated for life
- Silent operation
- UL, CSA (class B) - VDE approved.



Specifications

Type	82 540 0
Voltages/Frequencies	230-240 V 510 Hz
Part numbers	82 540 0
General characteristics	
Base speed of motor (rpm)	250
Absorbed power (W)	7.2
Usable Power (W)	2.65
Starting/running torque (mN.m)	106
Stall torque (mN.m)	118
Temperature rise (°C)	60
Ambient temperature (°C)	-10 +70
Maximum inertial load that can be moved (g.cm ²)	180
Number of offload starts	∞
Insulation resistance (MΩ)	75x10 ³
Breakdown voltage (V-50 Hz)	1800 -1 sec.
Weight (g)	540
Wires length (mm)	250
Protection rating	IP40

Product adaptations

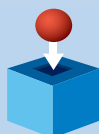

- Special output shafts
- Pinion on output shaft
- Special supply voltages
- Special cable lengths
- Special output bearings
- Special mounting plate
- Special connectors

Accessories

Voltages/Frequencies	μF	V	Code
Capacitors motor 82 540 0			
230-240 V 50 Hz	$0.22 \pm 5 \%$	630	26 231 909
115 V - 60 Hz	$0.56 \pm 5 \%$	400	26 231 822
24 V - 50 Hz	$22 \pm 10 \%$	63	26 231 703
24 V - 60 Hz	$15 \pm 5 \%$	70	26 231 728

Dimensions

82 540 0

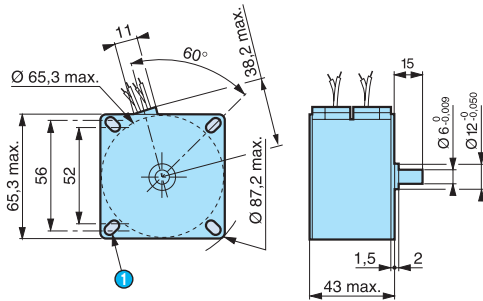

- ① 4 oblong fixing holes 4.2 mm wide

Connections

In parallel
Motors 82 540 0

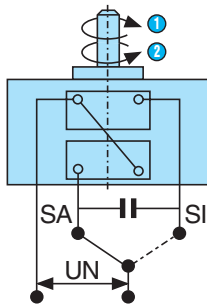

- ① SA : Clockwise
② SI : Anti-clockwise

Other information

The speed of a motor powered by a 60 Hz supply is 20 % higher than that of a motor powered by a 50 Hz supply.

Single direction synchronous geared motors

→ 0.5 Nm 3.5 Watts

- Mechanical strength : 0.5 Nm
- Constant speed, dependent on supply frequency
- Wide range of speeds available
- Direction of rotation controlled by long-life mechanical anti-return device
- Permanent magnet rotor



Specifications

	3.5 Watts	3.5 Watts	3.5 Watts	3.5 Watts
Type	82 334 5	82 334 5	82 334 5	82 334 5
Direction of rotation	Anti-clockwise	Clockwise	Anti-clockwise	Clockwise
Voltages/Frequencies	230 V 50 Hz	230 V 50 Hz	240 V 50 Hz	240 V 50 Hz
Output speed	Ratios (i)			
60 rpm	10	82 334 734	82 334 726	82 334 811
50 rpm	12	●	●	●
30 rpm	20	82 334 728	82 334 736	82 334 805
20 rpm	30	82 334 730	82 334 738	82 334 807
15 rpm	40	82 334 731	82 334 739	82 334 808
12.5 rpm	48	●	●	●
12 rpm	50	82 334 733	82 334 741	82 334 810
10 rpm	60	82 334 756	82 334 764	82 334 772
7.5 rpm	80	82 334 758	82 334 766	82 334 774
6 rpm	100	82 334 759	82 334 767	82 334 775
5 rpm	120	82 334 760	82 334 768	82 334 776
4 rpm	150	82 334 769	82 334 761	82 334 785
3 rpm	200	●	●	●
2.5 rpm	240	●	●	●
2 rpm	300	82 334 748	82 334 742	82 334 796
1 rpm	600	82 334 744	82 334 751	82 334 792
0.80 rpm	750	●	●	●
0.5 rpm	1200	●	●	●
0.33 rpm	1800	●	●	82 334 794
0.25 rpm	2400	●	●	●
0.20 rpm	3000	●	●	●
0.10 rpm	6000	●	●	●
5.00 rph	7200	●	●	●
4.00 rph	9000	●	●	●
3.00 rph	12000	●	●	●
2.50 rph	14400	●	●	●
1.00 rph	36000	●	●	●
0.50 rph	72000	●	●	●
1/12 rph	432000	●	●	●
1/24 rph	864000	●	●	●
General characteristics				
Motor	82 340 0	82 340 0	82 340 0	82 340 0
Gearbox	81 021 0	81 021 0	81 021 0	81 021 0
Maximum permitted torque from gearmotor under continuous conditions for 1 millions turns of the gearmotor (Nm)	0.5	0.5	0.5	0.5
Axial load static (daN)	1	1	1	1
Radial load static (daN)	8	8	8	8
Absorbed power (W)	3	3	3	3
Motor output (W)	0.16	0.16	0.16	0.16
Maximum temperature rise (°C)	55	55	55	55
Ambient temperature (°C)	-5 → +60	-5 → +60	-5 → +60	-5 → +60
Weight (g)	160	160	160	160
Wires length mm (approximately)	250	250	250	250
Protection rating	IP40	IP40	IP40	IP40

Product adaptations

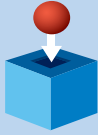

- Special supply voltages
- Special cable lengths
- Special connectors
- Special output shafts
- Special gearbox ratios
- Special gear wheel material
- Special output bearings

Curves

Graph of torque versus speed 82 334 5

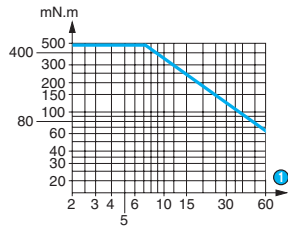

① RPM

Dimensions

82 334 5

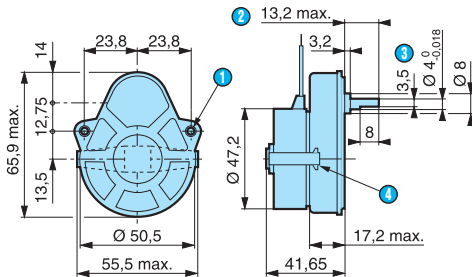

- ① 2 fixing holes Ø 3.2
- ② (pushed-in shaft)
- ③ 3.5 across flat
- ④ Fixing clip

Options

Shaft 79 200 967

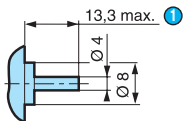

- ① (pushed-in shaft ←)

Shaft 79 200 779

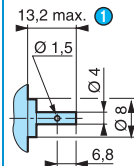

- ① (pushed-in shaft ←)

Shaft 70 999 421 SP1295-10

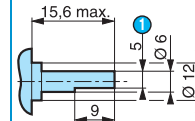

- ① Across flat

Other information

The speed of a motor powered by a 60 Hz supply is 20 % higher than that of a motor powered by a 50 Hz supply.

Single direction synchronous geared motors

→ 0.5 Nm 3 Watts

- Mechanical strength : 0.5 Nm
- Constant speed, dependent on supply frequency
- Wide range of speeds available
- Direction of rotation controlled by long-life mechanical anti-return device
- Permanent magnet rotor



Specifications

	3 Watts	3 Watts	3 Watts	3 Watts
Type	82 344 0	82 344 0	82 344 0	82 344 0
Direction of rotation	Anti-clockwise	Anti-clockwise	Clockwise	Clockwise
Voltages/Frequencies	230 V 50 Hz	240 V 50 Hz	230 V 50 Hz	240 V 50 Hz
Output speed	Ratios (i)			
60 rpm	10	82 344 744	82 344 736	82 344 698
50 rpm	12	●	●	●
50 rpm	20	82 344 738	82 344 746	82 344 692
20 rpm	30	82 344 740	82 344 748	82 344 694
15 rpm	40	82 344 741	82 344 749	82 344 695
12.5 rpm	48	●	●	●
12 rpm	50	82 344 743	82 344 751	82 344 697
10 rpm	60	82 344 752	82 344 760	82 344 706
7.5 rpm	80	82 344 754	82 344 762	82 344 708
6 rpm	100	82 344 755	82 344 763	82 344 709
5 rpm	120	82 344 756	82 344 764	82 344 710
4 rpm	150	82 344 765	82 344 767	82 344 719
3 rpm	200	82 344 766	82 344 768	82 344 720
2.5 rpm	240	●	●	●
2 rpm	300	82 344 775	82 344 768	82 344 729
1 rpm	600	82 344 771	82 344 778	82 344 725
0.80 rpm	750	●	●	●
0.5 rpm	1200	82 344 772	82 344 779	82 344 726
0.33 rpm	1800	82 344 773	82 344 780	82 344 727
0.25 rpm	2400	●	●	●
0.20 rpm	3000	●	●	●
0.10 rpm	6000	●	●	●
5.00 rph	7200	●	●	●
4.00 rph	9000	●	●	●
3.00 rph	12000	●	●	●
2.50 rph	14400	●	●	●
1.00 rph	36000	●	●	●
0.50 rph	72000	●	●	●
1/12 rph	432000	●	●	●
1/24 rph	864000	●	●	●
General characteristics				
Motor	82 340 0	82 340 0	82 340 0	82 340 0
Gearbox	81 021 0	81 021 0	81 021 0	81 021 0
Maximum permitted torque from gearmotor under continuous conditions for 1 millions turns of the gearmotor (Nm)	0.5	0.5	0.5	0.5
Axial load static (daN)	1	1	1	1
Radial load static (daN)	8	8	8	8
Absorbed power (W)	3	3	3	3
Motor output (W)	0.16	0.16	0.16	0.16
Maximum temperature rise (°C)	55	55	55	55
Ambient temperature (°C)	-5 → +60	-5 → +60	-5 → +60	-5 → +60
Weight (g)	160	160	160	160
Wires length mm (approximately)	250	250	250	250
Protection rating	IP40	IP40	IP40	IP40

To order, see page 13

Product adaptations

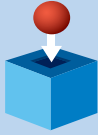

- Special supply voltages
- Special cable lengths
- Special connectors
- Special output shafts
- Special gearbox ratios
- Special gear wheel material
- Special output bearings

Curves

Graph of torque versus speed 82 344 0

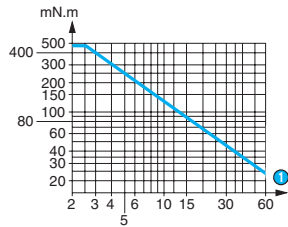

① RPM

Dimensions

82 344 0

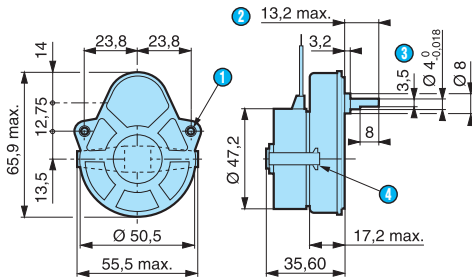

- ① 2 fixing holes Ø 3.2
- ② (pushed-in shaft)
- ③ 3.5 across flat
- ④ Fixing clip

Options

Shaft 79 200 967

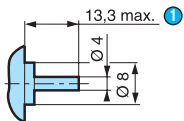

- ① (pushed-in shaft ←)

Shaft 79 200 779

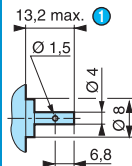

- ① (pushed-in shaft ←)

Shaft 70 999 421 SP1295-10

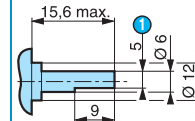

- ① Across flat

Other information

The speed of a motor powered by a 60 Hz supply is 20 % higher than that of a motor powered by a 50 Hz supply.

Single direction synchronous geared motors

→ 2 Nm 3 and 3.5 Watts

- Mechanical strength : 2 Nm
- Constant speed, dependent on supply frequency
- Wide range of speeds available
- Direction of rotation controlled by long-life mechanical anti-return
- Permanent magnet rotor
- Silent operation
- UL, CSA, VDE approved, comply with IEC standards



Specifications

		3 Watts	3.5 Watts
Type		82 304 0	82 305 5
Voltage / Frequency		230 V 50 Hz	230 V 50 Hz
Output speed	Ratios		
32 rpm	18.75	●	●
24 rpm	25	●	●
15 rpm	40	●	●
12 rpm	50	●	●
10 rpm	60	●	●
7.5 rpm	80	●	●
6 rpm	100	●	●
5 rpm	120	●	●
3.75 rpm	160	●	●
2.4 rpm	250	●	●
2 rpm	300	●	●
1.11 rpm	540	●	●
1 rpm	600	●	●
0.75 rpm	800	●	●
0.56 rpm	1080	●	●
0.4 rpm	1500	●	●
0.2 rpm	3000	●	●
0.13 rpm	4800	●	●
0.10 rpm	6000	●	●
3/4 rph	27000	●	●
2/3 rph	54000	●	●
1/5 rph	180000	●	●
General characteristics			
Motor		82 340 0	82 330 5
Gearbox		81 033 0	81 033 0
Maximum permitted torque from gearmotor under continuous conditions for 1 millions turns of the gearmotor (N.m)		2	2
Radial load static (daN)		1	1
Axial load static (daN)		10	10
Absorbed power (W)		3	3.5
Motor output (W)		0.16	0.42
Maximum temperature rise (°C)		55	55
Ambient temperature (°C)		-50 → +60	-50 → +60
Weight (g)		250	300
Wires length mm (approximately)		250	250
Protection rating		IP40	IP40

Product adaptations

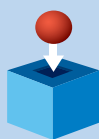

- Special supply voltages
- Special cable lengths
- Special connectors
- Special output shafts
- Special gearbox ratios
- Special gear wheel material
- Special output bearings
- Special mounting plate

To order, see page 13

Curves

Graph of torque versus speed 82 304 0

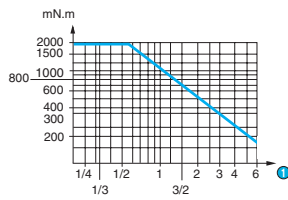

① RPM

Graph of torque versus speed 82 305 0

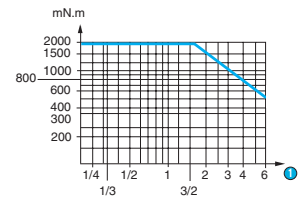

① RPM

Dimensions

82 304 0 - 82 305 5

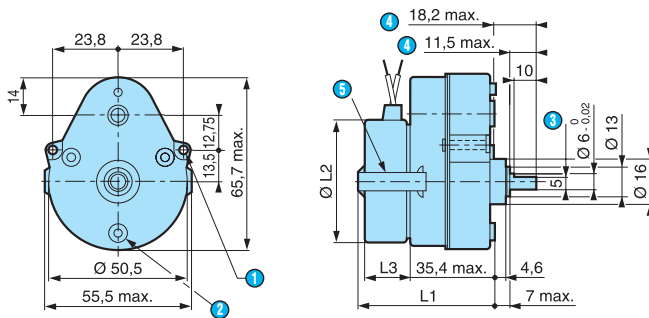

- ① 2 fixing holes $\varnothing 3.2$
- ② 3 mounting bosses $\varnothing 7.2$ at 120° on radius = 19.5 with 3 holes M3 depth 4
- ③ across flat
- ④ (pushed-in shaft \leftarrow)
- ⑤ fixing claw

82 304 0 L1 = 54.8 mm max. / \varnothing L2 = 47.2 mm max. / L3 = 16.9 mm max.
 82 305 5 L1 = 59.85 mm max. / \varnothing L2 = 47.2 mm max. / L3 = 22.9 mm max.

Options

Shaft 79 202 573

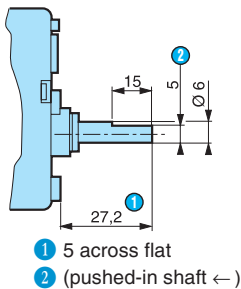

- ① 5 across flat
- ② (pushed-in shaft \leftarrow)

Other information

The speed of a motor powered by a 60 Hz supply is 20 % higher than that of a motor powered by a 50 Hz supply.

4

Single direction synchronous geared motors

→ 3 Nm 3.5 Watts

- Mechanical strength : 3 Nm
- Constant speed, dependent on supply frequency
- Wide range of speeds available
- Direction of rotation controlled by long-life mechanical
- Permanent magnet rotor
- UL, CSA, VDE approved, comply with IEC standards



Specifications

		3.5 Watts
Type		80 333 5
Base speed of motor (rpm)		600
Voltage / Frequency		230-240 V - 50 Hz
Output speed (rpm)	Ratios (i)	
29	20.83	●
14	41.66	●
7	83.33	●
4	150	●
3.2	187.5	●
2	300	●
1.6	375	●
1	600	●
0.8	750	●
0.5	1200	●
0.267	2250	●
0.25	2400	●
0.167	3600	●
General characteristics		
Motor		82 330 5
Gearbox		81 023
Maximum permitted continuous rated gearbox output torque (Nm)		3
Axial load static (daN)		2
Radial load static (daN)		3
Absorbed power (W)		3.5
Motor output (W)		0.42
Maximum temperature rise (°C)		55
Ambient temperature (°C)		-5 → +60
Weight (g)		440
Wires length mm (approximately)		250
Protection rating		IP30

Product adaptations

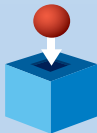

- Special supply voltages
- Special cable lengths
- Special connectors
- Special output shafts
- Special gearbox ratios
- Special gear wheel material
- Special output bearings
- Special mounting plate

To order, see page 13

Curves

Graph of torque versus speed 82 333 5

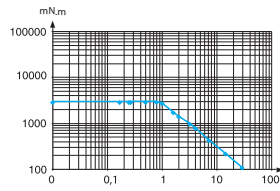

① RPM

Dimensions

80 333 5

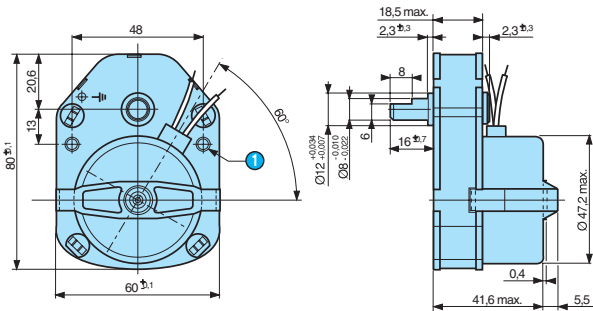

① 2 fixing holes \varnothing 4.1 max.

Other information

The speed of a motor powered by a 60 Hz supply is 20 % higher than that of a motor powered by a 50 Hz supply.

Single direction synchronous geared motors

→ 5 Nm 3.5 Watts

- Mechanical strength : 5 Nm
- Constant speed, dependent on supply frequency
- Speeds from 0.24 rpm to 24 rpm
- Direction of rotation controlled by long-life mechanical anti-return
- Permanent magnet rotor
- UL, CSA, VDE approved, comply with IEC standards



Specifications

			3.5 Watts	3.5 Watts
Type			80 337 5	80 337 5
Voltage / Frequency			230 V 50 Hz	240 V 50 Hz
Direction of rotation	Output speed	Ratios		
Anti-clockwise	24 rpm	25	80 337 506	80 337 524
Anti-clockwise	14.40 rpm	41.66	80 337 509	80 337 534
Anti-clockwise	9.60 rpm	62.5	●	●
Anti-clockwise	7.20 rpm	83.33	●	●
Anti-clockwise	4.80 rpm	125	80 337 514	80 337 528
Anti-clockwise	2.40 rpm	250	80 337 516	80 337 529
Anti-clockwise	1.20 rpm	500	80 337 519	80 337 539
Anti-clockwise	0.80 rpm	750	●	●
Anti-clockwise	0.24 rpm	2500	80 337 523	80 337 541
Clockwise	24 rpm	25	80 337 507	80 337 533
Clockwise	14.40 rpm	41.66	80 337 508	80 337 525
Clockwise	9.60 rpm	62.5	●	●
Clockwise	7.20 rpm	83.33	●	●
Clockwise	4.80 rpm	125	80 337 515	80 337 537
Clockwise	2.40 rpm	250	80 337 517	80 337 538
Clockwise	1.20 rpm	500	80 337 518	80 337 530
Clockwise	0.80 rpm	750	●	●
Clockwise	0.24 rpm	2500	80 337 522	80 337 532
General characteristics				
Motor			82 330 5	82 330 5
Gearbox			81 037 0	81 037 0
Maximum permitted continuous-rated gearbox output torque over 1 million revolutions (N.m)			5	5
Radial load static (daN)			2	2
Axial load static (daN)			3	3
Absorbed power (W)			3.5	3.5
Motor output (W)			0.42	0.42
Maximum temperature rise (°C)			55	55
Ambient temperature (°C)			-5 → +60	-5 → +60
Weight (g)			480	480
Wires length mm (approximately)			250	250
Protection rating			IP40	IP40

Product adaptations

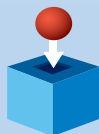

- Special supply voltages
- Special cable lengths
- Special connectors
- Special output shafts
- Special gearbox ratios
- Special gear wheel material
- Special output bearings
- Special mounting plate

To order, see page 13

Dimensions

80 337 5

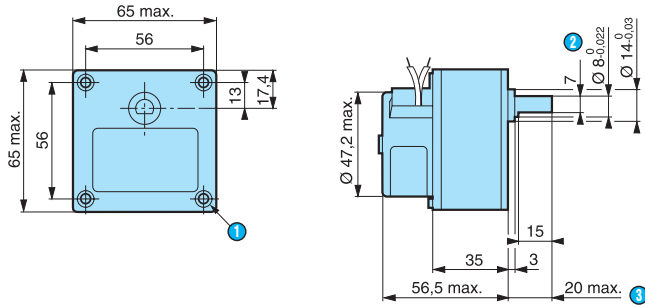

- ① 4 holes M4 depth 12 mm
- ② 7 across flat
- ③ pushed-in shaft

Options

Shaft 79 206 478

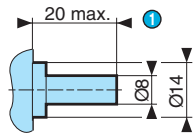

- ① (pushed-in shaft ←)

Other information

The speed of a motor powered by a 60 Hz supply is 20 % higher than that of a motor powered by a 50 Hz supply.

Reversible synchronous geared motors

→ 0.5 Nm 2.7 Watts

- Mechanical strength : 0.5 Nm
- Constant speed, dependent on supply frequency
- Wide range of speeds available
- Direction of rotation controlled by dephasing capacitor
- Permanent magnet rotor
- UL, CSA, VDE approved, comply with IEC standards.



Specifications

			2.7 Watts	2.7 Watts
Type			82 514 0	82 514 5
Standard motor speed (rpm)			250	500
Voltage / Frequency			230-240 V - 50 Hz	230-240 V - 50/60 Hz
Output speed (250 RPM)	Output speed (500 RPM)	Ratios		
25.00 rpm	50.00 rpm	10	●	●
20.00 rpm	40.00 rpm	25/2	●	●
12.50 rpm	25.00 rpm	20	●	●
10.00 rpm	20.00 rpm	25	●	●
5.00 rpm	10.00 rpm	50	●	●
4.00 rpm	8.00 rpm	125/2	●	●
2.50 rpm	5.00 rpm	100	●	●
2.00 rpm	4.00 rpm	125	●	●
1.25 rpm	2.50 rpm	200	●	●
1.00 rpm	2.00 rpm	250	●	●
0.50 rpm	1.00 rpm	500	●	●
General characteristics				
Motor			82 510 0	82 510 5
Gearbox			81 021 0	81 021 0
Base speed of motor (rpm)			250	500
Maximum permitted continuous rated gearbox output torque for 1 million revolutions of gearbox output shaft (Nm)			0.5	0.5
Axial load static (daN)			1	1
Radial load static (daN)			8	8
Absorbed power (W)			2.7	2.7
Motor output (W)			0.31	0.52
Maximum temperature rise (°C)			50	60
Ambient temperature (°C)			-5 → +70	-5 → +60
Weight (g)			140	140
Wires length mm (approximately)			250	250
Protection rating			IP40	IP40

Product adaptations

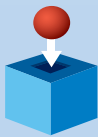

- Special supply voltages
- Special cable lengths
- Special connectors
- Special output shafts
- Special gearbox ratios
- Special gear wheel material
- Special output bearings

Curves

Graph of torque versus speed 82 514 0

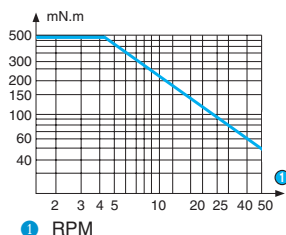

Graph of torque versus speed 82 514 5

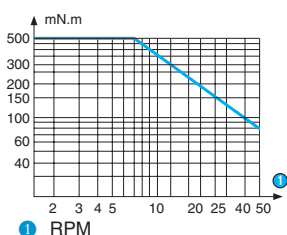

To order, see page 13

Accessories

Voltages/Frequencies	μF	V	Code
Capacitors motor 82 510 0			
230-240 V - 50 Hz	$0.33 \pm 10 \%$	400	26 231 801
115 V - 50/60 Hz	$0.27 \pm 10 \%$	250	26 231 851
24 V - 50 Hz	$8.2 \pm 10 \%$	70	26 231 711
24 V - 60 Hz	$6.8 \pm 10 \%$	63	26 231 708
Capacitors motor 82 510 5			
230-240 V 50/60 Hz	$0.39 \pm 10 \%$	630	21 231 924
115 V 50/60 Hz	$0.39 \pm 10 \%$	630	26 231 924
24 V 50/60 Hz	$8.2 \pm 10 \%$	70	26 231 711

Dimensions

82 514 0 - 82 514 5

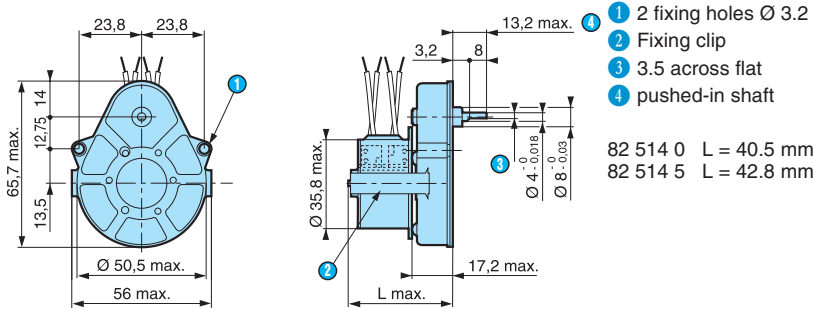

Options

Shaft 79 200 967

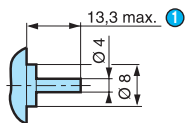

1 (pushed-in shaft ←)

Shaft 79 200 779

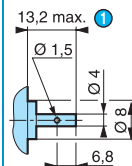

1 (pushed-in shaft ←)

Shaft 70 999 421 SP1295-10

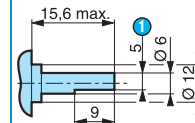

1 5 across flat

Connections

In parallel Motors 82 510 0 - 82 510 5

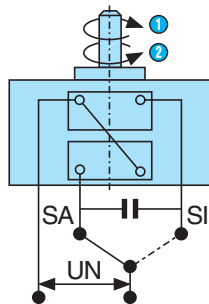

1 SA : Clockwise
2 SI : Anti-clockwise

In series Motors 82 510 0 and 82 510 5 only 230 V - 240 V 50 Hz version

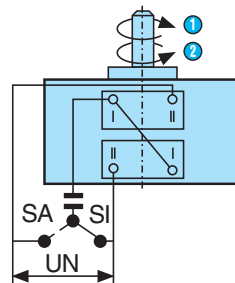

1 SA : Clockwise
2 SI : Anti-clockwise

Other information

The speed of a motor powered by a 60 Hz supply is 20 % higher than that of a motor powered by a 50 Hz supply.

Reversible synchronous geared motors

→ 0.5 Nm 3.5 Watts

- Mechanical strength : 0.5 Nm
- Constant speed, dependent on supply frequency
- Wide range of speeds available
- Direction of rotation controlled by dephasing capacitor
- Permanent magnet rotor
- UL, CSA, VDE approved, comply with IEC standards



Specifications

Type	3.5 Watts		3.5 Watts	
Base speed of motor (rpm)	82 524 0		82 524 4	
Voltage / Frequency	250		375	
	230-240 V - 50 Hz		230-240 V - 50 Hz	
Output speed (250 RPM)	Output speed (375 RPM)	Ratios (i)		
25.00 rpm	37.50 rpm	10	82 524 001	●
20.00 rpm	30.00 rpm	25/2	82 524 002	●
13.33 rpm	20.00 rpm	75/4		
12.50 rpm	18.75 rpm	20	82 524 003	●
10.00 rpm	15.00 rpm	25	82 524 004	●
5.00 rpm	7.50 rpm	50	82 524 008	●
4.00 rpm	6.00 rpm	125/2	82 524 010	●
2.50 rpm	3.75 rpm	100		●
2.00 rpm	3.00 rpm	125		●
1.00 rpm	1.50 rpm	250	82 524 016	●
0.33 rpm	0.50 rpm	750		●
General characteristics				
Motor	82 520 0		82 520 4	
Gearbox	81 021 0		81 021 0	
Maximum permitted continuous rated gearbox output torque for 1 million revolutions of gearbox output shaft (Nm)	0.5		0.5	
Axial load static (daN)	1		1	
Radial load static (daN)	8		8	
Absorbed power (W)	3.5		3.5	
Motor output (W)	0.98		1.12	
Maximum temperature rise (°C)	50		50	
Ambient temperature (°C)	-5 → +70		-5 → +70	
Weight (g)	140		140	
Wires length mm (approximately)	250		250	
Protection rating	IP40		IP40	

Product adaptations

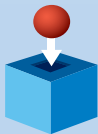

- Special supply voltages
- Special cable lengths
- Special connectors
- Special output shafts
- Special gearbox ratios
- Special gear wheel material
- Special output bearing

Curves

Torque/speed curves 82 524 0

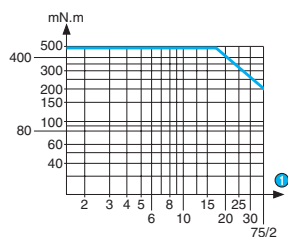

① RPM

Torque/speed curves 82 524 4

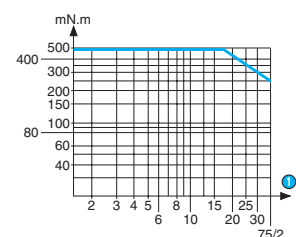

① RPM

To order, see page 13

Accessories

Voltages/Frequencies	μF	V	Code
Capacitors for motor 82 520 0			
230-240 V - 50 Hz	$0.10 \pm 10 \%$	700	26 231 941
115 V 60 Hz	$0.33 \pm 10 \%$	400	26 231 801
24 V - 50 Hz	$8.2 \pm 10 \%$	70	26 231 711
Capacitors motor 82 520 4			
230/240 V - 50 Hz	$0.12 \pm 10 \%$	600	26 231 903
115 V 60 Hz	$0.39 \pm 5 \%$	630	26 231 924
24 V - 50 Hz	$15 \pm 5 \%$	70	26 231 728
24 V - 60 Hz	$12 \pm 5 \%$	63	26 231 145

Dimensions

82 524 0 - 82 524 4

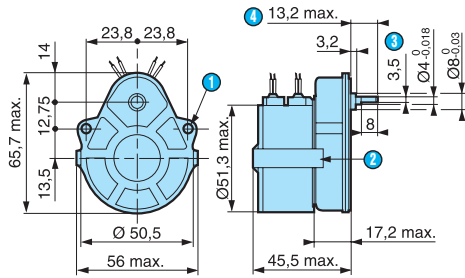

- ① 2 fixing holes $\text{Ø} 3.2$
- ② Fixing clip
- ③ 3.5 across flat
- ④ pushed-in shaft

Options

Shaft 79 200 967

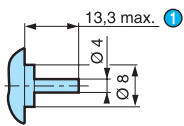

- ① (pushed-in shaft ←)

Shaft 79 200 779

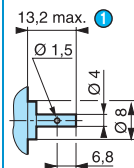

- ① (pushed-in shaft ←)

Shaft 70 999 421 SP1295-10

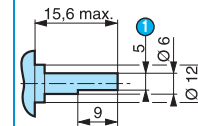

- ① 5 across flat

Connections

In parallel

Motors 82 520 0 - 82 520 4

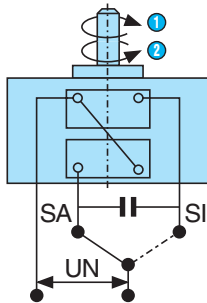

- ① SA : Clockwise
- ② SI : Anti-clockwise

Other information

The speed of a motor powered by a 60 Hz supply is 20 % higher than that of a motor powered by a 50 Hz supply.

Reversible synchronous geared motors

→ 2 Nm 2.7 Watts

- Mechanical strength : 2 Nm
- Constant speed, dependent on supply frequency
- Wide range of speeds available
- Direction of rotation controlled by dephasing capacitor
- Permanent magnet rotor
- UL, CSA, VDE approved, comply with IEC standards.



Specifications

			2.7 Watts	2.7 Watts
Type			82 519 0	82 519 5
Voltage / Frequency			230-240 V - 50 Hz	230-240 V - 50/60 Hz
Base speed of motor (rpm)			250	500
Output speed (250 RPM)	Output speed (500 RPM)	Ratios (i)		
10,00 rpm	20,00 rpm	25	●	●
5,00 rpm	10,00 rpm	50	●	●
2,50 rpm	5,00 rpm	100	●	●
1,00 rpm	2,00 rpm	250	●	●
0,50 rpm	1,00 rpm	500	●	●
0,33 rpm	0,66 rpm	750	●	●
0,16 rpm	0,32 rpm	1500	●	●
5,00 rev/hr	10,00 rev/hr	3000	●	●
General characteristics				
Motor			82 510 0	82 510 5
Gearbox			81 033 0	81 033 0
Maximum permitted continuous rated gearbox output torque for 1 million revolutions of gearbox output shaft Nm			2.0	2.0
Axial load static (daN)			1	1
Radial load static (daN)			10	10
Absorbed power (W)			2.7	2.7
Motor output (W)			0.31	0.52
Maximum temperature rise (°C)			50	60
Ambient temperature (°C)			-5 → +70	-5 → +60
Weight (g)			230	230
Wires length mm (approximately)			250	250
Protection rating			IP40	IP40

Product adaptations

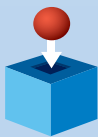

- Special supply voltages
- Special cable lengths
- Special connectors
- Special output shafts
- Special gearbox ratios
- Special gear wheel material
- Special output bearings

Curves

Graph of torque versus speed 82 519 0

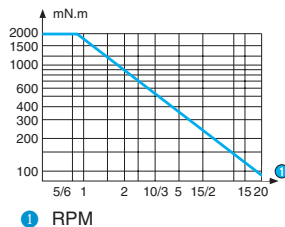

Graph of torque versus speed 82 519 5

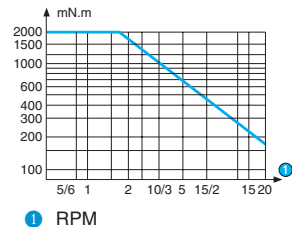

To order, see page 13

Accessories

Voltages/Frequencies	μF	V	Code
Capacitors for motor 82 510 0			
230-240 V - 50 Hz	$0.33 \pm 10 \%$	400	26 231 801
115 V - 50/60 Hz	$0.27 \pm 10 \%$	250	26 231 851
24 V - 50 Hz	$8.2 \pm 10 \%$	70	26 231 711
24 V - 60 Hz	$6.8 \pm 10 \%$	63	26 231 708
Capacitors for motor 82 510 5			
230-240 V - 50/60 Hz	$0.39 \pm 10 \%$	630	26 231 924
115 V - 50/60 Hz	$0.39 \pm 10 \%$	630	26 231 924
24 V - 50/60 Hz	$8.2 \pm 10 \%$	70	26 231 711

Dimensions

82 519 0 - 82 519 5

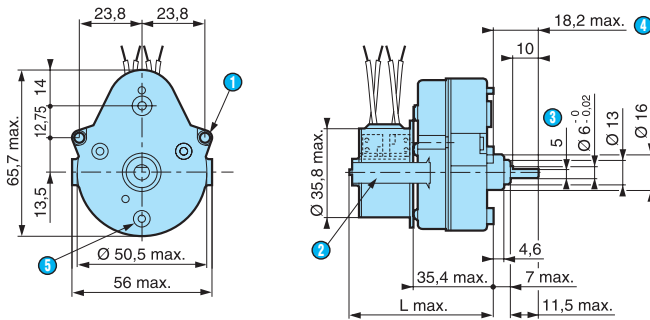

- 1 2 fixing holes $\text{Ø} 3.2$
- 2 Fixing clip
- 3 5 across flat
- 4 pushed-in shaft

82 519 0 L = 58.7 mm
82 519 5 L = 61 mm

Options

Shaft 79 200 967

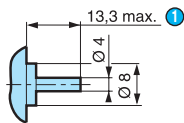

- 1 (pushed-in shaft ←)

Shaft 79 200 779

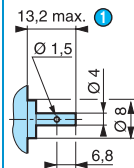

- 1 (pushed-in shaft ←)

Shaft 79 999 421- SP1295-10

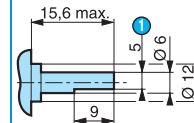

- 1 5 across flat

Connections

In parallel

Motors 82 510 0 - 82 510 5

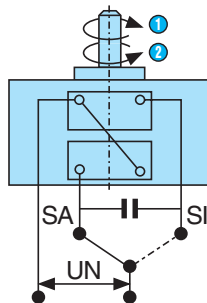

- 1 SA : Clockwise
- 2 SI : Anti-clockwise

In series

Motors 82 510 0 and 82 510 5 only 230 V - 240 V 50 Hz version

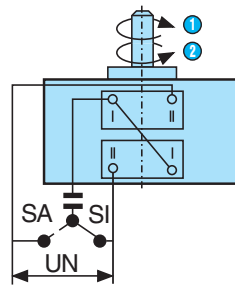

- 1 SA : Clockwise
- 2 SI : Anti-clockwise

Other information

The speed of a motor powered by a 60 Hz supply is 20 % higher than that of a motor powered by a 50 Hz supply.

Reversible synchronous geared motors

→ 2 Nm 3.5 Watts

- Mechanical strength : 2 Nm
- Constant speed, dependent on supply frequency
- Wide range of speeds available
- Direction of rotation controlled by dephasing capacitor
- Permanent magnet rotor
- UL, CSA, VDE approved, comply with IEC standards



Specifications

	3.5 Watts		3.5 watts	
Type	82 529 0		82 529 4	
Voltage / Frequency	230-240 V - 50 Hz		230-240 V - 50 Hz	
Base speed of motor (rpm)	250		375	
Output speed (250 RPM)	Output speed (375 RPM)	Ratios (i)		
10.00 rpm	15.00 rpm	25	●	●
5.00 rpm	7.50 rpm	50	●	●
4.00 rpm	6.00 rpm	125/2	-	●
2.50 rpm	3.75 rpm	100	●	●
1.00 rpm	1.50 rpm	250	●	●
0.50 rpm	0.75 rpm	500	●	●
0.33 rpm	0.50 rpm	750	●	●
5.00 rev/hr	7.50 rev/hr	3000	●	●
General characteristics				
Motor	82 520 0		82 520 4	
Gearbox	81 033 0		81 033 0	
Maximum permitted continuous rated gearbox output torque for 1 million revolutions of gearbox output shaft Nm	2.0		2.0	
Axial load static (daN)	1		1	
Radial load static (daN)	10		10	
Absorbed power (W)	3.5		3.5	
Motor output (W)	0.98		1.12	
Maximum temperature rise (°C)	50		50	
Ambient temperature (°C)	-5 → +70		-5 → +70	
Weight (g)	260		350	
Wires length mm (approximately)	250		250	
Protection rating	IP40		IP40	

Product adaptations

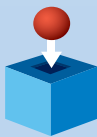

- Special supply voltages
- Special cable lengths
- Special connectors
- Special output shafts
- Special gearbox ratios
- Special gear wheel material
- Special output bearings

Curves

Torque/speed curves 82 529 0

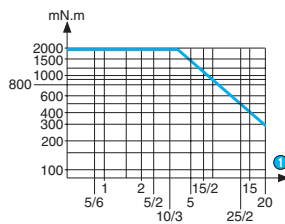

① RPM

Torque/speed curves 82 529 4

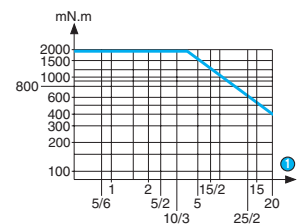

① RPM

To order, see page 13

Accessories

Voltages/Frequencies	μF	V	Code
Capacitors for motor 82 520 0			
230-240 V - 50 Hz	$0.10 \pm 10 \%$	700	26 231 941
115 V - 60 Hz	$0.33 \pm 10 \%$	400	26 231 801
24 V - 50 Hz	$8.2 \pm 10 \%$	70	26 231 711
Capacitors for motor 82 520 4			
230/240 V - 50 Hz	$0.12 \pm 10 \%$	600	26 231 903
115 V - 60 Hz	$0.39 \pm 5 \%$	630	26 231 924
24 V - 50 Hz	$15 \pm 5 \%$	70	26 231 728
24 V - 60 Hz	$12 \pm 5 \%$	63	26 231 145

Dimensions

82 529 0 - 82 529 4

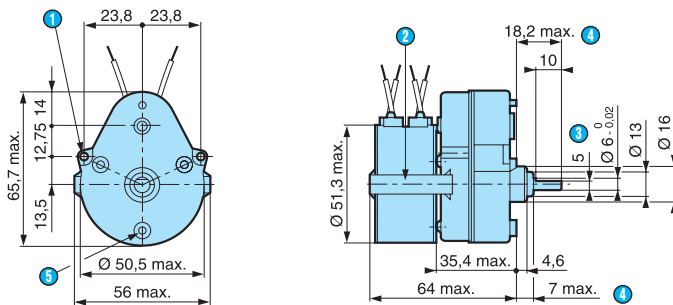

- 1 2 fixing holes $\text{Ø} 3.2$
- 2 Fixing clip
- 3 5 across flat
- 4 (pushed-in shaft \leftarrow)
- 5 3 mounting bosses $\text{Ø} 7.2$ at 120°
on radius= 19.5 - 3 holes M3 depth 4

Options

Shaft 79 202 573

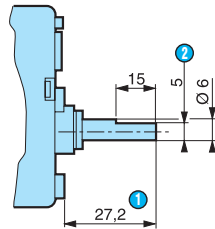

- 1 (shaft pushed-in \leftarrow)
- 2 5 across flat

Connections

In parallel Motors 82 520 0 - 82 520 4

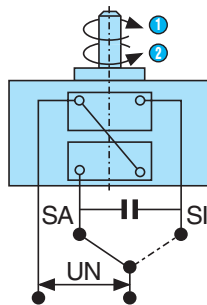

- 1 SA : clockwise
- 2 SI : anti-clockwise

Other information

The speed of a motor powered by a 60 Hz supply is 20 % higher than that of a motor powered by a 50 Hz supply.

Reversible synchronous geared motors

→ 3 Nm 2.7 Watts

- Mechanical strength : 3 Nm
- Constant speed, dependent on supply frequency
- Direction of rotation controlled by dephasing capacitor
- Permanent magnet rotor
- UL, CSA, VDE approved, comply with IEC standards



Specifications

			2.7 Watts	2.7 Watts
Type			80 513 0	80 513 5
Voltages/Frequencies			230-240 V 50 Hz	230-240 V 50 Hz
Base speed of motor (rpm)			250	500
Output speed (250 RPM)	Output speed (500 RPM)	Ratios (i)		
12	24	20.83	●	●
6	12	41.66	●	●
3	6	83.33	●	●
1.667	3.333	150	●	●
1.333	2.667	187.5	●	●
0.833	1.667	300	●	●
0.667	1.333	375	●	●
0.417	0.833	600	●	●
0.333	0.667	750	●	●
0.208	0.417	1200	●	●
0.111	0.222	2250	●	●
0.104	0.208	2400	●	●
0.069	0.139	3600	●	●
General characteristics				
Motor			82 510 0	82 510 5
Gearbox			81 023 0	81 023 0
Maximum permitted continuous rated gearbox output torque (Nm)			3	3
Axial load static (daN)			2	2
Radial load static (daN)			3	3
Absorbed power (W)			2.7	2.7
Motor output (W)			0.31	0.52
Maximum temperature rise (°C)			55	65
Ambient temperature (°C)			-10 → +75	-5 → +65
Weight (g)			370	370
Wires length mm (approximately)			250	250
Protection rating			IP00	IP00

Product adaptations

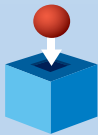

- Special supply voltages
- Special cable lengths
- Special connectors
- Special output shafts
- Special gearbox ratios
- Special gear wheel material
- Special output bearings
- Special mounting plate

To order, see page 13

Curves

Torque / speed curves 80 513 0

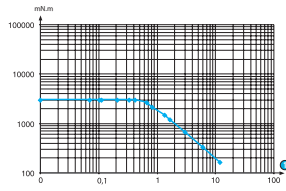

① RPM

Torque / speed curves 80 513 5

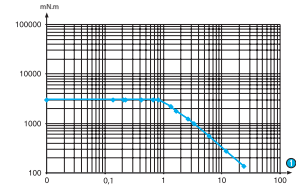

① RPM

Accessories

Voltages/Frequencies	μF	V	Code
Capacitors for motor 82 510 0			
230-240 V - 50 Hz	$0.33 \pm 10 \%$	400	26 231 801
115 V - 50/60 Hz	$0.27 \pm 10 \%$	250	26 231 851
24 V - 50 Hz	$8.2 \pm 10 \%$	70	26 231 711
24 V - 60 Hz	$6.8 \pm 10 \%$	63	26 231 708
Capacitors for motor 82 510 5			
230-240 V - 50/60 Hz	$0.39 \pm 10 \%$	630	26 231 924
115 V - 50/60 Hz	$0.39 \pm 10 \%$	630	26 231 924
24 V - 50/60 Hz	$8.2 \pm 10 \%$	70	26 231 711

Dimensions

80 513 0/5

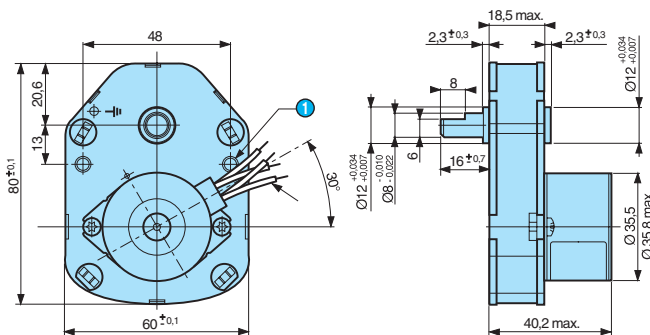

① 2 fixing holes $\varnothing 4.1$ max.

Other information

The speed of a motor powered by a 60 Hz supply is 20 % higher than that of a motor powered by a 50 Hz supply.

Reversible synchronous geared motors

→ 3 Nm 3.5 Watts

- Mechanical strength : 3 Nm
- Constant speed, dependent on supply frequency
- Direction of rotation controlled by dephasing capacitor
- Permanent magnet rotor
- UL, CSA, VDE approved, comply with IEC standards



Specifications

		3.5 Watts	3.5 Watts
Type		80 523 0	80 533 0
Voltages/Frequencies		230-240 V 50 Hz	230-240 V 50 Hz
Base speed of motor (rpm)		250	250
Output speed (250 RPM)	Ratios (i)		
12	20.83	●	●
6	41.66	●	●
3	83.33	●	●
1.667	150	●	●
1.333	187.5	●	●
0.833	300	●	●
0.667	375	●	●
0.417	600	●	●
0.333	750	●	●
0.208	1200	●	●
0.111	2250	●	●
0.104	2400	●	●
0.069	3600	●	●
General characteristics			
Motor		82 520 0	82 530 0
Gearbox		81 023 0	81 023 0
Maximum permitted continuous rated gearbox output torque (Nm)		3	3
Axial load static (daN)		2	2
Radial load static (daN)		3	3
Absorbed power (W)		3.5	3.6
Motor output (W)		0.98	1.37
Maximum temperature rise (°C)		55	45
Ambient temperature (°C)		-10 → +75	-10 → +85
Weight (g)		490	620
Wires length mm (approximately)		250	250
Protection rating		IP00	IP00

Product adaptations

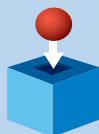

- Special supply voltages
- Special cable lengths
- Special connectors
- Special output shafts
- Special gearbox ratios
- Special gear wheel material
- Special output bearings
- Special mounting plate

To order, see page 13

Curves

Torque / speed curves 80 523 0

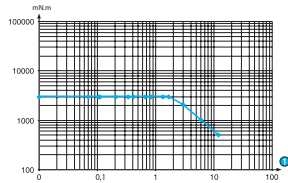

① RPM

Torque / speed curves 80 533 0

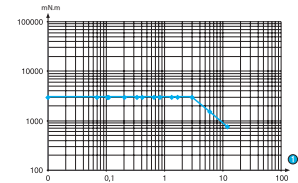

① RPM

Accessories

Voltages/Frequencies	μF	V	Code
Capacitors for motor 82 520 0			
230-240 V - 50 Hz	$0.10 \pm 10\%$	700	26 231 941
115 V - 60 HZ	$0.33 \pm 10\%$	400	26 231 801
24 V - 50 Hz	$8.2 \pm 10\%$	70	26 231 711
Capacitors for motor 82 530 0			
230-240 V - 50 Hz	$0.10 \pm 10\%$	700	26 231 941
115 V - 50/60 Hz	$0.39 \pm 10\%$	630	26 231 924
24 V - 50 Hz	$10 \pm 5\%$	100	26 231 720
24 V - 60 Hz	$6.8 \pm 10\%$	63	26 231 708

Dimensions

80 523 0

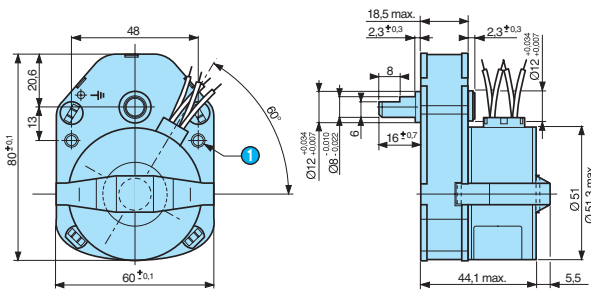

① 2 fixing holes $\text{Ø} 4.1$ max.

80 533 0

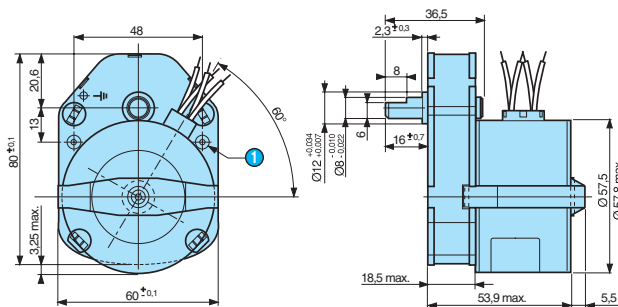

① 2 fixing holes M4 x 11

Other information

The speed of a motor powered by a 60 Hz supply is 20 % higher than that of a motor powered by a 50 Hz supply.

Reversible synchronous geared motors

→ 5 Nm 2.7 and 3.5 Watts

- Mechanical strength : 5 Nm
- Constant speed, dependent on supply frequency
- Direction of rotation controlled by dephasing capacitor
- Permanent magnet rotor
- UL, CSA, VDE approved ; comply with IEC standards



Specifications

Type
Voltage / Frequency
Base speed of motor (rpm)

2.7 watts

80 517 0
230-240 V / 50 Hz
250

3.5 Watts

80 527 0
230-240 V / 50 Hz
250

Output speed (250 RPM)	Output speed (375 RPM)	Ratios
20 rpm	30 rpm	12.5
10 rpm	15 rpm	25
8 rpm	12 rpm	31.25
6 rpm	9 rpm	41.66
4 rpm	10 rpm	62.5
3 rpm	4.5 rpm	83.33
2 rpm	3 rpm	125
1 rpm	1.5 rpm	250
0.5 rpm	0.75 rpm	500
0.33 rpm	0.5 rpm	750
0.1 rpm	0.15 rpm	2500

●	80 527 010
●	80 527 001
●	●
●	80 527 002
●	80 527 003
●	●
●	80 527 005
●	80 527 006
●	●
●	80 527 008
●	●

General characteristics

Motor	82 510 0	82 520 0
Gearbox	81 037 0	81 037 0
Maximum permitted continuous rated gearbox output torque for 1 million revolutions of gearbox output shaft (Nm)	5	5
Axial load static (daN)	2	2
Radial load static (daN)	3	3
Absorbed power (W)	2.7	3.5
Motors output (W)	0.31	0.98
Maximum temperature rise (°C)	50	50
Ambient temperature (°C)	-10 → +70	-10 → +70
Weight (g)	410	530
Wires length mm (approximately)	250	250
Protection rating	IP40	IP40

Product adaptations

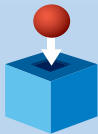

- Special supply voltages
- Special cable lengths
- Special connectors
- Special output shafts
- Special gearbox ratios
- Special gear wheel material
- Special output bearings

Curves

Torque/speed curves 80 517 0

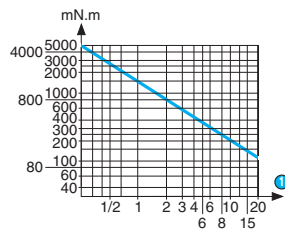

① RPM

Torque/speed curves 80 527 0

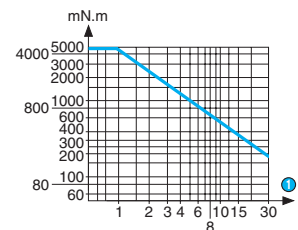

① RPM

To order, see page 13

Accessories

Voltages/Frequencies	μF	V	Code
Capacitors for motor 82 510 0			
230-240 V - 50 Hz	$0.33 \pm 10 \%$	400	26 231 801
115 V - 50/60 Hz	$0.27 \pm 10 \%$	250	26 231 851
24 V - 50 Hz	$8.2 \pm 10 \%$	70	26 231 711
24 V - 60 Hz	$6.8 \pm 10 \%$	63	26 231 708
Capacitors for motor 82 520 0			
230-240 V - 50 Hz	$0.10 \pm 10 \%$	700	26 231 941
115 V - 60 Hz	$0.33 \pm 10 \%$	400	26 231 801
24 V - 50 Hz	$8.2 \pm 10 \%$	63	26 231 711

Dimensions

80 517 0 - 80 527 0

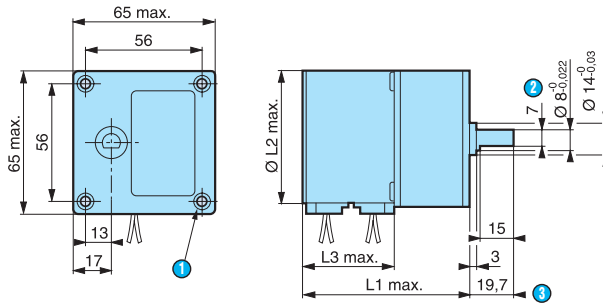

- ① 4 holes M4 depth 12
- ② 7 across flat
- ③ (pushed-in shaft ←)

80 517 0 L1 = 55.3 mm Ø L2 = 35.8 mm L3 = 21.7 mm
 80 527 0 L1 = 59.2 mm Ø L2 = 51.3 mm L3 = 25.6 mm

Options

Shaft 79 206 478

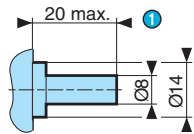

- ① (pushed-in shaft ←)

Connections

In parallel
 Motors 82 510 0 - 82 520 0

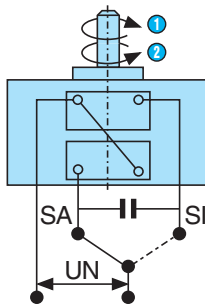

- ① SA : clockwise
- ② SI : anti-clockwise

In series
 Motor 82 510 0 only 230 V - 240 V 50 Hz version

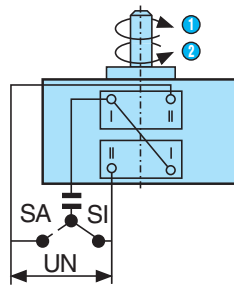

- ① SA : clockwise
- ② SI : anti-clockwise

Other information

The speed of a motor powered by a 60 Hz supply is 20 % higher than that of a motor powered by a 50 Hz supply.

Reversible synchronous geared motors

→ 5 Nm 3.5 and 7.2 Watts

- Mechanical strength : 5 Nm
- Constant speed, dependent on supply frequency
- Direction of rotation controlled by dephasing capacitor
- Permanent magnet rotor
- UL, CSA, VDE approved ; comply with IEC standards



Specifications

Type	3.5 Watts		7.2 Watts	
Voltage / Frequency	80 527 4		80 547 0	
Base speed of motor (rpm)	230-240 V / 50 Hz		230-240 V / 50 Hz	
Output speed (250 RPM)	375		250	
	Output speed (250 RPM)	Output speed (375 RPM)	Ratios	
	20 rpm	30 rpm	12.5	80 547 024
	10 rpm	15 rpm	25	80 547 015
	8 rpm	12 rpm	31.25	80 547 016
	6 rpm	9 rpm	41.66	80 547 017
	4 rpm	10 rpm	62.5	80 547 018
	3 rpm	4.5 rpm	83.33	80 547 019
	2 rpm	3 rpm	125	80 547 020
	1 rpm	1.5 rpm	250	80 547 021
	0.5 rpm	0.75 rpm	500	
	0.33 rpm	0.5 rpm	750	
	0.1 rpm	0.15 rpm	2500	
General characteristics				
Motor	82 520 4		82 540 0	
Gearbox	81 037 0		81 037 0	
Maximum permitted continuous rated gearbox output torque for 1 million revolutions of gearbox output shaft (Nm)	5		5	
Axial load static (daN)	2		2	
Radial load static (daN)	3		3	
Absorbed power (W)	3.5		7.2	
Motors output (W)	1.12		2.65	
Maximum temperature rise (°C)	50		55	
Ambient temperature (°C)	-10 → +70		-10 → +70	
Weight (g)	530		860	
Wires length mm (approximately)	250		250	
Protection rating	IP40		IP40	

Product adaptations

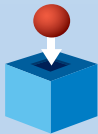

- Special supply voltages
- Special cable lengths
- Special connectors
- Special output shafts
- Special gearbox ratios
- Special gear wheel material
- Special output bearings

Curves

Torque/speed curves 80 527 4

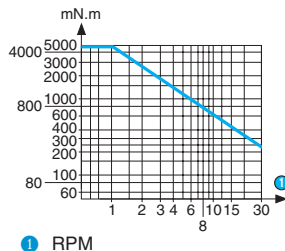

① RPM

Torque/speed curves 80 547 0

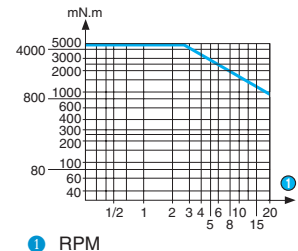

① RPM

To order, see page 13

Accessories

Voltages/Frequencies	μF	V	Code
Capacitors for motors 82 520 4			
230/240 V - 50 Hz	$0.12 \pm 10 \%$	600	26 231 903
115 V - 60 Hz	$0.39 \pm 5 \%$	630	26 231 924
24 V - 50 Hz	$15 \pm 5 \%$	70	26 231 728
24 V - 60 Hz	$12 \pm 5 \%$	63	26 231 145
Capacitors for motor 82 540 0			
230-240 V 50 Hz	$0.22 \pm 5 \%$	630	26 231 909
115 V - 60 Hz	$0.56 \pm 5 \%$	400	26 231 822
24 V - 50 Hz	$22 \pm 10 \%$	63	26 231 703
24 V - 60 Hz	$15 \pm 5 \%$	70	26 231 728

Dimensions

80 527 4 - 80 547 0

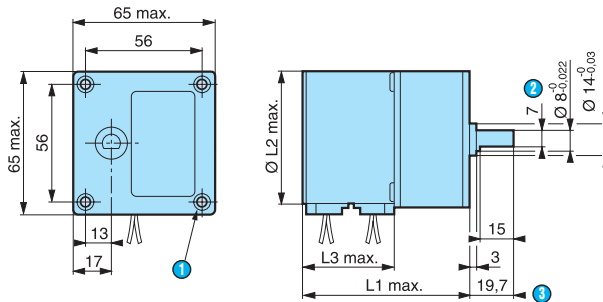

- ① 4 holes M4 depth 12
- ② 7 across flat
- ③ (pushed-in shaft ←)

80 527 4 L1 = 59.2 mm \varnothing L2 = 51.3 mm L3 = 25.6 mm
 80 547 0 L1 = 76.6 mm \varnothing L2 = 65.3 mm L3 = 43 mm

Options

Shaft 79 206 478

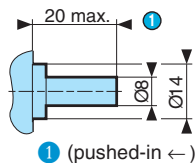

- ① (pushed-in ←)

Connections

In parallel
 Motors 82 520 4 - 82 540 0

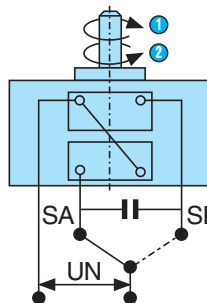

- ① SA : clockwise
- ② SI : anti-clockwise













Other information

The speed of a motor powered by a 60 Hz supply is 20 % higher than that of a motor powered by a 50 Hz supply.









Stepper motors

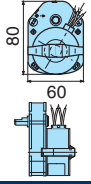
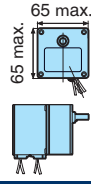

Guide to selecting stepper motors

Gearbox		Max. torque (Nm)		Type of gearbox		0.5	2
						81 021	81 033
Moteurs directs						 65,7 max. 56 max.	 65,8 max. 56 max.
Absorbed power (W)	Holding torque (Nm)		Number of phases	Motor type dimensions (mm)			
	2 phases	4 phases					
5	25	20	24	▶146/148	82 910 Ø 35/50 	▶158 82 914 	▶160 82 919 
5	20	15	48	▶150	82 910 Ø 35/50 	▶158 82 914 	
7,5	70	57	48	▶152	82 920 Ø 51/77 	▶158 82 924 	▶160 82 929 
10	180	155	48	▶154	82 930 Ø 58/79 		
12,5	300	240	48	▶156	82 940 65 x 65 		



3	5
81 023	81 037
	
▶162 80 913 	▶164 80 917 
▶162 80 913 	
▶162 80 923 	▶164 80 927 
▶162 80 933 	
	▶166 80 947 

The advantages of stepper motor

It is useful to examine the principal characteristics of stepper motors and evaluate their advantages

Characteristics	Advantages
No brushes	No wear, therefore long operating life
Open loop operation	No need for encoder or emulator (cost reduction)
Several step angles available	Provides optimum characteristics for the resolution of speed/load.
Direct motor drive from a digital signal	Easy integration into a complex system

The basic advantage of a stepper motor is that it can operate within an open loop, that is to say that in normal operating conditions, for n impulses one obtains n steps.

Stepper motors are found in numerous applications such as : photocopiers, typewriters, bank printers, computer peripherals, x-y plotters, instrumentation, medical pumps, drip feeders, vending machines, gaming machines, automobiles, heating and ventilation and process control.

Principles of stepper motors

The operation of a stepper motor requires the presence of the following elements :

- A control unit (a micro-processor for example) which supplies impulses the frequency of which is proportional to the speed of the motor. This applies equally to both directions of rotation;
- A sequencer which will direct the impulses to the various motor coils.
- A power supply.

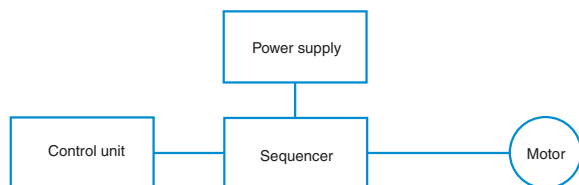

→ The variable reluctance stepper motor

This type of motor functions according to the Law of maximum flux.

Constitution :

- A stator with teeth
- A rotor with teeth

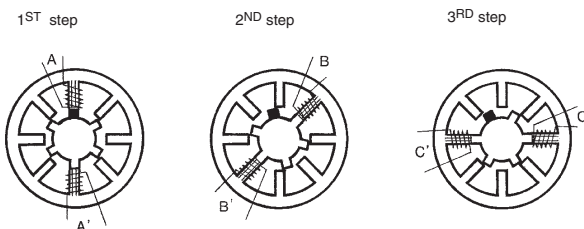

→ The permanent magnet stepper motor

Constitution :

- A stator with teeth
- A magnetised rotor

→ 2-phase motor - two-pole supply

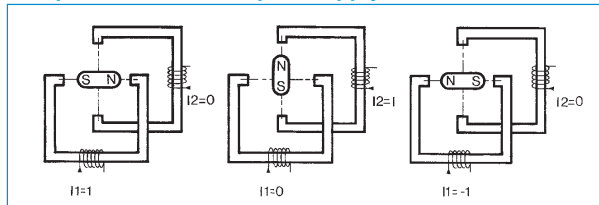

→ 4-phase motor - single-pole supply

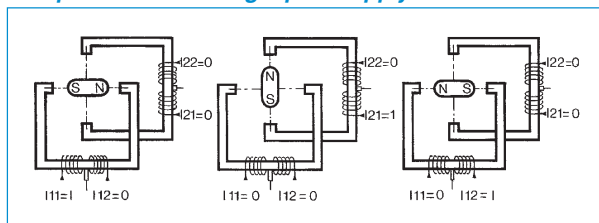

Different types of energisation

→ 2 phases

	I1	I2	°
1 phase on	1	0	0
	0	1	90
	-1	0	180
	0	-1	270
2 phases on	1	1	45
	-1	1	135
	-1	-1	225
	1	-1	315
1/2 step	1	0	0
	0	1	90
	-1	1	135
	-1	0	180
	-1	-1	225
	0	-1	270
	1	-1	315

→ 4 phases

	I11	I12	I21	I22	°
1 phase on	1	0	0	0	0
	0	0	1	0	90
	0	1	0	0	180
	0	0	0	1	270
2 phases on	1	0	1	0	45
	0	1	1	0	135
	0	1	0	1	225
	1	0	0	1	315
1/2 step	1	0	0	0	0
	1	0	1	0	45
	0	0	1	0	90
	0	1	1	0	135
	0	1	0	0	180
	0	1	0	1	225
	0	0	0	1	270
	1	0	0	1	315

Static characteristics

→ Current per phase

This is the current rating per phase at zero frequency (motor stopped) which produces the maximum permitted temperature rise for the motor in operation. This current is measured when power & voltage are constant.

→ Static holding torque

With the motor energised, the static holding torque is the torque which must be applied via the motor shaft to induce continuous rotation.

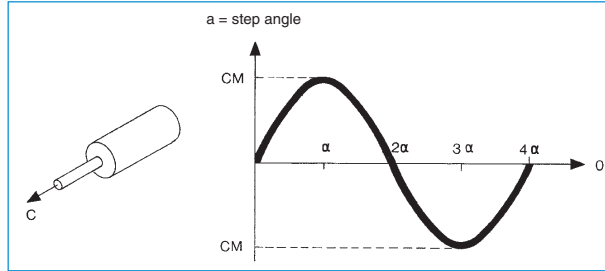

→ Holding torque (Cm)

The holding torque is the minimum torque which needs to be applied to the rotor for it to turn, measurement being made with the «motor energised two phases at a time» at zero frequency.

→ Detent torque

This torque has the same definition as the holding torque but with the motor de-energised.

Dynamic characteristics

→ Elementary movement

There are 4 types of constraints which can influence a motor :

The inertial load JL

This factor only affects the motor during acceleration or deceleration, and also influences the resonant frequency. If JL is the result of the load inertia (directly applied to the motor shaft) the equivalent torque caused by this inertia is a function of the transmission system (see later section concerning mechanical aspects).

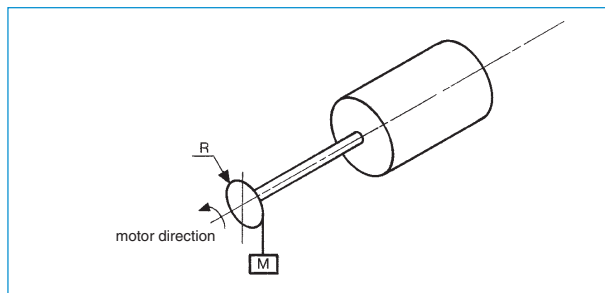

The antagonistic torque MR

This is the torque which opposes the general rotation of the motor. A pulley and weight system best exemplifies this torque.

The resistive torque caused by viscous friction

This is proportional to the speed. By definition, this friction represents the result of the actions of a liquid or a gas on a solid which moves through liquid or gas. Cars and aircraft are good examples of this.

The resistive torque caused by dry friction

This is always against the direction of movement. By definition, this friction represents the result of actions applied on a solid moving against another solid.

Example of the paper feed on a printer.

Inertias:

J pinions + J gears + J rollers. These inertias must be applied to the motor shaft.

Antagonistic torque:

This is the weight of the paper. It is not significant compared to the dry friction torque.

Viscous friction torque:

This torque caused by the displacement of the roller in air is negligible.

Dry friction torque:

This is the torque caused by the friction of the different shafts (gears and rollers) on their bearings.

Up to now, we have mentioned the external constraints but there are constraints caused by inertia, viscous friction and dry friction inside the motor.

Inertia:

Inertia of the rotor.

Viscous friction:

- Friction of the rotor in the air.
- Resistive torque caused by resulting air flow of which the effect is the equivalent of viscous torque.

Dry friction:

For a given system, the variation of the antagonistic torque and the frequency of the drive impulses determine the dynamic characteristics of the motor.

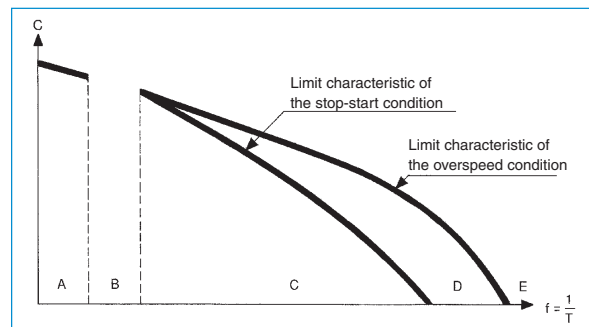

→ Dynamic torques

For a given system, the variation of the antagonistic torque and the frequency of the drive impulses determine the dynamic characteristics of the motor, for one power value.

Zone A

Operation possible but risk of excessive noise generation due to motor shocks.

Zone B

Risk of loss of synchronisation : low frequency resonance.

Zone C

Stop-start zone.
Starting and stopping of the motor in this zone without loss of step.

Zone D

Overspeed zone.
Operation possible if the stopping and starting occur in zone C.

Zone E

Operation impossible.

→ Remarks on a given specification

For a given type of motor and number of phases several coil types are available. They have been developed in order to adapt the motor to each type of electronic control.

For example :

a low resistance is required for a DC supply and a higher resistance will be appropriate for a constant voltage supply. However, all the coil types are roughly equivalent from the point of view of power absorbed, ampere/revolution and the (L/R) time constant (static).

These motors will have about the same performance for a given type of electronic control.

Example motor 82 910 - 2 phases.

		82 910 001	82 910 005	82 910 022
R	Ω	9	12.9	66
L	H	12	15	68
N	tr	320	373	762
I e	A	0.52	0.44	0.19
NI	A.tr	166.4	164	145
P	W	4.9	5	4.8
Z=L/R	ms	1.3	1.15	1

→ Step precision

Condition : (full stepping with 2 phases energised)

The external loads are nil, the current is at its nominal value. Measurement is made on all the steps and for a complete rotation.

Definition:

Positioning precision

This is the variance with the theoretical equilibrium position.

Step precision

This is the variance of the movement angle (step)

→ Influence of the inertia of the load

Fo - Maximum frequency of stopping-starting with no load inertia

JR - Inertia of the rotor

JL - Inertia of the load

Note :

The above formula is determined using the approximation JL ~ JR

Power supplies

→ Notation

One phase of the motor has a resistance R and an inductance L

→ Constant voltage supply

without a series resistor

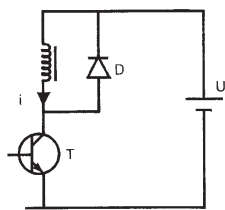

with a series resistor

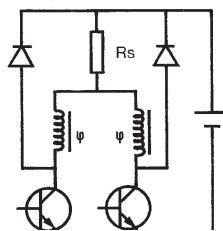

The use of a series resistor necessitates the increase of the supply voltage from :

U to $\frac{R + R_0}{R} U$ in order to maintain the same absorbed power to the motor.

→ Two-level voltage supply

All the improvements are based on increasing the ramp at the source of the current in the (R-L) circuit.

The first method consists of increasing the total resistance of the circuit. The second method consists of increasing the supply voltage for a certain time, with the average power dissipated within the motor not producing a temperature rise above that permitted.

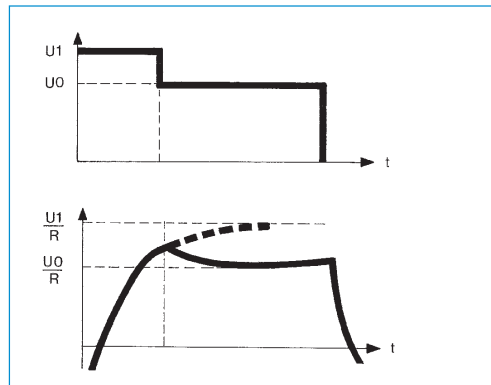

→ Constant current supply

The supply voltage is considerably higher than the nominal RI. The current is regulated by a transistor functioning in digital mode following the given principle of chopper supplies

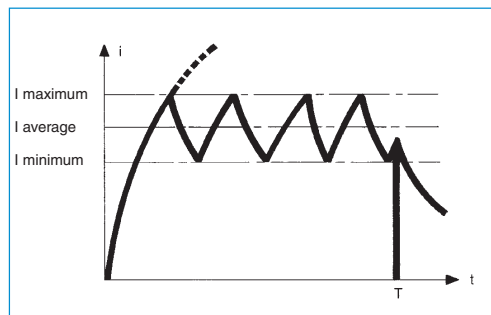

Comparisons

→ Energisation «one phase at a time» «two phases at a time»

Comparison at the same absorbed power

	1 phase at a time	2 phases at a time
Power	$P = R (\sqrt{2}I)^2$	$P = 2RI^2$
Current per phase	$\sqrt{2} I$	I
Holding torque	$\sqrt{2}$	$\sqrt{2} Cm$

The holding torque is proportional to the current and is linear in the magnetic region. Beyond this, the phenomenon of saturation renders the holding torque almost independent of the current.

Cm1 = Holding torque produced by phase 1 supplied by I

Cm2 = Holding torque produced by phase 2 supplied by I

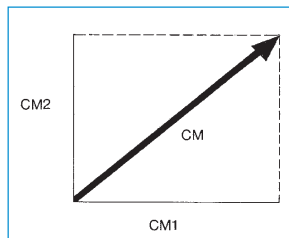

C_m = Holding torque of the motor energised «two phases at a time»

→ Comparison «2 phases» - «4 phases»

Comparison with constant voltage and resistance.

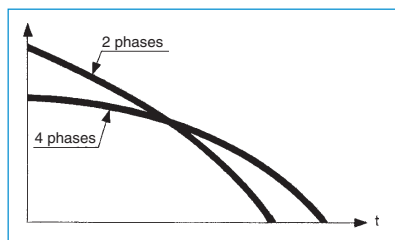

Comparison of the «2 phases» and «4 phases» motor supplied at constant voltage

	2 phases	4 phases
Performance	High in low frequency Low in high frequency	High in low frequency
Motor price	Low	Supplement to cover 6 leads
Electronics	8 transistors	4 transistors

Approvals

→ Permanent magnet stepper motors

The standard connection leads AWG22 are approved to UL 80°C, 300V. (AWG24 available on request).

→ Hybrid stepper motors

The standard connection leads AWG22 are approved to UL 125°C, 300V. UL 325 - 6 CSA

→ Other hybrid steppers versions

Certain hybrid motors can be supplied in 2 phase (4 leads) or 4 phase (8 leads). The motors are marked as follow.

A - Connections in series

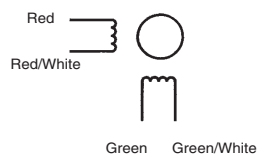

B - Connections in parallel

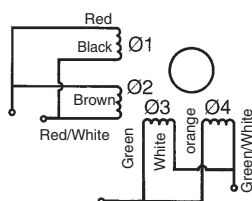
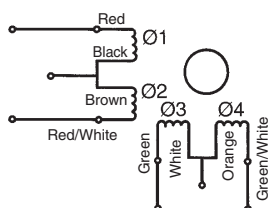
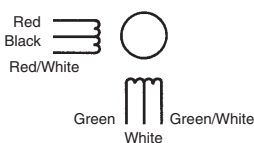

Notes

In this catalogue, each motor shown has an 8-digit part number which is a complete definition. To avoid any error, this part number should appear on orders.

How to define your requirements

The stepper motor can satisfy numerous applications : to find the right motor for your application, certain points require definition :

→ Mechanical characteristics

Define clearly your system and your drive layout in order to evaluate the frictions and inertias as they apply to the motor shaft (see appendix covering mechanical aspects).

Define your transmission mode. Determine the usable torque, in dynamic and holding form.

Determine the number of steps to accomplish and the time allocated for this movement.

Select an operating speed.

Select a supply mode (constant voltage, two voltage levels, constant current).

Should the motor selected produce the necessary torque at the required frequency but in the overspeed zone, do not forget to ramp up and down to prevent any loss of step.

Determination of conditions of use : temperature, axial and radial load, operational frequency. In certain cases the use of a gearbox will provide extra torque and speed; for such cases refer to curves in the catalogue to indicate the usable power and 3/15speed available.

→ Specific requirements

Elements to provide to define a motor correctly if you do not find the product you need in the catalogue:

Dimensions, step angle, resistance, number of phases, lead length, type of connector, supply type, operating frequency, required torque, operating cycle.

But if your application requires special shafts or other mechanical or electric adaptations (pinions, connectors etc) our staff are at your disposal (for significant quantities). We point out as well that numerous adaptations exist as standard or semi-standard versions.

MECHANICAL ASPECTS

Wheel/screw system

$$J = J_v + \frac{1}{R^2} J_r$$

J_v = Inertia considered as a cylinder of a diameter equal to the initial diameter.

J_r = Inertia of the wheel considered as a whole cylinder of a diameter equal to the initial diameter.

R = Reduction ratio

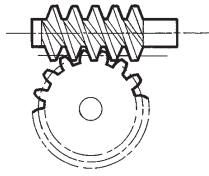

Rack and pinion

$$J = Mr^2 + \frac{mr^2}{2}$$

M = Mass to be moved
 m = Mass of pinion

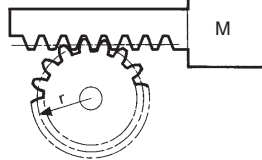

Threaded screw system

$$J = \frac{MP^2}{4\pi^2} + \frac{mr^2}{2}$$

M = Mass to be moved
 m = Mass of the screw
 r = Average radius of screw

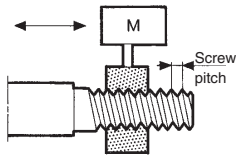

Transmission by belt (or chain)

$$J = \frac{M_1 + 2m + M_2}{2} R_1^2$$

M_1 = Mass of motor pulley
 M_2 = Mass of drawn pulley

m = Mass of belt

If the drawn pulley also receives the inertia moment J_c of a load then :

$$J = \frac{M_1 + 2m + M_2}{2} R_1^2 + J_c \left(\frac{R_1}{R_2} \right)^2$$

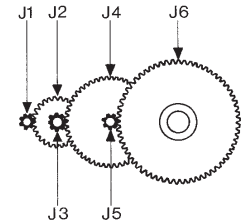
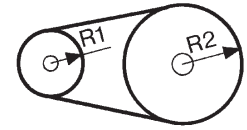

Example of a gearbox

$$J = \frac{1}{R^2} J_c + J_r$$

J_c = Load inertia carried at the gearbox output shaft

J_r = Gearbox inertia

R = Gearbox ratio

→ NB:

The inertia of a gearbox is calculated stage by stage, each gearwheel being considered as a cylinder.

$$J_r = J_1 + \left(\frac{1}{R_1} \right)^2 (J_2 + J_3) + \left(\frac{1}{R_1} \right)^2 (J_4 + J_5) + \dots$$

In practice the calculation of the first two gears, even the first one only, will give a sufficient approximate value.

5

Inertia

Calculation of inertias applied to motor

→ Cylinder

$$J = \frac{mR^2}{2}$$

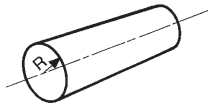

→ Wheel - Weight/pulley

$$J = mR^2$$

$$J = mR^2 + \frac{mR^2}{2}$$

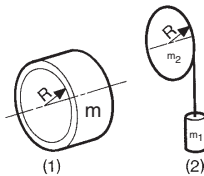

→ Coaxial cylinders (tenons)

$$J = \frac{M_1 R_1^2}{2} + \frac{M_2 R_2^2}{2}$$

M_1 = Mass of cylinder 1

M_2 = Mass of cylinder 2

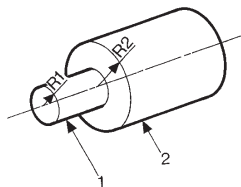

Torque conversion chart

	Nm	cm kg	cm N	m Nm	cm gr	in.oz	lb.Ft
1b.Ft	1.383	=13.83	=138.3	=1383	=13830	=192	=1
in.oz	0.00072	=0.0723	=0.723	=7.23	=72.3	=1	=0.0052
cm gr	0.0001	=0.001	=0.01	=0,1	=1	=0,0.139	=0.000723
m Nm	0.001	=0.01	=0.1	=1	=10	=0.139	=0.000723
cm N	0.01	=0.1	=1	=10	=100	=1.39	=0.00723
cm kg	0.1	=1	=10	=100	=1000	=13.9	=0.0723
Nm	1	=10<					

Moment of inertia

A \ B	kg-cm ²	g-cm ²	kg-cm-s ²	g-cm-s ²	lb-in ²	oz-in ²	lb-in-s ²	oz-in-s ²	lb-ft ²	lb ft -s ²
kg-cm ²	1	10 ³	1.01972 x10 ⁻³	1.01972	0.341716	5.46745	8.85073 x10 ⁻⁴	1.41612 x10 ²	2.37303 x10 ⁻³	7.37561 x10 ³
g-cm ²	10 ⁻³	1	1.01972 x10 ⁻⁶	1.01972 x10 ⁻³	3.41716 x10 ⁻⁴	5.46745 x10 ⁻³	8.85073 x10 ⁻⁷	1.41612 x10 ⁻⁵	2.37303 x10 ⁻⁶	7.37561 x10 ⁻⁶
kg-cm-s ²	980.665	980.665 x10 ³	1	10 ³	335.109	5.36174 x10 ³	0.867960	13.8874	2.32714	7.23300 x10 ⁻²
g-cm-s ²	0.980665	980.665	10 ⁻³	1	0.335109	5.36174 x10 ⁻⁴	8.67960 x10 ⁻⁴	1.38874 x10 ⁻²	2.32714 x10 ⁻³	7.23300 x10 ⁻⁵
lb-in ²	2.92641	2.98411 x10 ³	2.98411 x10 ⁻³	2.98411	1	16	2.59009 x10 ⁻³	4.14414 x10 ⁻²	6.94444 x10 ⁻³	2.15840 x10 ⁻⁴
oz-in ²	0.182901	182.901	1.96507 x10 ⁻⁴	0.186507	0.0625	1	1.61880 x10 ⁻⁴	2.59009 x10 ⁻³	4.34028 x10 ⁻⁴	1.34900 x10 ²
lb-in-s ²	1.12985 x10 ³	1.12985 x10 ⁶	1.15213	1.15213 x10 ³	386.088	6.17740 x10 ⁻³	1	16	2.68117	8.33333 x10 ²
oz-in-s ²	70.6157	70.6157 x10 ³	72.0079 x10 ⁻³	72.0079	24.1305	386.088	6.25 x10 ⁻²	1	0.107573	52.0833 x10
lb-ft ²	421.403	421.403 x10 ³	0.429711	429.711	144	2304	0.372972	5.96756	1	3.10810 x10 ²
lb ft -s ²	1.35582 x10 ⁴	1.35582 x10 ⁷	13.8255	1.38255 x10 ⁴	4.63305 x10 ³	7.41289 x10 ⁴	12	192	32.1740	1

Conversion tables

g	ounces	kg	lbs	cmkg	in/ lbs	cmg	in/oz	
7.1	1/4	0.008	0.23	1/2	1.10	1.152	1	0.013
14.2	1/2	0.017	0.45	1	2.20	2.304	2	0.026
21.3	3/4	0.025	0.91	2	4.41	3.456	3	0.039
28.3	1	0.035	1.36	3	6.61	4.608	4	0.053
42.5	1 1/2	0.053	1.81	4	8.82	5.760	5	0.069
56.7	2	0.070	2.27	5	11.0	6.912	6	0.078
70.9	2 1/2	0.087	2.72	6	13.2	8.064	7	0.091
85.0	3	0.106	3.18	7	15.4	9.216	8	0.106
113.0	4	0.141	3.63	8	17.6	10.368	9	0.120
142.0	5	0.176	4.08	9	19.8	11.520	10	0.139
170.0	6	0.212	4.54	10	22.0		11	0.212
198.0	7	0.247	4.99	11	24.2		12	0.278
227.0	8	0.282	5.44	12	26.4		13	0.416
255.0	9	0.318	5.90	13	28.6		14	0.555
283.0	10	0.353	6.35	14	30.8		15	0.694
312.0	11	0.388	6.80	15	33.1		16	
340.0	12	0.424	7.26	16	35.2			
368.0	13	0.459						
397.0	14	0.494						
425.0	15	0.53						
454.0	16	0.564						

Direct drive stepper motors

→ 15° 5 Watts

- 24 steps/revolution (15°)
- Absorbed power : 5 W
- 2 or 4 phase versions available



Specifications

	2 phases	4 phases
Type	82 910 5	82 910 5
Number of phases	2	4
Part numbers	82 910 501	82 910 502
General characteristics		
Electronic controller used	Bipolar	Unipolar
Resistance per phase (Ω)	12.9	115
Inductance per phase (mH)	17.3	62
Current per phase (A)	0.44	0.14
Holding torque (mN.m)	20	15
Voltage at motor terminals (V)	5.6	17
Absorbed power (W)	5	5
Step angle (°)	15	15
Positioning accuracy (mm)	5	5
Inertia of rotor (gcm ²)	4.9	4.9
Max. detent torque (mN.m)	3	3
Max. coil temperature (°C)	120	120
Storage temperature (°C)	-40 → +80	-40 → +80
Thermal resistance of coil - ambient air (°C/W)	14	14
Insulation resistance (at 500 Vcc) (MΩ) following NFC 51200 standard	> 10 ⁹	> 10 ⁹
Bearings	Sintered bronze	Sintered bronze
Insulation voltage (50 Hz, 1 minute) (V) following NFC 51200 standard	> 600	> 600
Wires length (mm)	250	250
Weight (g)	90	90
Protection rating	IP40	IP 40

Product adaptations

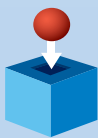

- Special output shafts
- Special supply voltages
- Special cable lengths
- Special connectors

5

To order, see page 13

Curves

Nominal value dynamic curves
2 phases - 12.9 Ω

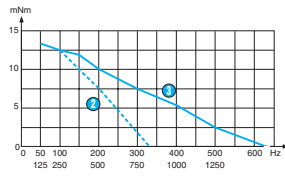

- 1 RPM
- 2 Stopping-starting
- 3 Max. operating curves

Measurement conditions :
L 297 298 SGS constant voltage
supply board, 5.6 V at motor
terminals,
2 phases energised, full steps,
inertia of measuring system 4.53
g.cm²

Nominal value dynamic curves
4 phases - 115 Ω

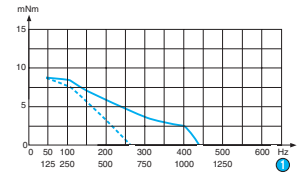

- 1 RPM
- 2 Stopping-starting
- 3 Max. operating curves

Measurement conditions :
L 297 298 SGS constant voltage
supply board, 5.6 V at motor
terminals,
2 phases energised, full steps,
inertia of measuring system 4.53
g.cm²

Dimensions

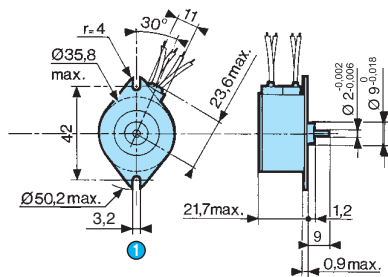

- 1 2 fixing holes Ø 3.2 ^{+0.1}0

Connections

2 phases

	1	2	3	4
1	-	+	-	+
2	-	+	+	-
3	+	-	+	-
4	+	-	-	+
5	-	+	-	+



- 1 Step
Energisation sequence for clockwise
rotation (viewed from shaft end)

4 phases

	1	2	3	4
1	-	-	-	-
2	-	-	-	-
3	-	-	-	-
4	-	-	-	-
5	-	-	-	-

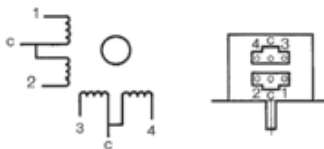

- 1 Step
Energisation sequence for clockwise
rotation : 2 phases energised (viewed from
shaft end, front forward)
Commons connected to positive.

Direct drive stepper motors

→ 7.5° 5 Watts

- 48 steps/revolution (7.5°)
- Absorbed power : 5 W
- 2 or 4 phase versions available



Specifications

	2 phases	2 phases	2 phases
Type	82 910 0	82 910 0	82 910 0
Electronic controller used	Bipolar	Bipolar	Bipolar
Bearings	Sintered bronze	Sintered bronze	Sintered bronze
Part numbers	82 910 001	●	●
General characteristics			
Resistance per phase (Ω)	9	9	9
Inductance per phase (mH)	12	12	12
Current per phase (A)	0.52	0.52	0.52
Holding torque (mN.m)	25	25	25
Voltage at motor terminals (V)	4.7	4.7	4.7
Absorbed power (W)	5	5	5
Step angle (°)	7.5	7.5	7.5
Positioning accuracy (mm)	5	5	5
Inertia of rotor (gcm ²)	4.9	4.9	4.9
Max. detent torque (mN.m)	3	3	3
Max. coil temperature (°C)	120	120	120
Storage temperature (°C)	-40 → +80	-40 → +80	-40 → +80
Thermal resistance of coil - ambient air (°C/W)	14	14	14
Insulation resistance (at 500 Vcc) (MΩ) following NFC 51200 standard	> 10 ⁹	> 10 ⁹	> 10 ⁹
Insulation voltage (50 Hz, 1 minute) (V) following NFC 51200 standard	> 600	> 600	> 600
Wires length (mm)	250	250	250
Weight (g)	90	90	90
Protection rating	IP 40	IP 40	IP 40

Product adaptations

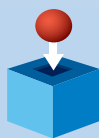

- Special output shafts
- Special supply voltages
- Special cable lengths
- Special connectors

5

To order, see page 13

Curves

Inertia of measuring chain : 1.5 g.cm²

a = constant voltage controller with R_s (resistance in series) = 0

b = constant voltage controller with R_s (resistance in series) = R motor

c = constant voltage controller with R_s (resistance in series) = 2R motor

d = constant voltage controller with R_s (resistance in series) = 3R motor

The measurements are made with full stepping, 2-phases energised.

2 phases

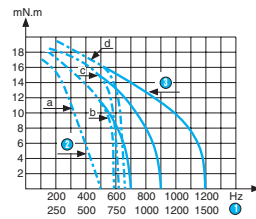

- ① RPM
- ② Max. stopping-starting curves
- ③ Max. operating curves

Max. stopping-starting and operating curves at I constant (PBL 3717) for 2 (motor) phases 12.9 Ω

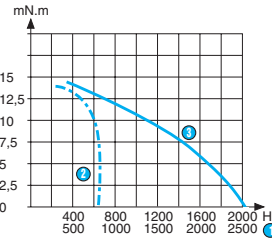

- ① RPM
- ② Max. stopping-starting curves
- ③ Max. operating curves

Max. stopping-starting frequency curves as a function of the external inertia load at zero antagonistic torque. Tests at constant U

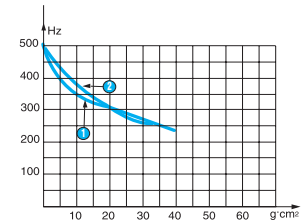

- ① 2 phases
- ② 4 phases

Dimensions

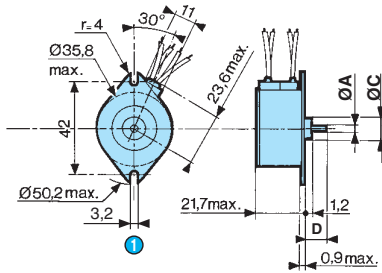

- ① 2 fixing holes Ø 3.2

Axe version	Ø A	Ø C	D
Version 1	2 ^{-0.002} _{-0.006}	9 ^{-0.010} _{-0.060}	9
Version 2	2 ^{-0.002} _{-0.006}	10 ^{-0.010} _{-0.060}	9
Version 3	3,17 ⁰ _{-0.006}	9,52 ^{-0.010} _{-0.060}	9

5

Connections

2 phases

	1	2	3	4
① 1	-	+	-	+
2	-	+	+	-
3	+	-	+	-
4	+	-	-	+
5	-	+	-	+



- ① Step
Energisation sequence for clockwise rotation (viewed shaft end)

Direct drive stepper motors

→ 7.5° 5 Watts

- 48 steps/revolution (7.5°)
- Absorbed power : 5 W
- 2 or 4 phase versions available



Specifications

	4 phases	4 phases	4 phases
Type	82 910 0	82 910 0	82 910 0
Electronic controller used	Unipolar	Unipolar	Unipolar
Bearings			
Sintered bronze	●	●	●
Plastic	●	●	●
General characteristics			
Electronic controller used	Unipolar	Unipolar	Unipolar
Resistance per phase (Ω)	15.5	15.5	15.5
Inductance per phase (mH)	8	8	8
Current per phase (A)	0.4	0.4	0.4
Holding torque (mN.m)	20	20	20
Voltage at motor terminals (V)	6.2	6.2	6.2
Absorbed power (W)	5	5	5
Step angle (°)	7.5	7.5	7.5
Positioning accuracy (mm)	5	5	5
Inertia of rotor (gcm ²)	4.9	4.9	4.9
Max. detent torque (mN.m)	3	3	3
Max. coil temperature (°C)	120	120	120
Storage temperature (°C)	-40 → +80	-40 → +80	-40 → +80
Thermal resistance of coil - ambient air (°C/W)	14	14	14
Insulation resistance (at 500 Vcc) (MΩ) following NFC 51200 standard	> 10 ³	> 10 ³	> 10 ³
Insulation voltage (50 Hz, 1 minute) (V) following NFC 51200 standard	> 600	> 600	> 600
Wires length (mm)	250	250	250
Weight (g)	90	90	90
Protection rating	IP 40	IP 40	IP 40

Product adaptations

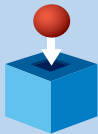

- Special output shafts
- Special supply voltages
- Special cable lengths
- Special connectors

To order, see page 13

Curves

Inertia of measuring chain : 1.5 g.cm²

a = constant voltage controller with Rs (resistance in series) = 0

b = constant voltage controller with Rs (resistance in series) = R motor

c = constant voltage controller with Rs (resistance in series) = 2R motor

d = constant voltage controller with Rs (resistance in series) = 3R motor

The measurements are made with full stepping, 2-phases energised.

4 phases

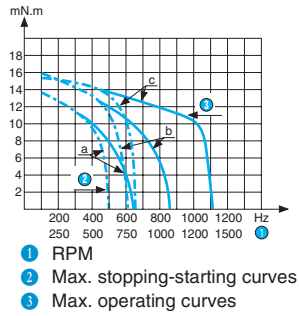

Max. stopping-starting frequency curves as a function of the external inertia load at zero antagonistic torque. Tests at constant U.

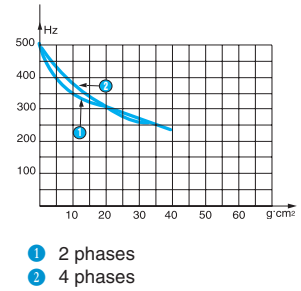

Dimensions

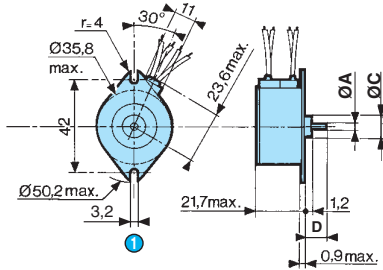

1 2 fixing holes Ø 3.2

Axe version	Ø A	Ø C	D
Version 1	2 -0,002 -0,006	9 -0,010 -0,060	9
Version 2	2 -0,002 -0,006	10 -0,010 -0,060	9
Version 3	3,17 0 -0,006	9,52 -0,010 -0,060	9

Connections

4 phases

	1	2	3	4
1	-	-	-	-
2	-	-	-	-
3	-	-	-	-
4	-	-	-	-
5	-	-	-	-

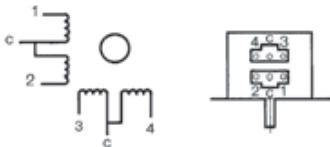

1 Step

Energisation sequence for clockwise rotation : 2 phases energised (viewed from shaft end, front forward).

Commons connected to positive.

Direct drive stepper motors

→ 7.5° 7.5 Watts

- 48 steps/revolution (7.5°)
- Absorbed power : 7.5 W
- 2 or 4 phase versions available



Specifications

			2 phases	4 phases
Type			82 920 0	82 920 0
Number of phases			2	4
Electronic controller used			Bipolar	Unipolar
Resistance per phase (Ω)	Current per phase (A)	Voltage at motor terminals (V)		
10.7	0.59	0.59	82 920 001	82 920 012
46	0.28	12.9		
General characteristics				
Absorbed power (W)			7.5	7.5
Holding torque (mN.m)			70	57
Step angle (°)			7.5	7.5
Positioning accuracy (mm)			5	5
Inertia of rotor (gcm ²)			18.8	18.8
Max. detent torque (mN.m)			6	6
Max. coil temperature (°C)			120	120
Storage temperature (°C)			-40 → +80	-40 → +80
Thermal resistance of coil - ambient air (°C/W)			9.3	9.3
Insulation resistance (at 500 Vcc) (MΩ) following NFC 51200 standard			> 10 ⁹	> 10 ⁹
Insulation voltage (50 Hz, 1 minute) (V) following NFC 51200 standard			> 600	> 600
Wires length (mm)			250	250
Weight (g)			210	210
Protection rating			IP40	IP 40

5

Product adaptations

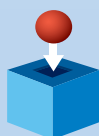

- Special output shafts
- Special supply voltages
- Special cable lengths
- Special connectors

To order, see page 13

Curves

2 phases

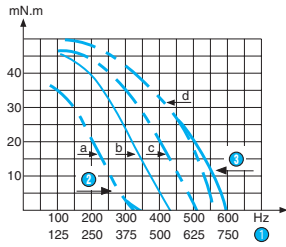

- 1 RPM
- 2 Max. stopping-starting curves
- 3 Max. operating curves

4 phases

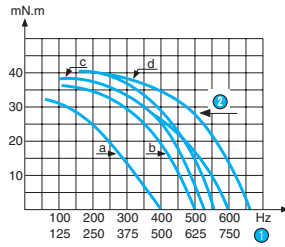

- 1 RPM
- 2 Max. operating curves

2 phases - Max. stopping-starting and operating curves at I constant (PBL 3717) for 2 (motor) phases 10.7 Ω. Holding torque 70 mN.m. Current per phase 0.59 A

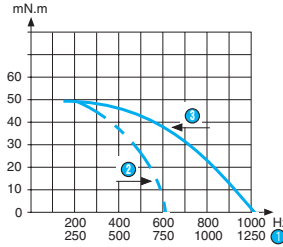

- 1 RPM
- 2 Max. stopping-starting curves
- 3 Max. operating curves

Max. stopping-starting frequency curves as a function of the external inertia load at zero antagonistic torque. Tests at constant U.

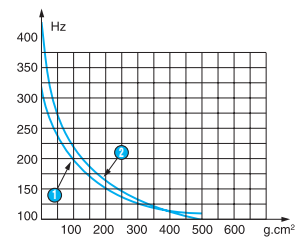

- 1 2 phases
- 2 4 phases

Inertia of measuring chain : 2.2 g.cm²

- a = constant voltage controller with Rs (resistance in series) = 0
- b = constant voltage controller with Rs (resistance in series) = R motor
- c = constant voltage controller with Rs (resistance in series) = 2R motor
- d = constant voltage controller with Rs (resistance in series) = 3R motor

The measurements are made with full stepping, 2-phases energised.

Dimensions

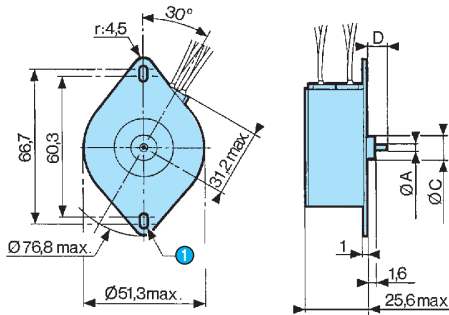

- 1 2 oblong fixing holes : wide 3.5

Version axe	Ø A	Ø C	D
Version 1	2 ⁰ _{-0,006}	9 ^{-0,010} _{-0,060}	9
Version 2	2 ⁰ _{-0,006}	10 ^{-0,010} _{-0,060}	9
Version 3	3,17 ⁰ _{-0,006}	9,52 ^{-0,010} _{-0,060}	9

5

Connections

2 phases

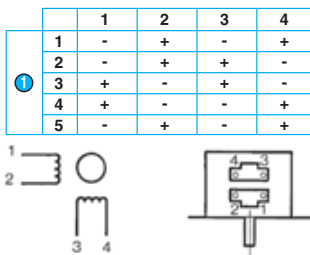

- 1 Step
Energisation sequence for clockwise rotation : (viewed shaft end)

4 phases

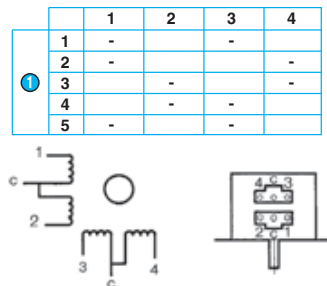

- 1 Step
Energisation sequence for clockwise rotation :
2 phases energised (viewed shaft end, front forward)
Commons connected to positive.

Direct drive stepper motors

→ 7.5° 10 Watts

- 48 steps/revolution (7.5°)
- Absorbed power : 10 W
- 2 or 4 phase versions available



Specifications

	2 phases	4 phases
Type	82 930 0	82 930 0
Number of phases	2	4
Electronic controller used	Bipolar	Unipolar
Resistance per phase (Ω)		
9	0,75	6,6
22,3	0,48	10,4
7,4	0,81	6
32	0,39	12,5
General characteristics		
Absorbed power (W)	10	10
Holding torque (mN.m)	180	155
Step angle (°)	7.5	7.5
Positioning accuracy (mm)	5	5
Inertia of rotor (gcm ²)	84	84
Max. detent torque (mN.m)	12	12
Max. coil temperature (°C)	120	120
Storage temperature (°C)	-40 → +80	-40 → +80
Thermal resistance of coil - ambient air (°C/W)	7	7
Insulation resistance (at 500 Vcc) (MΩ) following NFC 51200 standard	> 10 ⁹	> 10 ⁹
Insulation voltage (50 Hz, 1 minute) (V) following NFC 51200 standard	> 600	> 600
Wires length (mm)	250	250
Weight (g)	340	340
Protection rating	IP40	IP 40

Product adaptations

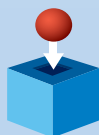

- Special output shafts
- Special supply voltages
- Special cable lengths
- Special connectors

5

To order, see page 13

Curves

2 phases

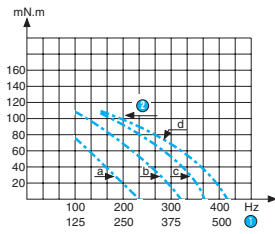

- 1 RPM
- 2 Max. stopping-starting curves

4 phases

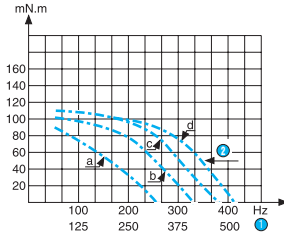

- 1 RPM
- 2 Max. stopping-starting curves

2 phases - Max. stopping-starting and operating curves at I constant (PBL 3717) for 2 (motor) phases 9 Ω. Holding torque 150 mN.m. Current per phase 0.53 A

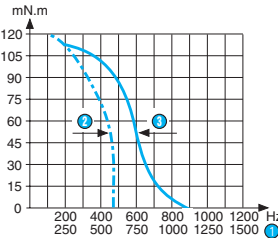

- 1 RPM
- 2 Max. stopping-starting curves
- 3 Max. operating curves

Max. stopping-starting frequency curves as a function of the external inertia load at zero antagonistic torque. Tests at constant U.

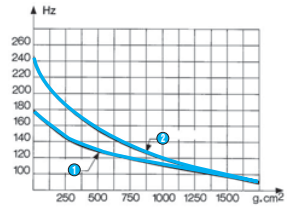

- 1 2 phases
- 2 4 phases

Inertia of measuring chain : 3.4 g.cm²

- a = constant voltage controller with R_s (resistance in series) = 0
- b = constant voltage controller with R_s (resistance in series) = R motor
- c = constant voltage controller with R_s (resistance in series) = 2R motor
- d = constant voltage controller with R_s (resistance in series) = 3R motor

The measurements are made with full stepping, 2-phases energised.

Dimensions

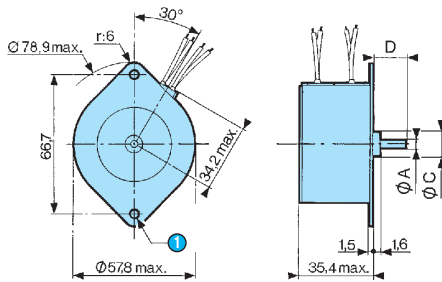

- 1 2 Fixing holes Ø 4.4

Axe version	Ø A	Ø C	D
Version 1	4 ⁰ _{-0,008}	12 ⁰ _{-0,05}	16
Version 2	6,35 ⁰ _{-0,01}	11,13 ⁰ _{-0,05}	16
Version 3	6,35 ⁰ _{-0,01}	12,7 ⁰ _{-0,05}	16

5

Connections

2 phases

	1	2	3	4
1	-	+	-	+
2	-	+	+	-
3	+	-	+	-
4	+	-	-	+
5	-	+	-	+



- 1 Step
- Energisation sequence for clockwise rotation : (viewed shaft end)

4 phases

	1	2	3	4
1	-	-	-	-
2	-	-	-	-
3	-	-	-	-
4	-	-	-	-
5	-	-	-	-

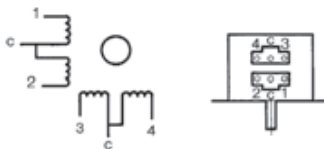

- 1 Step
- Energisation sequence for clockwise rotation : 2 phases energised (viewed shaft end, front forward)
Commons connected to positive.

Direct drive stepper motors

→ 7.5° 12.5 Watts

- 48 steps/revolution (7.5°)
- Absorbed power : 12.5 W
- 2 or 4 phase versions available



Specifications

	2 phases	4 phases
Type	82 940 0	82 940 0
Number of phases	2	4
Electronic controller used	Bipolar	Unipolar
Resistance per phase (Ω)		
5,2	1,1	5,7
26,7	0,48	12,7
7,4	0,9	6,7
26,7	0,48	12,7
General characteristics		
Absorbed power (W)	12.5	12.5
Holding torque (mN.m)	300	240
Step angle (°)	7.5	7.5
Positioning accuracy (mm)	5	5
Inertia of rotor (gcm ²)	180	180
Max. detent torque (mN.m)	16	16
Max. coil temperature (°C)	120	120
Storage temperature (°C)	-40 → +80	-40 → +80
Thermal resistance of coil - ambient air (°C/W)	5.6	5.6
Insulation resistance (at 500 Vcc) (MΩ) following NFC 51200 standard	> 10 ⁹	> 10 ⁹
Insulation voltage (50 Hz, 1 minute) (V) following NFC 51200 standard	> 600	> 600
Wires length (mm)	250	250
Weight (g)	540	540
Protection rating	IP40	IP 40

Product adaptations

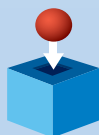

- Special output shafts
- Special supply voltages
- Special cable lengths
- Special connectors

5

To order, see page 13

Curves

2 phases

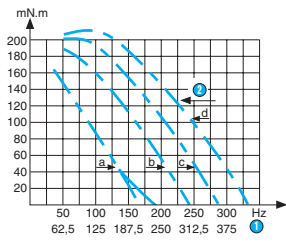

- 1 RPM
- 2 Max. stopping-starting curves

4 phases

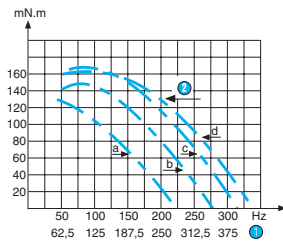

- 1 RPM
- 2 Max. stopping-starting curves

2 phases - Max. stopping-starting and operating curves at I constant (PBL 3717) for 2 (motor) phases 5.2 Ω. Holding torque 240 mN.m. Current per phase 0.55 A

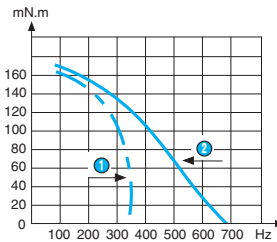

- 1 Max. stopping-starting curves
- 2 Max. operating curves

Max. stopping-starting frequency curves as a function of the external inertia load at zero antagonistic torque. Tests at constant U.

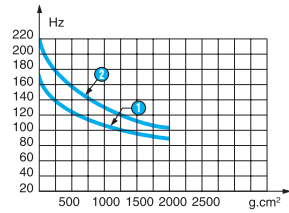

- 1 2 phases
- 2 4 phases

Inertia of measuring chain : 20.5 g.cm²

a = constant voltage controller with R_s (resistance in series) = 0

b = constant voltage controller with R_s (resistance in series) = R motor

c = constant voltage controller with R_s (resistance in series) = 2R motor

d = constant voltage controller with R_s (resistance in series) = 3R motor

The measurements are made with full stepping, 2-phases energised.

Dimensions

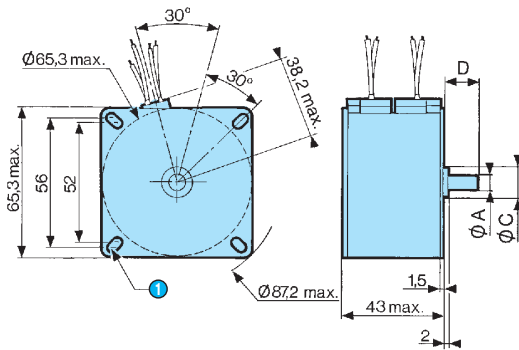

- 1 4 oblong fixing holes 4.2 wide

Axe version	Ø A	Ø C	D
Version 1	6 ⁰ _{-0,008}	12 ⁰ _{-0,05}	15
Version 2	6,35 ⁰ _{-0,01}	12,7 ⁰ _{-0,05}	15
Version 3	6,35 ⁰ _{-0,01}	14 ⁰ _{-0,05}	15

5

Connections

2 phases

	1	2	3	4
1	-	+	-	+
2	-	+	+	-
3	+	-	+	-
4	+	-	-	+
5	-	+	-	+



- 1 Step
- Energisation sequence for clockwise rotation : (viewed shaft end)

4 phases

	1	2	3	4
1	-	-	-	-
2	-	-	-	-
3	-	-	-	-
4	-	-	-	-
5	-	-	-	-

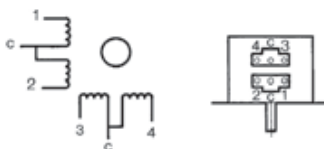

- 1 Step
- Energisation sequence for clockwise rotation : 2 phases energised (viewed shaft end, front forward)
Commons connected to positive.

Geared stepper motors

→ 0.5 Nm 5 and 7.5 Watts



Specifications

	7.5 Watts	7.5 Watts	5 Watts	5 Watts
Type	82 924 0	82 924 0	82 914 5	82 914 0
Number of phases	2	4	2 / 4	2 / 4
Ratios				
10	82 924 020	82 924 028	•	•
20	82 924 022	82 924 030	•	•
25	•	•	•	•
50	•	•	•	•
100	•	•	•	•
250	•	•	•	•
500	•	•	-	-
General characteristics				
Stepper motor / Number of phases	82 920 001 / 2	82 920 012 / 4	82 910 501 / 2 82 910 502 / 4	82 910 001 / 2 82 910 008 / 4
Gearbox	81 021	81 021	81 021	81 021
Step angle (°)				
Maximum permitted torque from gearmotor under continuous conditions (N.m)	0.5	0.5	0.5	0.5
Axial load static (daN)	1	1	1	1
Radial load static (daN)	8	8	8	8
Absorbed power (W)	7.5	7.5	5	5
Coil temperature (°C)	120	120	120	120
Weight (g)	140	140	140	140
Wires length (mm)	250	250	250	250
Protection rating	IP40	IP40	IP40	IP40

Product adaptations

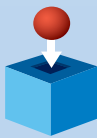

- Special output shafts
- Special supply voltages
- Special cable lengths
- Special output bearings
- Special connectors
- Special gearbox ratios
- Special mounting plate
- Special gear wheel material

Dimensions

82 924 0

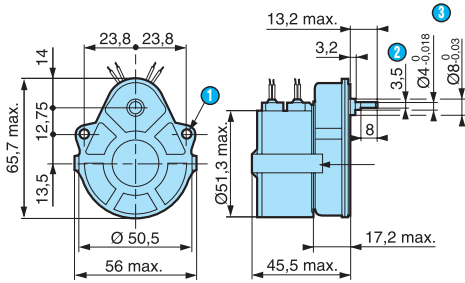

- ① 2 fixing holes \varnothing 3.2
- ② 3.5 across flat
- ③ (pushed-in shaft \leftarrow)

82 914 0 - 82 914 5

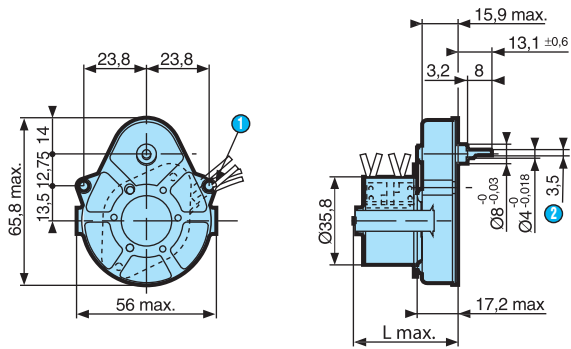

- ① 2 fixing holes \varnothing 3.2
- ② 3.5 across flat

82 914 0 = L max. 39.5
82 914 5 = L max. 42.7

Options

Optional shafts for 81 021
79 200 967

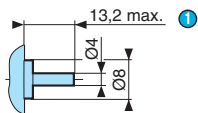

- ① (Pushed-in shaft \leftarrow)

79 200 779

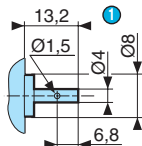

- ① (Pushed-in shaft \leftarrow)

70 999 421
SP 1295-10

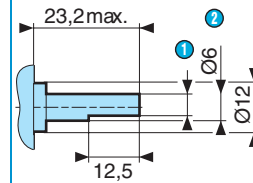

- ① (Pushed-in shaft \leftarrow)
- ② 5 across flat

Geared stepper motors

→ 2 Nm 5 and 7.5 Watts



Specifications

	7.5 Watts	5 Watts	5 Watts
Type	82 929 0	82 919 5	82 919 0
Number of phases	2 / 4	2 / 4	2 / 4
Ratios			
25	•	•	•
50	•	•	•
100	•	•	•
250	•	•	•
General characteristics			
Stepper motor / Number of phases	82 920 001 / 2 82 920 012 / 4	82 910 501 / 2 82 910 502 / 4	82 910 001 / 2 82 910 008 / 4
Gearbox	81 033	81 033	81 033
Step angle (°)	7.5	15	7.5
Maximum permitted torque from gearmotor under continuous conditions (N.m)	2	2	2
Axial load static (daN)	1	1	1
Radial load static (daN)	10	10	10
Absorbed power (W)	7.5	5	5
Coil temperature (°C)	120	120	120
Weight (g)	260	140	230
Wires length (mm)	250	250	250
Protection rating	IP 40	IP 40	IP 40

5

Product adaptations

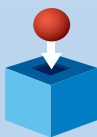

- Special output shafts
- Special supply voltages
- Special cable lengths
- Special output bearings
- Special connectors
- Special gearbox ratios
- Special mounting plate
- Special gear wheel material

To order, see page 13

Dimensions

82 929 0

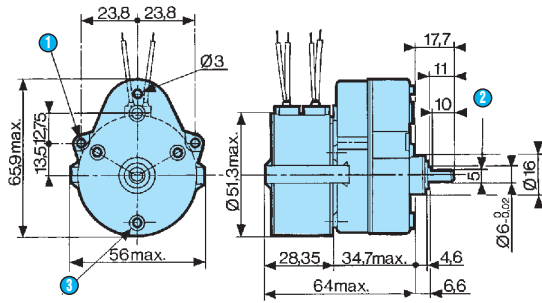

- 1 2 fixing holes $\varnothing 3.2$
- 2 5 across flat
- 3 3 mounting bosses $\varnothing 6.8$ at 120° on radius = 19.5
3 holes M3 depth 4.5

70 999 421
SP 1295-10

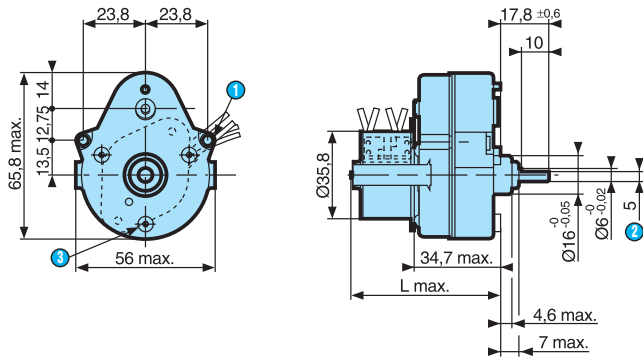

- 1 2 fixing holes $\varnothing 3.2$
- 2 5 across flat
- 3 3 mounting bosses $\varnothing 6.8$ at 120° on radius = 19.5 3 holes M3 depth 4.5

82 919 0 = L max. 58.5
82 919 5 = L max. 60.2

Options

70 999 421 SP 1295-10

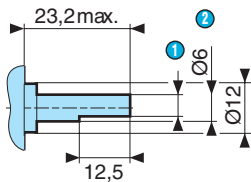

- 1 (pushed-in shaft ←)
- 2 5 across flat

Geared stepper motors

→ 3 Nm 2.5 and 3.5 Watts

- Mechanical strength 3 Nm
- 2 and 4 phases



Specifications

	2.5 Watts	2.5 Watts	3.5 Watts	3.5 Watts
Type	80 913 0	80 913 5	80 923 0	80 933 0
Ratios				
150	●	●	●	●
187.5	●	●	●	●
300	●	●	●	●
375	●	●	●	●
600	●	●	●	●
750	●	●	●	●
1200	●	●	●	●
2250	●	●	●	●
2400	●	●	●	●
3600	●	●	●	●
General characteristics				
Motor	82 910 0	82 910 5	82 920	82 930
Gearbox	81 023 0	81 023 0	81 023 0	81 023 0
Maximum permitted torque from gearmotor under continuous conditions (N.m)	3	3	3	3
Axial load static (daN)	2	2	2	2
Radial load static (daN)	3	3	3	3
Absorbed power (W)	2.5	2.5	3.5	3.6
Weight (g)	370	370	490	620
Wires length (mm)	250	250	250	250
Protection rating	IP00	IP00	IP00	IP00

Product adaptations

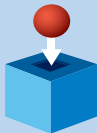

- Special output shafts
- Special cable lengths
- Special output bearings
- Special connectors
- Special gearbox ratios

5

To order, see page 13

Dimensions

80 913 0/5

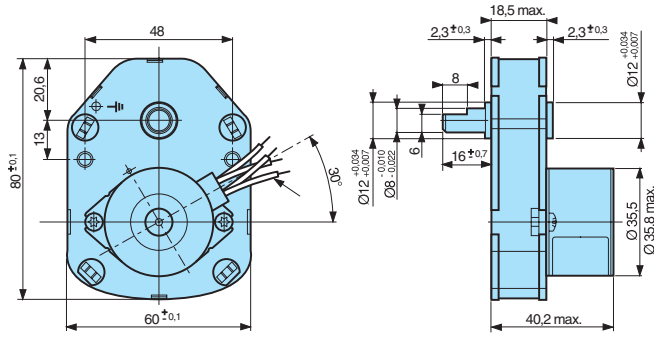

80 923 0

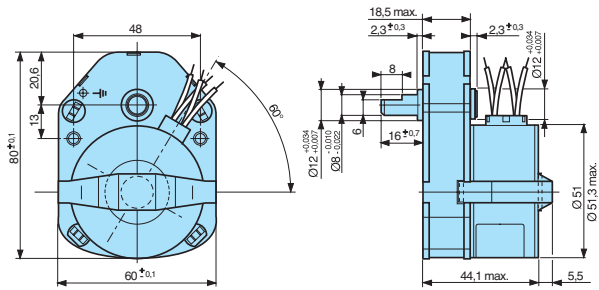

80 933 0

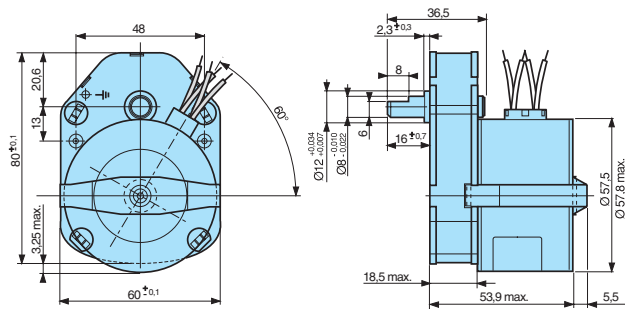

Geared stepper motors

→ 5 Nm 5 and 7.5 Watts

- Mechanical strength : 5 Nm
- 2 and 4 phases



Specifications

	5 Watts	7.5 Watts	7.5 Watts
Type	80 917 0	80 927 0	80 927 0
Number of phases	2 / 4	2	4
Ratios			
12.5	●	80 927 019	80 927 020
25	●	●	●
31.25	●	●	●
41.66	●	●	●
62.5	●	●	●
83.33	●	●	●
125	●	●	●
250	●	80 927 006	●
500	●	●	●
750	●	●	●
2500	●	●	●
General characteristics			
Motor	82 910 0	82 920 001	82 920 012
Gearbox	81 037	81 037	81 037
Maximum permitted torque from gearmotor under continuous conditions (N.m)	5	5	5
Number of phases	2/4	2	4
Axial load static (daN)	2	2	2
Radial load static (daN)	3	3	3
Absorbed power (W)	5	7.5	7.5
Coil temperature (°C)	120	120	120
Weight (g)	410	530	530
Wires length (mm)	250	250	250
Protection rating	IP 40	IP 40	IP 40

5

Product adaptations

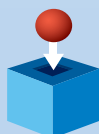

- Special output shafts
- Special cable lengths
- Special output bearings
- Special connectors
- Special gearbox ratios
- Special gear wheel material

To order, see page 13

Dimensions

80 917 0 - 80 927 0

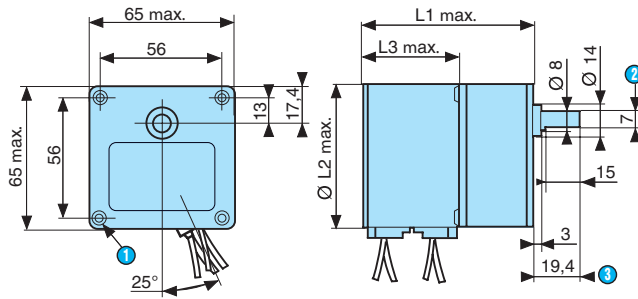

- ① 4 holes M4 depth 12
- ② across flat
- ③ (pushed-in shaft ←)

80 917 0 = L1 : 58.5 mm - ØL2 : 35.8 mm - L3 : 22.3 mm
80 927 0 = L1 : 59.2 mm - ØL2 : 51.3 mm - L3 : 25.6 mm

Options

Shaft 79 206 478

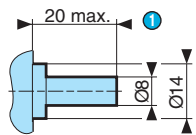

- ① (pushed-in shaft ←)

Geared stepper motors

→ 5 Nm 12.5 Watts

- Mechanical strength : 5 Nm
- 2 and 4 phases



Specifications

	12.5 Watts	12.5 Watts
Type	80 947 0	80 947 0
Number of phases	2	4
Ratios		
12.5	80 947 019	80 947 020
25	80 947 001	80 947 010
31.25	●	●
41.66	●	●
62.5	●	●
83.33	●	●
125	●	●
250	●	●
500	●	●
750	●	●
2500	●	●
General characteristics		
Motor	82 940 002	82 940 015
Gearbox	81 037	81 037
Maximum permitted torque from gearmotor under continuous conditions (N.m)	5	5
Number of phases	2	4
Axial load static (daN)	2	2
Radial load static (daN)	3	3
Absorbed power (W)	12.5	12.5
Coil temperature (°C)	120	120
Weight (g)	860	860
Wires length (mm)	250	250
Protection rating	IP 40	IP 40

Product adaptations

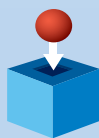

- Special output shafts
- Special cable lengths
- Special output bearings
- Special connectors
- Special gearbox ratios
- Special gear wheel material

5

To order, see page 13

Dimensions

80 947 0

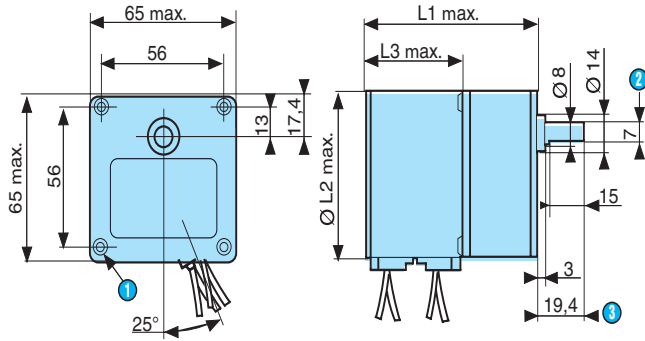

- ① 4 holes M4 depth 12
- ② across flat
- ③ (pushed-in shaft ←)

80 947 0 = L1 : 76.6 mm - ØL2 : 65.3 mm - L3 : 43 mm

Options

Shaft 79 206 478

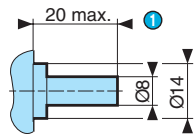

- ① (pushed-in shaft ←)

Linear motors

Linear motors

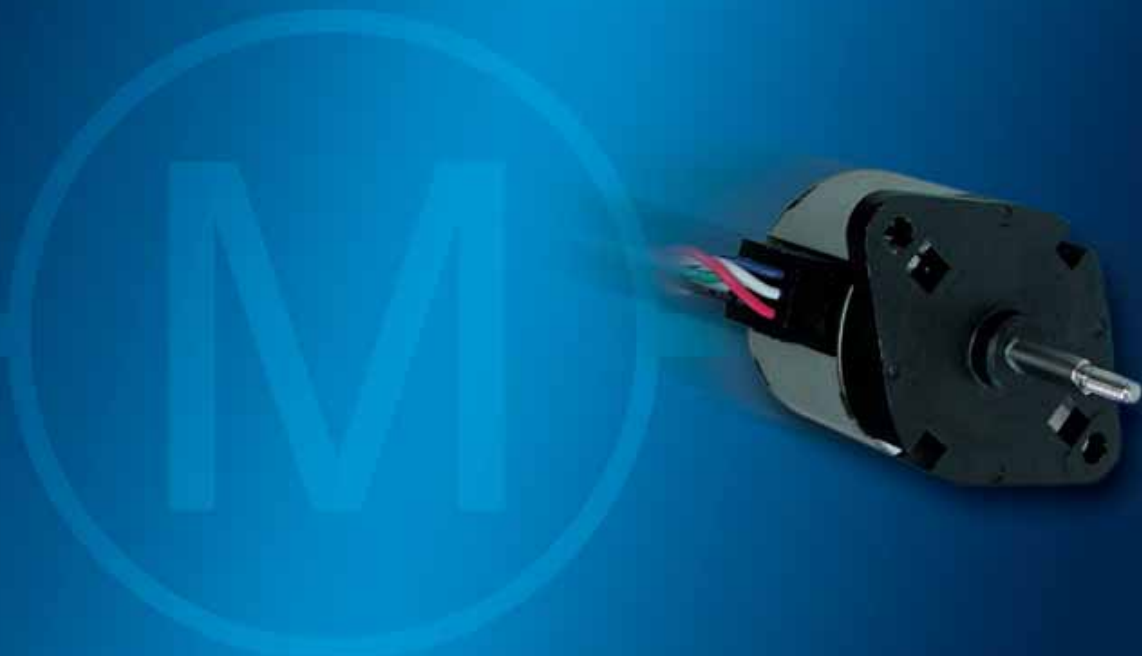
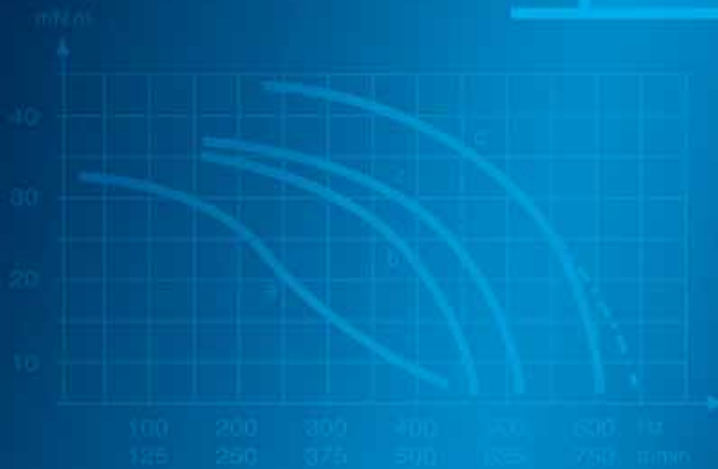
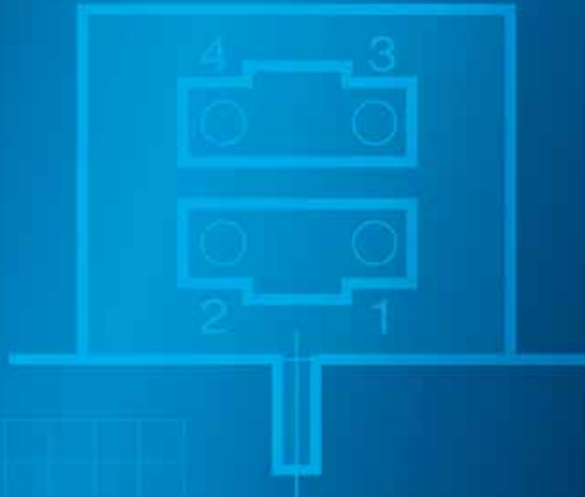

Linear actuators -synchronous

→ 10 mm displacement - 230 Volts

- A range of digital linear actuators based upon synchronous motor technology. They offer a linear travel of 10 mm as standard and up to 35 mm upon request for versions with an anti-rotation device built-in. Linear step speed 0.833 or 1.67 mm per second.
- Output force between 27 and 45 N.



Specifications

	Low speed - series connection	Low speed - parallel connection	High speed - series connection	High speed - parallel connection
Type	80 510 0	80 510 0	80 510 5	80 510 5
Voltages/Frequencies	230 V - 50 Hz	230 V - 50 Hz	230 V - 50 Hz	230 V - 50 Hz
Standard motor speed (rpm)	250	250	500	500
Part numbers	●	●	●	●
General characteristics				
Connection	Series	Series	Series	Series
Rated displacement (mm)	10	10	10	10
Vitesse de déplacement (f= 50 Hz) (mm/s)	3.33	3.33	3.33	3.33
Axial load static (daN)	10	10	10	10
Radial load	Consult us	Consult us	Consult us	Consult us
Ambient operating temperature (°C)	-5 / +75	-5 / +75	-5 / +75	-5 / +75
Wires length (mm)	250 ± 10	250 ± 10	250 ± 10	250 ± 10
Electromechanical specifications				
Dynamic axial load to 100 Hz (N)	35	35	35	35
Absorbed power (W)	2.7	2.7	2.7	2.7
Absorbed current nominal (A)	10.9 mA	10.9 mA	10.9 mA	10.9 mA
Temperature rise at T = 25°C	57°C ± 10 %	57°C ± 10 %	57°C ± 10 %	57°C ± 10 %
Life	500 000 cycles	500 000 cycles	500 000 cycles	500 000 cycles
Mounting position	Any position	Any position	Any position	Any position
Storage temperature (°C)	-40→+80	-40→+80	-40→+80	-40→+80
Weight (g)	90	90	90	90

Product adaptations

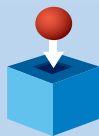

- Special output shafts
- Special supply voltages
- Special cable lengths
- Customised electronics
- Special construction materials
- Special connectors

6

To order, see page 13

Accessories

Voltages/Frequencies	μF	V	Connection	Code
Capacitors motor 80 510 0				
230 V - 50 Hz	$0.33 \pm 10 \%$	400	Serie	26 231 801
230 V - 50 Hz	$0.1 \pm 10 \%$	700	Parallel	26 231 941
115 V - 50/60 Hz	$0.27 \pm 10 \%$	250	Parallel	26 231 851
24 V - 50 Hz	$8.2 \pm 10 \%$	70	Parallel	26 231 711
24 V - 60 Hz	$6.8 \pm 10 \%$	63	Parallel	26 231 708
Capacitors motor 80 510 5				
230 V - 50 Hz	$0.33 \pm 10 \%$	400	Serie	26 231 801
230 V - 50 Hz	$0.1 \pm 10 \%$	700	Parallel	26 231 941
115 V - 50/60 Hz	$0.27 \pm 10 \%$	250	Parallel	26 231 924
24 V - 50 Hz	$8.2 \pm 10 \%$	70	Parallel	26 231 711

Dimensions

80 510 0 - 80 510 5

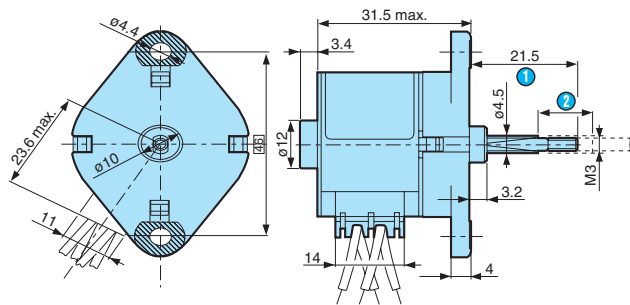

- 1 Shaft in
- 2 Travel

Connections

In series

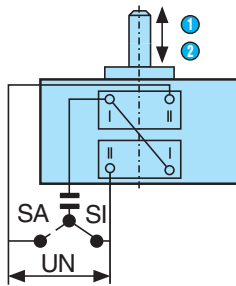

- 1 SA : Shaft out
- 2 SI : Shaft in

In parallel

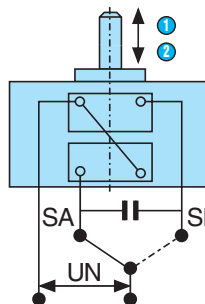

- 1 SA : Shaft out
- 2 SI : Shaft in

Other information

Electromagnetic compatibility :
 Conducted emissions : EN 55 014
 Radiated emissions : EN 55 022
 Protection index IP40 EN 60 034 / CEI 529
 Temperature limit when stalled Classe B EN 60 335-1 CEI 85

Linear actuators -stepper

→ 10 mm displacement -7.5° step angle

- A range of digital linear actuators based upon synchronous motor technology. They offer a linear travel of 10 mm as standard and up to 35 mm upon request for versions with an anti-rotation device built-in. Linear step speed 0.833 or 1.67 mm per second.
- Output force between 27 and 45 N.



Specifications

	2 phases	4 phases
Type	80 910 0	80 910 0
Nominal voltage (V)	5.6	12.7
Part numbers	●	●
General characteristics		
Motor step (°)	7.5	7.5
Number of phases	2	2
Rated displacement (mm)	10	10
Linear step displacement (mm)	0.0167	0.0167
Positioning accuracy (mm)	< 0.01	< 0.01
Axial load static (daN)	10	10
Radial load	Consult us	Consult us
Operating temperature (°C)	-5 → +75	-5 → +75
Wires length (mm)	250 ± 10	250 ± 10
Coil (Ω)	12.9	12.9
Electromechanical specifications		
Dynamic axial load to 100 Hz (N)	58	58
Absorbed power (W)	5	5
Absorbed current nominal (A)	0.44 A nominal	0.44 A nominal
Life	500 000 cycles	500 000 cycles
Mounting position	Any	Any
Storage temperature (°C)	-40 → +80	-40 → +80
Weight (g)	90	90

Product adaptations

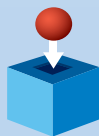

- Special output shafts
- Special supply voltages
- Special cable lengths
- Customised electronics
- Special construction materials
- Special connectors

6

To order, see page 13

Dimensions

80 910 0

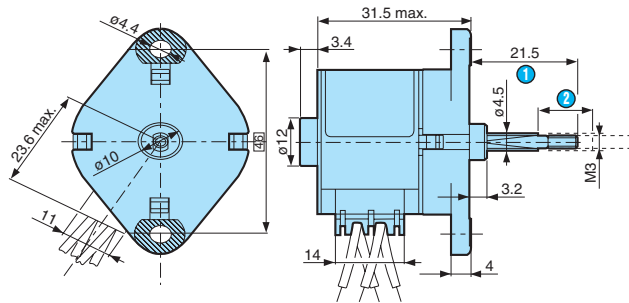

- ① Shaft in
- ② Travel

Connections

2 phases

	1	2	3	4
①	-	+	-	+
2	-	+	+	-
3	+	-	+	-
4	+	-	-	+
5	-	+	-	+



- ① Step
Energisation sequence for shaft outward movement

4 phases

	1	2	3	4
①	-	-	-	-
2	-	-	-	-
3	-	-	-	-
4	-	-	-	-
5	-	-	-	-

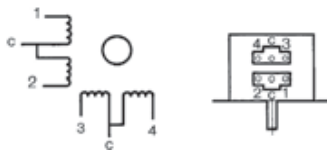

- ① Step
Energisation sequence for shaft outward movement

Other information

Electromagnetic compatibility :
 Conducted emissions : EN 55 014
 Radiated emissions : EN 55 022
 Protection index IP40 EN 60 034 / CEI 529
 Temperature limit when stalled Classe B EN 60 335-1 CEI 85

Linear actuators -stepper

→ 10 mm displacement -15° step angle

- A range of digital linear actuators based upon synchronous motor technology. They offer a linear travel of 10 mm as standard and up to 35 mm upon request for versions with an anti-rotation device built-in. Linear step speed 0.833 or 1.67 mm per second.
- Output force between 27 and 45 N.



Specifications

	2 phases	4 phases
Type	80 910 5	80 910 5
Nominal voltage (V)	5.6	17
Part numbers	●	●
General characteristics		
Motor step (°)	7.5	7.5
Number of phases	2	2
Rated displacement (mm)	10	10
Linear step displacement (mm)	0.0167	0.0167
Positioning accuracy (mm)	< 0.01	< 0.01
Axial load static (daN)	10	10
Radial load	Consult us	Consult us
Operating temperature (°C)	-5 → +75	-5 → +75
Wires length (mm)	250 ± 10	250 ± 10
Coil (Ω)	12.9	12.9
Electromechanical specifications		
Dynamic axial load to 100 Hz (N)	58	58
Absorbed power (W)	5	5
Absorbed current nominal (A)	0.44 A nominal	0.44 A nominal
Life	500 000 cycles	500 000 cycles
Mounting position	Any	Any
Storage temperature (°C)	-40 → +80	-40 → +80
Weight (g)	90	90

Product adaptations

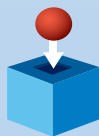

- Special output shafts
- Special supply voltages
- Special cable lengths
- Customised electronics
- Special construction materials
- Special connectors

6

To order, see page 13

Dimensions

80 910 5

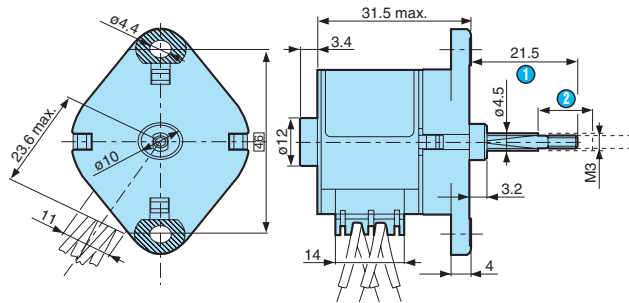

- 1 Shaft in
- 2 Travel

Connections

2 phases

	1	2	3	4
1	-	+	-	+
2	-	+	+	-
3	+	-	+	-
4	+	-	-	+
5	-	+	-	+



- 1 Step
Energisation sequence for shaft outward movement

4 phases

	1	2	3	4
1	-	-	-	-
2	-	-	-	-
3	-	-	-	-
4	-	-	-	-
5	-	-	-	-

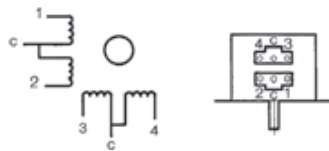

- 1 Step
Energisation sequence for shaft outward movement

Other information

Electromagnetic compatibility :
 Conducted emissions : EN 55 014
 Radiated emissions : EN 55 022
 Protection index IP40 EN 60 034 / CEI 529
 Temperature limit when stalled Classe B EN 60 335-1 CEI 85

Fans

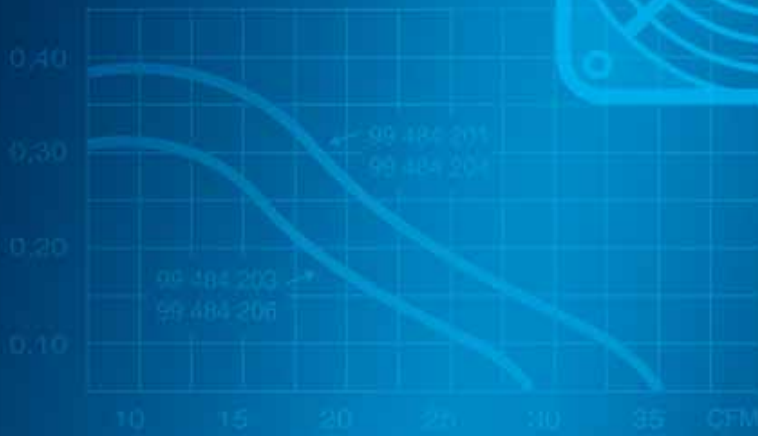

Axial fans

Noise data

Acoustic measurements made at a distance of 1.0 metre from the surface of the fan (inner side) and 45° radially off the fan axis.

Air flow performance data

The performance data were determined in accordance with AMCA standard 210-74 on a double chamber test set up with measurement on the suction side.

Overload

All Crouzet fans have integrated protection against locked rotor condition to avoid damage to windings and electronic components. Restarting is automatic as soon as any constraints on running have been removed.

Bearing systems

All Crouzet fans have specially designed and precision lubricated sleeve bearings for long, maintenance-free performance at low noise level. Ball bearing on request.

User precautions: When a fan is used in a horizontal orientation (shaft vertical), it is imperative to use a version fitted with ball bearings.

Safety

All fans are designed and manufactured in conformance with the requirements of UL, CSA and VDE.

Life

→ AC fans Bearings sleeve

☐ 120 x 38 mm	100 000 hours at 25 °C 25 000 hours at 55 °C 10 000 hours at 70 °C
☐ 92 x 25 mm 80 x 38 mm 80 x 25 mm	80 000 hours at 25 °C 20 000 hours at 55 °C 10 000 hours at 70 °C

→ AC fans Ball bearings

☐ 120 x 38 mm	100 000 hours at 25 °C 25 000 hours at 55 °C 10 000 hours at 70 °C
☐ 92 x 25 mm 80 x 38 mm 80 x 25 mm	80 000 hours at 25 °C 25 000 hours at 55 °C 10 000 hours at 80 °C

→ DC fans Bearings sleeve

☐ 120 x 38 mm	100 000 hours at 25 °C 80 000 hours at 25 °C 80 000 hours at 25 °C
☐ 60 x 25 mm	65 000 hours at 25 °C 30 000 hours at 55 °C 20 000 hours at 65 °C

Flow conversion table

	CFM	m ³ /h	m ³ /min	l/min	l/s
1 CFM	1	1.7	0.028	28.3	0.47
1 m ³ /h	0.588	1	0.017	16.67	0.28
1 m ³ /min	35.28	60	1	1000	16.67
1 l/min	0.035	0.06	0.001	1	0.017
1 l/s	2.12	3.6	0.06	60	1

The KDE range Self-commutated DC fans

The range of DC fans have the advantage of a new, patented design referred to as «single winding».

This new range, the KDE range, forms a useful replacement for the MD range and provides the following improvements:

- higher air flow thanks to smaller motor diameter,
- quieter (gain of at least 2 dB),
- longer life,
- greater dielectric strength.

The new range offers upward compatibility (1) with the MD range (see table below) and allows us to offer fans even more compact than the 0 x 0, 0 x 0, 0 x 0, and 0 x 0 models.

(1) Current consumption should be checked however, as it may be higher in some cases.

Old part no	New part no	Old part no	New part no
☐ 60		☐ 120	
99 486 177	99 484 401	99 487 477	99 484 001
99 486 179	99 484 403	99 487 478	99 484 003
99 486 179	99 484 404	99 487 479	99 484 004
☐ 80		99 487 487	99 484 005
99 486 277	99 484 301	99 487 488	99 484 007
99 486 279	99 484 303	99 487 489	99 484 008
99 486 287	99 484 304	99 487 377	99 484 101
99 489 287	99 484 354	99 487 378	99 484 102
99 486 289	99 484 306	99 487 379	99 484 103
☐ 92		99 487 387	99 484 104
99 486 377	99 484 201	99 487 388	99 484 105
99 489 377	99 484 251	99 487 389	99 484 106
99 486 379	99 484 203		
99 486 387	99 484 204		
99 486 389	99 484 206		

AC fan

→ SP - DP - SF ranges

- air flow : 17 to 115 CFM
- acoustic noise : 29 to 50 dB A



Specifications

Type	Voltage (VAC)	Current (A)	Power (W)	Locked (A)	Speed (rpm)	Noise (dB A)	Air flow rate 1 CFM = 1.7 m ³ /h (CFM)	Outputs	Code
80 x 25 mm	115	0.12/0.11	12/10	0.14/0.13	2300/2750	29/33	17/21	wire	99 486 814
	220/230	0.07/0.07	14/13.5	0.10/0.09	2300/2750	29/33	17/21	wire	99 486 804
80 x 38 mm	115	0.15/0.13	14/12	0.15/0.14	2300/2750	31/35	23/30	wire	99 486 914
	220/230	0.07/0.06	14/12	0.11/0.10	2300/2750	31/35	23/30	wire	99 486 904
92 x 25 mm	115	0.12/0.11	13/12	0.14/0.13	2250/2750	36/39	29/36	wire	99 487 114
	115	0.12/0.11	13/12	0.14/0.13	2250/2750	36/39	29/36	tags	99 487 112
	220/230	0.07/0.06	14.5/14	0.10/0.09	2250/2750	36/39	29/36	wire	99 487 104
	220/230	0.07/0.06	14.5/14	0.10/0.09	2250/2750	36/39	29/36	tags	99 487 102
	220/230	0.07/0.06	14.5/14	0.10/0.09	2350/2850	37/40	29/36	tags	99 489 102
	120 x 38 mm	115	0.21/0.18	20/18	0.23/0.21	2550/2900	43/48	85/105	wire
120 x 38 mm	115	0.21/0.18	20/18	0.23/0.21	2750/3050	45/50	87/107	wire	99 489 410
	220/230	0.12/0.11	20/19	0.14/0.12	2550/2900	43/48	85/105	wire	99 487 400
	220/230	0.12/0.11	20/19	0.14/0.12	2750/3050	45/50	87/107	wire	99 489 400
	115	0.13/0.11	11/11	0.14/0.11	2000/2200	36/38	70/76	wire	99 487 415
	115	0.13/0.11	11/11	0.14/0.11	2150/2300	37/39	72/78	wire	99 489 415
	220/230	0.08/0.06	10/10	0.10/0.08	2000/2200	36/38	70/76	wire	99 487 405
	220/230	0.08/0.06	10/10	0.10/0.08	2150/2300	37/39	72/78	wire	99 489 405
	220/240	0.14/0.12	22/21	0.16/0.14	2700/3100	44/49	95/115	Tags	99 487 420
	115	0.21/0.18	20/18	0.23/0.21	2550/2900	43/48	85/105	Tags	99 487 411
	115	0.21/0.18	20/18	0.23/0.21	2750/3050	45/50	87/107	Tags	99 489 411
	220/230	0.12/0.11	20/19	0.14/0.12	2550/2900	43/48	85/105	Tags	99 487 401
	220/230	0.12/0.11	20/19	0.14/0.12	2750/3050	45/50	87/107	Tags	99 489 401
	115	0.13/0.11	11/11	0.14/0.11	2000/2200	36/38	70/76	Tags	99 487 413
	115	0.13/0.11	11/11	0.14/0.11	2150/2300	37/39	72/78	Tags	99 489 413
	220/230	0.08/0.06	10/10	0.10/0.08	2000/2200	36/38	70/76	Tags	99 487 403
	220/230	0.08/0.06	10/10	0.10/0.08	2150/2300	37/39	72/78	Tags	99 489 403

General characteristics

Frequency (Hz)	50/60
Bearings	sleeve
Material Plastic body	aluminium
Material Fan	PBT UL 94V-0
Motor : asynchronous with dephasing rings	✓
Insulation (IEC 664-1)	Class B
Approved UL and CSA, in progress	✓
Ball bearings on request for	92 x 25 mm 80 x 38 mm 80 x 25 mm
Weight 80 x 25 mm	260 g
Weight 80 x 38 mm	340 g
Weight 92 x 25 mm	280 g
Weight 120 x 38 mm	550 g
Minimum order quantity : 80 x 25 mm	50 units Packed in 1 box
Minimum order quantity : 80 x 38 mm	50 units Packed in 1 box
Minimum order quantity : 92 x 25 mm	50 units Packed in 1 box
Minimum order quantity : 120 x 38 mm	40 units Packed in 1 box
Other types : minimum quantity	500 units

To order, see page 13

Dimensions

80 x 38 - 80 x 25

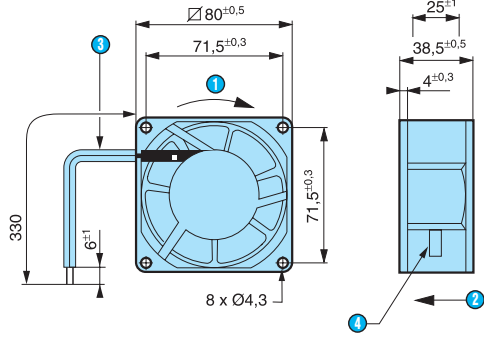

- 1 Rotation
- 2 Air flow
- 3 UL 1007 24 AWG
- 4 2 earth tags

92 x 25

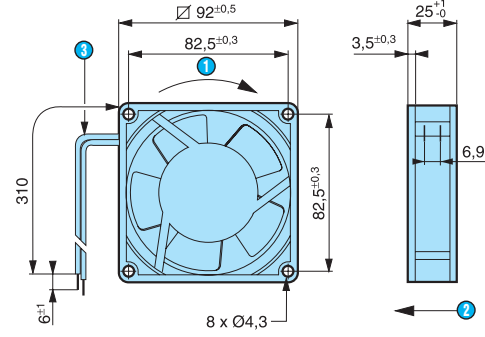

- 1 Rotation
- 2 Air flow
- 3 UL 1007 24 AWG

120 x 38

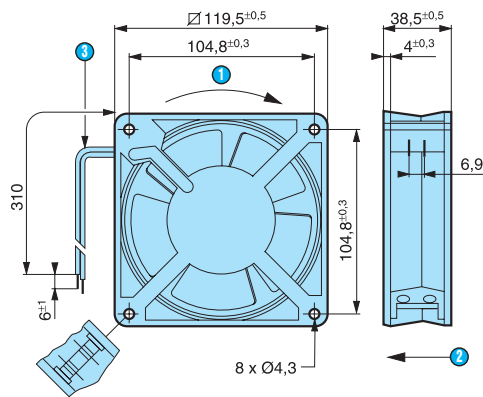

- 1 Rotation
- 2 Air flow
- 3 UL 1007 24 AWG

Air performance

99 486 814 - 99 486 804

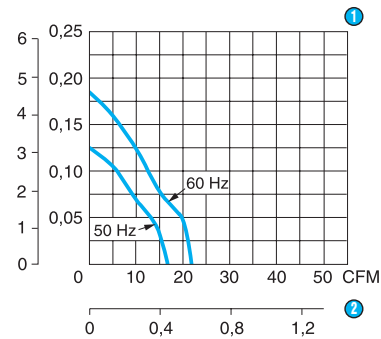

- 1 Air flow
- 2 m³/min

99 486 914 - 99 486 904

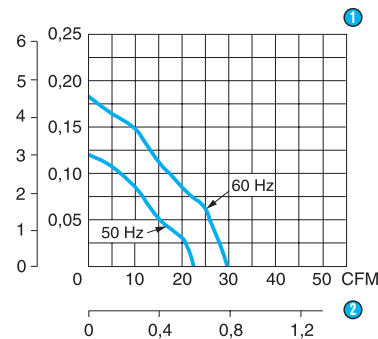

- 1 Air flow
- 2 m³/min

99 487 1

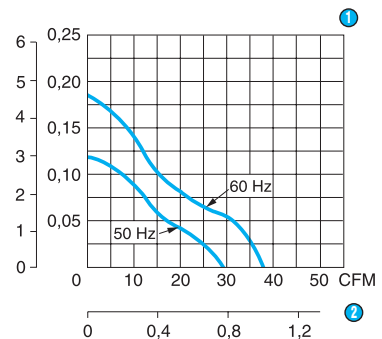

- 1 Air flow
- 2 m³/min

99 487 420

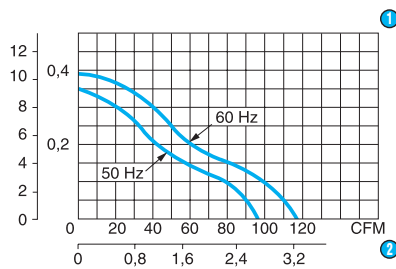

- 1 Air flow
- 2 m³/min

99 487 4 - 99 489 4

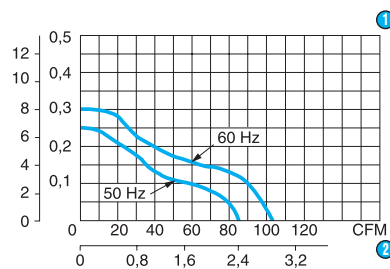

- 1 Air flow
- 2 m³/min

DC brushless fan

→ KDE range

- air flow : 1.5 to 110 CFM
- acoustic noise : 23 to 45 dB A



Specifications

Type	Voltage (V)	Nominal current (A)	nominal power (W)	Speed (rpm)	Max. air flow rate 1 CFM = 1.7 m³/h (CFM)	Code
120 x 38 mm	12	0.59	7	3000	110	99 484 002
	24	0.25	6	3000	110	99 484 006
92 x 25 mm	12	0.22	2.6	3200	50	99 484 201
	24	0.15	3.6	3200	50	99 484 204
	12	0.12	1.4	2400	42	99 484 203
	24	0.11	2.6	2400	42	99 484 206
80 x 25 mm	12	0.22	2.6	3000	41.7	99 484 301
	24	0.15	3.6	3000	41.7	99 484 304
	12	0.12	1.4	2200	29.4	99 484 303
	24	0.1	2.4	2200	29.4	99 484 306
60 x 25 mm	12	0.19	2.2	4500	21.7	99 484 401
	12	0.09	1.2	3300	15.9	99 484 403
60 x 15 mm	12	0.16	1.9	4000	17.8	99 484 501
40 x 20 mm	12	0.07	0.9	6000	6.5	99 484 601
40 x 10 mm	12	0.07	0.9	5600	5.8	99 484 701
25 x 10 mm	12	0.095	1.1	10000	1.5	99 484 801

General characteristics

Bearings	sleeve
Material Plastic body	PBT UL 94V-0
Material Fan	PBT UL 94V-0
Insulation (IEC 664-1)	Class E
Approved UL, CSA and TUV	✓
Available with ball bearings on request, in suitable quantities	✓
Weight (g) 120 x 38 mm	328
Weight (g) 92 x 25 mm	135
Weight (g) 80 x 25 mm	120
Weight (g) 60 x 25 mm	60
Weight (g) 60 x 15 mm	45
Weight (g) 40 x 20 mm	35
Weight (g) 40 x 10 mm	20
Weight (g) 25 x 10 mm	7.5
Minimum order quantity : 120 x 38 mm	40 units
Minimum order quantity : 92 x 25 mm	50 units
Minimum order quantity : 80 x 25 mm	50 units
Minimum order quantity : 60 x 25 mm	100 units
Other types : minimum quantity	500 units

7

To order, see page 13

Dimensions

60 x 25

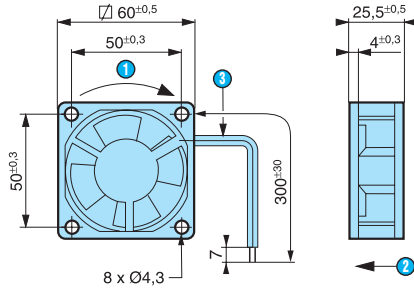

- 1 Rotation
- 2 Air flow
- 3 UL 1007 24 AWG\+ red\ black

40 x 10

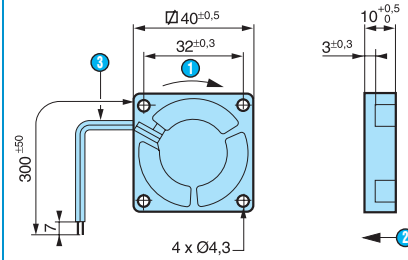

- 1 Rotation
- 2 Air flow
- 3 UL 1007 24 AWG\+ red\ black

25 x 10

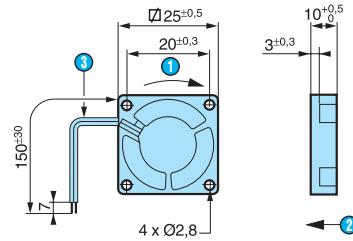

- 1 Rotation
- 2 Air flow
- 3 UL 1007 24 AWG\+ red\ black

120 x 38

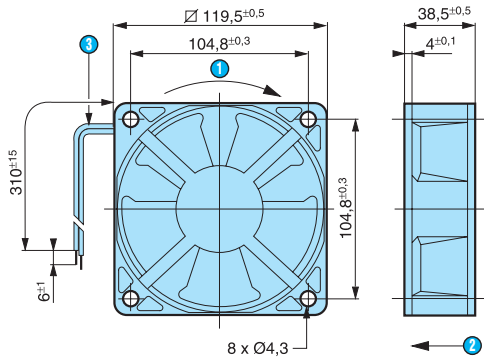

- 1 Rotation
- 2 Air flow
- 3 UL 1007 24 AWG\+ red\ black

92 x 25

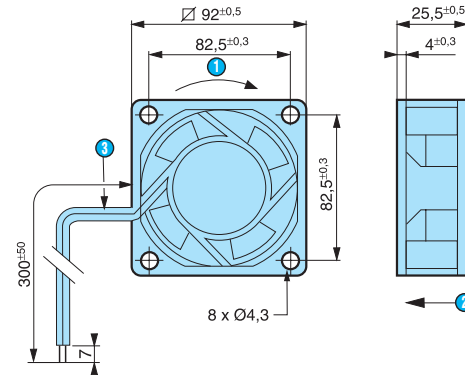

- 1 Rotation
- 2 Air flow
- 3 UL 1007 24 AWG\+ red\ black

80 x 25

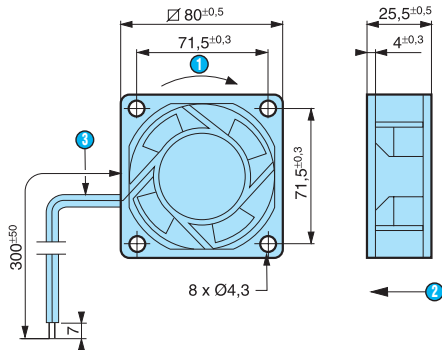

- 1 Rotation
- 2 Air flow
- 3 UL 1007 24 AWG\+ red\ black

60 x 15

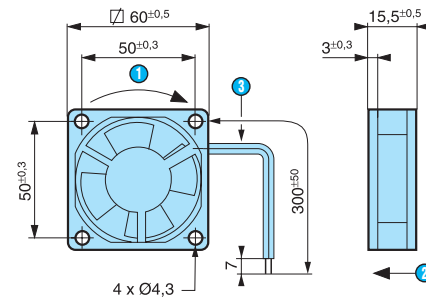

- 1 Rotation
- 2 Air flow
- 3 UL 1007 24 AWG\+ red\ black

40 x 20

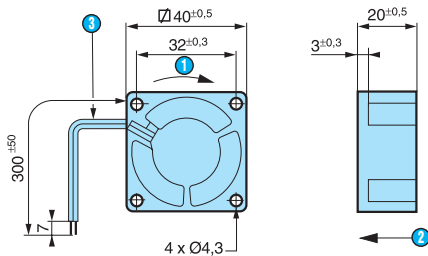

- 1 Rotation
- 2 Air flow
- 3 UL 1007 24 AWG\+ red\ black

Air performance

99 484 201 / 204 - 99 484 203 / 206

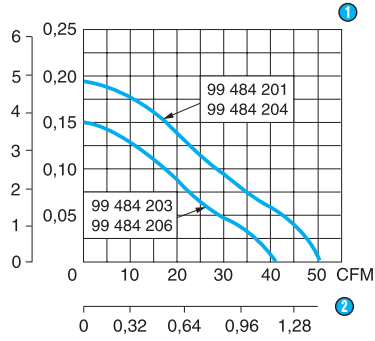

- 1 Air flow
- 2 m³/min

99 484 501

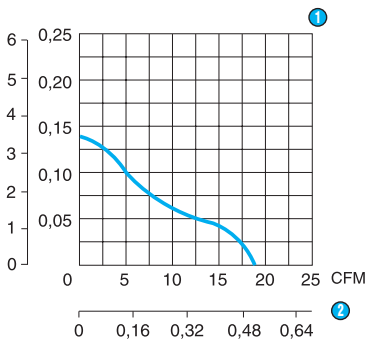

- 1 Air flow
- 2 m³/min

99 484 801

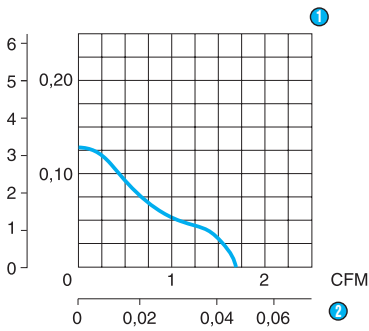

- 1 Air flow
- 2 m³/min

99 484 301 / 304 - 99 484 303 / 306

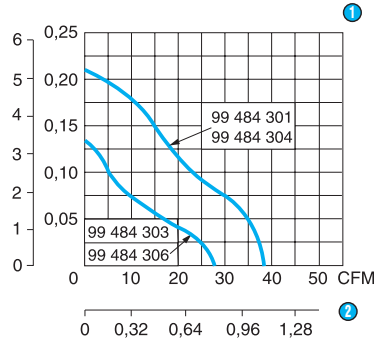

- 1 Air flow
- 2 m³/min

99 484 601

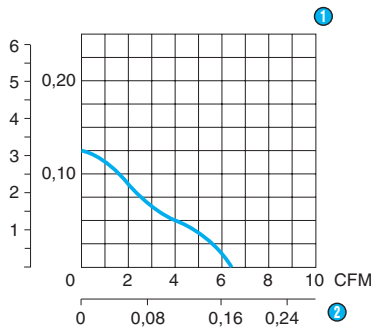

- 1 Air flow
- 2 m³/min

99 487 002 - 99 484 006

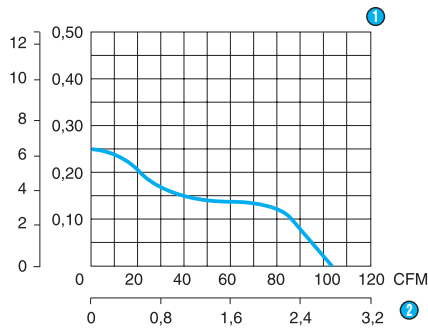

- 1 Air flow
- 2 m³/min

99 484 401 - 99 484 403

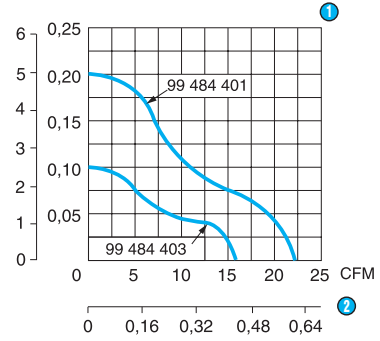

- 1 Air flow
- 2 m³/min

99 484 701

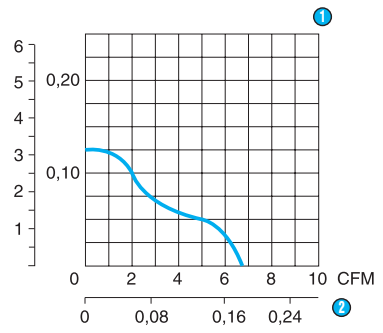

- 1 Air flow
- 2 m³/min

Accessories for fans

→ Accessories



Specifications

Designation	Fingerguard metal	Fingerguard plastic	Cord type T	Filter
Carré 40 mm	99 485 910			
Carré 60 mm	99 485 900	99 485 923		
Carré 80 mm	99 485 901	99 485 922		
Carré 92 mm	99 485 904	99 485 921		
Carré 120 mm	99 485 902	99 485 920		
Longueur 300 mm			99 485 903	
Longueur 600 mm			99 485 905	
Longueur 1000 mm			99 485 906	
Longueur 2000 mm			99 485 907	
Longueur 3000 mm			99 485 908	
Filter pour ventilateur - 120 x 120				99 485 909
Protection + filtre + carter				
General characteristics				
Products in conformity with UL - CSA - VDE	✓	-	✓	-
Material	-	-	-	UL 94 - V0

Dimensions

Metal fingerguard

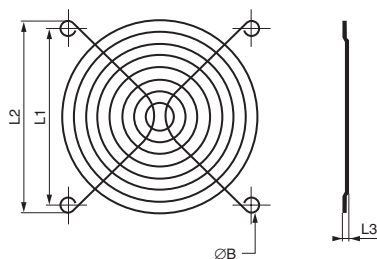

Plastic fingerguard

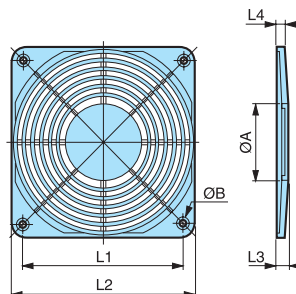

Cord

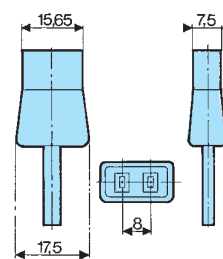

Filter

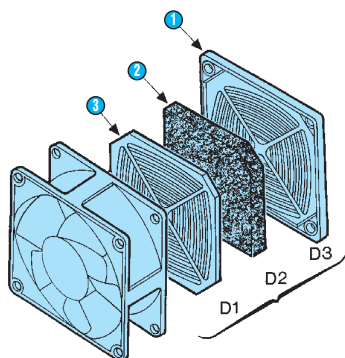

- 1 Cover
- 2 Filter
- 3 Protection

Protection

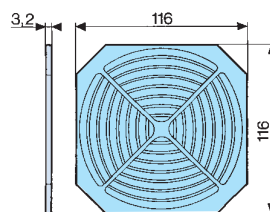

Cover

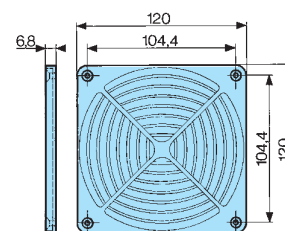

To order, see page 13

	L1	L1	L2	L2	L3	L3	L4	ØA	ØB
	plastic	metal	plastic	metal	plastic	metal			
☑ 40 mm	-	-	-	32	-	5 ^{±0.35}	-	-	4 ^{±0.05}
☑ 60 mm	50	48.0	60	53.5	7.3	5	3.8	25	4.5
☑ 80 mm	71.5	71.4	80	76.4	7.3	5	3.8	34	4.5
☑ 92 mm	82.5	82.5	92	89.4	7.3	5.5	3.8	34	4.5
☑ 120 mm	105	104.5	120	115.5	7	5.5	3.7	49	4.5

Index by part number

Part numbers	Description	Page
26 000 000		
26 231 145	Capacitor - 12 µF 63 V	105
26 231 703	Capacitor - 22 µF 63 V	109
26 231 708	Capacitor - 6,8 µF 63 V	103
26 231 711	Capacitor - 8,2 µF 70 V	103
26 231 720	Capacitor - 10 µF 100 V	107
26 231 728	Capacitor - 15 µF 70 V	105
26 231 801	Capacitor - 0,33 µF 400 V	103
26 231 822	Capacitor - 0,56 µF 400 V	109
26 231 851	Capacitor - 0,27 µF 250 V	103
26 231 903	Capacitor - 0,12 µF 600 V	105
26 231 909	Capacitor - 0,22 µF 630 V	109
26 231 924	Capacitor - 0,39 µF 630 V	103
26 231 941	Capacitor - 0,10 µF 700 V	105

79 000 000

79 294 790	Programming cable PC/Motomate - USB port	88
79 294 791	Programming cable PC/Motomate - serial port	88
79 294 792	Motomate - Programming software	88

80 000 000

80 080 005	Motomate - Brushless motor with integrated logic controller - Motor direct drive	88
80 081 001	Motomate - Brushless motor with integrated logic controller - Right angle gearbox	88
80 081 002	Motomate - Brushless motor with integrated logic controller - Right angle gearbox	88
80 081 003	Motomate - Brushless motor with integrated logic controller - Right angle gearbox	88
80 081 004	Motomate - Brushless motor with integrated logic controller - Right angle gearbox	88
80 081 006	Motomate - Brushless motor with integrated logic controller - Right angle gearbox	88
80 089 704	Motomate - Brushless motor with integrated logic controller - Planetary gearboxes	88
80 089 705	Motomate - Brushless motor with integrated logic controller - Planetary gearboxes	88
80 089 706	Motomate - Brushless motor with integrated logic controller - Planetary gearboxes	88
80 140 004	Direct drive BRUSHLESS DC motors - 30 Watts	76
80 141 001	BRUSHLESS DC geared motors - 1 stage	80
80 141 002	BRUSHLESS DC geared motors - 1 stage	80
80 141 003	BRUSHLESS DC geared motors - 1 stage	80
80 141 004	BRUSHLESS DC geared motors - 1 stage	80
80 141 006	BRUSHLESS DC geared motors - 1 stage	80
80 149 604	BRUSHLESS DC geared motors - 1 stage	81
80 149 605	BRUSHLESS DC geared motors - 2 stages	81
80 149 606	BRUSHLESS DC geared motors - 3 stages	81
80 180 001	Direct drive BRUSHLESS DC motors - 80 Watts PWM control	78
80 180 002	Direct drive BRUSHLESS DC motors - 80 Watts 0-10 V control	78
80 181 001	BRUSHLESS DC geared motors - 80 Watts PWM control	82
80 181 002	BRUSHLESS DC geared motors - 80 Watts PWM control	82
80 181 003	BRUSHLESS DC geared motors - 80 Watts PWM control	82
80 181 004	BRUSHLESS DC geared motors - 80 Watts PWM control	82
80 181 006	BRUSHLESS DC geared motors - 80 Watts PWM control	82

Part numbers	Description	Page
80 181 010	BRUSHLESS DC geared motors - 80 Watts 0-10 V control	82
80 181 011	BRUSHLESS DC geared motors - 80 Watts 0-10 V control	82
80 181 012	BRUSHLESS DC geared motors - 80 Watts 0-10 V control	82
80 181 013	BRUSHLESS DC geared motors - 80 Watts 0-10 V control	82
80 181 015	BRUSHLESS DC geared motors - 80 Watts 0-10 V control	82
80 189 701	BRUSHLESS DC geared motors - 1 stage	83
80 189 702	BRUSHLESS DC geared motors - 2 stages	83
80 189 703	BRUSHLESS DC geared motors - 3 stages	83
80 189 704	BRUSHLESS DC geared motors - 1 stage	84
80 189 705	BRUSHLESS DC geared motors - 2 stages	84
80 189 706	BRUSHLESS DC geared motors - 3 stages	84
80 337 506	Single direction synchronous geared motors - 3.5 Watts	118
80 337 507	Single direction synchronous geared motors - 3.5 Watts	118
80 337 508	Single direction synchronous geared motors - 3.5 Watts	118
80 337 509	Single direction synchronous geared motors - 3.5 Watts	118
80 337 514	Single direction synchronous geared motors - 3.5 Watts	118
80 337 515	Single direction synchronous geared motors - 3.5 Watts	118
80 337 516	Single direction synchronous geared motors - 3.5 Watts	118
80 337 517	Single direction synchronous geared motors - 3.5 Watts	118
80 337 518	Single direction synchronous geared motors - 3.5 Watts	118
80 337 519	Single direction synchronous geared motors - 3.5 Watts	118
80 337 522	Single direction synchronous geared motors - 3.5 Watts	118
80 337 523	Single direction synchronous geared motors - 3.5 Watts	118
80 337 524	Single direction synchronous geared motors - 3.5 Watts	118
80 337 525	Single direction synchronous geared motors - 3.5 Watts	118
80 337 528	Single direction synchronous geared motors - 3.5 Watts	118
80 337 529	Single direction synchronous geared motors - 3.5 Watts	118
80 337 530	Single direction synchronous geared motors - 3.5 Watts	118
80 337 532	Single direction synchronous geared motors - 3.5 Watts	118
80 337 533	Single direction synchronous geared motors - 3.5 Watts	118
80 337 534	Single direction synchronous geared motors - 3.5 Watts	118
80 337 537	Single direction synchronous geared motors - 3.5 Watts	118
80 337 538	Single direction synchronous geared motors - 3.5 Watts	118
80 337 539	Single direction synchronous geared motors - 3.5 Watts	118
80 337 541	Single direction synchronous geared motors - 3.5 Watts	118
80 510 0	Linear actuators synchronous- 230 V	170
80 510 5	Linear actuators synchronous- 230 V	170
80 527 001	Reversible synchronous geared motors - 3.5 Watts	132

Index by part number

Part numbers	Description	Page
80 527 002	Reversible synchronous geared motors - 3.5 Watts	132
80 527 003	Reversible synchronous geared motors - 3.5 Watts	132
80 527 005	Reversible synchronous geared motors - 3.5 Watts	132
80 527 006	Reversible synchronous geared motors - 3.5 Watts	132
80 527 008	Reversible synchronous geared motors - 3.5 Watts	132
80 527 010	Reversible synchronous geared motors - 3.5 Watts	132
80 547 015	Reversible synchronous geared motors - 7.2 Watts	134
80 547 016	Reversible synchronous geared motors - 7.2 Watts	134
80 547 017	Reversible synchronous geared motors - 7.2 Watts	134
80 547 018	Reversible synchronous geared motors - 7.2 Watts	134
80 547 019	Reversible synchronous geared motors - 7.2 Watts	134
80 547 020	Reversible synchronous geared motors - 7.2 Watts	134
80 547 021	Reversible synchronous geared motors - 7.2 Watts	134
80 547 024	Reversible synchronous geared motors - 7.2 Watts	134
80 803 005	D.C. geared motors with brushes - 17 Watts	46
80 803 006	D.C. geared motors with brushes - 17 Watts	46
80 803 007	D.C. geared motors with brushes - 17 Watts	46
80 803 008	D.C. geared motors with brushes - 17 Watts	46
80 803 009	D.C. geared motors with brushes - 17 Watts	46
80 803 010	D.C. geared motors with brushes - 17 Watts	46
80 804 006	D.C. geared motors with brushes - 17 Watts	48
80 804 007	D.C. geared motors with brushes - 17 Watts	48
80 804 008	D.C. geared motors with brushes - 17 Watts	48
80 804 009	D.C. geared motors with brushes - 17 Watts	48
80 804 010	D.C. geared motors with brushes - 17 Watts	48
80 804 011	D.C. geared motors with brushes - 17 Watts	48
80 807 001	D.C. geared motors with brushes - 17 Watts	54
80 807 012	D.C. geared motors with brushes - 17 Watts	54
80 807 013	D.C. geared motors with brushes - 17 Watts	54
80 807 014	D.C. geared motors with brushes - 17 Watts	54
80 807 015	D.C. geared motors with brushes - 17 Watts	54
80 807 016	D.C. geared motors with brushes - 17 Watts	54
80 807 017	D.C. geared motors with brushes - 17 Watts	54
80 807 018	D.C. geared motors with brushes - 17 Watts	54
80 807 019	D.C. geared motors with brushes - 17 Watts	54
80 807 020	D.C. geared motors with brushes - 17 Watts	54
80 807 021	D.C. geared motors with brushes - 17 Watts	54
80 807 022	D.C. geared motors with brushes - 17 Watts	54
80 835 002	D.C. geared motors with brushes - 33 Watts	56
80 835 003	D.C. geared motors with brushes - 33 Watts	56
80 835 004	D.C. geared motors with brushes - 33 Watts	56
80 835 005	D.C. geared motors with brushes - 33 Watts	56
80 835 006	D.C. geared motors with brushes - 33 Watts	56
80 835 008	D.C. geared motors with brushes - 33 Watts	56
80 835 009	D.C. geared motors with brushes - 33 Watts	56
80 835 012	D.C. geared motors with brushes - 33 Watts	56

Part numbers	Description	Page
80 835 013	D.C. geared motors with brushes - 33 Watts	56
80 835 014	D.C. geared motors with brushes - 33 Watts	56
80 835 015	D.C. geared motors with brushes - 33 Watts	56
80 835 016	D.C. geared motors with brushes - 33 Watts	56
80 835 017	D.C. geared motors with brushes - 33 Watts	56
80 835 018	D.C. geared motors with brushes - 33 Watts	56
80 910 0	Linear actuators stepper - 7,5°	172
80 910 5	Linear actuators stepper - 15°	174
80 913	Geared stepper motors - 2,5 Watts	162
80 923	Geared stepper motors - 3,5 Watts	162
80 927 006	Geared stepper motors - 7.5 Watts	164
80 927 019	Geared stepper motors - 7.5 Watts	164
80 927 020	Geared stepper motors - 7.5 Watts	164
80 933	Geared stepper motors - 3,5 Watts	162
80 947 001	Geared stepper motors - 12.5 Watts	166
80 947 010	Geared stepper motors - 12.5 Watts	166
80 947 019	Geared stepper motors - 12.5 Watts	166
80 947 020	Geared stepper motors - 12.5 Watts	166

82 000 000

82 330 582	Direct drive single direction synchronous motors - 0.42 Watts	101
82 330 583	Direct drive single direction synchronous motors - 0.42 Watts	101
82 334 726	Single direction synchronous geared motors - 3.5 Watts	110
82 334 728	Single direction synchronous geared motors - 3.5 Watts	110
82 334 730	Single direction synchronous geared motors - 3.5 Watts	110
82 334 731	Single direction synchronous geared motors - 3.5 Watts	110
82 334 733	Single direction synchronous geared motors - 3.5 Watts	110
82 334 734	Single direction synchronous geared motors - 3.5 Watts	110
82 334 736	Single direction synchronous geared motors - 3.5 Watts	110
82 334 738	Single direction synchronous geared motors - 3.5 Watts	110
82 334 739	Single direction synchronous geared motors - 3.5 Watts	110
82 334 741	Single direction synchronous geared motors - 3.5 Watts	110
82 334 742	Single direction synchronous geared motors - 3.5 Watts	110
82 334 744	Single direction synchronous geared motors - 3.5 Watts	110
82 334 748	Single direction synchronous geared motors - 3.5 Watts	110
82 334 751	Single direction synchronous geared motors - 3.5 Watts	110
82 334 756	Single direction synchronous geared motors - 3.5 Watts	110
82 334 758	Single direction synchronous geared motors - 3.5 Watts	110
82 334 759	Single direction synchronous geared motors - 3.5 Watts	110
82 334 760	Single direction synchronous geared motors - 3.5 Watts	110
82 334 761	Single direction synchronous geared motors - 3.5 Watts	110
82 334 764	Single direction synchronous geared motors - 3.5 Watts	110
82 334 766	Single direction synchronous geared motors - 3.5 Watts	110

Index by part number

Part numbers	Description	Page
82 869 008	D.C. geared motors with brushes - 3.9 Watts	40
82 869 009	D.C. geared motors with brushes - 3.9 Watts	40
82 869 010	D.C. geared motors with brushes - 3.9 Watts	40
82 869 011	D.C. geared motors with brushes - 3.9 Watts	40
82 869 012	D.C. geared motors with brushes - 3.9 Watts	40
82 869 013	D.C. geared motors with brushes - 3.9 Watts	40
82 869 014	D.C. geared motors with brushes - 3.9 Watts	40
82 869 015	D.C. geared motors with brushes - 3.9 Watts	40
82 869 016	D.C. geared motors with brushes - 3.9 Watts	40
82 890 001	D.C. direct drive brushed motors - 194 Watts	32
82 890 002	D.C. direct drive brushed motors - 255 Watts	32
82 910 001	Direct drive stepper motors - 2 phases	148
82 910 501	Direct drive stepper motors - 2 phases	146
82 910 502	Direct drive stepper motors - 4 phases	146
82 920 001	Direct drive stepper motors - 2 phases	152
82 920 012	Direct drive stepper motors - 4 phases	152
82 924 020	Geared stepper motors - 7.5 Watts	158
82 924 022	Geared stepper motors - 7.5 Watts	158
82 924 028	Geared stepper motors - 7.5 Watts	158
82 924 030	Geared stepper motors - 7.5 Watts	158
82 930 002	Direct drive stepper motors - 2 phases	154
82 930 015	Direct drive stepper motors - 4 phases	154
82 940 002	Direct drive stepper motors - 2 phases	156
82 940 015	Direct drive stepper motors - 4 phases	156

Part numbers	Description	Page
99 485 923	Accessories for fans - Fingerguard plastic 60x60	186
99 486 804	AC fan - 80 x 25 mm	180
99 486 904	AC fan - 80 x 38 mm	180
99 487 102	AC fan - 92 x 25 mm	180
99 487 401	AC fan - 120 x 38 mm	180
99 487 403	AC fan - 120 x 38 mm	180
99 487 411	AC fan - 120 x 38 mm	180
99 487 420	AC fan - 120 x 38 mm	180
99 489 401	AC fan - 120 x 38 mm	180

99 000 000

99 484 002	DC brushless fan - 120 x 38 mm	182
99 484 006	DC brushless fan - 120 x 38 mm	182
99 484 201	DC brushless fan - 92 x 25 mm	182
99 484 203	DC brushless fan - 92 x 25 mm	182
99 484 204	DC brushless fan - 92 x 25 mm	182
99 484 206	DC brushless fan - 92 x 25 mm	182
99 484 301	DC brushless fan - 80 x 25 mm	182
99 484 303	DC brushless fan - 80 x 25 mm	182
99 484 304	DC brushless fan - 80 x 25 mm	182
99 484 306	DC brushless fan - 80 x 25 mm	182
99 484 401	DC brushless fan - 60 x 25 mm	182
99 484 403	DC brushless fan - 60 x 25 mm	182
99 484 501	DC brushless fan - 60 x 15 mm	182
99 484 601	DC brushless fan - 40 x 20 mm	182
99 484 701	DC brushless fan - 40 x 10 mm	182
99 484 801	DC brushless fan - 25 x 10 mm	182
99 485 900	Accessories for fans - Fingerguard metal 60x60	186
99 485 901	Accessories for fans - Fingerguard metal 80x80	186
99 485 902	Accessories for fans - Fingerguard metal 120x120	186
99 485 903	Accessories for fans - Cord type T 300 mm	186
99 485 904	Accessories for fans - Fingerguard metal 92x92	186
99 485 905	Accessories for fans - Cord type T 600 mm	186
99 485 906	Accessories for fans - Cord type T 1000 mm	186
99 485 907	Accessories for fans - Cord type T 2000 mm	186
99 485 908	Accessories for fans - Cord type T 3000 mm	186
99 485 909	Accessories for fans - Filter 120x120	186
99 485 910	Accessories for fans - Fingerguard metal 40x40	186
99 485 920	Accessories for fans - Fingerguard plastic 120x120	186
99 485 921	Accessories for fans - Fingerguard plastic 92x92	186
99 485 922	Accessories for fans - Fingerguard plastic 80x80	186

Conditions of sale

1. Acceptance

All orders are accepted subject to the following Conditions of Sale which cannot be varied except expressly and in writing by us. These terms and conditions shall prevail over any terms and conditions contained in a purchaser's order. Any sale by us to purchaser subsequent to an order or other notification incorporating any Conditions of Purchase of the Purchaser shall not be deemed to constitute an acceptance by us of the purchaser's Conditions of Purchase.

2. Prices and discounts

All prices and discount rates are subject to alteration without notice and the rate applicable to a particular order will be our price and discount rates current at the date of despatch irrespective of the price and discount rate stated in our acknowledgement. Minimum order charge payable.

3. Payment

Payment must be made with the order in cash without any deduction (other than any discount rate previously agreed by us) unless monthly or other terms have been approved by us prior to the order being made.

4. Despatch dates

Despatch dates given are based on our best information at the time quoted, but are given as estimates only. We reserve the right to postpone any quoted despatch or delivery dates without prior notice and without liability for any delay. Delivery weeks are numbered 1-52 from January to December.

5. Cancellation or amendment

We reserve the right to cancel or amend a purchaser's order if it is impractical or impossible for us to fulfil the order by reason of any act of God, war, civil disturbance, strike, lockout, cessation of work, combination of workmen or employees, legislation or restriction of any governmental or other authority, breakdown or interruption of transport, force majeure or any other circumstances beyond our control and in such circumstances the obligations of each part hereunder shall be wholly or partially suspended during the continuance and to the extent of such prevention, interruption or hindrance.

6. Descriptions

Technical information relating to our products as set out in our catalogue(s) and description literature may be varied by us from time to time due to manufacturing and other factors. Every effort will be made to keep our literature and catalogues up-to-date but the purchaser should make specific enquiries and satisfy himself that any order given by him is of products and specifications currently available, and supplied by us at the time the order is given. Every endeavour will be made by us to correct and up-date our literature from time to time as the situation shall require but we accept no liability for minor or trifling misdescription.

7. Delivery complaints

Non delivery within 10 days of the date of despatch must be reported immediately in writing to us and to the carriers. Any damage or shortfall in delivery must be reported in writing to us within three days of delivery giving a statement of the alleged shortfall or damage. We shall not be liable for any claims in respect of the above complaints unless they have been reported in accordance with this Clause.

8. Warranty

We shall repair or, at our option, replace without charge any products manufactured and supplied by us hereunder which prove defective within twelve months from the date of despatch PROVIDED ALWAYS, that

- a) such products have not been structurally modified or misused or misapplied;
 - b) they are returned to us carriage paid;
 - c) all terms agreed by us for payment of such goods have been strictly complied with;
 - d) any claim hereunder is made within 30 days of the date of discovery of the defect.
- PROVIDED THAT this Warranty shall not extend to any prototype(s) nor any pre-production batch supplied for customer evaluation. Where it appears to us following an inspection of the return of goods that no defect rendering the goods unmerchantable or fit for their purpose exists or has existed since despatch by us we shall be entitled at our absolute discretion to return the goods henceforth to the buyer who shall thereupon bear and be responsible for cost of carriage thereby incurred.

Save as provided above we accept no liability in contract or tort whatsoever in respect of defects in goods sold by us save where such liability cannot be limited or excluded in law.

9. Errors

We reserve the right to correct all typographical and clerical errors and the purchaser may not rely on any such information thus erroneously provided.

10. Proper law

The parties hereby agree that any contract made between them and any question thereby arising shall be governed by English law.

11. Intellectual property

The purchaser hereby agrees and undertakes not to copy, publicise or make available to any third party any drawings, designs, patterns, tooling written instructions, software specifications etc produced and supplied by us in connection with any order placed under these conditions save in accordance with any licence granted by us and it is hereby agreed that the same shall remain our property and must be returned to us on demand free of charge. Where software is incorporated in our product and sold to the purchaser as a package the software remains our property and the purchaser has a no-exclusive right of use.

As a consequence, the purchaser is forbidden to reproduce, except for the purchaser's own security copy purposes, alter or publish such software as is marketed by us or otherwise inform unauthorised persons.

12. Title

We retain ownership in the goods until full payment has been made and goods supplied that have not been paid for must be held by the purchaser on our behalf as follows :

- a) It shall be the duty of the purchaser to preserve and store goods delivered in an identifiable form and not to mix or make the said goods until payment is received by us in full, unless written consent is otherwise given. Further if such written consent is given, it is agreed that you will hold the proceeds of sale on trust for us in a separate identifiable bank account until the payment is made in full.
- b) It is further hereby agreed that in the event of the purchaser becoming bankrupt or having a Receiving Order or Administration Order made or making arrangements with creditors for commencing to be wound up then the purchaser will notify us forthwith and we shall be entitled to give notices and instructions to the purchaser in accordance with clause (a) above. Nothing in this sub-clause shall prejudice our rights with regard to clause (a) above.

13. Minimum order charge

£100 (excluding Post and Packing)+VAT. Orders for less than £100 will be charged as £100. VAT will be added at the relevant rate.



Crouzet around the world

AUSTRIA

Crouzet GmbH
Zweigniederlassung Österreich
Spengergasse 1/3
A-1050 WIEN
Tel. : +43(0) 1/36 85 471
Fax : +43(0) 1/36 85 472
E-mail : com-at@crouzet.com
www.crouzet.at



Crouzet Direct

Tel. : +49(0) 21 03/980 171
Tel. : +49(0)21 03/980 222
E-mail : info-direkt@crouzet.com

BELGIUM

Crouzet NV/SA
Koning Albert I Laan 40
1780 Wemmel
Tel. : +32 (0) 2 462 07 30
Fax : +32 (0) 2 461 00 23
E-mail : com-be@crouzet.com
www.crouzet.be



Crouzet Direct

Tel. : +33 825 333 350 (FR)
Tel. : +33 475 802 104 (NL)
Fax : +33 475 802 120
E-mail : infocom@to.crouzet.com

BRAZIL

Crouzet do Brasil Ltda
Rua Gal.Furtado Nascimento,
740 - sl. 77 Alto de Pinheiros
CEP: 05465-070 São Paulo
SP - Brasil
Tel. : (11) 3026 9008
Fax : (11) 3026 9009
E-mail : crz-infobrasil@crouzet.com
www.crouzet.com



Crouzet Direct

Tel. : +33 475 802 102
Fax : +33 475 802 120
E-mail : infocom@to.crouzet.com

CHINA

Crouzet Asia
Dynasty Business Center,
310-3F
457 Wu Lu Mu Qi (N) Road
SHANGHAI
Tel. : +(86-21) 62 49 09 10
Fax +(86-21) 62 49 07 01
E-mail : com-cn@crouzet.com
www.crouzet.com



Crouzet Direct

Tel. : +33 475 802 102
Fax : +33 475 802 120
E-mail : infocom@to.crouzet.com

FRANCE

Crouzet Automatismes SAS
Ventes France
2 rue du docteur Abel
BP 59 - 26 902 Valence
cedex 9
Tel. : 04 75 44 88 44
Fax N° Azur : 0 810 61 01 02
E-mail : com-fr@crouzet.com
www.crouzet.fr



Crouzet Direct

N° Indigo 0 825 33 33 50
Fax : 04 75 80 21 20
E-mail : infocom@to.crouzet.com

GERMANY

Crouzet GmbH
Otto-Hahn Str.3
D-40721 HILDEN
Postfach 203
D-40702 HILDEN
Tel. : +49(0) 21 03/980-0
Fax : +49(0)21 03/980-200
E-mail : com-de@crouzet.com
www.crouzet.de



Crouzet Direct

Tel. : +49(0) 21 03/980 151/171
Tel. : +49(0) 21 03/980 222
E-mail : info-direkt@crouzet.com

INDIA

Crouzet India
India liaison office
Unit No. 3-D,
"SPL ENDERLY" III Floor,
26, Cubbon road
BANGALORE 560 001
Tel.: +91 80 309 02 245
Fax: +91 80 512 38 066
E-mail: crz_bangalore@crouzet.com
www.crouzet.com



Crouzet Direct

Tel. : +33 475 802 102
Fax : +33 475 802 120
E-mail : infocom@to.crouzet.com

ITALY

Crouzet Componenti s.r.l.
Via Brembo, 23
20139 Milano
Tel. : +39 02 57 306 611
Fax : +39 02 57 306 723
E-mail : com-it@crouzet.com



Crouzet Direct

Crouzet Mexicana SA
Aguiles Serdan n° 416
San Felipe Hueyotlipan C.P.
72030 - Puebla Mexico
Tel : +52 22 24 20 29/ 30
Fax : +52 22 24 21 47
E-mail : com-mx@crouzet.com
www.crouzet.com



Crouzet Direct

Tel. : +52 (55) 5804 5544/5
Toll Free: 01 800 706 0600
Fax : +52 (55) 5686 2710
E-mail : customer.service@us.crouzet.com

SPAIN

Crouzet España
C/ Aragón 224
08011 Barcelona
Tel. : +34 93 484 39 70
Fax : +34 93 484 39 73
E-mail : es-consultas@crouzet.es
www.crouzet.es



Crouzet Direct

Tel. : +33 475 802 103
Fax : +33 475 802 120
E-mail : infocom@to.crouzet.com

SWEDEN

Crouzet AB
Malmgårdsvägen 63
Box 11183 - SE. 100 61
Stockholm
Tel. : +46-8 556 02 200
Fax : +46-8 556 02 229
E-mail : crouzet@crouzet.se
www.crouzet.se



Crouzet Direct

Tel. : +46-8-556 02 210
Fax : +46-8 556 02 229
E-mail : order@crouzet.se

SWITZERLAND

Crouzet AG
Gewerbepark - Postfach 56
CH-5506 MÄGENWIL
Tel. : +41(0) 62/887 30 30
Fax : +41(0) 62/887 30 40
E-mail : com-ch@crouzet.com
www.crouzet.ch



Crouzet Direct

Tel. : +41(0) 62/887 30 30
Fax : +41(0) 62/887 30 40
E-mail : info-direkt@crouzet.com

THE NETHERLANDS

Crouzet BV
Industrieweg 17
2382 NR Zoeterwoude
Tel. : +31 (0)71-581 20 30
Fax : +31 (0)71-541 35 74
E-mail : com-nl@crouzet.com
www.crouzet.nl



Crouzet Direct

Tel. : +33 475 802 104
Fax : +33 475 802 120
E-mail : infocom@to.crouzet.com

UNITED KINGDOM

Crouzet Ltd
Interco 3 - Wade Road
Basingstoke - Hampshire
RG24 8NE
Tel. : +44 (0)1256 318 900
Fax : +44 (0)1256 318 901
E-mail : info@crouzet.co.uk
www.crouzet.co.uk



Crouzet Direct

Crouzet North America
204 airline drive, suite 300
Coppell Texas 75019
Tel. : +1 972 471-2565
Fax : +1 972 471-2560
E-mail : sales.info@us.crouzet.com
www.crouzet-usa.com



Crouzet Direct

Tel. : 1 800 677 5311
Fax : 1 800 677 3865
E-mail : customer.service@us.crouzet.com

OTHER COUNTRIES

Crouzet Automatismes SAS
Division Ventes Internationales
2 rue du docteur Abel - BP 59
26902 Valence cedex 9 - Fr
Tel. : +33 475 448 936
Fax : +33 475 448 126
E-mail : com-dvi@crouzet.com
www.crouzet.com



Crouzet Direct

Tel. : +33 475 802 102
Fax : +33 475 802 120
E-mail : infocom@to.crouzet.com

Warning:
The product information contained in this catalogue is given purely as information and does not constitute a representation, warranty or any form of contractual commitment. CROUZET Automatismes and its subsidiaries reserve the right to modify their products without notice. It is imperative that we should be consulted over any particular use or application of our products and it is the responsibility of the buyer to establish, particularly through all the appropriate tests, that the product is suitable for the use or application. Under no circumstances will our warranty apply, nor shall we be held responsible for any application (such as any modification, addition, deletion, use in conjunction with other electrical or electronic components, circuits or assemblies, or any other unsuitable material or substance) which has not been expressly agreed by us prior to the sale of our products.

Distributed by :

