



GE Capacitors

By REGAL-BELOIT

Capacitors for AC and DC General Purpose Applications



Proven EIA-456 Compliant

60,000 Hour Reliability Industry Standard



GE Capacitors by Regal-Beloit 1946 West Cook Road, Fort Wayne, Indiana 46818 USA

Phone: (260) 416-5400 Fax: (260) 416-5460 Email: capacitors@regalbeloit.com

www.gecapacitors.com



Capacitor Application Data Sheet

To ensure correct selection of a capacitor for your application, please provide the information indicated below. This sheet may be duplicated or additional copies may be obtained from RBC.

Of particular importance are the voltages and current waveforms complete with values of voltage and current over a complete cycle.

Send this data to your local RBC Sales Representative or directly to:

GE Capacitors by Regal-Beloit
1946 West Cook Road
Fort Wayne, Indiana 46818 USA

Phone: (260) 416-5400
Fax: (260) 416-5460
Email: capacitors@regalbeloit.com

PRIMARY INFORMATION (Essential)

1. **Application:** _____
2. **Capacitance:** _____ **Tolerance:** _____
3. **Peak Voltage:** _____ **RMS Voltage:** _____
4. **Peak Current:** _____ **RMS Current:** _____
5. **Transient Voltage:** _____ **Duration:** _____ **Freq. Of Occurrence:** _____
6. **Frequency or Repetition Rate (Hz):** _____ **Duty Cycle:** _____
7. **Ambient Temperature:** _____ **Max.:** _____ **Min.:** _____
8. **Capacitor Charge Time:** _____ **Discharge Time:** _____
9. **Required Operating Life (Hours):** _____
10. **Waveforms:**

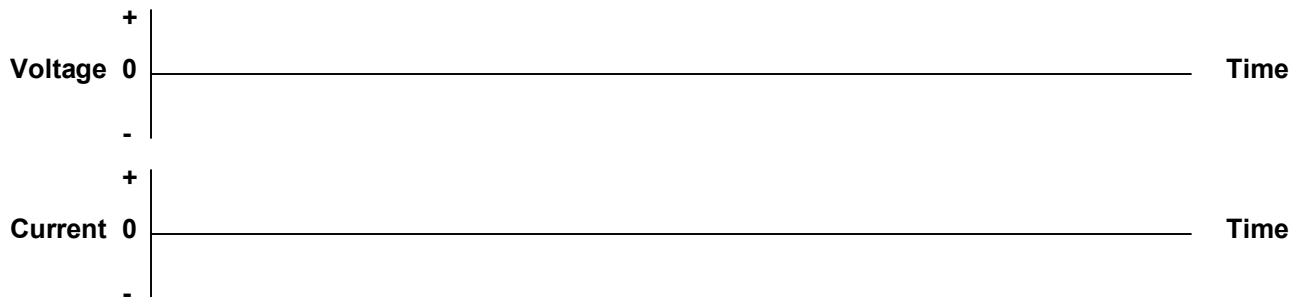

SECONDARY INFORMATION (Provide as Appropriate)

11. **Physical Size Limitations:** _____
12. **Mounting Requirements:** _____
13. **Applicable Specifications:** _____
14. **Type of Cooling Available:** _____
15. **Unusual Atmospheric Conditions:** _____
16. **Other Special Requirements:** _____
17. **Number of Samples Required:** _____
18. **Potential Usage:** _____

Descriptive Information	02
Product Safety	04
General Purpose AC Capacitors – GEM III	
240 & 370 Volts AC	
Product Specifications	06
Single Ratings – 1 Section	07
Application Notes / Data	09
600 Volts AC	
Product Specifications	14
Single Ratings – 1 Section	15
Application Notes / Data	16
660 Volts AC (Series Section)	
Product Specifications	21
Single Ratings – 1 Section	22
Application Notes / Data	23
1000 Volts DC Peak	
Product Specifications	28
Single Ratings – 1 Section	29
Cross Reference – 600 Volts AC	
26F6600 to NEW 27L	30
61L to NEW 27L	31
Mounting Hardware	32
Capacitor Label	34
Other Catalogs	35

GE Capacitors by REGAL-BELOIT

Capacitors for General Purpose Applications

Metallized film capacitors are unsurpassed in terms of size, weight, performance, and reliability for AC applications. Regal-Beloit brings over 60 year of capacitor manufacturing experience to the product lines described in this publication. These capacitors represent the best in product design for long-term reliability and safe operation. Regal-Beloit's materials, product, and process development work continue to provide capacitor users with outstanding total value.

The specific products in this bulletin are aimed at market / application segments for General Purpose, Power Supply, and Electronic Power Conversion.

The GEM III General Purpose Capacitors are used for filtering on a wide variety of light industrial equipment. The conversion of electrical power and uninterruptible power supplies and drive control systems requires filter capacitors. An application note is included to help customers in the correct choice and use of these capacitors.

GEM III Construction

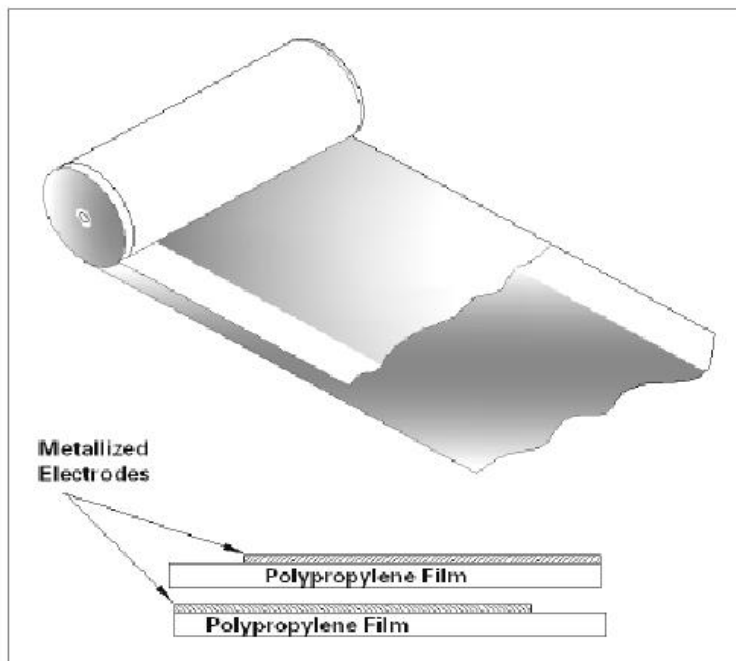

GEM III Series Construction

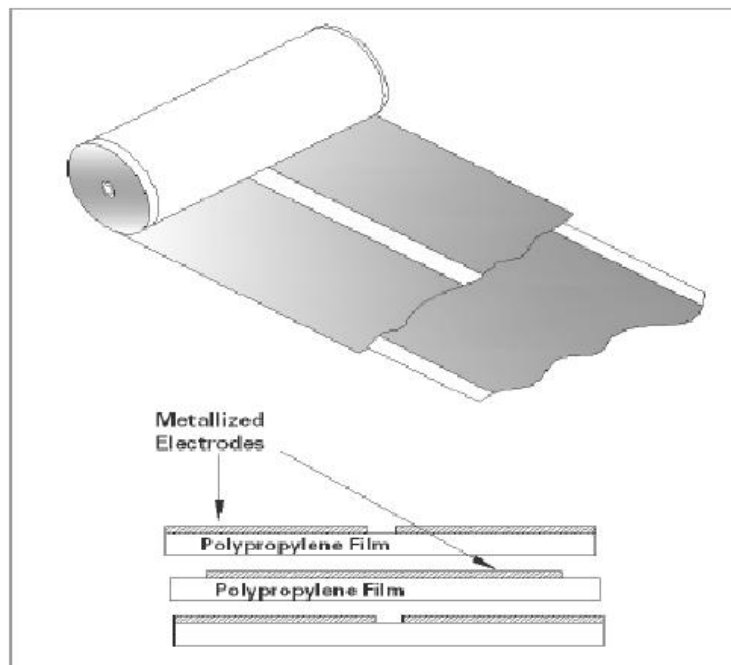

Regal-Beloit's GEM III capacitors are manufactured with high-grade metallized polypropylene film. This film is in the range of 5 to 10 microns thick, depending on the application, voltage, and conditions. The metallized electrode is several hundred angstroms thick.

The film is wound into capacitor rolls on high-speed, high-precision machines. The winding is extremely tight so that there is not enough space between the layers for corona (localized partial electrical discharges) to occur. The rolls are sprayed on both ends with metal to make the connection to the extremely thin edges of the metallized electrodes. This process is critical to the quality and performance of the capacitors.

The rolls are assembled in metal cases, Regal-Beloit's proprietary Dielektrol VI liquid is introduced under vacuum, and the capacitors are sealed. They are then subjected to 100% electrical testing for capacitance, dissipation factor, and high potential electrical withstand, both terminal-to-terminal and terminal-to-case.

Pressure Sensitive Interrupter

All the capacitors listed in this publication contain Regal-Beloit's Pressure Sensitive Interrupter (PSI). This device, developed by GE, is designed to sense the build-up of pressure within the capacitor if a fault occurs and to interrupt the internal electrical connections before the case can rupture.

The PSI carries U.L.* recognition for applications where the specified fault currents are not exceeded. The fault current is the maximum current that is available from the circuit to flow through the capacitor if the capacitor were to become a short circuit with zero impedance. **It is the responsibility of the capacitor user to determine what the available fault current is for a particular application.**

In the Catalog Number listings a four character U.L. Code, Pxxx, is given. This number is part of the listing for Regal-Beloit in U.L. File No. E7793. When applying to U.L. for approvals or recognition of equipment using these capacitors refer to the Pxxx number and not the Catalog Number of the capacitor in question.

Proper operation of the PSI requires that the cover be able to expand without restriction. The following mounting considerations should be noted in mounting the these capacitors.

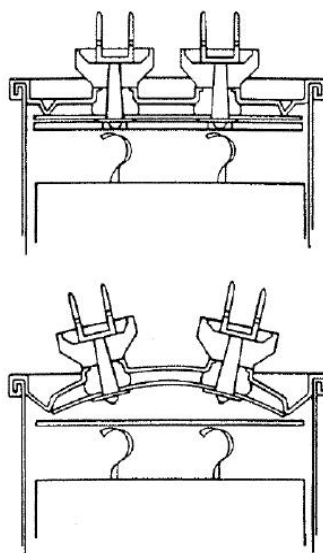

*Underwriter's Laboratory

Mounting Considerations

Vertical Clearance

There must be sufficient clearance between the tops of the terminals (and/or the assembled wire connectors) and a plane perpendicular to the capacitor terminals. This clearance must be at least 0.5 inches plus the electrical spacing requirements of the end application.

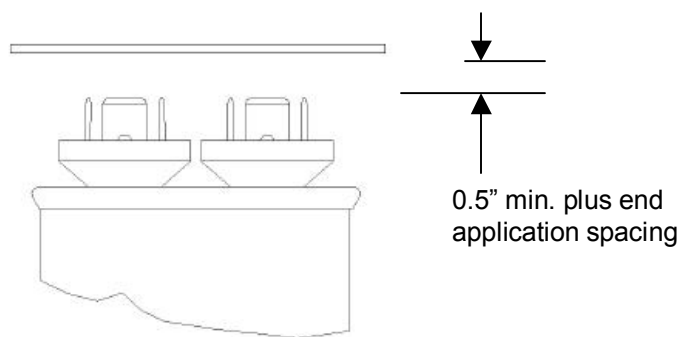

Cut-Out Clearance

In certain instances, capacitors are mounted with the top of the capacitors case resting against the chassis and the terminals protruding through the chassis. Care must be taken to see that the cutout in the chassis is large enough. The following dimensions are recommended.

Case Style	a	b
A	2.00	1.00
B	2.25	1.25
C	2.50	1.62
D	3.25	1.62

Case Style	a
P	1.62
S	1.88
T	2.38

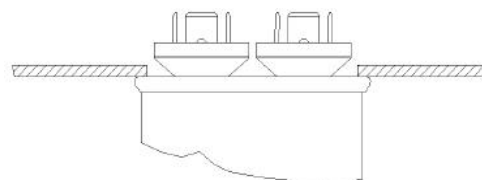
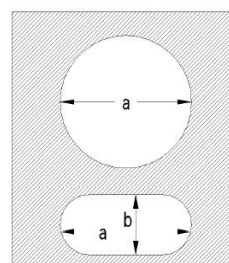

This series of GEM III is **designed specifically for applications such as AC filters where harmonic frequencies greater than 60Hz are common**. Application Data is provided starting on page 9 that gives the Equivalent Series Resistance (ESR) for these units. This allows the user to calculate the losses for each design / application and to ensure that they are kept within the permissible limits. **Any questions** regarding the suitability of a capacitor for a particular application may be referred to Regal-Beloit Engineers by **contacting your Regal-Beloit sales representative**.

SPECIFICATIONS:

Available Capacitance Range:	2 to 120 μ F
Capacitance Tolerance:	\pm 6%
Capacitance Variation with Temperature:	See Chart E-3 on page 13.
Rated Voltage:	See Rating Tables. Rating is the 60Hz RMS voltage for a sinusoidal waveform. For other waveforms refer to the Application Note on page 9.
Leakage Current:	30 μ A maximum
Frequency:	50/60 Hz. For higher frequencies refer to the Application Note on page 10.
Operating Temperature:	-40°C to +70°C
Storage Temperature:	-40°C to +90°C
Operating Life:	60,000 hours with 94% survival (In accordance with the EIA-456 Industry Standard)
Dissipation Factor:	0.1% maximum
Case Material/Finish:	Unpainted Aluminum Case, Tin Plated Steel Cover.
Terminations:	'Combo' terminal: 0.250" x 0.031" quick connect blades
Dielectric Fluid:	Dielektrol VI
Internal Protection:	UL recognized Pressure Sensitive Interrupter. See Ratings Table for Regal-Beloit's UL Code Number listed under Regal-Beloit's UL File E7793 (N). For UL submittals with these capacitors, use the RBC 'Pxxx' number not the Catalog Number. The corresponding generic UL designation that includes the Available Faults Current (AFC) rating is given below. All these capacitors are capable of interrupting available fault currents of up to 10,000 amperes.

Case Style	RBC Code	Generic UL Code
A	P921	A1000AFC
P	P965	P1000AFC
S	P968	S1000AFC
T	P969	T1000AFC

Gen Purpose AC Capacitors – GEM III

Single Ratings – 1 Section

Voltage (VAC)	Capacitance (μF)	Catalog Number	Case Style	Base Size (in.)	Can Type	Height C (in.)	UL Code
240	15.0	97F8036	P	1.75	Round	2.88	P965
	25.0	97F8037	P	1.75	Round	2.88	P965
	30.0	97F8038	P	1.75	Round	3.88	P965
	35.0	97F8039	P	1.75	Round	3.88	P965
	40.0	97F8040	P	1.75	Round	3.88	P965
	45.0	97F8041	P	1.75	Round	4.75	P965
	50.0	97F8042	P	1.75	Round	4.75	P965
	55.0	97F8043	P	1.75	Round	4.75	P965
	60.0	97F8044	S	2.00	Round	4.75	P968
	65.0	97F8045	S	2.00	Round	4.75	P968
	70.0	97F8046	S	2.00	Round	4.75	P968
	75.0	97F8047	S	2.00	Round	4.75	P968
	80.0	97F8048	T	2.50	Round	3.88	P969
	85.0	97F8049	T	2.50	Round	3.88	P969
	90.0	97F8050	T	2.50	Round	3.88	P969
	95.0	97F8051	T	2.50	Round	4.75	P969
	100.0	97F8052	T	2.50	Round	4.75	P969
120.0	97F8053	T	2.50	Round	4.75	P969	

Case Style P, S, and T

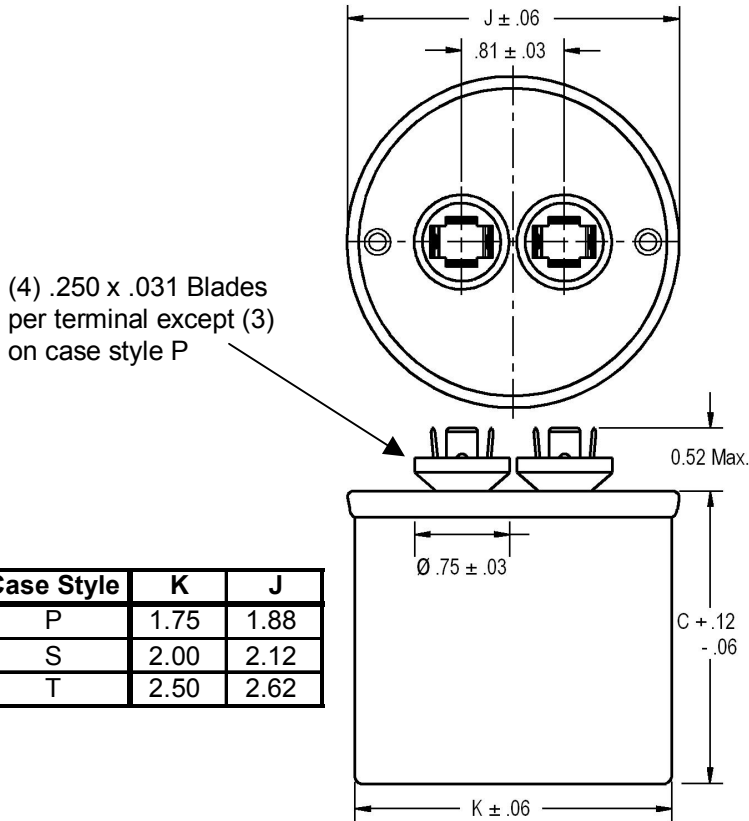

Case Style	K	J
P	1.75	1.88
S	2.00	2.12
T	2.50	2.62

*It is Regal-Beloit's goal to serve you with the most cost effective and highest quality capacitor designs. Standardization to the catalog type shown is a major program at Regal-Beloit. However, Regal-Beloit remains sensitive to your needs and requirements, and will continue to offer the above ratings (and more) in case configurations to meet your application(s).

Gen Purpose AC Capacitors – GEM III

Single Ratings – 1 Section

Voltage (VAC)	Capacitance (μF)	Catalog Number	Case Style	Base Size (in.)	Can Type	Height C (in.)	UL Code
370	3.0	97F8054	A	1.25	Oval	2.12	P921
	4.0	97F8055	A	1.25	Oval	2.12	P921
	5.0	97F8056	A	1.25	Oval	2.88	P921
	6.0	97F8057	A	1.25	Oval	2.88	P921
	7.5	97F8058	A	1.25	Oval	2.88	P921
	10.0	97F8059	A	1.25	Oval	3.88	P921
	12.5	97F8060	A	1.25	Oval	3.88	P921
	15.0	97F8061	P	1.75	Round	2.88	P965
	17.5	97F8062	P	1.75	Round	2.88	P965
	20.0	97F8063	P	1.75	Round	3.88	P965
	25.0	97F8064	P	1.75	Round	3.88	P965
	30.0	97F8065	P	1.75	Round	3.88	P965
	35.0	97F8066	P	1.75	Round	4.75	P965
	40.0	97F8067	P	1.75	Round	4.75	P965
	45.0	97F8068	S	2.00	Round	4.75	P968
	50.0	97F8069	S	2.00	Round	4.75	P968
	55.0	97F8070	S	2.00	Round	4.75	P968
	60.0	97F8071	T	2.50	Round	3.88	P969
	65.0	97F8072	T	2.50	Round	3.88	P969
	70.0	97F8073	T	2.50	Round	4.75	P969

Case Style P, S, and T

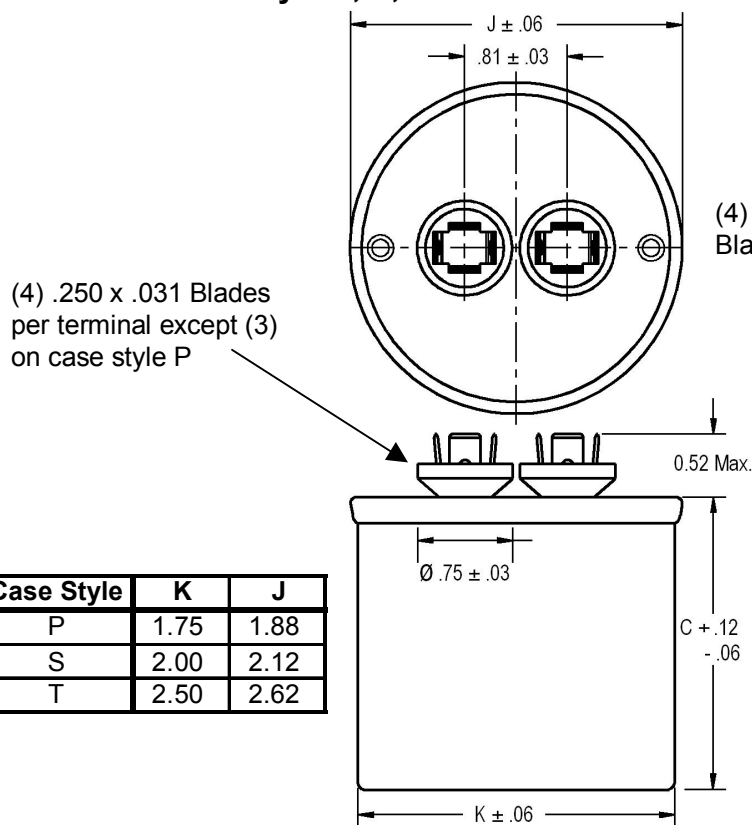

Case Style	K	J
P	1.75	1.88
S	2.00	2.12
T	2.50	2.62

Case Style A

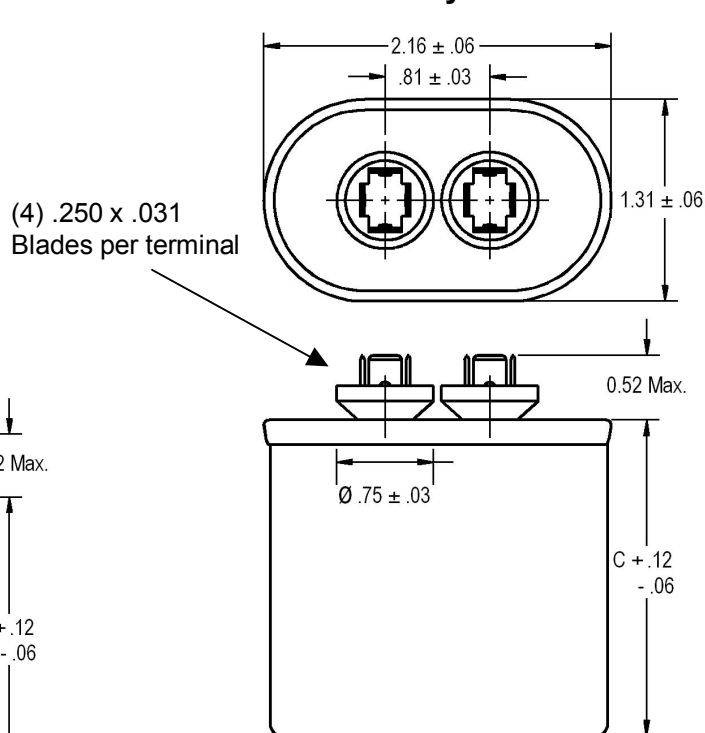

*It is Regal-Beloit's goal to serve you with the most cost effective and highest quality capacitor designs. Standardization to the catalog type shown is a major program at Regal-Beloit. However, Regal-Beloit remains sensitive to your needs and requirements, and will continue to offer the above ratings (and more) in case configurations to meet your application(s).

Gen Purpose AC Capacitors – GEM III

Application Notes – 97F8000 Series – 240 & 370 VAC

ESR Values for 97F8000 Series – Curve Numbers refer to Graphs on Page 10.

Voltage (VAC)	Catalog Number	Capacitance (μF)	ESR (ohms)	Curve Number
240	97F8036	15.0	0.0257	2
	97F8037	25.0	0.0180	2
	97F8038	30.0	0.0228	3
	97F8039	35.0	0.0206	3
	97F8040	40.0	0.0190	3
	97F8041	45.0	0.0241	4
	97F8042	50.0	0.0226	4
	97F8043	55.0	0.0213	4
	97F8044	60.0	0.0215	5
	97F8045	65.0	0.0206	5
	97F8046	70.0	0.0198	5
	97F8047	75.0	0.0191	5
	97F8048	80.0	0.0164	5
	97F8049	85.0	0.0160	5
	97F8050	90.0	0.0156	5
	97F8051	95.0	0.0193	6
	97F8052	100.0	0.0189	6
97F8053	120.0	0.0176	6	

Voltage (VAC)	Catalog Number	Capacitance (μF)	ESR (ohms)	Curve Number
370	97F8054	3.0	0.0700	1
	97F8055	4.0	0.0539	1
	97F8056	5.0	0.0586	2
	97F8057	6.0	0.0499	2
	97F8058	7.5	0.0411	2
	97F8059	10.0	0.0471	3
	97F8060	12.5	0.0392	3
	97F8061	15.0	0.0244	2
	97F8062	17.5	0.0218	2
	97F8063	20.0	0.0281	3
	97F8064	25.0	0.0240	3
	97F8065	30.0	0.0213	3
	97F8066	35.0	0.0262	4
	97F8067	40.0	0.0240	4
	97F8068	45.0	0.0235	5
	97F8069	50.0	0.0222	5
	97F8070	55.0	0.0210	5
	97F8071	60.0	0.0175	5
	97F8072	65.0	0.0169	5
	97F8073	70.0	0.0207	6

The 97F8000 Series of capacitors may be used in AC applications where the voltage waveform is non-sinusoidal. This Application Note is provided to assist in the correct use of the capacitors where higher frequency harmonic currents are present. If you need further assistance please contact Regal-Beloit's Capacitors Operation through your normal sales channel.

Higher frequency currents are commonly encountered in the filter circuits of Static Power Converters. These frequencies range from 180 to 1500 Hz for a 60 Hz system in various combinations of the odd harmonics depending on the type of converter. Generally, there are not significant harmonic currents above the 25th harmonic.

These capacitors can carry a total current of up to 15 amperes RMS (fundamental plus harmonics). The Equivalent Series Resistance (ESR) for each Catalog Number is shown in the ESR tables on this page. This value may be used to calculate the expected watts loss for a particular application. The user must determine the total RMS current (fundamental plus harmonics) for the application. The watts loss is then calculated using the equation:

$$W = I^2 \times \text{ESR} \quad I = \text{Total RMS current} \quad \text{ESR} = \text{Value from ESR Tables}$$

The calculated watts from this equation must not exceed the allowable watts loss shown on the curve corresponding to the particular capacitor. Two sets of curves are shown, one for natural circulation and one for forced air circulation.

NOTES:

- (1) In no case should the **total RMS current of 15 amperes** be exceeded for any of these capacitors
- (2) Running the capacitors at case temperatures above 70°C will have a significant effect on expected life. (See chart G-1 on page 11).
- (3) Running the capacitors at voltages above the nominal rated voltage will also results in significantly reduced life. (See chart G-2 on page 12).

ALLOWABLE WATTS LOSS – Natural Circulation

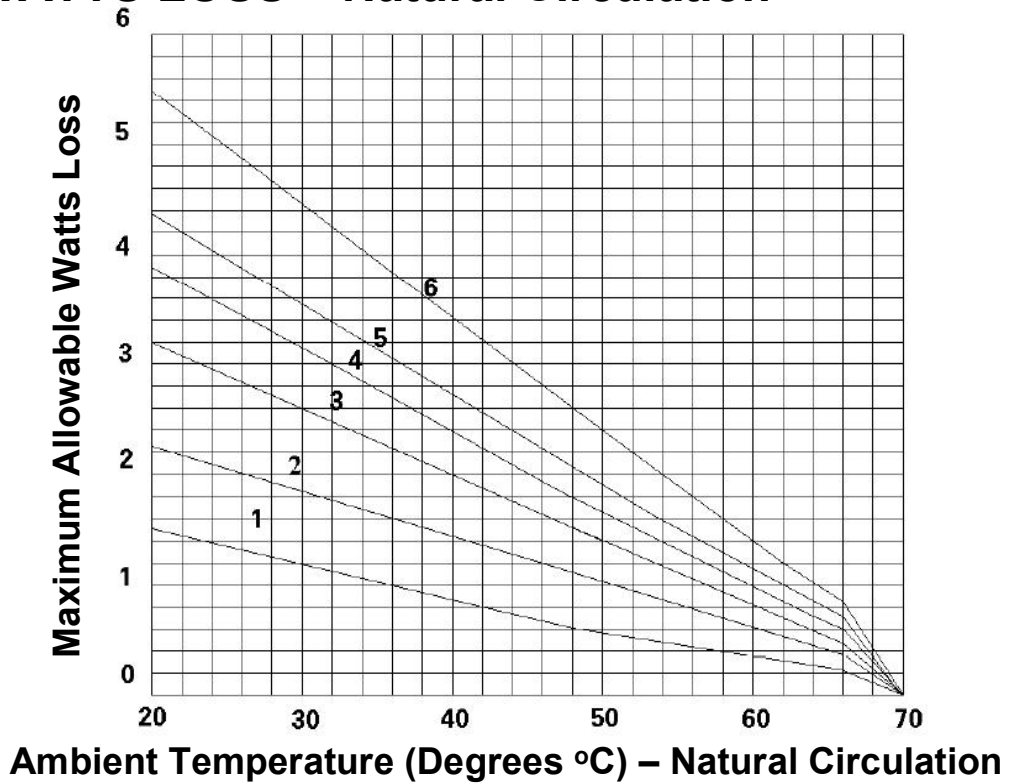

ALLOWABLE WATTS LOSS – Forced Circulation

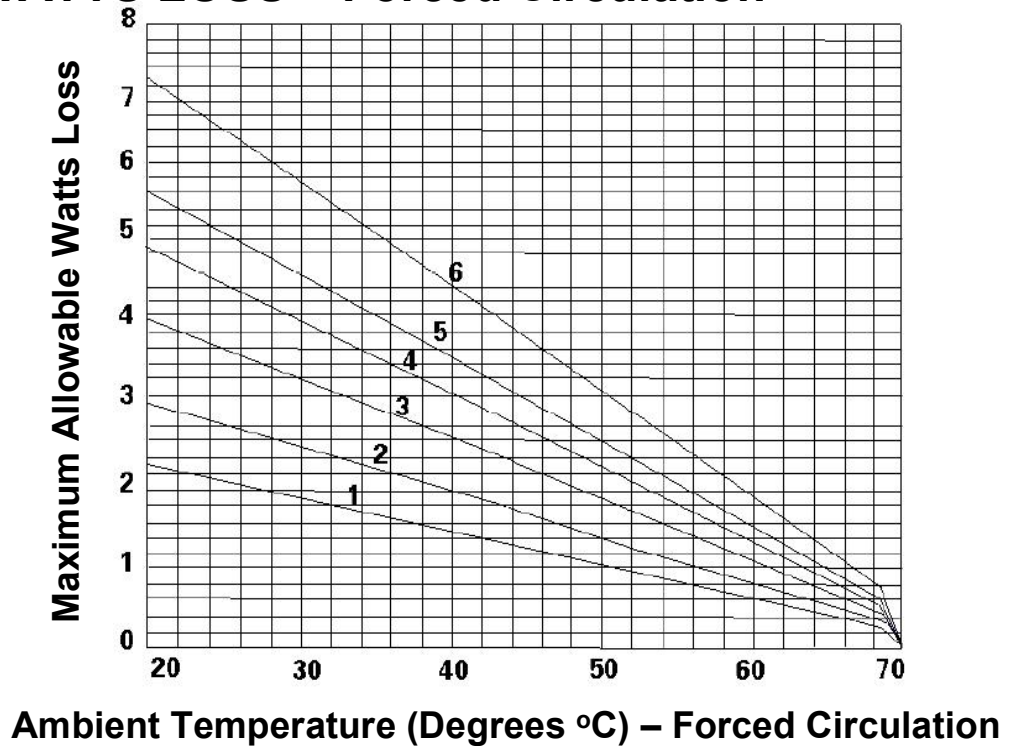

LIFE vs. TEMPERATURE

CHART G-1

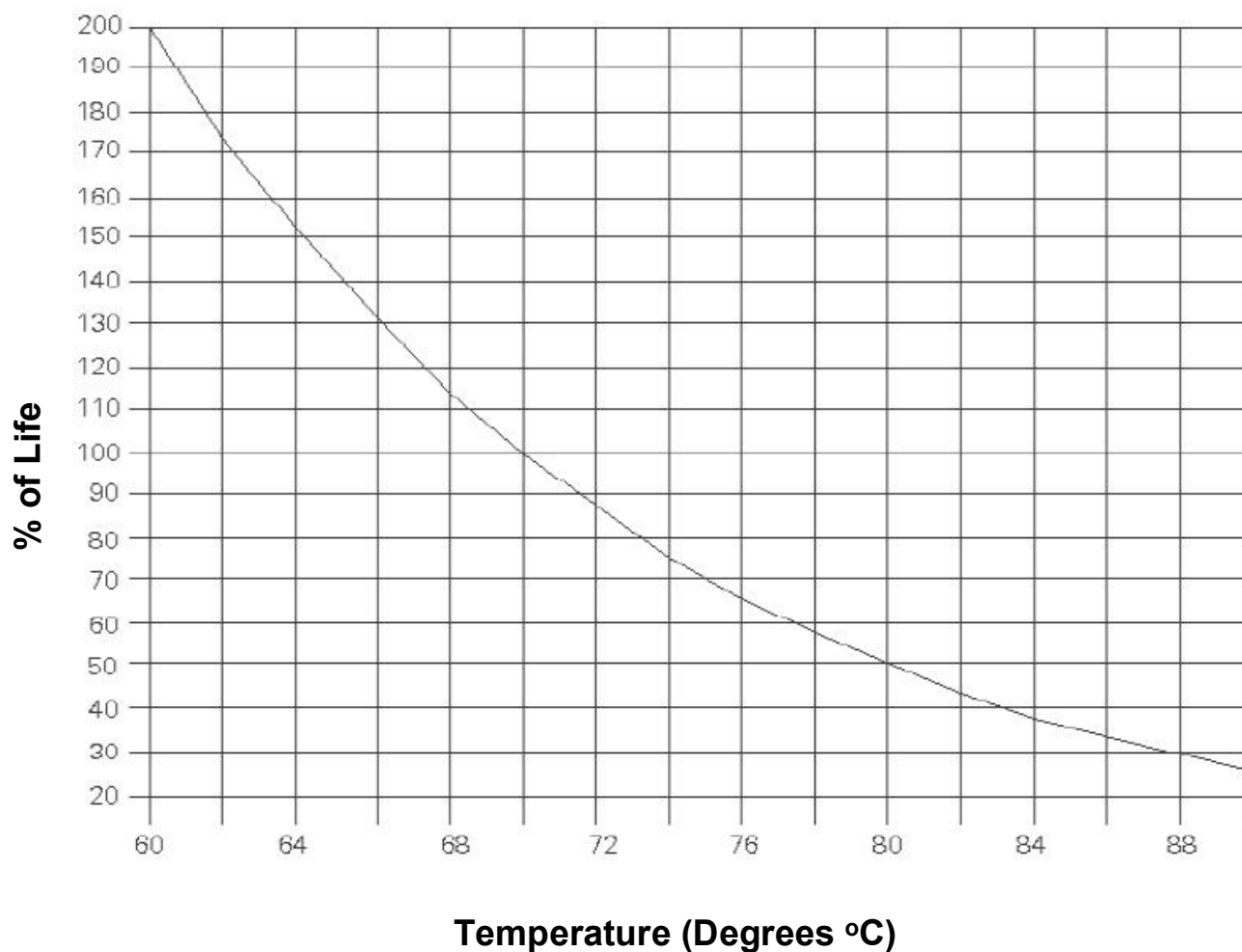

LIFE vs. VOLTAGE

CHART G-2

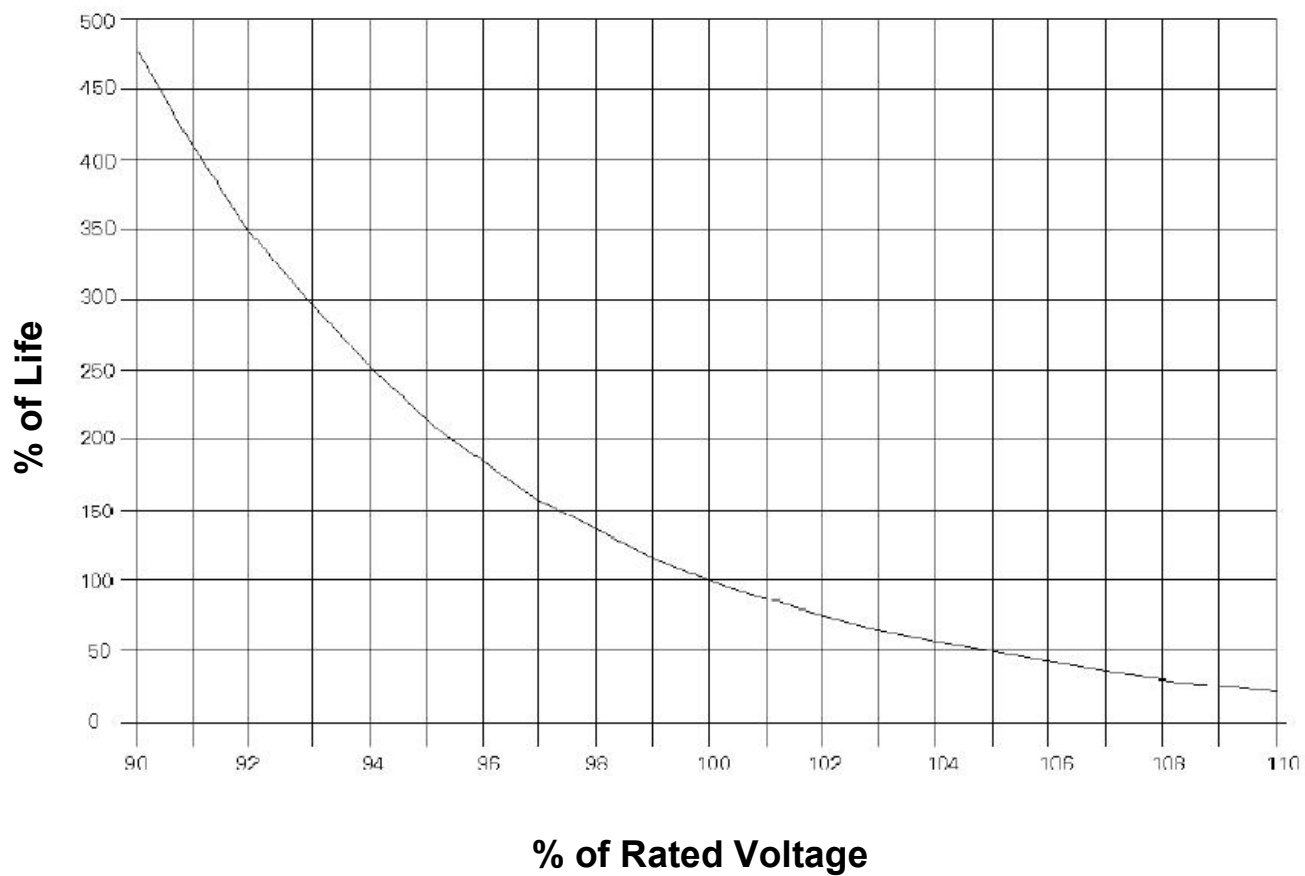

% CAPACITANCE vs. TEMPERATURE

CHART E-3

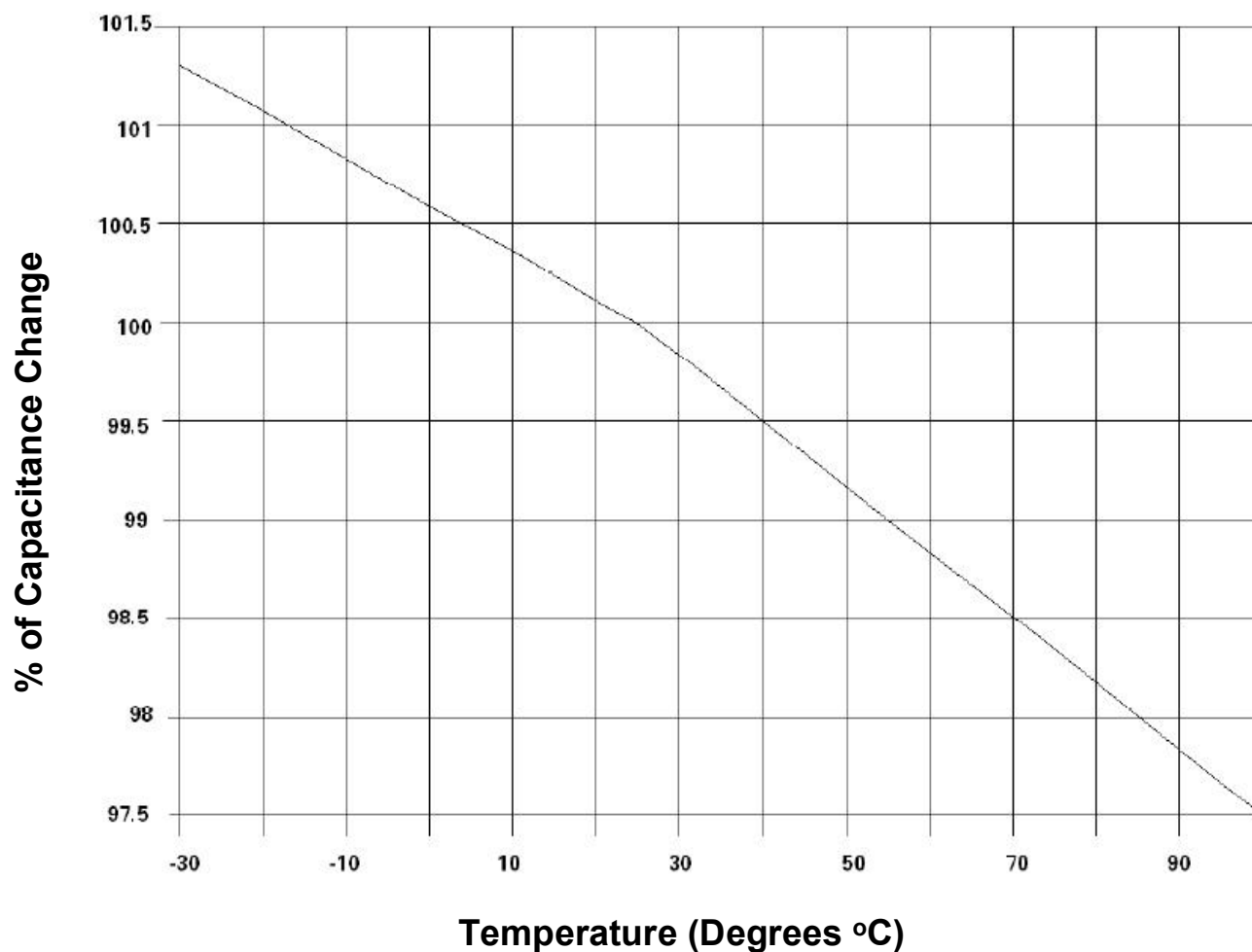

This series of GEM III is **designed specifically for general purpose AC applications in power supplies, UPS, and power conversion equipment.** Application Data is provided starting on page 16 that gives the Equivalent Series Resistance (ESR) for each unit. This allows the user to calculate the losses for each design / application and to ensure that they are kept within the permissible limits. **Any questions** regarding the suitability of a capacitor for a particular application may be referred to Regal-Beloit Engineers by **contacting your Regal-Beloit sales representative.**

SPECIFICATIONS:

Available Capacitance Range:	1.5 to 45 μ F
Capacitance Tolerance:	\pm 6%
Capacitance Variation with Temperature:	See Chart E-3 on page 20.
Rated Voltage:	See Rating Tables. Rating is the 60Hz RMS voltage for a sinusoidal waveform. For other waveforms refer to the Application Note on page 16.
Leakage Current:	30 μ A maximum
Frequency:	50/60 Hz. For higher frequencies refer to the Application Note on page 17.
Operating Temperature:	-40°C to +70°C
Storage Temperature:	-40°C to +90°C
Operating Life:	60,000 hours with 94% survival (In accordance with the EIA-456 Industry Standard)
Dissipation Factor:	0.1% maximum
Case Material/Finish:	Unpainted Aluminum Case, Tin Plated Steel Cover. Contact Regal-Beloit if material/finish to meet UL outdoor standards is required.
Terminations:	'Combo' terminal: 0.250" x 0.031" quick connect blades
Dielectric Fluid:	Dielektrol VI
Internal Protection:	UL recognized Pressure Sensitive Interrupter. See Ratings Table for Regal-Beloit's UL Code Number listed under Regal-Beloit's UL File E7793 (N). For UL submittals with these capacitors, use the RBC 'Pxxx' number not the Catalog Number. The corresponding generic UL designation that includes the Available Faults Current (AFC) rating is given below. All these capacitors are capable of interrupting available fault currents of up to 10,000 amperes.

Case Style	RBC Code	Generic UL Code
A	P961	A10000AFC
B	P962	B10000AFC
C	P963	C10000AFC
D	P964	D10000AFC

Gen Purpose AC Capacitors – GEM III

Single Ratings – 1 Section

Voltage (VAC)	Capacitance (µF)	Catalog Number	Case Style	Base Size (in.)	Can Type	Height C (in.)	UL Code
600	1.5	97F8240	A	1.25	Oval	2.12	P961
	2.0	97F8241	A	1.25	Oval	2.12	P961
	2.5	97F8242	A	1.25	Oval	2.88	P961
	3.0	97F8243	A	1.25	Oval	2.88	P961
	4.0	97F8244	A	1.25	Oval	2.88	P961
	5.0	97F8245	A	1.25	Oval	3.88	P961
	6.0	97F8246	A	1.25	Oval	3.88	P961
	7.0	97F8247	A	1.25	Oval	4.75	P961
	8.0	97F8248	A	1.25	Oval	4.75	P961
	10.0	97F8249	B	1.50	Oval	3.88	P962
	12.0	97F8250	B	1.50	Oval	3.88	P962
	15.0	97F8251	B	1.50	Oval	3.88	P962
	18.0	97F8252	B	1.50	Oval	4.75	P962
	20.0	97F8253	B	1.50	Oval	4.75	P962
	25.0	97F8254	C	1.75	Oval	4.75	P963
	30.0	97F8255	D	2.00	Oval	3.88	P964
	35.0	97F8256	D	2.00	Oval	4.75	P964
	40.0	97F8257	D	2.00	Oval	4.75	P964
45.0	97F8258	D	2.00	Oval	4.75	P964	

Case Style A, B, C, and D

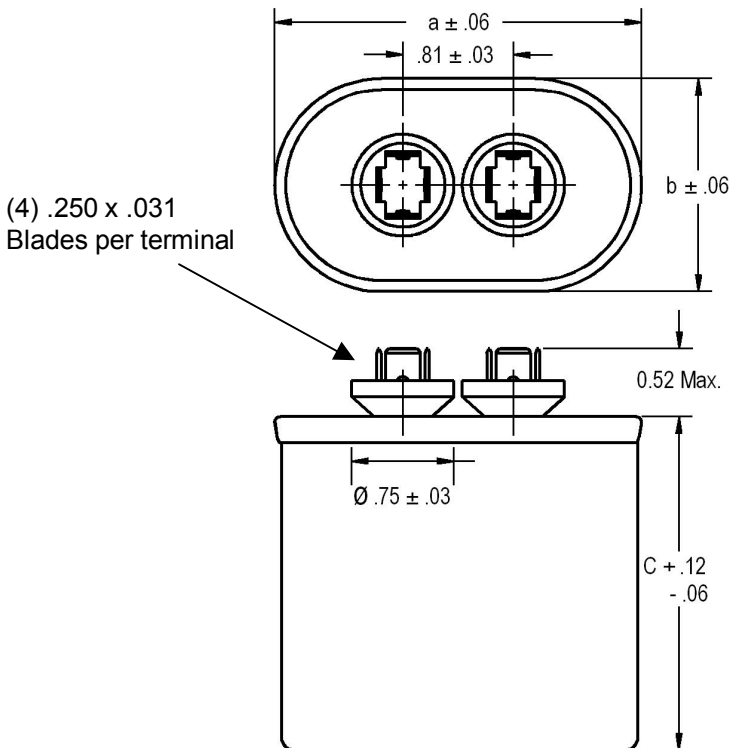

Case Style	a	b
A	2.16	1.31
B	2.69	1.56
C	2.91	1.91
D	3.66	1.97

*It is **Regal-Beloit's goal** to serve you with the **most cost effective** and **highest quality capacitor** designs. Standardization to the catalog type shown is a major program at Regal-Beloit. However, Regal-Beloit remains sensitive to your needs and requirements, and **will continue to offer the above ratings (and more) in case configurations to meet your application(s).**

Gen Purpose AC Capacitors – GEM III

Application Notes – 97F8200 Series – 600 VAC

ESR Values for 97F8200 Series – Curve Numbers refer to Graphs on Page 17.

Voltage (VAC)	Catalog Number	Capacitance (µF)	ESR (ohms)	Curve Number
600	97F8240	1.5	0.1277	1
	97F8241	2.0	0.0971	1
	97F8242	2.5	0.0984	2
	97F8243	3.0	0.0831	2
	97F8244	4.0	0.0639	2
	97F8245	5.0	0.0723	3
	97F8246	6.0	0.0615	3
	97F8247	7.0	0.0739	4
	97F8248	8.0	0.0657	4
	97F8249	10.0	0.0404	4
	97F8250	12.0	0.0366	4
	97F8251	15.0	0.0309	4
	97F8252	18.0	0.0361	5
	97F8253	20.0	0.0334	5
	97F8254	25.0	0.0294	5
	97F8255	30.0	0.0220	5
	97F8256	35.0	0.0258	6
	97F8257	40.0	0.0240	6
97F8258	45.0	0.0225	6	

The 97F8200 Series of capacitors may be used in AC applications where the voltage waveform is non-sinusoidal. This Application Note is provided to assist in the correct use of the capacitors where higher frequency harmonic currents are present. If you need further assistance please contact Regal-Beloit's Capacitors Operation through your normal sales channel.

Higher frequency currents are commonly encountered in the filter circuits of Static Power Converters. These frequencies range from 180 to 1500 Hz for a 60 Hz system in various combinations of the odd harmonics depending on the type of converter. Generally, there are not significant harmonic currents above the 25th harmonic.

These capacitors can carry a total current of up to 15 amperes RMS (fundamental plus harmonics). The Equivalent Series Resistance (ESR) for each Catalog Number is shown in the ESR tables on this page. This value may be used to calculate the expected watts loss for a particular application. The user must determine the total RMS current (fundamental plus harmonics) for the application. The watts loss is then calculated using the equation:

$$W = I^2 \times ESR \quad I = \text{Total RMS current} \quad ESR = \text{Value from ESR Tables}$$

The calculated watts from this equation must not exceed the allowable watts loss shown on the curve corresponding to the particular capacitor. Two sets of curves are shown, one for natural circulation and one for forced air circulation.

NOTES:

- (1) In no case should the **total RMS current** of **15 amperes** be exceeded for any of these capacitors
- (2) Running the capacitors at case temperatures above 70°C will have a significant effect on expected life. (See chart G-1 on page 18).
- (3) Running the capacitors at voltages above the nominal rated voltage will also results in significantly reduced life. (See chart G-2 on page 19).

ALLOWABLE WATTS LOSS – Natural Circulation

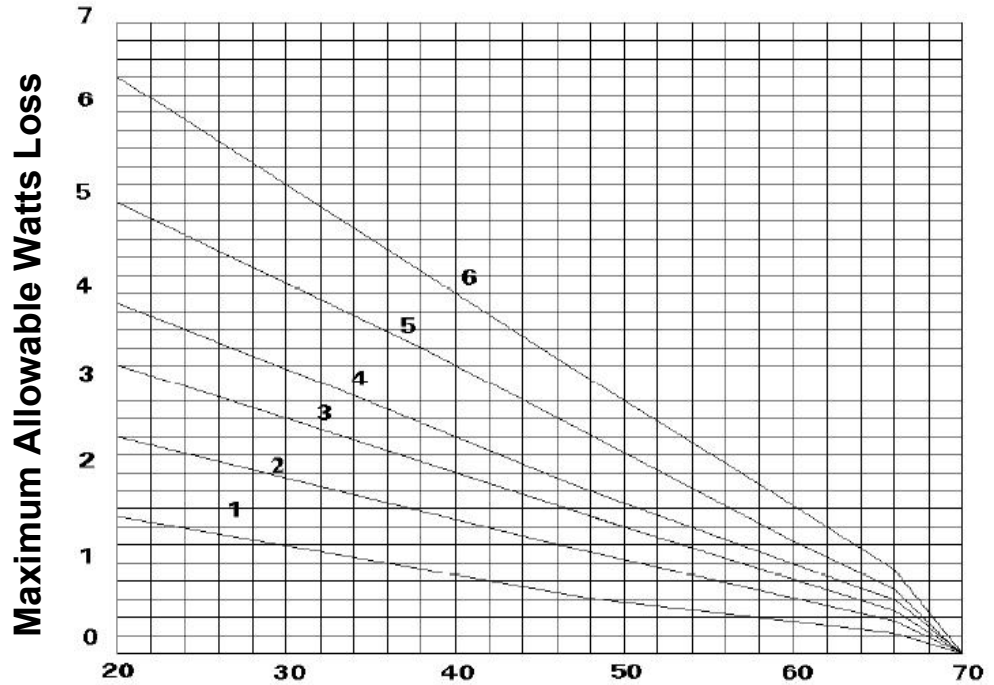

Ambient Temperature (Degrees °C) – Natural Circulation

ALLOWABLE WATTS LOSS – Forced Circulation

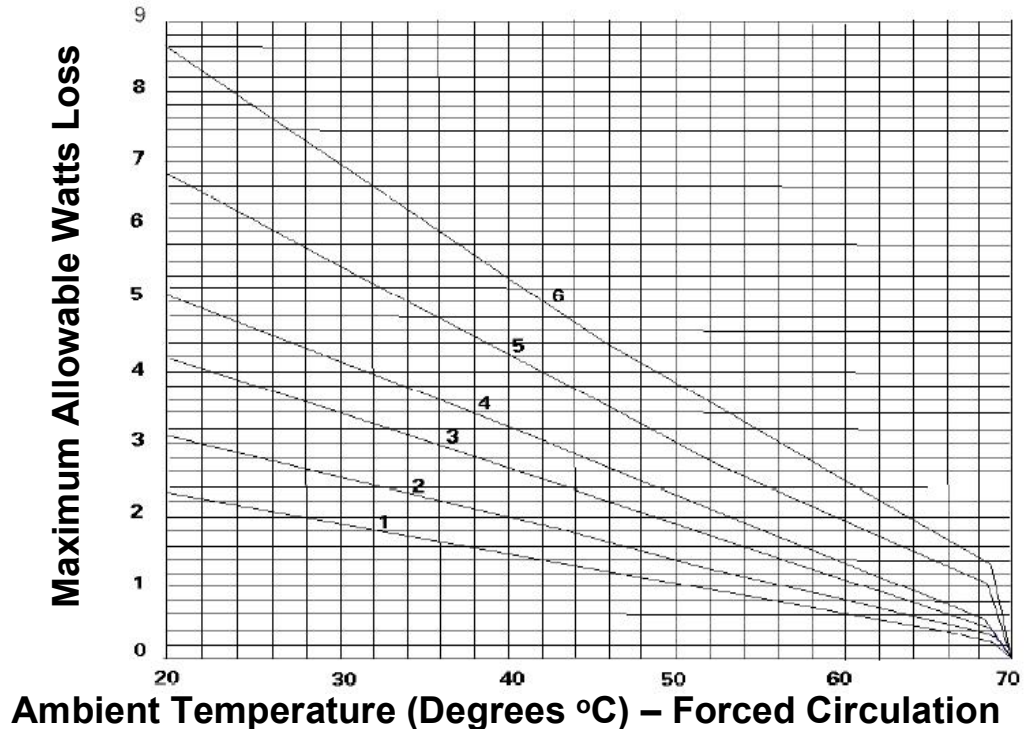

Ambient Temperature (Degrees °C) – Forced Circulation

LIFE vs. TEMPERATURE

CHART G-1

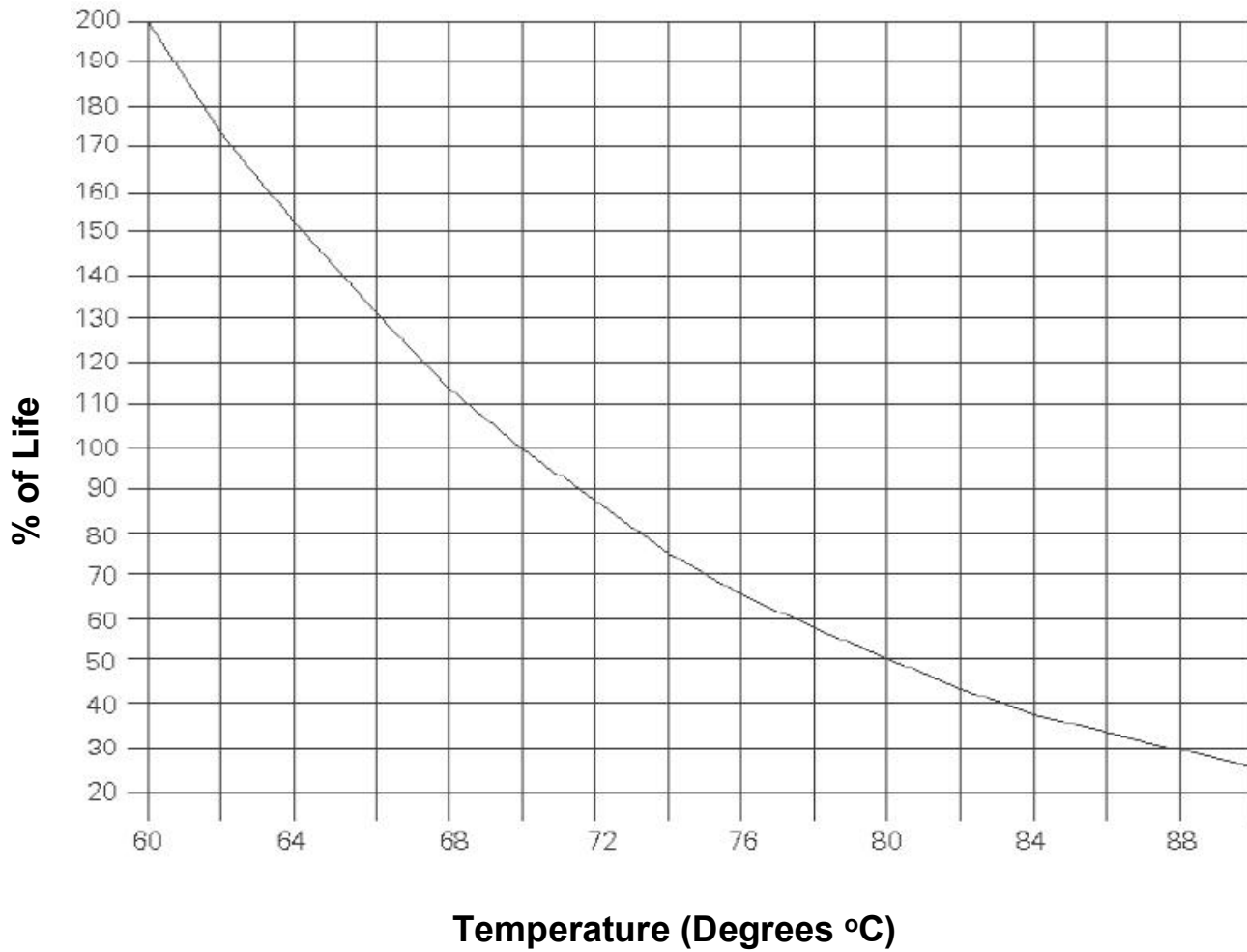

LIFE vs. VOLTAGE

CHART G-2

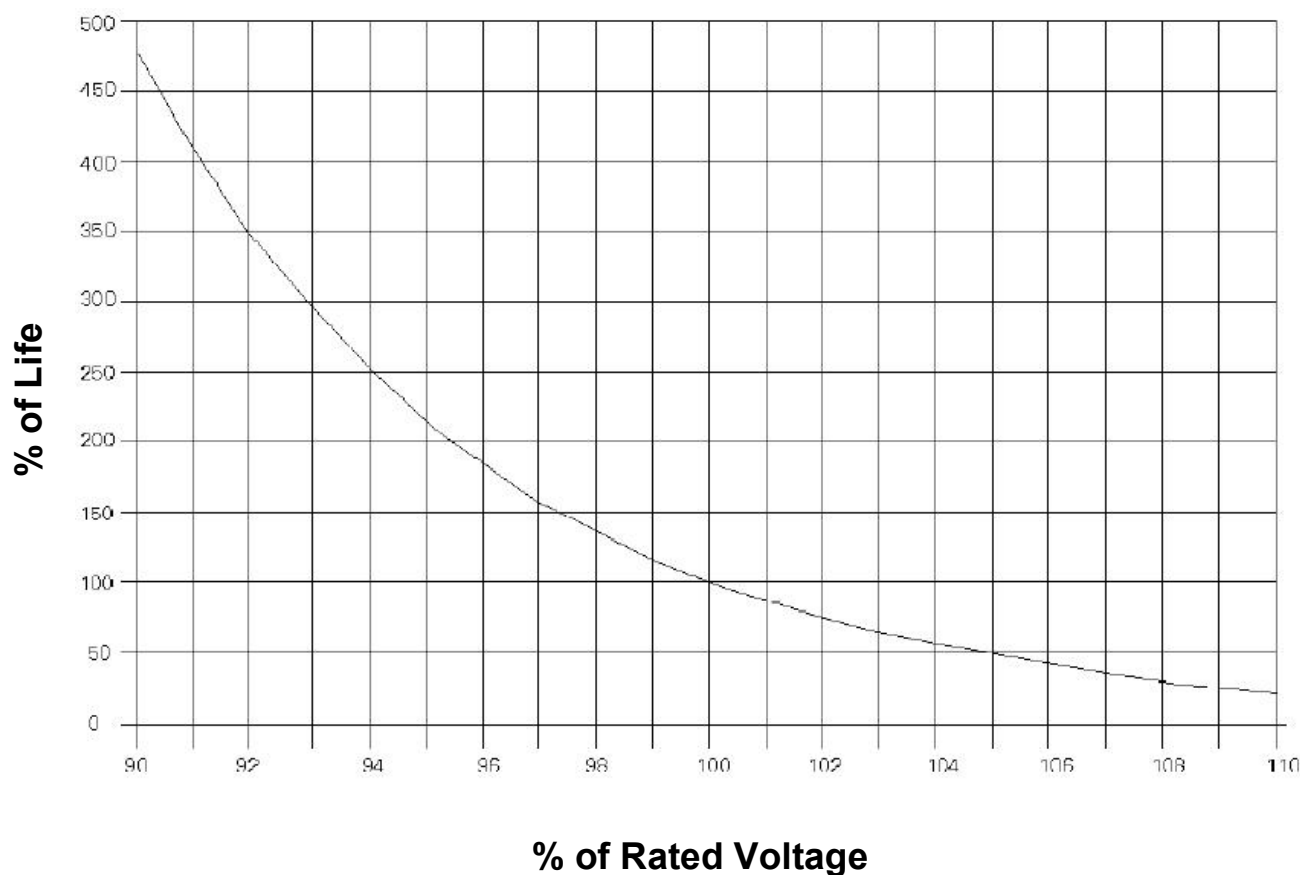

% CAPACITANCE vs. TEMPERATURE

CHART E-3

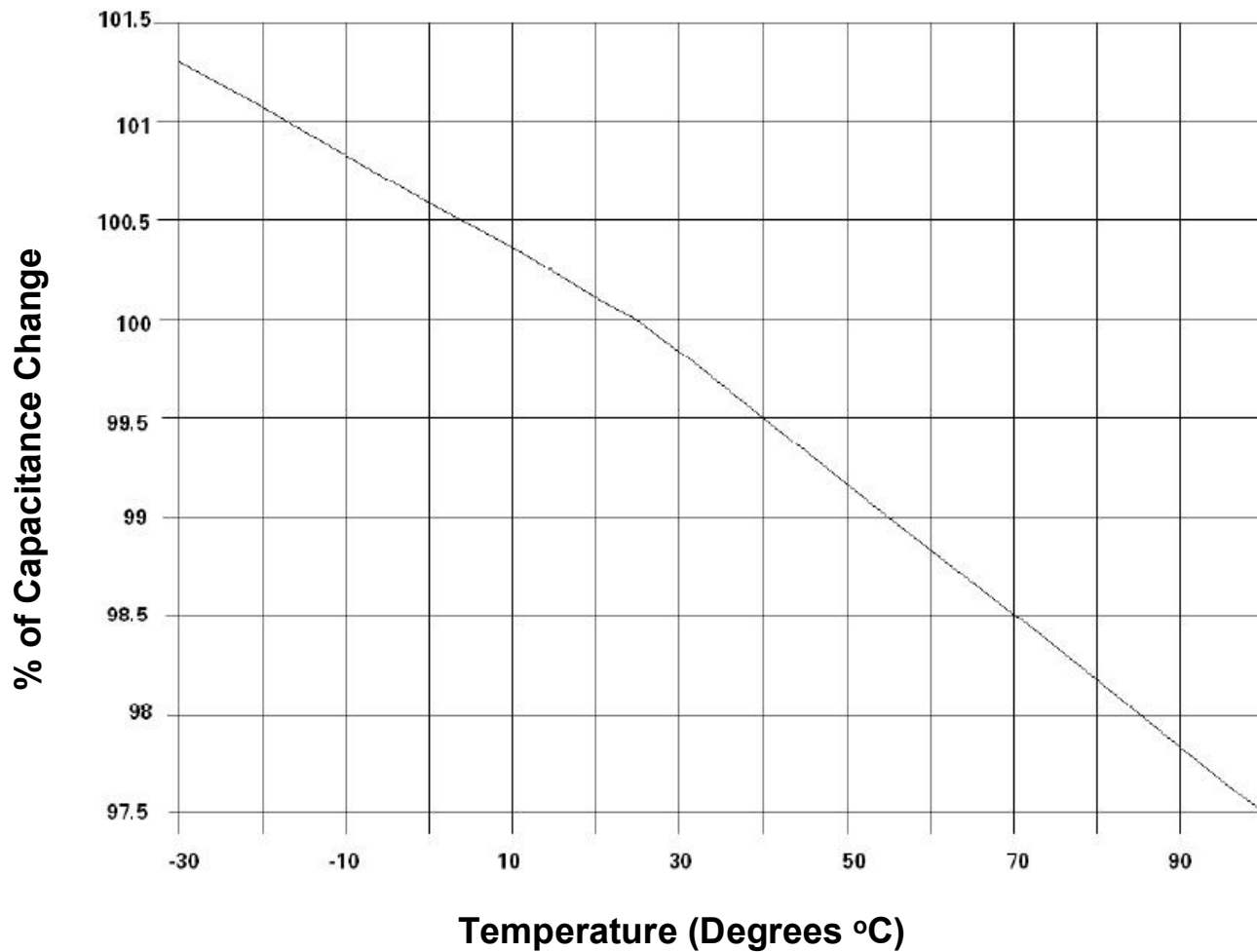

Gen Purpose AC Capacitors – GEM III

660 VAC (Series Section)

This series of GEM III is **designed specifically for general purpose applications in power supplies, UPS, and power conversation equipment.** Application Data is provided starting on page 23 that gives the Equivalent Series Resistance (ESR) for these units. This allows the user to calculate the losses for each design / application and to ensure that they are kept within the permissible limits. **Any questions** regarding the suitability of a capacitor for a particular application may be referred to Regal-Beloit Engineers by **contacting your Regal-Beloit sales representative.**

SPECIFICATIONS:

- Available Capacitance Range:** 2 to 45 μ F
- Capacitance Tolerance:** \pm 6%
- Capacitance Variation with Temperature:** See Chart E-3 on page 27.
- Rated Voltage:** See Rating Tables. Rating is the 60Hz RMS voltage for a sinusoidal waveform. For other waveforms refer to the Application Note on page 23.
- Leakage Current:** 30 μ A maximum
- Frequency:** 50/60 Hz. For higher frequencies refer to the Application Note on page 24.
- Operating Temperature:** -40°C to +70°C
- Storage Temperature:** -40°C to +90°C
- Operating Life:** 60,000 hours with 94% survival
(In accordance with the EIA-456 Industry Standard)
- Dissipation Factor:** 0.1% maximum
- Case Material/Finish:** Unpainted Aluminum Case, Tin Plated Steel Cover.
- Terminations:** ‘Combo’ terminal: 0.250” x 0.031” quick connect blades
- Dielectric Fluid:** Dielektrol VI
- Internal Protection:** UL recognized Pressure Sensitive Interrupter. See Ratings Table for Regal-Beloit’s UL Code Number listed under Regal-Beloit’s UL File E7793 (N). For UL submittals with these capacitors, use the RBC ‘Pxxx’ number not the Catalog Number. The corresponding generic UL designation that includes the Available Faults Current (AFC) rating is given below. All these capacitors are capable of interrupting available fault currents of up to 1,000 amperes.

Case Style	RBC Code	Generic UL Code
A	P851	A1000AFC
B	P852	B1000AFC
C	P853	C1000AFC



Gen Purpose AC Capacitors – GEM III

Single Ratings – 1 Section

Voltage (VAC)	Capacitance (μF)	Catalog Number	Case Style	Base Size (in.)	Can Type	Height C (in.)	UL Code
660	2.0	27L6095	A	1.25	Oval	3.88	P851
	2.5	27L6093	A	1.25	Oval	3.88	P851
	3.0	27L6094	A	1.25	Oval	3.88	P851
	4.0	27L6012	A	1.25	Oval	3.88	P851
	5.0	27L6013	A	1.25	Oval	3.88	P851
	6.0	27L6014	A	1.25	Oval	4.75	P851
	7.0	27L6015	A	1.25	Oval	4.75	P851
	8.0	27L6016	A	1.25	Oval	4.75	P851
	10.0	27L6017	B	1.50	Oval	3.88	P852
	12.0	27L6018	B	1.50	Oval	4.75	P852
	15.0	27L6073	C	1.75	Oval	4.75	P853
	18.0	27L6089	D	2.00	Oval	3.88	P854
	20.0	27L6082	D	2.00	Oval	4.75	P854
	25.0	27L6022	D	2.00	Oval	4.75	P854
30.0	27L6023	D	2.00	Oval	4.75	P854	

Case Style A, B, C, and D

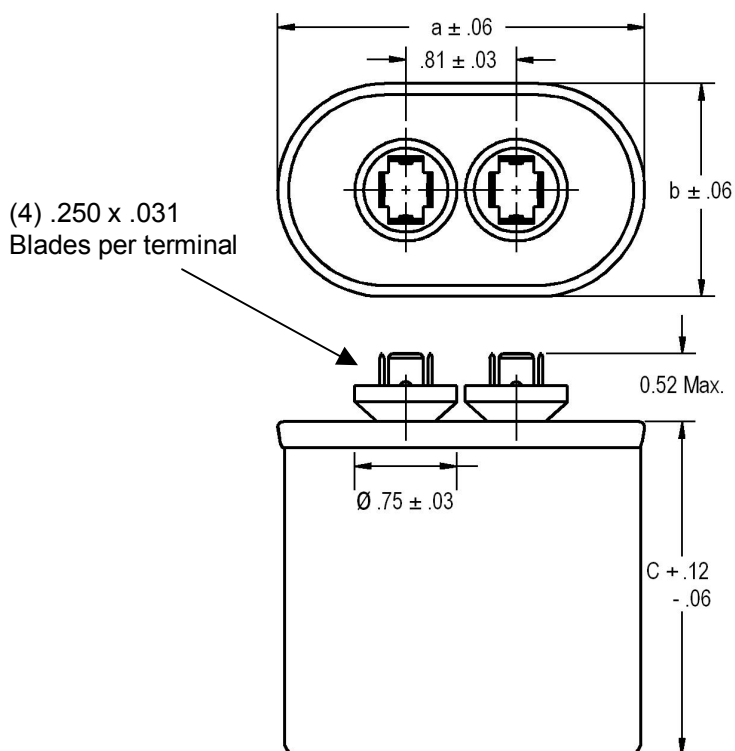

Case Style	a	b
A	2.16	1.31
B	2.69	1.56
C	2.91	1.91
D	3.66	1.97

*It is **Regal-Beloit's goal** to serve you with the **most cost effective** and **highest quality capacitor** designs. Standardization to the catalog type shown is a major program at Regal-Beloit. However, Regal-Beloit remains sensitive to your needs and requirements, and **will continue to offer the above ratings (and more) in case configurations to meet your application(s).**

Gen Purpose AC Capacitors – GEM III

Application Notes – 27L Series – 660 VAC

ESR Values for 27L Series – Curve Numbers refer to Graphs on Page 24.

Voltage (VAC)	Catalog Number	Capacitance (µF)	ESR (ohms)	Curve Number
660	27L6095	2.0	0.0971	1
	27L6093	2.5	0.0984	2
	27L6094	3.0	0.0831	2
	27L6012	4.0	0.0639	2
	27L6013	5.0	0.0723	2
	27L6014	6.0	0.0615	3
	27L6015	7.0	0.0739	3
	27L6016	8.0	0.0657	4
	27L6017	10.0	0.0404	4
	27L6018	12.0	0.0366	4
	27L6073	15.0	0.0309	4
	27L6089	18.0	0.0361	4
	27L6082	20.0	0.0334	5
	27L6022	25.0	0.0294	5
	27L6023	30.0	0.0220	5

The 27L Series of capacitors may be used in AC applications where the voltage waveform is non-sinusoidal. This Application Note is provided to assist in the correct use of the capacitors where higher frequency harmonic currents are present. If you need further assistance please contact Regal-Beloit's Capacitors Operation through your normal sales channel.

Higher frequency currents are commonly encountered in the filter circuits of Static Power Converters. These frequencies range from 180 to 1500 Hz for a 60 Hz system in various combinations of the odd harmonics depending on the type of converter. Generally, there are not significant harmonic currents above the 25th harmonic.

These capacitors can carry a total current of up to 15 amperes RMS (fundamental plus harmonics). The Equivalent Series Resistance (ESR) for each Catalog Number is shown in the ESR tables on this page. This value may be used to calculate the expected watts loss for a particular application. The user must determine the total RMS current (fundamental plus harmonics) for the application. The watts loss is then calculated using the equation:

$$W = I^2 \times \text{ESR} \quad I = \text{Total RMS current} \quad \text{ESR} = \text{Value from ESR Tables}$$

The calculated watts from this equation must not exceed the allowable watts loss shown on the curve corresponding to the particular capacitor. Two sets of curves are shown, one for natural circulation and one for forced air circulation.

NOTES:

- (1) In no case should the **total RMS current** of **15 amperes** be exceeded for any of these capacitors
- (2) Running the capacitors at case temperatures above 70°C will have a significant effect on expected life. (See chart G-1 on page 25).
- (3) Running the capacitors at voltages above the nominal rated voltage will also results in significantly reduced life. (See chart G-2 on page 26).

ALLOWABLE WATTS LOSS – Natural Circulation

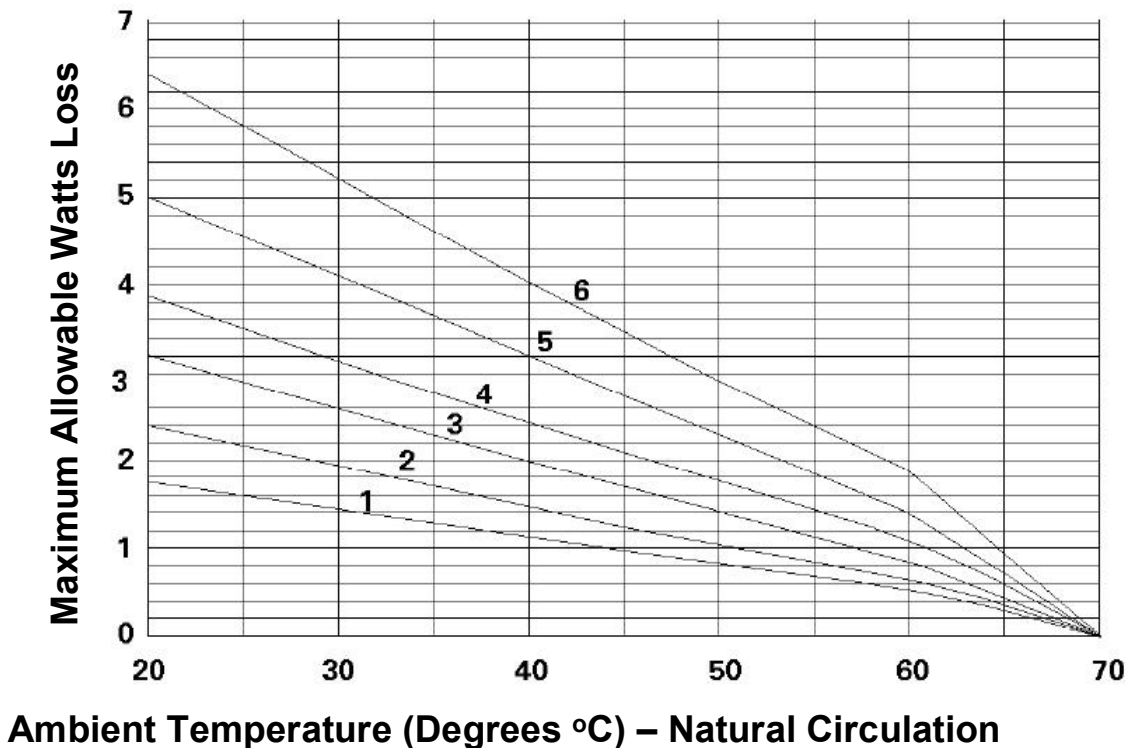

ALLOWABLE WATTS LOSS – Forced Circulation

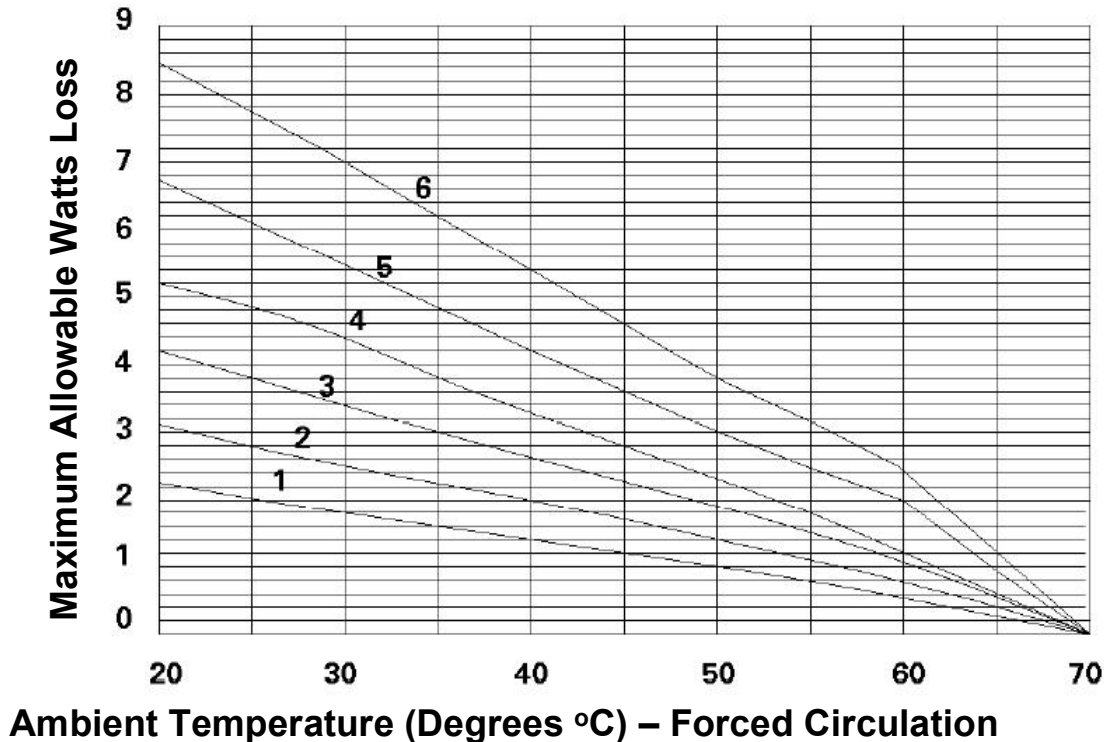

LIFE vs. TEMPERATURE

CHART G-1

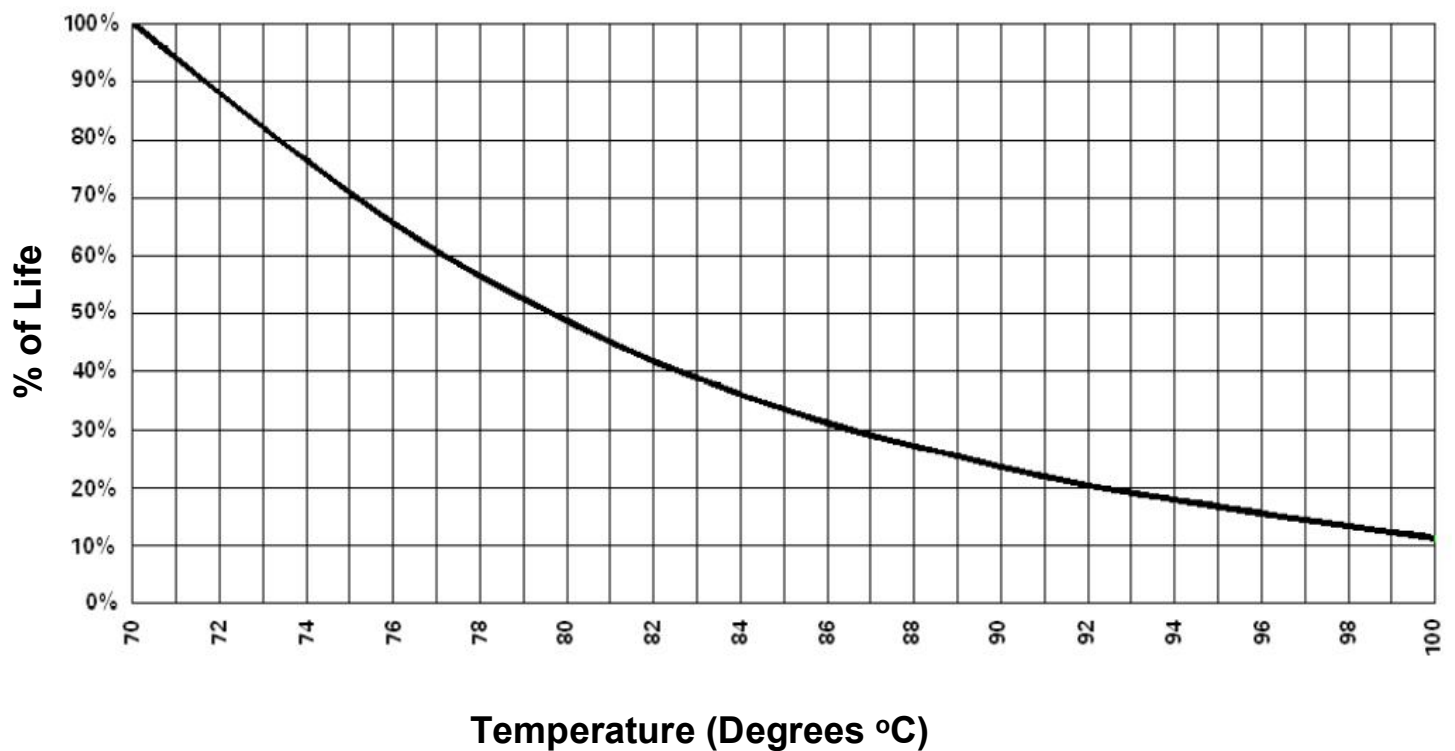

The above chart is intended as general reference only. Any indication of extended life by reducing temperature is in no way a guarantee of extended product life.

LIFE vs. VOLTAGE

CHART G-2

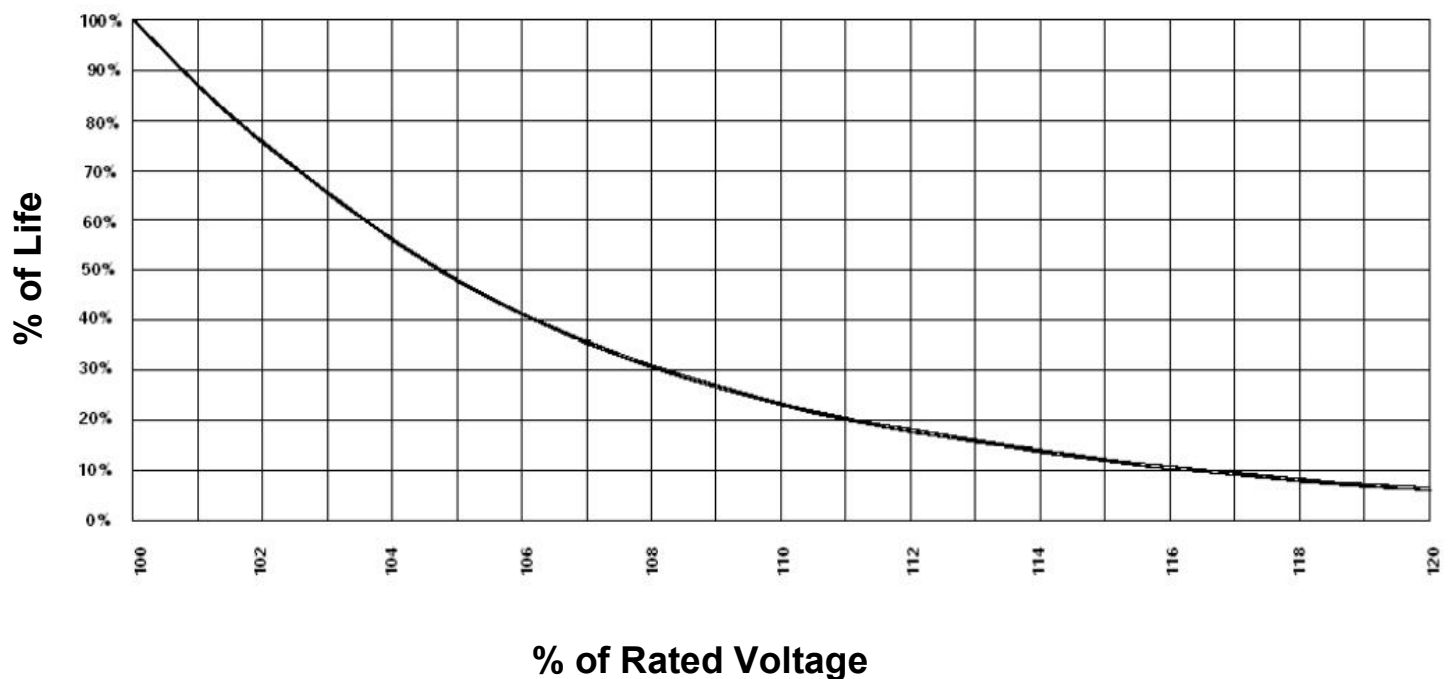

The above chart is intended as general reference only. Any indication of extended life by reducing voltage is in no way a guarantee of extended product life.

% CAPACITANCE vs. TEMPERATURE

CHART E-3

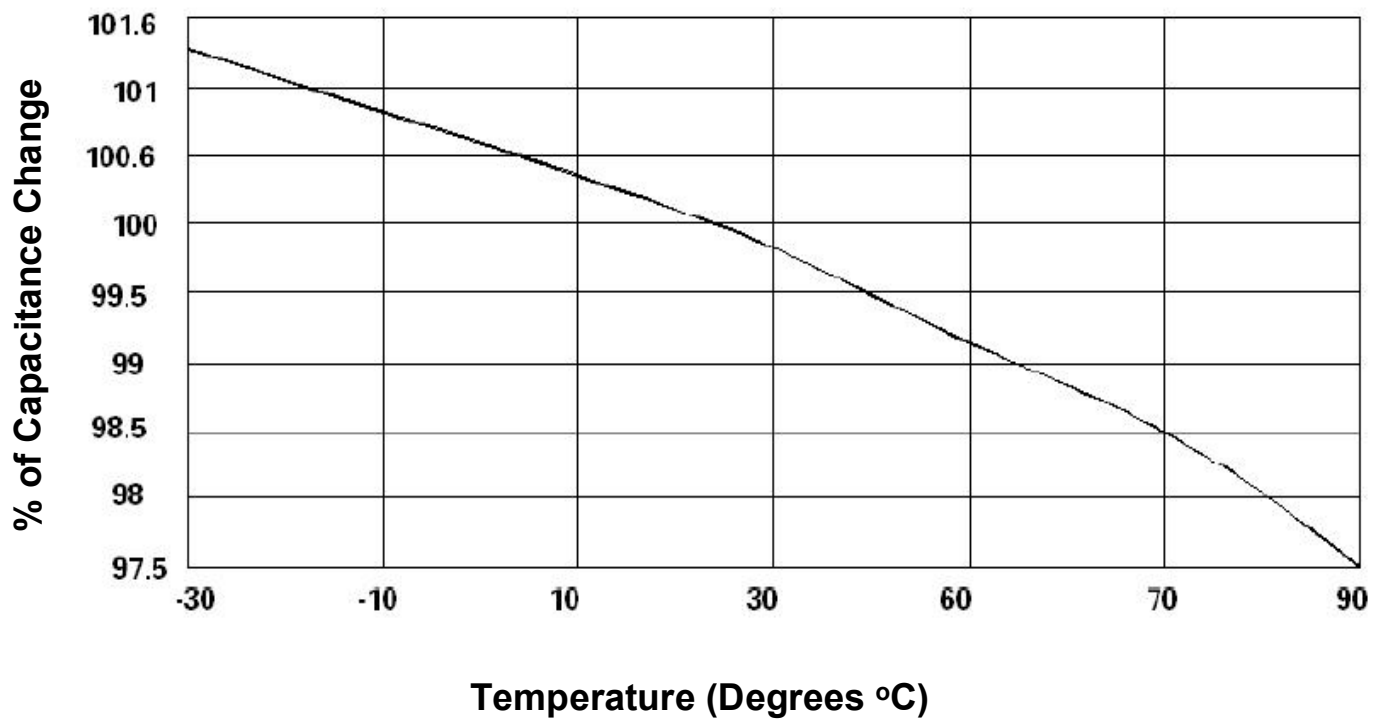

28 Gen Purpose AC/DC Capacitors – GEM III

1000 VDC Peak

This series of GEM III – dual rated AC/DC Capacitors is **designed specifically for applications such as AC/DC filters where harmonic frequencies greater than 60Hz are common.** These capacitors are typically used in DC filters at voltages above those served by electrolytic type construction. **Any questions** regarding the suitability of a capacitor for a particular application may be referred to Regal-Beloit Engineers through **contacting your Regal-Beloit sales representative.**

SPECIFICATIONS:

Available Capacitance Range:	3 to 50 μ F
Capacitance Tolerance:	\pm 6%
Capacitance Variation with Temperature:	\pm 5% from -40°C to +70°C
Rated Voltage:	See Rating Tables. Rating is the Max Peak DC Voltage.
Ripple Voltage:	The RMS ripple voltage should not exceed the following percentages of the rated voltage for these frequencies:

<u>Frequency</u>	<u>% of Rated Voltage</u>
60 Hz	44
120 Hz	30
400 Hz	12
1,000 Hz	8
10,000 Hz	0.6

Operating Temperature:	-30°C to +70°C
Storage Temperature:	-55°C to +70°C
Operating Life:	60,000 hours with 90% survival with proper derating.
Dissipation Factor:	0.3% maximum
Case Material/Finish:	Unpainted Aluminum Case, Tin Plated Steel Cover.
Terminations:	'Combo' terminal: 0.250" x 0.031" quick connect blades
Dielectric Fluid:	Dielektrol VI
Internal Protection:	UL recognized Pressure Sensitive Interrupter. See Ratings Table for Regal-Beloit's UL Code Number listed under Regal-Beloit's UL File E7793 (N). For UL submittals with these capacitors, use the RBC 'Pxxx' number not the Catalog Number. The corresponding generic UL designation that includes the Available Faults Current (AFC) rating is given below. All these capacitors are capable of interrupting available fault currents of up to 10,000 amperes.

Case Style	RBC Code	Generic UL Code
A	P921	A1000AFC
P	P965	P1000AFC
S	P968	S1000AFC
T	P969	T1000AFC

Gen Purpose AC/DC Capacitors – GEM III 29

Single Ratings – 1 Section

Voltage Rating	Capacitance (μF)	Catalog Number	Case Style	Base Size (in.)	Can Type	Height C (in.)
1000 VDC Peak (440 VAC)	3.0	97F5437	A	1.25	Oval	2.12
	4.0	97F5337	A	1.25	Oval	2.88
	5.0	97F5339	A	1.25	Oval	2.88
	6.0	97F5436	A	1.25	Oval	2.88
	7.5	97F9036	A	1.25	Oval	3.88
	10.0	97F5300	A	1.25	Oval	3.88
	12.5	97F5001	P	1.75	Round	2.88
	15.0	97F9037	P	1.75	Round	2.88
	17.5	97F9038	P	1.75	Round	3.88
	20.0	97F9039	P	1.75	Round	3.88
	25.0	97F9040	P	1.75	Round	4.75
	30.0	97F5023	P	1.75	Round	4.75
	35.0	97F9041	S	2.00	Round	4.75
	40.0	97F5116	S	2.00	Round	4.75
	45.0	97F5209	T	2.50	Round	3.88
	50.0	97F5211	T	2.50	Round	3.88

Case Style P, S, and T

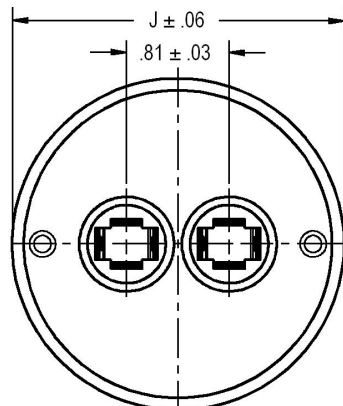

(4) .250 x .031 Blades per terminal except (3) on case style P

(4) .250 x .031 Blades per terminal

Case Style	K	J
P	1.75	1.88
S	2.00	2.12
T	2.50	2.62

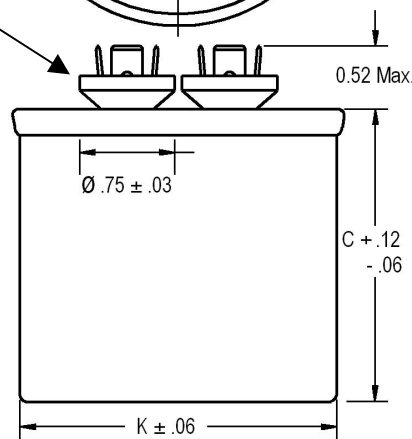

Case Style A

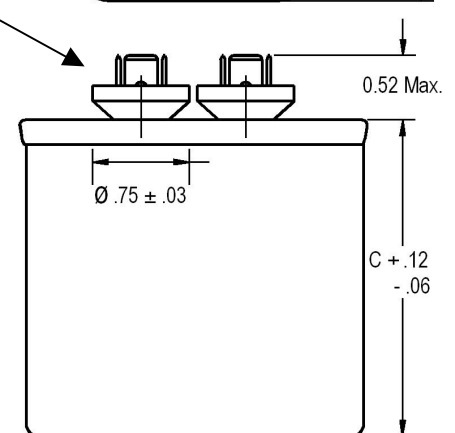
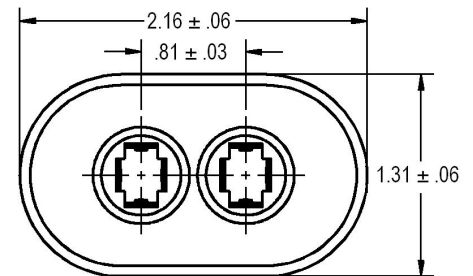

*It is Regal-Beloit's goal to serve you with the most cost effective and highest quality capacitor designs. Standardization to the catalog type shown is a major program at Regal-Beloit. However, Regal-Beloit remains sensitive to your needs and requirements, and will continue to offer the above ratings (and more) in case configurations to meet your application(s).

Cross Reference

600 VAC 26F6600 Series to NEW 660 VAC 27L Series

Series Name	Capacitance (µF)	Catalog Number	Case Style	Height Ht (in.)
Film / Paper (26F Series)	2.0	26F6618	A	2.12
	2.5	26F6619	A	2.12
	3.0	26F6620	A	2.38
	4.0	26F6621	A	3.12
	5.0	26F6622	A	3.50
	6.0	26F6623	A	4.25
	7.0	26F6624	A	4.50
	8.0	26F6625	A	5.50
	10.0	26F6626	C	3.88
	12.0	26F6627	C	4.50
	15.0	26F6628	C	5.50
	18.0	26F6629	C	6.75
	20.0	26F6634	D	6.25
	25.0	26F6665	D	7.25
30.0	26F6636	D	8.00	

Series Name	Capacitance (µF)	Catalog Number	Case Style	Height Ht (in.)	UL Code
GEM III (27L Series)	2.0	27L6095	A	3.88	P851
	2.5	27L6093	A	3.88	P851
	3.0	27L6094	A	3.88	P851
	4.0	27L6012	A	3.88	P851
	5.0	27L6013	A	3.88	P851
	6.0	27L6014	A	4.75	P851
	7.0	27L6015	A	4.75	P851
	8.0	27L6016	A	4.75	P851
	10.0	27L6017	B	3.88	P852
	12.0	27L6018	B	4.75	P852
	15.0	27L6073	C	4.75	P853
	18.0	27L6089	D	3.88	P854
	20.0	27L6082	D	4.75	P854
	25.0	27L6022	D	4.75	P854
	30.0	27L6023	D	4.75	P854

Film / Paper
(26F Series) Outline

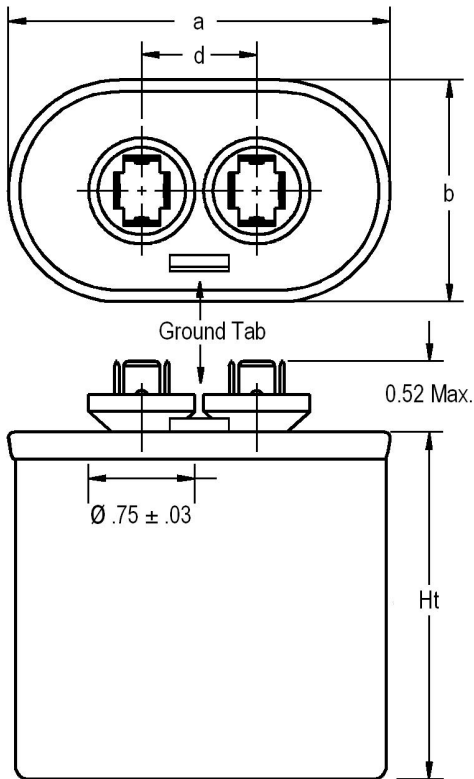

Case Style	a	b	d
A	2.16	1.31	0.81
B	2.69	1.56	0.81
C	2.91	1.91	0.81
D	3.66	1.97	0.81

GEM III
(27L Series) Outline

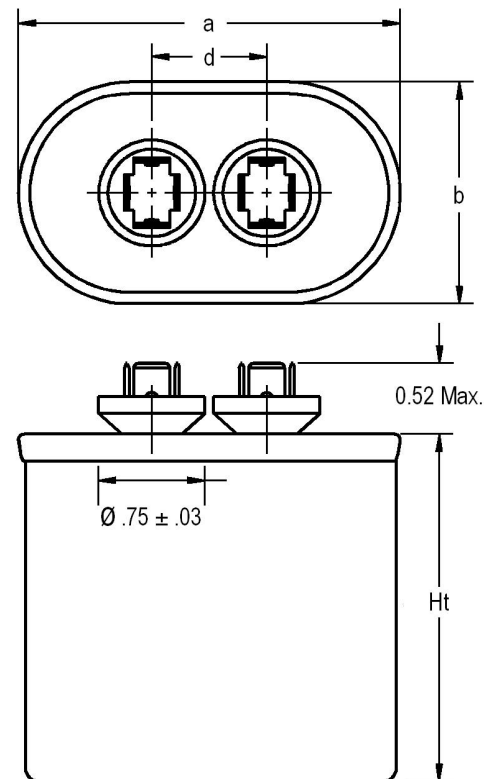

600 VAC 61L Series to NEW 660 VAC 27L Series

Series Name	Capacitance (µF)	Catalog Number	Case Style	Height Ht (in.)
GEM II (61L Series)	2.0	61L1271	A	2.12
	2.5	61L1280	A	2.88
	3.0	61L1272	A	2.88
	4.0	61L313	A	2.88
	5.0	61L1273	A	3.88
	6.0	61L1274	A	3.88
	7.0	61L316	A	3.88
	8.0	61L1275	A	4.75
	10.0	61L1286	B	3.88
	12.0	61L1276	B	4.75
	15.0	61L1289	B	5.75
	18.0	61L1277	B	5.75
	20.0	61L322	C	4.75
	25.0	61L323	C	5.75
30.0	61L324	D	5.75	

Series Name	Capacitance (µF)	Catalog Number	Case Style	Height Ht (in.)	UL Code
GEM III (27L Series)	2.0	27L6095	A	3.88	P851
	2.5	27L6093	A	3.88	P851
	3.0	27L6094	A	3.88	P851
	4.0	27L6012	A	3.88	P851
	5.0	27L6013	A	3.88	P851
	6.0	27L6014	A	4.75	P851
	7.0	27L6015	A	4.75	P851
	8.0	27L6016	A	4.75	P851
	10.0	27L6017	B	3.88	P852
	12.0	27L6018	B	4.75	P852
	15.0	27L6073	C	4.75	P853
	18.0	27L6089	D	3.88	P854
	20.0	27L6082	D	4.75	P854
	25.0	27L6022	D	4.75	P854
	30.0	27L6023	D	4.75	P854

GEM II
(61L Series) Outline

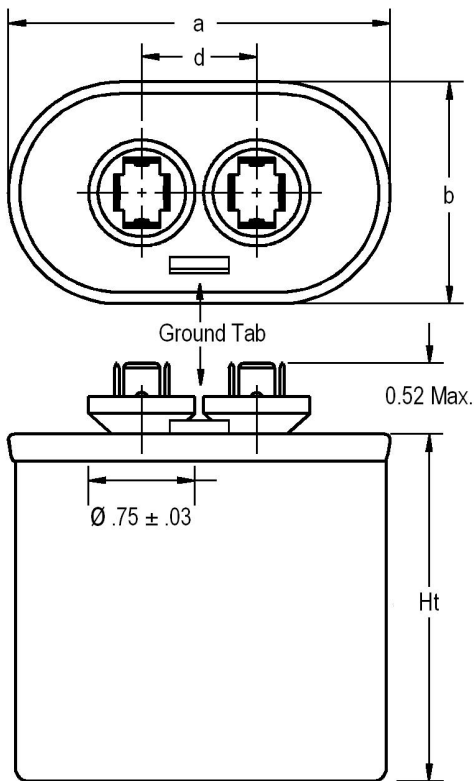

Case Style	a	b	d
A	2.16	1.31	0.81
B	2.69	1.56	0.81
C	2.91	1.91	0.81
D	3.66	1.97	0.81

GEM III
(27L Series) Outline

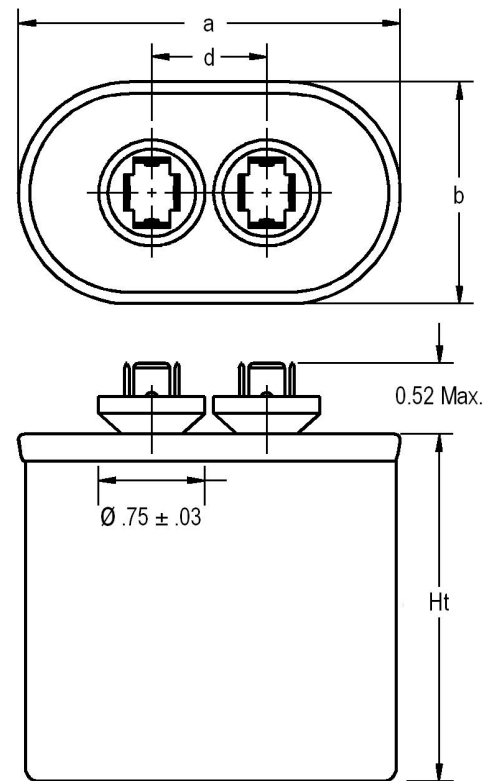

UNIVERSAL WRAP AROUND BRACKETS – Round Cases

Case Style	Bracket Part Number	a	b	c
P	M295A601631	1.75	1.12	1.31
S	M295A601632	2.00	1.25	1.44
T	M295A601633	2.50	1.50	1.69

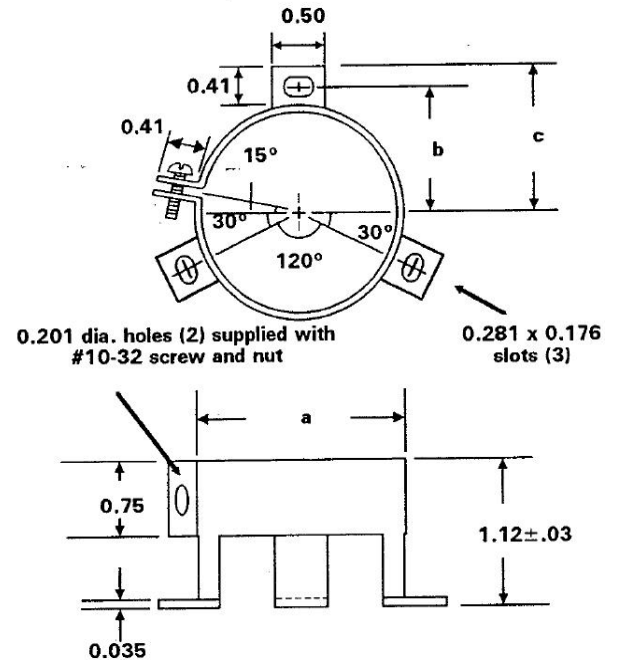

UNIVERSAL WRAP AROUND BRACKETS – Oval Cases

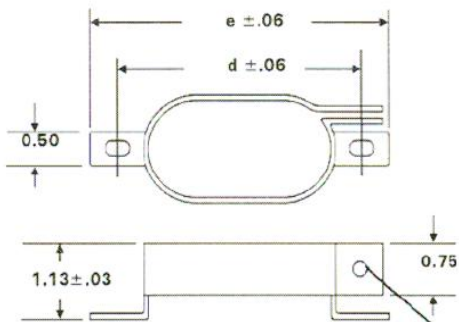

Case Style	Bracket Part Number	d	e
A	M128A2244AC21	2.69	3.13
B	M128A2244AB25	3.27	3.70
C	M128A2244AB22	3.44	3.88
D	M128A2244AB23	4.19	4.63

(2) .156 dia holes supplied with # 6-32 screw and nut

WRAP AROUND BRACKETS – Oval & Round Cases

Case Style	Bracket Part Number	d	e	w	t
A	M982706521	2.56	2.94	0.50	0.02
B	M982706531	3.06	3.50	0.63	0.02
C	M614A30161	3.31	3.81	0.75	0.03
D	M614A30151	4.06	4.56	0.75	0.03
P	M279A723524	2.50	2.88	0.75	0.04
S	M279A723522	2.75	3.12	0.75	0.04
T	M279A723523	3.25	3.62	0.75	0.04

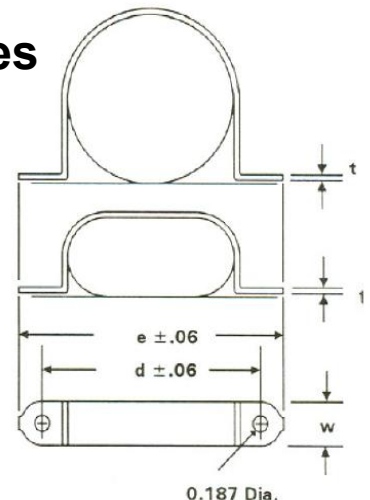

FOOTED BRACKETS – Oval & Round Cases

Case Height	Bracket Part Number
2.12	M302C920210
2.88	M302C920113
3.88	M302C920115
4.75	M302C920116
5.75	M302C920209

Case Style	d	e
A	2.56	3.00
B	3.13	3.56
C	3.38	3.81
D	4.13	4.56
P	2.33	2.76
S	2.57	3.00
T	3.07	3.50

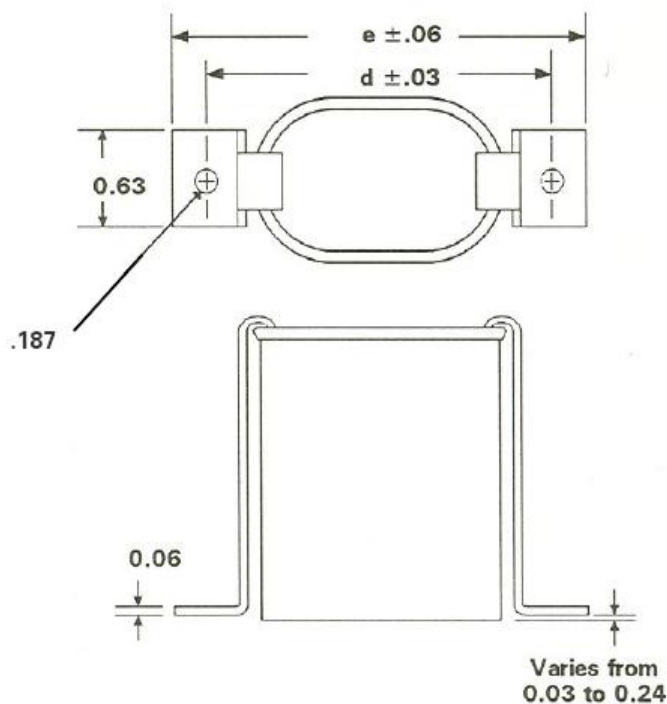

PROTECTIVE BOOT

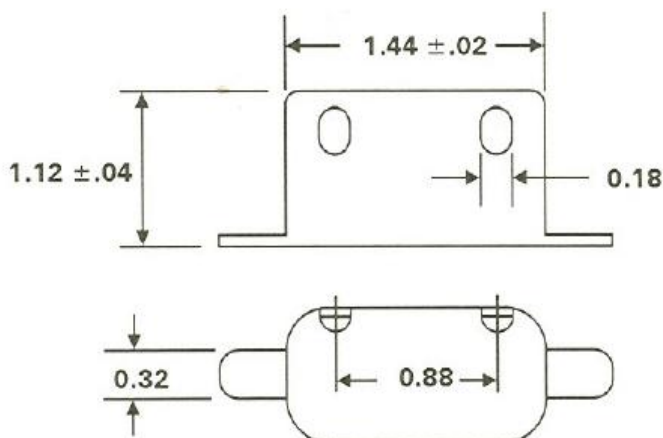

Boot Part Number	Temperature Rating
M614A52721	60°C
M178A374421	105°C

PROTECTIVE CAP

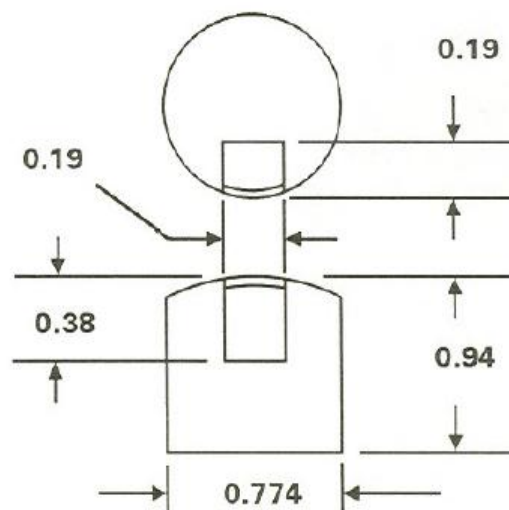

Cap Part Number	M115A155223
-----------------	-------------

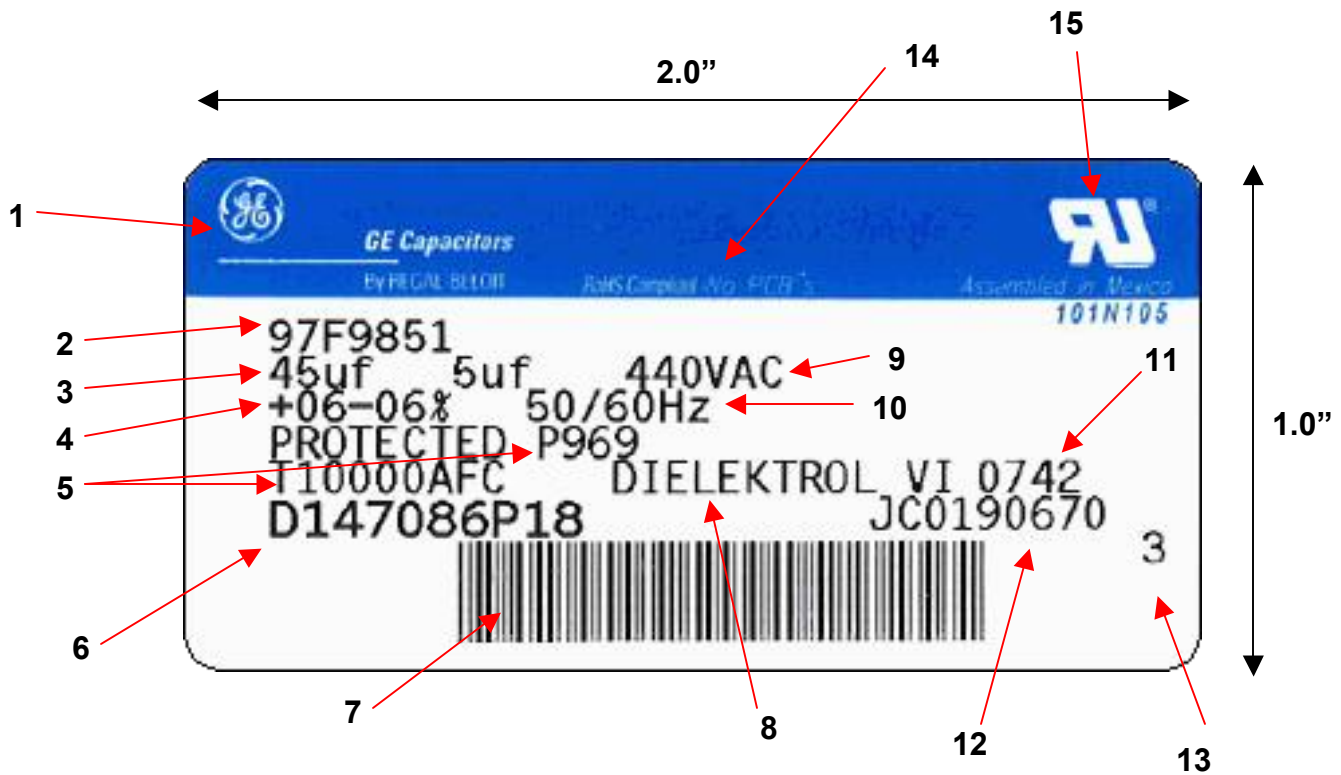

1. Product / Brand
2. GE / RBC Catalog Model Number
3. Capacitance in Micro-Farads
4. Tolerance
5. UL Designation Including Available Fault Current (AFC) Rating
6. Customer Part Number
7. Bar Code
8. GE Product Name of Dielectric Fluid
9. AC Voltage Rating
10. Frequency

11. Manufacturing Date Code

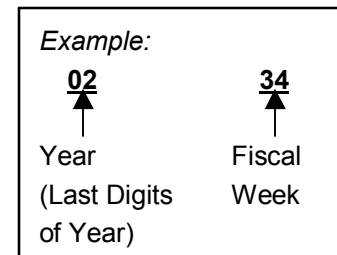

12. Manufacturing WIP Job Number
13. Label Sequence Number
14. RoHS Compliant Statement
15. UL Approved Logo

AVAILABLE REGAL-BELOIT COMPONENT CAPACITOR PUBLICATIONS		
Publication	Description	Replaces
GEC-001	AC Capacitors for Motor Run Applications	CPD-510
GEC-002	AC Capacitors for HID Lighting Applications	CPD-511
GEC-003	Capacitors for AC and DC General Purpose Applications	CPD-512
GEC-004	Power Electrolytic Capacitors	CPD-517
GEC-005	Snubber, High Current DC, and Switching Capacitors	CPD-518, 519, 520
GEC-006	Dry Capacitors	New Pub.
PLC-001	PROLINE Capacitors	New Pub.

Please contact your local Regal-Beloit Sales Representative for further information.

Call or write directly to:

GE Capacitors by Regal-Beloit

1946 West Cook Road
Fort Wayne, Indiana 46818 USA

Phone: (260) 416-5400

Fax: (260) 416-5460

Email: capacitors@regalbeloit.com



GE Capacitors

By REGAL-BELOIT



GE Capacitors by Regal-Beloit 1946 West Cook Road, Fort Wayne, Indiana 46818 USA

Phone: (260) 416-5400 **Fax:** (260) 416-5460 **Email:** capacitors@regalbeloit.com

www.gecapacitors.com

