

Customer Information Sheet

G No.: S25-XX6 SHEET 2 OF 2 IF IN DOUBT - ASK © NOT TO SCALE THIRD ANGLE PROJECTION ALL DIMENSIONS IN mm

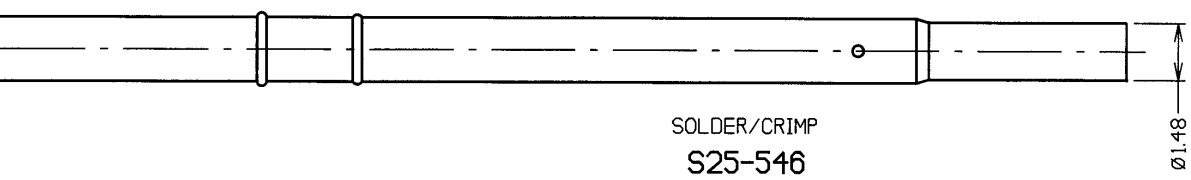
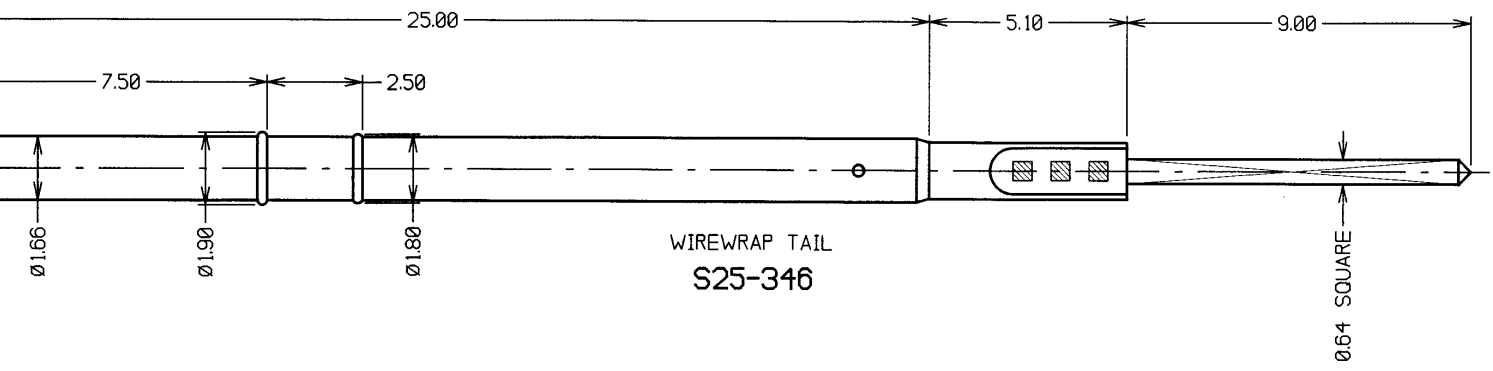

- NOTES:
1. TO BE USED WITH PROBES P25-XX26.
 2. SUITABLE FOR A MINIMUM DISTANCE BETWEEN CENTRES OF 2.54mm.
 3. SPECIFICATIONS FOR PROBE PERFORMANCE ARE GIVEN ON THE PROBE DRAWING.
 4. RECOMMENDED HOLE SIZES:
 ACRYLIC = $\varnothing 1.70\text{mm}$.
 BAKELITE = $\varnothing 1.75\text{mm}$.
 FIBRE REINFORCED PLASTIC = $\varnothing 1.75\text{mm}$.

2	07.03.01	5730
ISS.	DATE	IC/NOTE
APPROVED: <i>[Signature]</i>		
CHECKED: <i>[Signature]</i>		
DRAWN: W. J. BOURNE		
CUSTOMER REF.:		
ASSEMBLY DRG:		

ORDER CODE:
S25-XX6
 SPRING PROBE
 SLEEVE (SEE ABOVE)

			THIS DRAWING AND ANY INFORMATION OR DESCRIPTIVE MATTER SET OUT HEREON ARE CONFIDENTIAL AND COPYRIGHT PROPERTY OF THE HARWIN GROUP AND MUST NOT BE DISCLOSED, LOANED, COPIED OR USED FOR MANUFACTURING, TENDERING OR FOR ANY OTHER PURPOSE WITHOUT THEIR WRITTEN PERMISSION.	TOLERANCES X. - $\pm 1\text{mm}$ X.X - $\pm 0.25\text{mm}$ X.XX - $\pm 0.10\text{mm}$ X.XXX - $\pm 0.01\text{mm}$ ANGLES - $\pm 1^\circ$ UNLESS STATED	MATERIAL: PHOSPHOR BRONZE FINISH: GOLD S/AREA: mm ²	TITLE: 2.54mm MIN. CENTRE TWO-PIECE SPRING PROBE SLEEVE DRAWING NUMBER: S25-XX6	SHT 2 OF 2
HARWIN INC U.S.A. (2) 285 0055 (2) 285 0056	HARWIN PLC U.K. TEL: 023 9237 0451 FAX: 023 9231 4590	HARWIN PTE SINGAPORE TEL: 65 7794909 FAX: 65 7793868					