

# Customer Information Sheet

DRAWING No. S25-XX2      SHEET 2 OF 2      IF IN DOUBT - ASK      ©      NOT TO SCALE      THIRD ANGLE PROJECTION      ALL DIMENSIONS IN mm

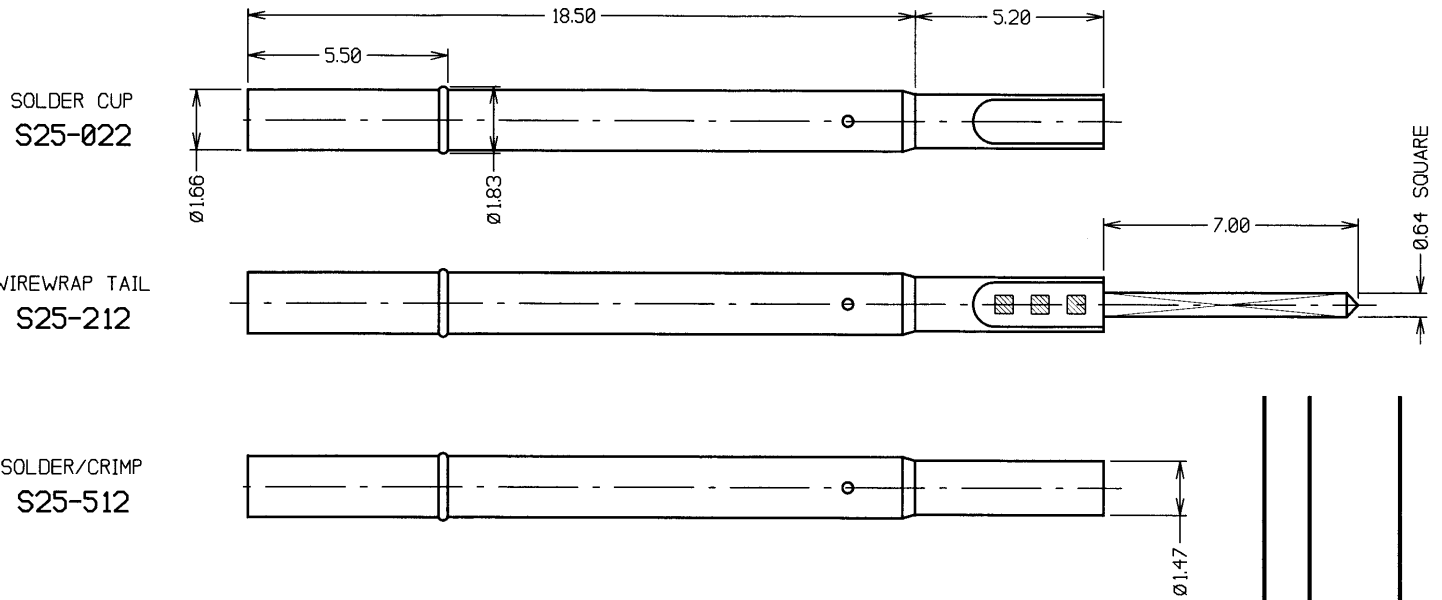

- NOTES:
1. TO BE USED WITH PROBES P25-0822 AND P25-XX23.
  2. SUITABLE FOR A MINIMUM DISTANCE BETWEEN CENTRES OF 2.54mm.
  3. SPECIFICATIONS FOR PROBE PERFORMANCE ARE GIVEN ON THE PROBE DRAWING.
  4. RECOMMENDED HOLE SIZES:  
 ACRYLIC =  $\varnothing 1.70\text{mm}$ .  
 BAKELITE =  $\varnothing 1.75\text{mm}$ .  
 FIBRE REINFORCED PLASTIC =  $\varnothing 1.75\text{mm}$ .

ORDER CODE:  
**S25-XX2**  
 SPRING PROBE  
 SLEEVE (SEE ABOVE)

2	07.03.01	5730
ISS.	DATE	C/NOTE
APPROVED: <i>[Signature]</i>		
CHECKED: <i>[Signature]</i>		
DRAWN: W. J. BOURNE		
CUSTOMER REF.:		
ASSEMBLY DRG:		



THIS DRAWING AND ANY INFORMATION OR DESCRIPTIVE MATTER SET OUT HEREON ARE CONFIDENTIAL AND COPYRIGHT PROPERTY OF THE HARWIN GROUP AND MUST NOT BE DISCLOSED, LOANED, COPIED OR USED FOR MANUFACTURING, TENDERING OR FOR ANY OTHER PURPOSE WITHOUT THEIR WRITTEN PERMISSION.

TOLERANCES  
 X. -  $\pm 1\text{mm}$   
 XX -  $\pm 0.25\text{mm}$   
 XXX -  $\pm 0.10\text{mm}$   
 XXXX -  $\pm 0.01\text{mm}$   
 ANGLES -  $\pm 1^\circ$   
 UNLESS STATED

MATERIAL:  
 PHOSPHOR BRONZE  
 FINISH: GOLD  
 S/AREA: mm<sup>2</sup>

TITLE:  
 2.54mm MIN. CENTRE TWO-PIECE  
 SPRING PROBE SLEEVE  
 DRAWING NUMBER: **S25-XX2**  
 SHT 2 OF 2

HARWIN INC U.S.A. TEL: (812) 285 0055 FAX: (812) 285 0056	HARWIN PLC UK. TEL: 023 9237 0451 FAX: 023 9231 4590	HARWIN PTE SINGAPORE TEL: 65 7794909 FAX: 65 7793868
--	---	---