

REVISIONS		REVISED DATE	APPR
SYM	DESCRIPTION		

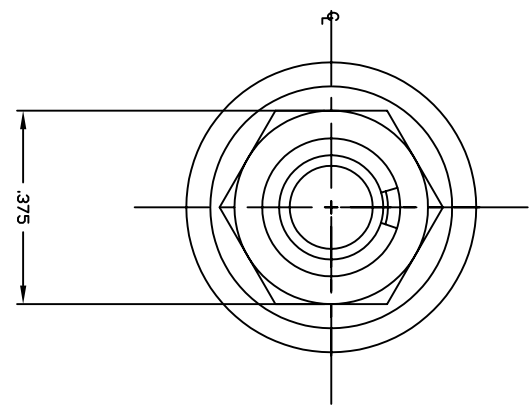
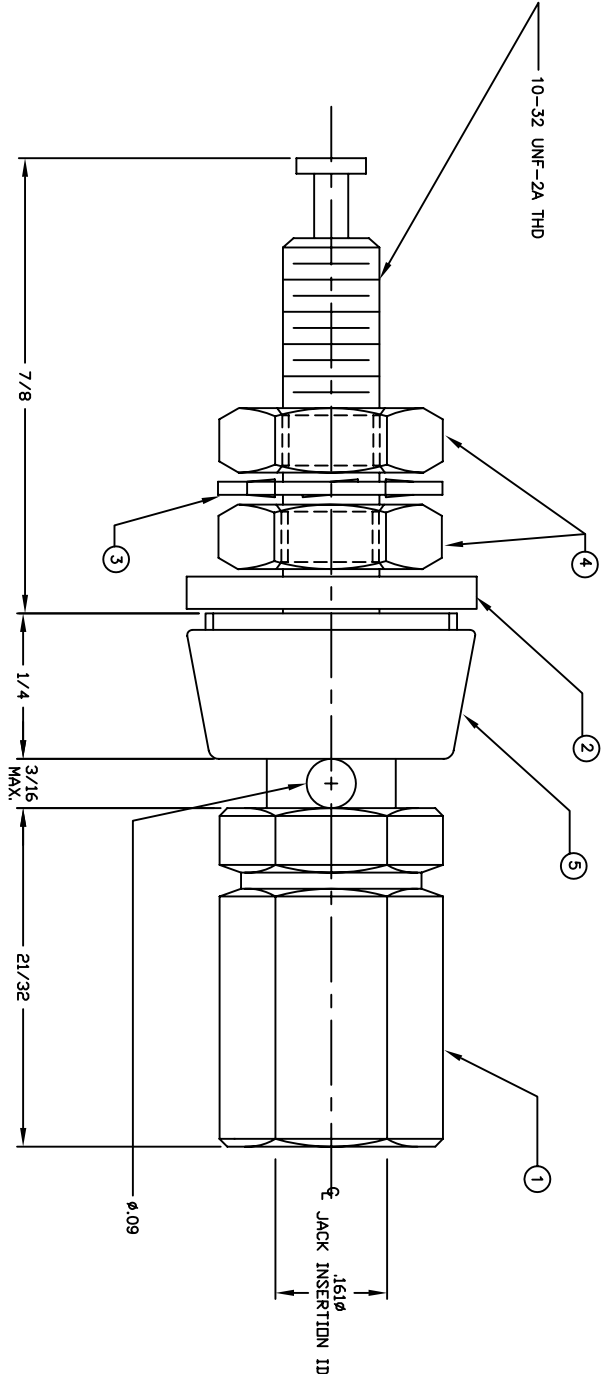
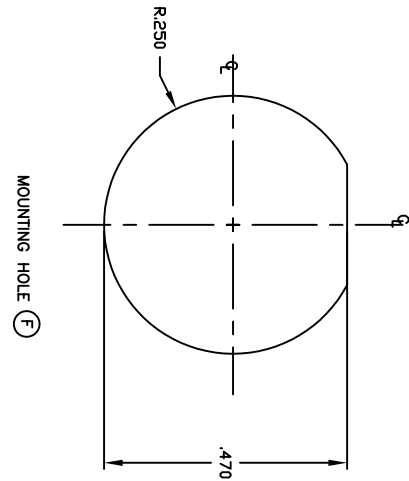

NOTE: 1/16 MIN
3/8 MAX
PANEL

BILL OF MATERIALS				
DET.	QTY.	DESCRIPTION	MATERIAL	PLATING
1	1	B/P SUB-ASSY	BRASS	SEE DWG
2	1	WASHER	BRASS	NICKEL
3	1	LOCKWASHER	STEEL	ZINC
4	2	HEX NUTS	BRASS	NICKEL
5	1	WASHER	BRASS	NICKEL

MATERIAL "SEE TABLE"		FINISH "SEE TABLE"	
DIMENSIONAL TOLERANCES			
UNLESS OTHERWISE SPECIFIED			
.XX	.XXX	.XXX	.XXX
FRACTIONS	ANGLES	SCALE	
---	---	5:1	
HEAT TREAT	---		
PLAT SCALE	1:1		
TITLE		DRAWN: T. LORD	
1835		DATE: 12/3/02	
BINDING POST		CHECKED: T. LORD	
		DATE: 12/3/02	
		APPROVED: T. LORD	
Electronic Connectors and Hardware		SIZE	DRAWING NUMBER
632 Arch Street, Meadville, Pa. 16335		C	SD-1835
		ISSUE	F

ABBATRON