

Banana Jack - Insulated Solder Terminal

SPECIFICATIONS

Contact: Formed brass per QQ-B-626D

Finish: Bright tin

Body: Nylon 6/6 per ASTM D4066

Hardware: Nickel plated nut (unassembled)

Body Thread Stripping Torque: 6.0 lb. in. (7kg. cm.)

Panel Thickness: Up to .343 (8.80)

RATINGS

Current: 15 amps

Breakdown Voltage: 7000 Vrms minimum †

Contact Resistance: 0.010 ohms maximum

Contact-To-Panel: 2.4 pF nominal

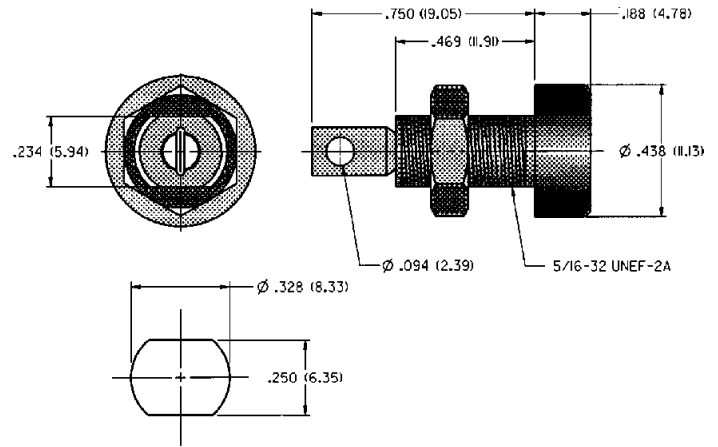
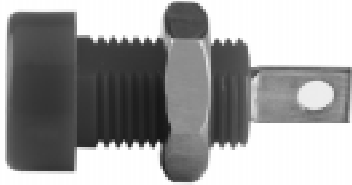

MOUNTING HOLE LAYOUT

BRIGHT TIN PLATING

108-0902-001 Red

For Standard Banana Plug: .175 (4.44) Across Flats

FEATURES:

- Keyed mounting with double flats
- Accepts up to 16 gauge wire
- Nylon UL approved for self extinguishing