

Doc # SD-19071-006
SD041

MATERIAL: Copper
 PLATING: Electro-Tin (.0003 Min.)
 INSULATION: PVC, Color Coded Blue
 STUD SIZES: ("D" ±.005)

INSULKRIMP X

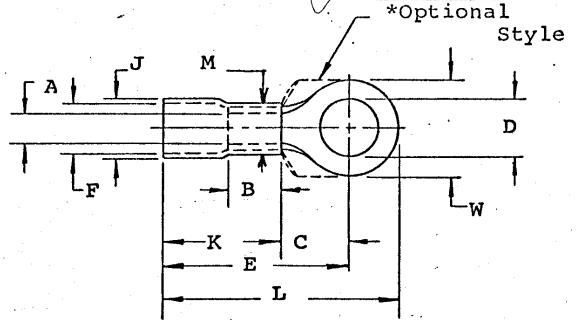

"M" - .740" Maximum

Part Number	"W"	"C" Min.	"E" Max.	"K" Max.	"L"	"A" Min.Avg.	"F" (MWID)	Stock Thickness	"J" Max.	"B" Min.	Available Stud Size
H-680-X*	.894 .870	.740		1.355		.430	.680	.075	.805	.660	14, 56, 38, 76 12
H-681-X	.833 .807	.740	2.235	1.455	2.620	.430	.680	.075	.805	.660	14, 56, 38
H-682-X	1.270 1.244	1.276		1.355		.430	.680	.075	.805	.660	38, 12, 58, 34 78

NOTE: (MWID) denotes maximum wire insulation diameter.



TITLE: CUSTOMER DRAWING
 1/0 WIRE RANGE (H)
 RING TONGUE TERMINAL

DIMENSIONAL TOLERANCE UNLESS OTHERWISE SPECIFIED		
FRAC.	DEC.	ANG.
±	±	±

REVISION	SCALE: _____	DATE
	DRWN. BY: JTK	1-21-70
	CHKD. BY:	
	APPRD. BY:	
	DRAWING NO.:	