

## ROTA-CRIMP Hand Tool

Generally used in Battery Lead applications

*Image representative of type only*

### Features:

- Very large wire range covered
- Simply rotate the appropriate crimp nest into position
- Available with and without full cycle ratchet mechanism



Part Number	Description	mm <sup>2</sup> (AWG) or other
600850	Tool without Ratchet for Battery Terminals & Lugs	10.0 - 120.0 (8-4/0)
600850-1	Tool with ratchet for Battery Terminals & Lugs (pictured)	10.0 - 120.0 (8-4/0)
601129-2	Tool with Ratchet for PLASTI-GRIP & Pre-insulated AMPOWER Terminals; TERMINYL Terminals & Splices	Single Crimp 10.0 - 35.0 (8-2) Dual Crimp 1/0

## Bantam ROTA-CRIMP Hand Tool

Generally used in Battery Lead applications

*Image representative of type only*

### Features:

- Large wire range covered
- Simply rotate the appropriate crimp nest into position
- Ratchet mechanism ensures complete crimp cycle
- Easy access ratchet release



Part Number	Description	mm <sup>2</sup> (AWG) or other
601075	Tool without Ratchet for Battery Terminals & Lugs	10.0 - 50.0 (8-1/0)
601075-1	Tool with Ratchet for Battery Terminals & Lugs (pictured)	10.0 - 50.0 (8-1/0)

## Hydraulic Hand Tool - SOLISTRAND

Generally used in Military & Aerospace applications

*Image representative of type only*

### Features:

- Integral Dies, simply rotate the appropriate die into position
- Pump action die closure



Part Number	Description	mm <sup>2</sup> (AWG) or other
59975-1	SOLISTRAND Terminals & Splices	10.0 - 35.0 (8-2)

## Hydraulic Head - SOLISTRAND

A version of 59975-1 for use with powered options

### Features:

Integral Dies, simply rotate the appropriate die into position

Use with:

Optional Hose Assemblies; 1583662-1, 1583662-2 or 1583662-3

Respectively; 1.83 M (6'), 3 M (10'), 6.1 M (20')

Hand Pump 1583661-1

Foot Pump 1583659-1

Electric-Hydraulic Pumps; 439798-2, 523199-1

*Image representative of type only*



Part Number	Description	mm <sup>2</sup> (AWG) or other
1673672-1	Complete Head for SOLISTRAND Terminals & Splices	10.0 - 35.0 (8-2)

## Cable Cutter - Battery-Hydraulic Tool 100 KN

Take the effort out of cable cutting!

### Features:

use with

1-579002-9 Battery-Hydraulic Tool 100 KN

*Image representative of type only*



Part Number	Description	mm <sup>2</sup> (AWG) or other
4-1579002-5	Cutter Head only	Al & Cu up to Ø46mm (300 mm <sup>2</sup> approx)

## 'U' Die Assy

A range of Die-sets for Heavy Duty crimping

*Image representative of type only*

### Features:

Die outline dimensions conform to 'U' Die Industry Standard

Use in:

1490748-1 'U' Die 12 Ton Hydraulic Hand Tool

1490749-1 'U' Die 14 Ton Hydraulic Hand Tool

or

1213875-2 Battery-Hydraulic Tool Kit - 12 Ton 'U' Die

or

1490745-1 'U' Die 12 Ton Hydraulic Head

1490747-1 'U' Die 12 Ton Hydraulic Head (Titanium)

1490746-1 'U' Die 12 Ton Hydraulic Head - 1.5

(Excluding Die 1583097-1)

or

any 12 ton (min) compatible proprietary equipment

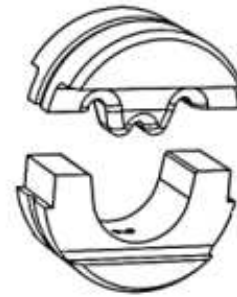

Part Number	Description	mm <sup>2</sup> (AWG) or other
1583092-1	AMPOWER Terminals & Splices - Complete Die-set	16.0 (6)
1583093-1	AMPOWER Terminals & Splices - Complete Die-set	25.0 (4)
1583094-1	AMPOWER Terminals & Splices - Complete Die-set	35.0 (2)
1583095-1	AMPOWER Terminals & Splices - Complete Die-set	50.0 (1/0)
1583096-1	AMPOWER Terminals & Splices - Complete Die-set	70.0 (2/0)
1583097-1	AMPOWER Terminals & Splices - Complete Die-set	95.0 (3/0)
1490597-1	TERMINYL Terminals & Splices - Complete Die-set (PLASTI-GRIP where no insulation crimp is required)	10.0 (8)
1490598-1	TERMINYL Terminals & Splices - Complete Die-set (PLASTI-GRIP where no insulation crimp is required)	16.0 (6)
1490599-1	TERMINYL Terminals & Splices - Complete Die-set (PLASTI-GRIP where no insulation crimp is required)	25.0 (4)

*where listed, only popular tools show - please use our online search for the latest information:*

<http://www.tooling.tycoelectronics.com/europe/Handtools.asp>

## 'U' Die Assy (14 ton)

A range of Die-sets for Heavy Duty crimping

### Features:

Die outline dimensions conform to 'U' Die Industry Standard

Use in:

1490749-1 'U' Die 14 Ton Hydraulic Hand Tool

or

1901821-1 'U' Die 12 Ton Hydraulic Head - 1.5  
(Excluding Dies; 1490576-1 & 1583098-1)

or

any 14 ton (min) compatible proprietary equipment

*Image representative of type only*



Part Number	Description	mm <sup>2</sup> (AWG) or other
1490534-1	AMPLI-BOND and PLASTI-GRIP Terminals & Splices - Complete Die-set	10.0 (8)
1490535-1	AMPLI-BOND and PLASTI-GRIP Terminals & Splices - Complete Die-set	16.0 (6)
1490536-1	AMPLI-BOND and PLASTI-GRIP Terminals & Splices - Complete Die-set	25.0 (4)
1490410-1	AMPLI-BOND and PLASTI-GRIP Terminals & Splices - Complete Die-set	35.0 (2)
1583098-1	AMPPOWER Terminals & Splices - Complete Die-set	120.0 (4/0)
1490556-1	COPALUM Sealed Terminals and Splices	Cu 10.0 (8) Al 16.0 (6)
1490557-1	COPALUM Sealed Terminals and Splices	Cu 16.0 (6) Al 25.0 (4)
1490555-1	COPALUM Sealed Terminals and Splices	Cu 8.0 (10) Al 10.0 (8)
1490573-1	COPALUM Terminals and Splices	Cu 10.0 (8) Al 16.0 (6)
1490715-1	COPALUM Terminals and Splices	Cu 10.0 (8) Al 16.0 (6)
1490574-1	COPALUM Terminals and Splices	Cu 16.0 (6) Al 25.0 (4)
1490716-1	COPALUM Terminals and Splices	Cu 16.0 (6) Al 25.0 (4)
1490575-1	COPALUM Terminals and Splices	Cu 25.0 (4) Al 35.0 (2)
1490717-1	COPALUM Terminals and Splices	Cu 25.0 (4) Al 35.0 (2)
1490576-1	COPALUM Terminals and Splices	Cu 35.0 (2) Al 50.0 (1/0)
1490718-1	COPALUM Terminals and Splices	Cu 35.0 (2) Al 50.0 (1/0)
1490572-1	COPALUM Terminals and Splices	Cu 8.0 (10) Al 10.0 (8)
1490714-1	COPALUM Terminals and Splices	Cu 8.0 (10) Al 10.0 (8)
1490406-1	TERMINYL Terminals & Splices - Complete Die-set (PLASTI-GRIP where no insulation crimp is required)	35.0 (2)
1490700-1	TERMINYL Terminals & Splices - Complete Die-set (PLASTI-GRIP where no insulation crimp is required)	50.0 (1/0)

*where listed, only popular tools show - please use our online search for the latest information:*

<http://www.tooling.tycoelectronics.com/europe/Handtools.asp>

## 'U' Die Nest

A range of Die Nests for heavy duty crimping

*Image representative of type only*

### Features:

Nest outline dimensions conform to 'U' Die Industry Standard

Use in:

1490748-1 'U' Die 12 Ton Hydraulic Hand Tool

1490749-1 'U' Die 14 Ton Hydraulic Hand Tool

or

1213875-2 Battery-Hydraulic Tool Kit - 12 Ton 'U' Die

or

1901820-1 'U' Die 12 Ton Hydraulic Head

1490747-1 'U' Die 12 Ton Hydraulic Head (Titanium)

1901821-1 'U' Die 12 Ton Hydraulic Head - 1.5

or

any 12 ton (min) compatible proprietary equipment



Part Number	Description	mm <sup>2</sup> (AWG) or other
2-1490413-1	SOLISTRAND 90° Bend Ring Tongue Terminals - use with Indenter 1490414-3	100.0 - 125.0 [4/0]
1-1490413-5	SOLISTRAND 90° Bend Ring Tongue Terminals - use with Indenter 1490414-2	13.0 - 15.0 [6]
1-1490413-6	SOLISTRAND 90° Bend Ring Tongue Terminals - use with Indenter 1490414-2	21.0 [4]
1-1490413-7	SOLISTRAND 90° Bend Ring Tongue Terminals - use with Indenter 1490414-2	34.0 - 35.0 [2]
1-1490413-8	SOLISTRAND 90° Bend Ring Tongue Terminals - use with Indenter 1490414-2	59.0 - 60.0 [1/0]
1-1490413-9	SOLISTRAND 90° Bend Ring Tongue Terminals - use with Indenter 1490414-3	67.0 - 70.0 [2/0]
1-1490413-4	SOLISTRAND 90° Bend Ring Tongue Terminals - use with Indenter 1490414-1	7.0 - 8.0 [8]
2-1490413-0	SOLISTRAND 90° Bend Ring Tongue Terminals - use with Indenter 1490414-3	80.0 - 95.0 [3/0]
1752680-8	SOLISTRAND Flag Terminals - use with Indenter 1752681-2	10.0 (8)
1752680-1	SOLISTRAND Flag Terminals - use with Indenter 1752681-1	120.0 (4/0)
1752680-7	SOLISTRAND Flag Terminals - use with Indenter 1752681-3	16.0 (6)
1752680-6	SOLISTRAND Flag Terminals - use with Indenter 1752681-3	25.0 (4)
1752680-5	SOLISTRAND Flag Terminals - use with Indenter 1752681-3	35.0 (2)
1752680-4	SOLISTRAND Flag Terminals - use with Indenter 1752681-1	50.0 (1/0)
1752680-3	SOLISTRAND Flag Terminals - use with Indenter 1752681-1	70.0 (2/0)
1752680-2	SOLISTRAND Flag Terminals - use with Indenter 1752681-1	95.0 (3/0)
1-1490413-0	SOLISTRAND HD Terminals & Splices - use with Indenter 1490414-2	13.0 - 15.0 [6] HD
1-1490413-1	SOLISTRAND HD Terminals & Splices - use with Indenter 1490414-2	21.0 [4] HD
1-1490413-2	SOLISTRAND HD Terminals & Splices - use with Indenter 1490414-3	34.0 - 35.0 [2] HD
1-1490413-3	SOLISTRAND HD Terminals & Splices - use with Indenter 1490414-3	59.0 - 60.0 [1/0] HD
1490413-9	SOLISTRAND HD Terminals & Splices - use with Indenter 1490414-2	7.0 - 8.0 [8] HD
1490413-8	SOLISTRAND; STRATO-THERM SOLISTRAND Terminals & Splices - use with Indenter 1490414-3	100.0 - 125.0 [4/0]
1490413-2	SOLISTRAND; STRATO-THERM SOLISTRAND Terminals & Splices - use with Indenter 1490414-2	13 - 15 [6]
1490413-3	SOLISTRAND; STRATO-THERM SOLISTRAND Terminals & Splices - use with Indenter 1490414-2	21.0 (4)
1490413-4	SOLISTRAND; STRATO-THERM SOLISTRAND Terminals & Splices - use with Indenter 1490414-2	34.0 - 35.0 [2]
1490413-5	SOLISTRAND; STRATO-THERM SOLISTRAND Terminals & Splices - use with Indenter 1490414-3	59.0 - 60.0 [1/0]
1490413-6	SOLISTRAND; STRATO-THERM SOLISTRAND Terminals & Splices - use with Indenter 1490414-3	67.0 - 70.0 [2/0]
1490413-1	SOLISTRAND; STRATO-THERM SOLISTRAND Terminals & Splices - use with Indenter 1490414-1	7.0 - 8.0 [8]
1490413-7	SOLISTRAND; STRATO-THERM SOLISTRAND Terminals & Splices - use with Indenter 1490414-3	80.0 - 95.0 [3/0]

where listed, only popular tools show - please use our online search for the latest information:

<http://www.tooling.tycoelectronics.com/europe/Handtools.asp>

## 'U' Die Indenter

A range of Indenters for Heavy Duty crimping

*Image representative of type only*

### Features:

Indenter outline dimensions conform to 'U' Die Industry Standard

Use in:

1490748-1 'U' Die 12 Ton Hydraulic Hand Tool

1490749-1 'U' Die 14 Ton Hydraulic Hand Tool

or

1213875-2 Battery-Hydraulic Tool Kit - 12 Ton 'U' Die

or

1901820-1 'U' Die 12 Ton Hydraulic Head

1490747-1 'U' Die 12 Ton Hydraulic Head (Titanium)

1901821-1 'U' Die 12 Ton Hydraulic Head - 1.5

or

any 12 ton (min) compatible proprietary equipment

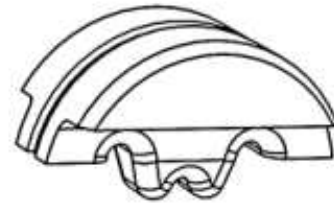

Part Number	Description	mm <sup>2</sup> (AWG) or other
1490414-2	SOLISTRAND & HD; STRATO-THERM SOLISTRAND; SOLISTRAND 90° Bend Terminals & Splices	13.0 - 35.0 [6-2] 7.0 - 21.0 [8-4] HD
1490414-3	SOLISTRAND & HD; STRATO-THERM SOLISTRAND; SOLISTRAND 90° Bend Terminals & Splices	59.0 - 125.0 [1/0-4/0] 34.0 - 60 [2-1/0]HD
1490414-1	SOLISTRAND & HD; STRATO-THERM SOLISTRAND; SOLISTRAND 90° Bend Terminals & Splices	7.0 - 8.0 [8] 7.0 - 8.0 [8] HD
1752681-2	SOLISTRAND Flag Terminals - use with nest 1752680-8	10.0 (8)
1752681-3	SOLISTRAND Flag Terminals - use with nests; 1752680-5, 1752680-6, 1752680-7	16.0 - 35.0 (6-2)
1752681-1	SOLISTRAND Flag Terminals - use with nests; 1752680-1, 1752680-2, 1752680-3, 1752680-4	50.0 - 120.0 (1/0-4/0)
1901657-3	SOLISTRAND HD Seamless Ring Tongue Terminals & Butt Splices use with Nests; 1-1490413-8, 1- -9, 2- -0, 2- -1	[1/0-4/0]
1901657-2	SOLISTRAND HD Seamless Ring Tongue Terminals & Butt Splices use with Nests; 1-1490413-5, 1- -6, 1- -7	[6-1]
1901657-1	SOLISTRAND HD Seamless Ring Tongue Terminals & Butt Splices use with Nest 1-1490413-4	[8]

## 'U' Die 12 Ton Hydraulic Hand Tool

Suitable for ALL 'U' Dies - with the exception of 'U' Die Assy (14 ton)

*Image representative of type only*

### Features:

36.5mm (1.2") stroke for faster crimping

Pump action die closure

Circa 20,000 cycles



Part Number	Description	mm <sup>2</sup> (AWG) or other
1490748-1	Tool without Die-set (U Die alternative to 59974-1)	12 Ton U Dies only

## 'U' Die 14 Ton Hydraulic Hand Tool

Suitable for ALL 'U' Dies

*Image representative of type only*

### Features:

- 38mm (1.5") stroke
- Pump action die closure
- Circa 20,000 cycles



Part Number	Description	mm <sup>2</sup> (AWG) or other
1490749-1	Tool without Die-set (U Die alternative to 59973-1)	Any U Die

## 'U' Die 12 Ton Hydraulic Head

Suitable for ALL 'U' Dies - with the exception of 'U' Die Assy (14 ton)

*Image representative of type only*

### Features:

- 36.5mm (1.2") stroke for fast cycle
- Rated for use with 700 bar (10,000 psi) pump units
- Circa 20,000 cycles

Use with:

- Optional Hose Assemblies; 1583662-1, 1583662-2 or 1583662-3 Respectively; 1.83 M (6'), 3 M (10'), 6.1 M (20')
- Hand Pump 1583661-1
- Foot Pump 1583659-1
- Electric-Hydraulic Pumps; 1804700-2, 523199-1



Part Number	Description	mm <sup>2</sup> (AWG) or other
1490745-1	Head without dies 25.4mm (1") stroke (U Die alternative to 69051)	
1490747-1	Lightweight Titanium Head without dies (U Die alternative to 69051)	12 Ton U Dies only

## Battery-Hydraulic Tool Kit - 12 Ton 'U' Die

Suitable for ALL 'U' Dies - with the exception of 'U' Die Assy (14 ton)

*Image representative of type only*

### Features:

- Rotating Head 320°
- Excellent power to weight ratio
- Circa 10,000 Cycles

Kit Includes:

- Crimp Tool
- Battery Charger 220v (PN 1213873-2)
- Rechargeable Battery (PN 1213872-1)
- Carry Case with strap



Part Number	Description	mm <sup>2</sup> (AWG) or other
1213875-2	Complete Kit with EU Power Plug	12 Ton U Dies only

## 'U' Die 14 Ton Hydraulic Head

Suitable for ALL 'U' Dies

### Features:

38mm (1.5") Stroke  
 Rated for use with 700 bar (10,000 psi) pump units  
 Rated for 20,000 cycles

### Use with:

Optional Hose Assemblies; 1583662-1, 1583662-2 or 1583662-3  
 Respectively; 1.83 M (6'), 3 M (10'), 6.1 M (20')  
 Hand Pump 1583661-1  
 Foot Pump 1583659-1  
 Electric-Hydraulic Pumps; 1804700-2, 523199-1

*Image representative of type only*



Part Number	Description	mm <sup>2</sup> (AWG) or other
1490746-1	Head without dies 38mm (1.5") stroke (U Die alternative to 69051)	Any U Die

## 'U' Die 14 Ton Hydraulic Head - Latched

Suitable for ALL 'U' Dies

### Features:

Latched Head for added strength  
 38mm (1.5") Stroke  
 Rated for use with 700 bar (10,000 psi) pump units

### Use with:

Optional Hose Assemblies; 1583662-1, 1583662-2 or 1583662-3  
 Respectively; 1.83 M (6'), 3 M (10'), 6.1 M (20')  
 Hand Pump 1583661-1  
 Foot Pump 1583659-1  
 Electric-Hydraulic Pumps; 1804700-2, 523199-1

*Image representative of type only*



Part Number	Description	mm <sup>2</sup> (AWG) or other
1976230-1	Head (Latched) without Dies	Any U Die



## Dies for Battery Tool Kit - 4 Ton Latch Head

*Image representative of type only*

### Features:

Use in:

1901343-2 Battery Tool Kit with retract switch (EU power plug)

1901343-4 Battery Tool Kit without retract switch (EU power plug)

Part Number	Description	mm <sup>2</sup> (AWG) or other
1976977-1	Die-set for PIDG STRATO-THERM Terminals & Splices with PTFE or PEEK thin-wall Insulation	4.0 (12)
1976976-1	Die-set for PIDG STRATO-THERM Terminals & Splices with PTFE or PEEK thin-wall Insulation	6 (10.0)
1901001-1	Die-Nest for SOLISTRAND Terminals & Splices - use with Indenter 1901002-2	10.0 (8)
1901002-2	Die-Indenter for SOLISTRAND Terminals & Splices - use with Nest 1901001-1	10.0 (8)
1901002-1	Die-Indenter for SOLISTRAND Terminals & Splices - use with Nest's; 1901000-1, 1901000-2, 1901000-3	16.0 - 35 (6-2)
1901000-1	Die-Nest for SOLISTRAND Terminals & Splices - use with Indenter 1901002-1	16.0 (6)
1901000-2	Die-Nest for SOLISTRAND Terminals & Splices - use with Indenter 1901002-1	25.0 (4)
1901000-3	Die-Nest for SOLISTRAND Terminals & Splices - use with Indenter 1901002-1	35.0 (2)
1901006-1	Die-set for TERMINYL Terminals & Splices; (PLASTI-GRIP where no insulation crimp is required)	10.0 (8) Red
1901007-1	Die-set for TERMINYL Terminals & Splices; (PLASTI-GRIP where no insulation crimp is required)	16.0 (6) Blue

## Battery Tool Kit - 4 Ton Latch Head

Ideal for low to medium production volumes

*Image representative of type only*

### Features:

Over 80 crimps per charge

Compact - only 356mm (14") long and weighs 1.6 kg (3.5lbs)

The Tool Kit is supplied in a durable plastic Carry Case and includes:

Battery Tool with Latched Head

Battery Charger 220v

Two Batteries

Spares

Battery Charger 220v (PN 1725840-2) EU power plug

Rechargeable Battery (PN 1725839-1)

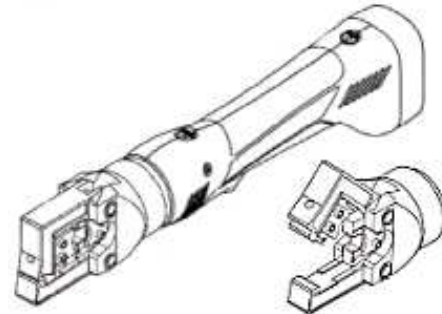

Part Number	Description	mm <sup>2</sup> (AWG) or other
1901343-2	Battery Tool Kit - 4 Ton Latch Head with retract switch (EU power plug)	
1901343-4	Battery Tool Kit - 4 Ton Latch Head without retract switch (EU power plug)	

**Die-set - Hydraulic Head Open (Shank Die)***Image representative of type only***Features:**

Can be used with

Head 1752868-1 - 700 bar (10,000 psi)

or

Head 69099 - 580 bar (8,200 psi)



Part Number	Description	mm <sup>2</sup> (AWG) or other
68044	COPALUM Terminals and Splices	Cu 10.0 (8) Al 16.0 (6)
68085	COPALUM Terminals and Splices	Cu 10.0 (8) Al 16.0 (6)
68045	COPALUM Terminals and Splices	Cu 16.0 (6) Al 25.0 (4)
68086	COPALUM Terminals and Splices	Cu 16.0 (6) Al 25.0 (4)
68046	COPALUM Terminals and Splices	Cu 25.0 (4) Al 35.0 (2)
68130	COPALUM Terminals and Splices	Cu 25.0 (4) Al 35.0 (2)
68047	COPALUM Terminals and Splices	Cu 35.0 (2) Al 50.0 (1/0)
68131	COPALUM Terminals and Splices	Cu 35.0 (2) Al 50.0 (1/0)
68048	COPALUM Terminals and Splices	Cu 50.0 (1/0) Al 70.0 (2/0)
68132	COPALUM Terminals and Splices	Cu 50.0 (1/0) Al 70.0 (2/0)
68049	COPALUM Terminals and Splices	Cu 70.0 (2/0) Al 95.0 (3/0)
68133	COPALUM Terminals and Splices	Cu 70.0 (2/0) Al 95.0 (3/0)
68043	COPALUM Terminals and Splices	Cu 8.0 (10) Al 10.0 (8)
68084	COPALUM Terminals and Splices	Cu 8.0 (10) Al 10.0 (8)
318106-1	COPALUM Terminals and Splices	Cu 95.0 (3/0) Al 120.0 (4/0)
69216	SOLISTRAND Terminals & Splices	10.0 (8)
45445	SOLISTRAND Terminals & Splices	120.0 (4/0)
69217	SOLISTRAND Terminals & Splices	16.0 (6)
69218	SOLISTRAND Terminals & Splices	25.0 (4)
45433	SOLISTRAND Terminals & Splices	35.0 (2)
45436	SOLISTRAND Terminals & Splices	50.0 (1/0)
45439	SOLISTRAND Terminals & Splices	70.0 (2/0)
45442	SOLISTRAND Terminals & Splices	95.0 (3/0)
69211-1	STRATO-THERM Post Insulated Terminals & Splices	10.0 (8)
69212-1	STRATO-THERM Post Insulated Terminals & Splices	16.0 (6)
69213-1	STRATO-THERM Post Insulated Terminals & Splices	25.0 (4)
69214-1	STRATO-THERM Post Insulated Terminals & Splices	35.0 (2)
69215-1	STRATO-THERM Post Insulated Terminals & Splices	50.0 (1/0)
69254-1	STRATO-THERM Post Insulated Terminals & Splices	70.0 (2/0)

where listed, only popular tools show - please use our online search for the latest information:

<http://www.tooling.tycoelectronics.com/europe/Handtools.asp>

## Hydraulic Head Open (Shank Die)

**Features:**

Rated for use with 700 bar (10,000 psi) pump units

Use with:

Optional Hose Assemblies; 1583662-1, 1583662-2 or 1583662-3  
Respectively; 1.83 M (6'), 3 M (10'), 6.1 M (20')

Hand Pump 1583661-1

Foot Pump 523199-2

Electric-Hydraulic Pumps; 1804700-2, 523199-1

*Image representative of type only*



Part Number	Description	mm <sup>2</sup> (AWG) or other
1752868-1	Hydraulic Head without Die-set (700 bar equivalent of 69099)	

## Hydraulic Head Open - Dyna-Crimp

**Features:**

Rated for use with 580 bar (8,200 psi) pump units

Use with:

Optional Hose Assemblies; 59909-7, 1-59909-5 or 2-59909-1  
Respectively; 2.12 M (7'), 4.58 M (15'), 6.4 M (21')

Hand Pump 314979-1

Foot Pump 523199-3

Electric-Hydraulic Pump; 69120-2

*Image representative of type only*



Part Number	Description	mm <sup>2</sup> (AWG) or other
69099	Hydraulic Head without Die-Set	

## Die-set - Hydraulic Head Closed (Shank Die)

### Features:

Use in Heads:

1752787-1 & 1752877-1 - 700 bar (10,000 psi)

or

Dynacrimp Heads:

58422-1 & 69066 - 580 bar (8,200 psi)

Dies listed with \* can only be used in Heads:

1752787-1 & 58422-1

see also relevant Die Instruction Sheet for more details

*Image representative of type only*



Part Number	Description	mm <sup>2</sup> (AWG) or other
48860-1	AMPLI-BOND and PLASTI-GRIP Terminals and Splices	25.0 (4)
48861-1	AMPLI-BOND and PLASTI-GRIP Terminals & Splices	35.0 (2)
314948-1	* COPALUM Sealed Terminals and Splices	120.0 (4/0)
68007	COPALUM Sealed Terminals and Splices	Cu 10.0 (8) Al 16.0 (6)
68008	COPALUM Sealed Terminals and Splices	Cu 16.0 (6) Al 25.0 (4)
68009	COPALUM Sealed Terminals and Splices	Cu 25.0 (4) Al 35.0 (2)
68010-1	COPALUM Sealed Terminals and Splices	Cu 35.0 (2) Al 50.0 (1/0)
68011-1	* COPALUM Sealed Terminals and Splices	Cu 50.0 (1/0) Al 70.0 (2/0)
314964-1	COPALUM Sealed Terminals and Splices	Cu 50.0 (1/0) Al 70.0 (2/0)
59877-1	* COPALUM Sealed Terminals and Splices	Cu 70.0 (2/0) Al 95.0 (3/0)
68006	COPALUM Sealed Terminals and Splices	Cu 8.0 (10) Al 10.0 (8)
47824	TERMINYL Terminals & Splices (PLASTI-GRIP where no insulation crimp is required)	50.0 (1/0)
47825	TERMINYL Terminals & Splices (PLASTI-GRIP where no insulation crimp is required)	70.0 (2/0)

## Hydraulic Head Closed (Shank Die)

### Features:

Rated for use with 700 bar (10,000 psi) pump units

Use with:

Optional Hose Assemblies; 1583662-1, 1583662-2 or 1583662-3  
Respectively; 1.83 M (6'), 3 M (10'), 6.1 M (20')

Hand Pump 1583661-1

Foot Pump 523199-2

Electric-Hydraulic Pumps; 1804700-2, 523199-1

*Image representative of type only*

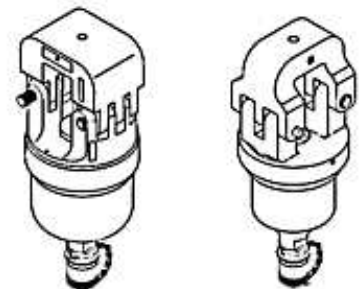

1752787-1

1752877-1

Part Number	Description	mm <sup>2</sup> (AWG) or other
1752787-1	Hydraulic Head without Die-set (700 bar equivalent of 58422-1)	
1752877-1	Hydraulic Head without Die-set (700 bar equivalent of 69066) - lighter than 1752787-1	

where listed, only popular tools show - please use our online search for the latest information:

<http://www.tooling.tycoelectronics.com/europe/Handtools.asp>

## Hydraulic Head Closed - Dyna-Crimp

### Features:

Rated for use with 580 bar (8,200 psi) pump units

Use with:

Optional Hose Assemblies; 59909-7, 1-59909-5 or 2-59909-1  
Respectively; 2.12 M (7'), 4.58 M (15') 6.4 M (21')

Hand Pump 314979-1

Foot Pump 523199-3

Electric-Hydraulic Pump; 69120-2

*Image representative of type only*

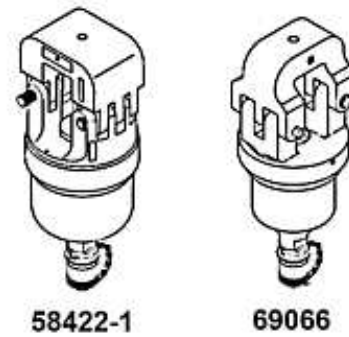

Part Number	Description	mm <sup>2</sup> (AWG) or other
58422-1	Head without dies	
69066	Head without dies - lighter than 58422-1	

## Die-set - Hydraulic Head Open (Shank Die H'Duty)

### Features:

Can be used with

Head 1752786-1 - 700 bar (10,000 psi)

or

Head 69082 - 580 bar (8,200 psi)

*Image representative of type only*



Part Number	Description	mm <sup>2</sup> (AWG) or other
46760-2	AMPOWER Terminals & Splices	1,000 MCM HD
69653	AMPOWER Terminals and Splices	350 MCM
46754-2	AMPOWER Terminals & Splices	400 MCM
46755-2	AMPOWER Terminals & Splices	500 MCM
46756-2	AMPOWER Terminals & Splices	600 MCM
59870-1	AMPOWER Terminals and Splices	600 MCM HD
46757-2	AMPOWER Terminals & Splices	700 MCM
46758-2	AMPOWER Terminals & Splices	800 MCM
46759-2	AMPOWER Terminals & Splices	900 MCM
68034	COPALUM Terminals and Splices	Cu 120.0 (4/0) Al 250 MCM
68035	COPALUM Terminals and Splices	Cu 250 MCM Al 300 MCM
68036	COPALUM Terminals and Splices	Cu 300 MCM Al 400 MCM
68037	COPALUM Terminals and Splices	Cu 400 MCM Al 500 MCM
68050	COPALUM Terminals and Splices	Cu 95.0 (3/0) Al 120.0 (4/0)
68129	COPALUM Terminals and Splices	Cu 95.0 (3/0) Al 120.0 (4/0)
69911	SOLISTRAND Terminals & Splices	250 - 300 MCM
69912	SOLISTRAND Terminals & Splices	300 - 350 MCM
69913	SOLISTRAND Terminals & Splices	400 MCM
69914	SOLISTRAND Terminals & Splices	500 - 600 MCM

where listed, only popular tools show - please use our online search for the latest information:

<http://www.tooling.tycoelectronics.com/europe/Handtools.asp>

## Hydraulic Head Open (Shank Die Heavy Duty)

**Features:**

Rated for use with 700 bar (10,000 psi) pump units

Use with:

Optional Hose Assemblies; 1583662-1, 1583662-2 or 1583662-3  
Respectively; 1.83 M (6'), 3 M (10'), 6.1 M (20')

Hand Pump 1583661-1

Foot Pump 523199-2

Electric-Hydraulic Pumps; 1804700-2, 523199-1

*Image representative of type only*



Part Number	Description	mm <sup>2</sup> (AWG) or other
1752786-1	Hydraulic Head without Die-set (700 bar equivalent of 69082)	

## Hydraulic Head Open (Heavy Duty) - Dyna-Crimp

**Features:**

Rated for use with 580 bar (8,200 psi) pump units

Use with:

Optional Hose Assemblies; 59909-7, 1-59909-5 or 2-59909-1  
Respectively; 2.12 M (7'), 4.58 M (15') 6.4 M (21')

Hand Pump 314979-1

Foot Pump 523199-3

Electric-Hydraulic Pump; 69120-2

*Image representative of type only*



Part Number	Description	mm <sup>2</sup> (AWG) or other
69082	Head without dies	

## Die-set - Hydraulic Head Closed (Shank Die H'Duty)

**Features:**

Can be used with

Head 1752788-1 - 700 bar (10,000 psi)

or

Head 58445-1 - 580 bar (8,200 psi)

*Image representative of type only*



Part Number	Description	mm <sup>2</sup> (AWG) or other
48816	SOLISTRAND Terminals & Splices	250 - 300 MCM
48817	SOLISTRAND Terminals & Splices	300 - 350 MCM
48818	SOLISTRAND Terminals & Splices	400 MCM
48819	SOLISTRAND Terminals & Splices	500 - 600 MCM

## Hydraulic Head Closed (Shank Die Heavy Duty)

**Features:**

Rated for use with 700 bar (10,000 psi) pump units

Use with:

Optional Hose Assemblies; 1583662-1, 1583662-2 or 1583662-3  
Respectively; 1.83 M (6'), 3 M (10'), 6.1 M (20')

Hand Pump 1583661-1

Foot Pump 523199-2

Electric-Hydraulic Pumps; 1804700-2, 523199-1

*Image representative of type only*



Part Number	Description	mm <sup>2</sup> (AWG) or other
1752788-1	Heavy Duty Hydraulic Head without Die-set (700 bar equivalent of 58445-1)	

## Hydraulic Head Closed (Heavy duty) - Dyna-Crimp

**Features:**

Rated for use with 580 bar (8,200 psi) pump units

Use with:

Optional Hose Assemblies; 59909-7, 1-59909-5 or 2-59909-1  
Respectively; 2.12 M (7'), 4.58 M (15'), 6.4 M (21')

Hand Pump 314979-1

Foot Pump 523199-3

Electric-Hydraulic Pump; 69120-2

*Image representative of type only*



Part Number	Description	mm <sup>2</sup> (AWG) or other
58445-1	Head without dies	

## Battery-Hydraulic Tool 100 KN

1-1579002-9 with closed head design

The listed Hex crimp Dies conform to DIN 48083

Lugs to be applied should conform to DIN 46235

*Image representative of type only*

### Features:

Fast battery re-charge in 15 minutes

50 cycles approx. with one charge

Rotating head for easy access

Kit Includes: (Spare part PN)

Tool + Head

Battery charger (7-1579005-7)

Battery (7-1579005-8)

Carry Case (8-1579005-0)

Foam inlay (8-1579005-1)



### Option:

Bench-mount 7-1579005-9

Part Number	Description	mm <sup>2</sup> (AWG) or other
3-1579009-1	Die-set - Indent Crimp for Cable Lugs	10.0 (8)
5-1579009-4	Die-set - Indent Crimp for Cable Lugs	120.0 (4/0)
3-1579009-2	Die-set - Indent Crimp for Cable Lugs	16.0 mm <sup>2</sup>
3-1579009-3	Die-set - Indent Crimp for Cable Lugs	25.0 (4)
5-1579009-1	Die-set - Indent Crimp for Cable Lugs	25.0 (4)
3-1579009-4	Die-set - Indent Crimp for Cable Lugs	35.0 (2)
3-1579009-5	Die-set - Indent Crimp for Cable Lugs	50.0 mm <sup>2</sup>
5-1579009-2	Die-set - Indent Crimp for Cable Lugs	6.0 (10)
3-1579009-6	Die-set - Indent Crimp for Cable Lugs	70.0 mm <sup>2</sup>
5-1579009-3	Die-set - Indent Crimp for Cable Lugs	95.0 mm <sup>2</sup>
1-1579009-6	Die-set - 7mm thick; Hex Crimp for Tubular & Cast Cable/Battery Lugs	Al 300 mm <sup>2</sup>
1579009-3	Die-set - 7mm thick; Hex Crimp for Tubular & Cast Cable/Battery Lugs	Cu 10 mm <sup>2</sup>
1-1579009-7	Die-set - 14mm thick; Hex Crimp for Tubular & Cast Cable/Battery Lugs	Cu 10 mm <sup>2</sup>
1-1579009-0	Die-set - 7mm thick; Hex Crimp for Tubular & Cast Cable/Battery Lugs	Cu 120 mm <sup>2</sup>
2-1579009-4	Die-set - 14mm thick; Hex Crimp for Tubular & Cast Cable/Battery Lugs	Cu 120 mm <sup>2</sup>
1-1579009-2	Die-set - 7mm thick; Hex Crimp for Tubular & Cast Cable/Battery Lugs	Cu 150 mm <sup>2</sup> ; Al 95-120 mm <sup>2</sup>
2-1579009-5	Die-set - 14mm thick; Hex Crimp for Tubular & Cast Cable/Battery Lugs	Cu 150 mm <sup>2</sup> ; Al 95-120 mm <sup>2</sup>
1579009-4	Die-set - 7mm thick; Hex Crimp for Tubular & Cast Cable/Battery Lugs	Cu 16 mm <sup>2</sup> ; Al 10 mm <sup>2</sup>
1-1579009-8	Die-set - 14mm thick; Hex Crimp for Tubular & Cast Cable/Battery Lugs	Cu 16 mm <sup>2</sup> ; Al 10 mm <sup>2</sup>
1-1579009-3	Die-set - 7mm thick; Hex Crimp for Tubular & Cast Cable/Battery Lugs	Cu 185 mm <sup>2</sup> ; Al 150 mm <sup>2</sup>
2-1579009-6	Die-set - 14mm thick; Hex Crimp for Tubular & Cast Cable/Battery Lugs	Cu 185 mm <sup>2</sup> ; Al 150 mm <sup>2</sup>
1-1579009-4	Die-set - 7mm thick; Hex Crimp for Tubular & Cast Cable/Battery Lugs	Cu 240 mm <sup>2</sup> ; Al 185 mm <sup>2</sup>
2-1579009-7	Die-set - 14mm thick; Hex Crimp for Tubular & Cast Cable/Battery Lugs	Cu 240 mm <sup>2</sup> ; Al 185 mm <sup>2</sup>
1579009-5	Die-set - 7mm thick; Hex Crimp for Tubular & Cast Cable/Battery Lugs	Cu 25 mm <sup>2</sup>
1-1579009-9	Die-set - 14mm thick; Hex Crimp for Tubular & Cast Cable/Battery Lugs	Cu 25 mm <sup>2</sup>
1-1579009-5	Die-set - 7mm thick; Hex Crimp for Tubular & Cast Cable/Battery Lugs	Cu 300 mm <sup>2</sup> ; Al 240 mm <sup>2</sup>
2-1579009-8	Die-set - 14mm thick; Hex Crimp for Tubular & Cast Cable/Battery Lugs	Cu 300 mm <sup>2</sup> ; Al 240 mm <sup>2</sup>
1579009-6	Die-set - 7mm thick; Hex Crimp for Tubular & Cast Cable/Battery Lugs	Cu 35 mm <sup>2</sup> ; Al 16-25 mm <sup>2</sup>
2-1579009-0	Die-set - 14mm thick; Hex Crimp for Tubular & Cast Cable/Battery Lugs	Cu 35 mm <sup>2</sup> ; Al 16-25 mm <sup>2</sup>
1579009-7	Die-set - 7mm thick; Hex Crimp for Tubular & Cast Cable/Battery Lugs	Cu 50 mm <sup>2</sup> ; Al 35 mm <sup>2</sup>
2-1579009-1	Die-set - 14mm thick; Hex Crimp for Tubular & Cast Cable/Battery Lugs	Cu 50 mm <sup>2</sup> ; Al 35 mm <sup>2</sup>
1579009-8	Die-set - 7mm thick; Hex Crimp for Tubular & Cast Cable/Battery Lugs	Cu 70 mm <sup>2</sup> ; Al 50 mm <sup>2</sup>
2-1579009-2	Die-set - 14mm thick; Hex Crimp for Tubular & Cast Cable/Battery Lugs	Cu 70 mm <sup>2</sup> ; Al 50 mm <sup>2</sup>
1579009-9	Die-set - 7mm thick; Hex Crimp for Tubular & Cast Cable/Battery Lugs	Cu 95 mm <sup>2</sup> ; Al 70 mm <sup>2</sup>
2-1579009-3	Die-set - 14mm thick; Hex Crimp for Tubular & Cast Cable/Battery Lugs	Cu 95 mm <sup>2</sup> ; Al 70 mm <sup>2</sup>

where listed, only popular tools show - please use our online search for the latest information:

<http://www.tooling.tycoelectronics.com/europe/Handtools.asp>



## Heavy duty Electric Hydraulic Pump

**Features:**

Built for continuous use  
 Tank capacity = 11.37 liters (2.5 gallons)  
 Weight = 25 kg (65 Lbs)  
 90-95 dBA

Accessories - see 409-10081

*Image representative of type only*



Part Number	Description	mm <sup>2</sup> (AWG) or other
69120-2	Heavy duty Electric Hydraulic Pump - 580 Bar (8,200 psi) 220v	
1804700-2	Heavy duty Electric Hydraulic Pump - 700 Bar (10,000 psi) 220v	

## Electric Hydraulic Pump, light duty

**Features:**

Lightweight and compact design 10 kg  
 Large Carry-handle for easy portability  
 Two speed cycle reduces cycle time for improved productivity  
 24 v DC remote motor control, 3m length for operator safety  
 Starts under full load  
 High strength moulded shroud  
 Supplied with male quick coupler (no hose supplied)

Pressure Gauge options:  
 523200-1 Pressure Gauge  
 523200-2 Digital Pressure Gauge  
 523200-3 1/4" Adapter (required when using either Gauge)

*Image representative of type only*



Part Number	Description	mm <sup>2</sup> (AWG) or other
523199-1	Portable pump 700 bar (10,000 psi) suitable for intermittent duty cycle	

## Hydraulic Hand Pump

**Features:**

This pump action unit allows hydraulic heads via optional length hydraulic hoses a degree of positional flexibility

*Image representative of type only*



Part Number	Description	mm <sup>2</sup> (AWG) or other
1583661-1	Hand Pump 700 bar (10,000 psi)	

## Hydraulic Foot Pump

580 (8,500 psi) & 700 bar (10,000 psi) options

*Image representative of type only*

### Features:

- Pump action operation
- Clicker valve pressure regulation
- Supplied with male quick-coupling



Part Number	Description	mm <sup>2</sup> (AWG) or other
523199-2	Max pressure rating 700 bar (10,000 psi)	
523199-3	Max pressure rating 580 bar (8,500 psi)	

## Group Cutter

1490498-1

*Image representative of type only*

### Features:

- Suitable for Copper or Aluminum, solid or stranded to 35 mm<sup>2</sup> (2 awg) and Coax to RG 9
- Steel handles lock together for safe storage
- Non-slip plastic handle grips
- Not for Steel or ACSR cable



## Cable Cutter 350 mcm

605744-1

*Image representative of type only*

### Features:

- Suitable for Copper or Aluminum, solid or stranded to 185 mm<sup>2</sup> (350 MCM)
- Steel Handles
- Non-slip plastic handle grips
- Not for Steel or ACSR cable



## Cable Cutter 500 mcm

605742-1

**Features:**

Suitable for Copper or Aluminum, solid or stranded to 300 mm<sup>2</sup> (500 MCM)  
Fibreglass Handles  
Non-slip plastic handle grips  
Not for Steel or ACSR cableto

*Image representative of type only*

## Cable Cutter 350 mcm with Ratchet

1490489-1

**Features:**

Suitable for Copper or Aluminum, solid or stranded to 180 mm<sup>2</sup> (350 MCM)  
Handles lock together for safe storage  
Ratchet mechanism keeps handle force low  
Non-slip plastic handle grips  
Not for Steel or ACSR cable

*Image representative of type only*

## Cable Cutter 500 mcm with Ratchet

607453-2

**Features:**

Suitable for Copper or Aluminum, solid or stranded to 300 mm<sup>2</sup> (500 MCM)  
Fibreglass Handles  
Non-slip plastic handle grips  
Not for Steel or ACSR cable

*Image representative of type only*

## Cable Cutters SH Range

A range of heavy duty Cable Cutting tools

### Features:

- Very compact and lightweight
- One handed - low handle closing force
- Burr free cutting
- Lockable cutting stroke
- Non-slip plastic hand grips

*Image representative of type only*



Part Number	Description	mm <sup>2</sup> (AWG) or other
734045-1	solid and stranded copper and aluminium cables	Solid Cu 185 mm <sup>2</sup> Solid Al 185 mm <sup>2</sup> Stranded Cu / Al Ø52 Hi Flex Cu Ø52
169415-1	Solid and stranded copper and aluminium cables	Solid Cu 185 mm <sup>2</sup> Solid Al 240 mm <sup>2</sup> Stranded Cu / Al Ø25 Hi Flex Cu Ø32
1-1579002-8	solid and stranded copper and aluminium cables (no ASCR)	Solid Cu 480 mm <sup>2</sup> Solid Al 480 mm <sup>2</sup> Stranded Cu / Al Ø54