

# SPECIFICATION CONTROL DRAWING

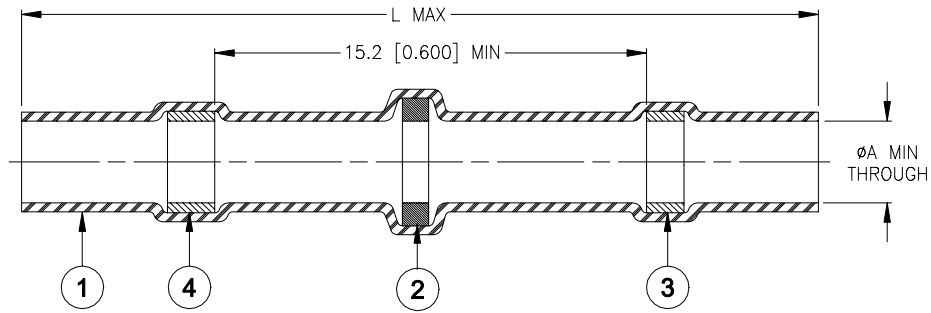

Product Revision	Size Code	Color	Product Dimensions		Conductor Dimensions		Selection Guide				Qty: Item 2
			L max	$\phi A$ min	$\phi B$		Total mm <sup>2</sup>		Total CMA		
Product Name	Items 3				min	max	min	max	min	max	
B-155-9001	A	Clear	26.0 [1.025]	1.7 [0.065]	0.4 [0.015]	1.7 [0.065]	0.3	0.8	450	1500	1
B-155-9002	A	Red	42.0 [1.655]	2.7 [0.105]	1.3 [0.050]	2.7 [0.105]	0.8	2.0	1250	3500	2
B-155-9003	A	Blue		4.5 [0.180]	1.8 [0.070]	4.5 [0.180]	2.0	4.0	2500	7200	2
B-155-9004	A	Yellow		6.0 [0.235]	2.8 [0.110]	6.0 [0.235]	4.0	6.0	6100	19000	2
B-155-9005	A	Grey		7.0 [0.275]	3.2 [0.125]	7.0 [0.275]	6.0	10.0	12000	25000	2

### MATERIALS

- INSULATION SLEEVE: Heat-shrinkable, transparent clear, radiation cross-linked modified polyolefin.
- SOLDER PREFORM WITH FLUX: Qty: see table (one solder washer shown).  
 SOLDER: TYPE Sn42Bi58 per ANSI / J-STD-006.  
 FLUX: TYPE ROM1 per ANSI / J-STD-004.
- MELTABLE RINGS: Thermally stabilized thermoplastic. Color: see table.

### APPLICATION

- These controlled soldering devices are designed to splice tin-plated or bare copper stranded wires rated for at least +85°C.
- Temperature range: -55°C to +125°C.
- When installed properly, it will meet the performance requirements of Tyco Electronics / Raychem Specification RT-1404.
- For installation procedure and application equipment consult RPIP-824-00.

For best results, prepare the wires as shown:

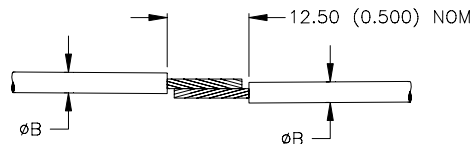

		Tyco Electronics Corporation 300 Constitution Drive, Menlo Park, CA. 94025, U.S.A.				TITLE: <b>SOLDERSLEEVE ONE-STEP WIRE                  TERMINATOR, LEAD-FREE                  LOW TEMPERATURE</b>						
Unless otherwise specified dimensions are in millimeters. [Inches dimensions are shown in brackets]						DOCUMENT NO.: <b>B-155-90XX</b>						
TOLERANCES: 0.00 N/A 0.0 N/A 0 N/A		ANGLES: N/A ROUGHNESS IN MICRON		Tyco Electronics reserves the right to amend this drawing at any time. Users should evaluate the suitability of the product for their application.		PROD. REV.: SEE TABLE		DOC. ISSUE: 1		DATE: 30-Jun-05		
PREPARED BY: mforonda		DCR NUMBER: D050172		REPLACES: ---		CAGE CODE : 06090		SCALE: ---		SIZE: A		SHEET: 1 of 1

© 2005 Tyco Electronics Corporation. All rights reserved.  
 If this document is printed it becomes uncontrolled. Check for the latest revision.