

PIDG FASTON Tabs

DESCRIPTION

Issued 11/03 1654801

- AMP PIDG FASTON tabs consist of a solid metal tab with plastic insulation on the crimp end. The metal support sleeve under the insulation crimps tightly onto the wire insulation, providing superior performance in high vibration environments.
- Individual wire strands of the lead are crimped in the wire barrel of the terminal, providing a superior mechanical and electrical connection.
- Color-coded insulation protects the crimped connection from shorting adjacent electrical sources and provides visual identification of the wire size.

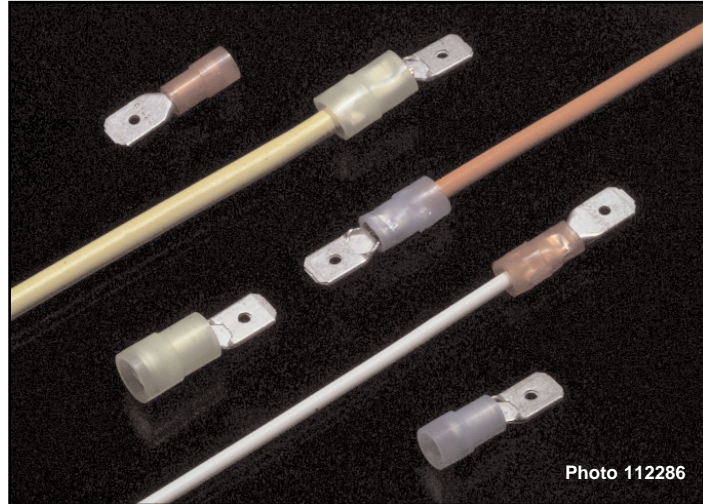

APPLICATIONS

- In-line splicing using FASTON Tab and Ultra-Fast Fully Insulated FASTON Receptacles
- Wiring harnesses
- Control units
- Any equipment needing a tab connector

KEY FEATURES

- Color-coded insulation sleeve provides visual identification of wire size
- Product is available to accommodate 22 to 10 AWG wire sizes
- .250 x .032 [6.35mm x .81mm] tab
- Metal insulation support sleeve provides wire strain relief in high vibration environments

ELECTRICAL

- Meets the requirements of UL 310 and CSA 22.2 No. 153
- Operating Voltage: 300V max.

MECHANICAL

- Meets the requirements of UL 310 and CSA 22.2 No. 153

FOR MORE INFORMATION

Technical Support

Internet: www.tycoelectronics.com
E-mail: newproducts@tycoelectronics.com

USA: 1-800-522-6752
Canada: 1-905-470-4425
Mexico: 01-800-733-8926
C. America: 52-55-5-792-0425

South America: 55-11-3611-1514
Hong Kong: 852-2735-1628
Japan: 81-44-844-8013
UK: 44-141-810-8967

new product

PIDG FASTON Tabs

MATERIALS

- Metal sleeve: Tin-plated copper
- Plastic insulator: Nylon
- Tab: Tin-plated brass

STANDARDS & SPECS

- UL 310 and CSA 22.2 No. 153
- Component Recognized by UL File No. E66717 and CSA Certified File No. LR7189

PRODUCT DIMENSIONS

Dimensions are in inches and millimeters unless otherwise specified. Values in brackets are metric equivalents.

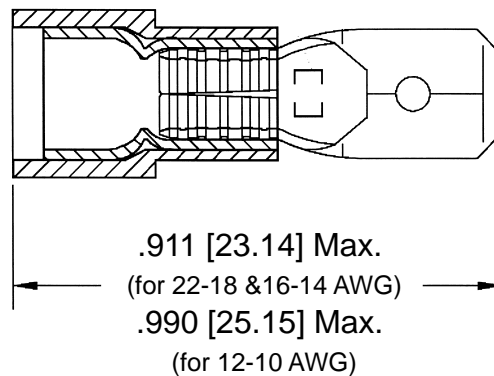

PRODUCT OFFERING

- Tab, .250 x .032 [6.35 x .81]

Wire Size	Part No.	Package Type
22-18	696362-1	Loose Piece
16-14	696369-1	Loose Piece
12-10	696372-1	Loose Piece