



ALL RIGHTS RESERVED. NO PORTION OF THIS PUBLICATION, WHETHER IN WHOLE OR IN PART CAN BE REPRODUCED WITHOUT THE EXPRESS WRITTEN CONSENT OF SPC TECHNOLOGY.

SPC-F005.DWG

REVISIONS

DOC. NO. SPC-F005 * Effective: 7/8/02 * DCP No: 1398

DCP #	REV	DESCRIPTION	DRAWN	DATE	CHECKD	DATE	APPRVD	DATE
242	B	REDRAWN	DJC	7/10/98	JC	7/24/98	JWM	7/30/98
1879	C	Update To RoHS Compliant	BYF	12/26/05	HO	1/18/06	HO	1/18/06

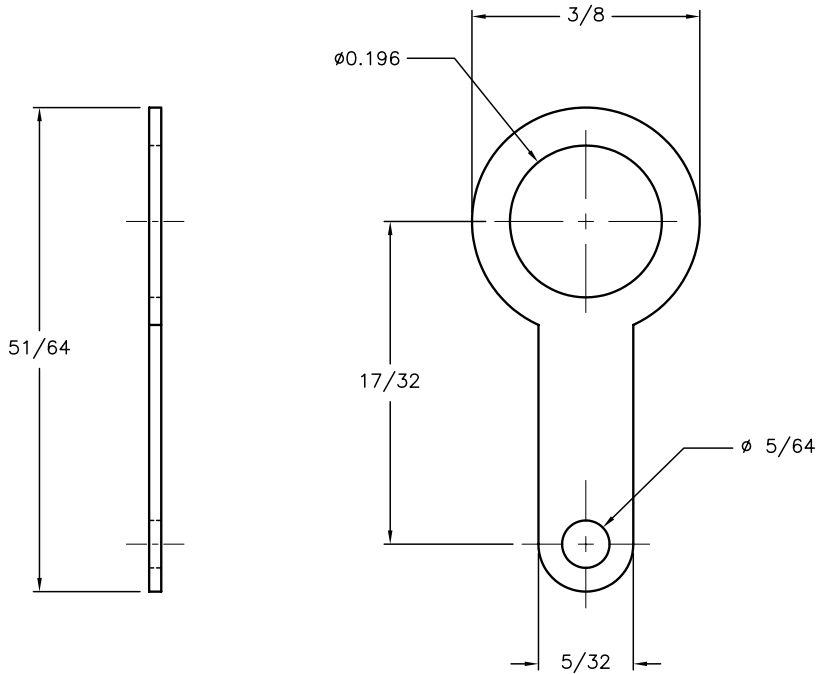

SPECIFICATIONS:
 - MATERIAL: 0.020 BRASS
 - FINISH: MATT ACID TIN

DISCLAIMER:
 ALL STATEMENTS AND TECHNICAL INFORMATION CONTAINED HEREIN ARE BASED UPON INFORMATION AND/OR TESTS WE BELIEVE TO BE ACCURATE AND RELIABLE. SINCE CONDITIONS OF USE ARE BEYOND OUR CONTROL, THE USER SHALL DETERMINE THE SUITABILITY OF THE PRODUCT FOR THE INTENDED USE AND ASSUME ALL RISK AND LIABILITY WHATSOEVER IN CONNECTION THEREWITH.

TOLERANCES:

UNLESS OTHERWISE SPECIFIED.
 FRACTIONAL ± 1/2
 DECIMALS XXX. ±0.005
 ANGULAR ± 2°
 HOLE: +0.003
 -0.002

DRAWN BY:	DATE:
JOHN COLE	9/27/91
CHECKED BY:	DATE:
(PRE DCP)	
APPROVED BY:	DATE:
(PRE DCP)	

DRAWING TITLE:			
Flat Solder Lug			
SIZE	DWG. NO.	ELECTRONIC FILE	REV
A	29-196-MT	50N443.DWG	C
SCALE:	U.O.M.:	SHEET:	
NTS	INCHES	1 OF 1	