

MATERIAL NO. LOOSE PIECE	ENG. NO.	STUD SIZE	±.003 "S"	STOCK THICKNESS
191930237	E-359-14	1/4	.265	.050/(1.27) (B)
191930240	E-359-56	5/16	.328	
191930239	E-359-38	3/8	.390	
191930242	E-359-76	7/16	.453	
191930236	E-359-12	1/2	.515	
191930241	E-359-58	5/8	.656	
191930238	E-359-34	3/4	.781	

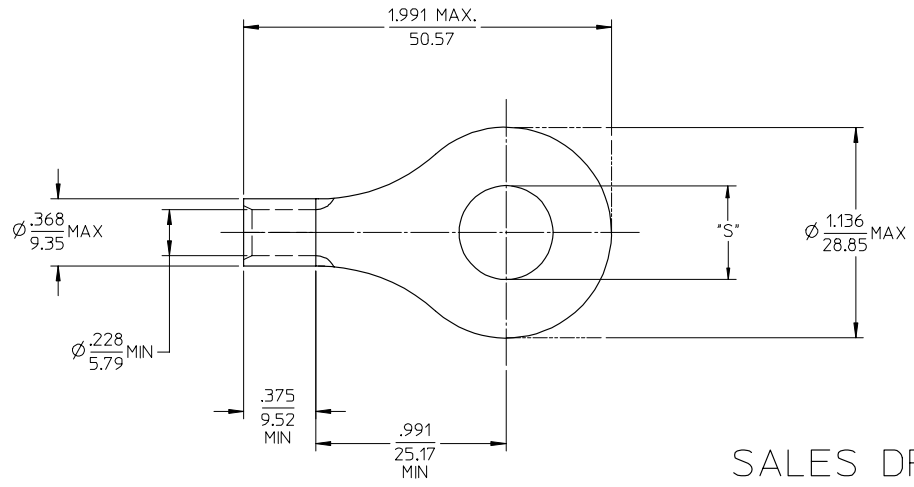

SALES DRAWING

- NOTE(S):
1. MATERIAL: COPPER
 2. PLATING: ELECTROPLATE TIN
 3. ALL DIMENSIONS IN INCHES/(MM).
 4. WIRE SIZE: 6 AWG
16 MM²
- (B) 5. PART IS ROHS COMPLIANT.

REVISED MATL THKNS EC NO: ETC2007-0003 DRAWN BY: DORNEHILLE 2006/07/12 CHKCD: MACNEIL 2006/07/19 APPROVED BY: APPERBERGSS 2006/07/26	QUALITY SYMBOLS	GENERAL TOLERANCES (UNLESS SPECIFIED)	DIMENSION STYLE	SCALE	DESIGN UNITS	THIRD ANGLE PROJECTION															
	$\nabla=0$ $\sphericalangle=0$	<table border="1"> <thead> <tr> <th></th> <th>mm</th> <th>INCH</th> </tr> </thead> <tbody> <tr> <td>4 PLACES</td> <td>± ---</td> <td>± ---</td> </tr> <tr> <td>3 PLACES</td> <td>± ---</td> <td>± .005</td> </tr> <tr> <td>2 PLACES</td> <td>± 0.13</td> <td>± .01</td> </tr> <tr> <td>1 PLACE</td> <td>± 0.25</td> <td>± ---</td> </tr> </tbody> </table>		mm	INCH	4 PLACES	± ---	± ---	3 PLACES	± ---	± .005	2 PLACES	± 0.13	± .01	1 PLACE	± 0.25	± ---	IN/MM	2:1	INCH	
		mm	INCH																		
	4 PLACES	± ---	± ---																		
3 PLACES	± ---	± .005																			
2 PLACES	± 0.13	± .01																			
1 PLACE	± 0.25	± ---																			
DRAFT WHERE APPLICABLE MUST REMAIN WITHIN DIMENSIONS	<table border="1"> <tr> <td>DRAWN BY</td> <td>DATE</td> <td>TITLE</td> </tr> <tr> <td>DLM</td> <td>03/07/28</td> <td>RING TONGUE TERMINAL VERSAKRIMP SERIES 6 AWG</td> </tr> <tr> <td>CHECKED BY</td> <td>DATE</td> <td></td> </tr> <tr> <td>HEB</td> <td>03/07/28</td> <td></td> </tr> <tr> <td>APPROVED BY</td> <td>DATE</td> <td></td> </tr> <tr> <td>RWD</td> <td>03/07/28</td> <td></td> </tr> </table>	DRAWN BY	DATE	TITLE	DLM	03/07/28	RING TONGUE TERMINAL VERSAKRIMP SERIES 6 AWG	CHECKED BY	DATE		HEB	03/07/28		APPROVED BY	DATE		RWD	03/07/28		MOLEX INCORPORATED SEE CHART MATERIAL NO. _____ DOCUMENT NO. SD-19193-031	SHEET NO.
DRAWN BY	DATE	TITLE																			
DLM	03/07/28	RING TONGUE TERMINAL VERSAKRIMP SERIES 6 AWG																			
CHECKED BY	DATE																				
HEB	03/07/28																				
APPROVED BY	DATE																				
RWD	03/07/28																				
REV	DESCRIPTION	SIZE	THIS DRAWING CONTAINS INFORMATION THAT IS PROPRIETARY TO MOLEX INCORPORATED AND SHOULD NOT BE USED WITHOUT WRITTEN PERMISSION			1 OF 1															