

160-3653 Solder terminal, turreted

Recommended mounting hole .067 (1,70), #51 drill

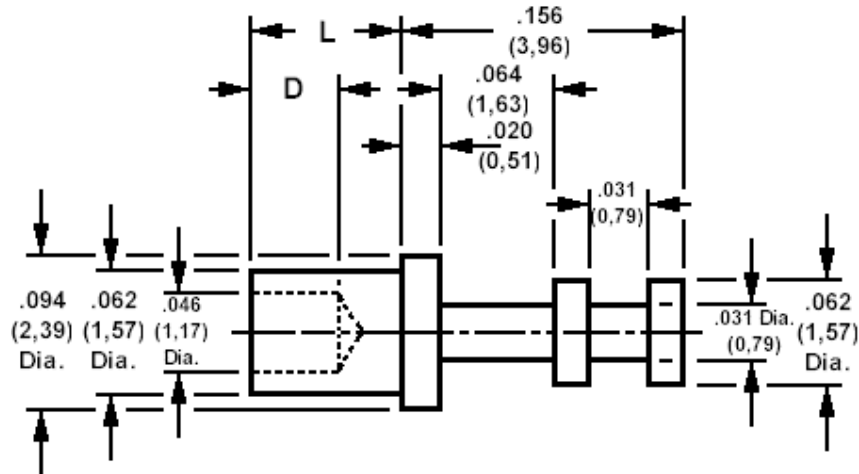

How to order code

160-3653-XX-YY-00

Basic Part No XX = L dimension, YY = Plating Finish

DIMENSIONS (XX)				
Basic Part No	(XX)	L	Board Thickness	D
160-3653	-11	.037 (0,94)	.016 (0,40)	.025 (0,64)
	-01	.053 (1,35)	.031 (0,79)	.045 (1,14)
	-02	.084 (2,13)	.062 (1,58)	.045 (1,14)
	-03	.115 (2,92)	.094 (2,38)	.045 (1,14)
	-04	.147 (3,73)	.125 (3,18)	.045 (1,14)

MATERIALS				
Component	Material	Finish (YY)		
		-01	-03	-05
Terminal	Brass	Silver	Gold	Electro Solder

SWAGE TOOLING	
Recommended Swaging Tools:-	
Anvil	435-6411-01-00-00
Roll punch	435-6611-01-00-00
Flare punch	435-6657-01-00-00