

FEMALE-FEMALE SQUARE FLANGE ADAPTOR

R141.710.000

Series : BNC

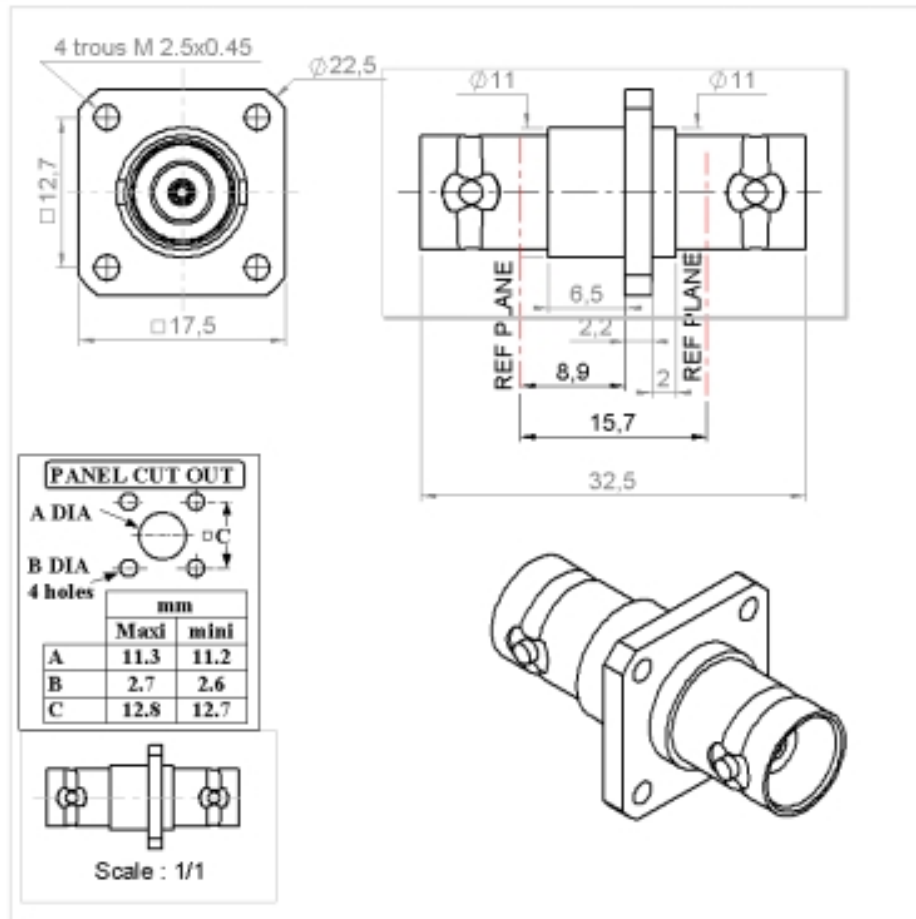

All dimensions are in mm.



COMPONENTS	MATERIALS	PLATINGS (µm)
BODY	BRASS	NICKEL 2
CENTER CONTACT	BERYLLIUM COPPER	GOLD 0.5 OVER NICKEL 2
OUTER CONTACT	-	-
INSULATOR	PTFE	-
GASKET	-	-
OTHERS PARTS	-	-
-	-	-
-	-	-

Issue : 0326 U

In the effort to improve our products, we reserve the right to make changes judged to be necessary.



FEMALE-FEMALE SQUARE FLANGE ADAPTOR

R141.710.000

Series : **BNC**

PACKAGING

Standard	Unit	Other
100	'W' option	Contact us

SPECIFICATION

ELECTRICAL CHARACTERISTICS

Impedance		50 Ω
Frequency		0-4 GHz
VSWR	1.25 +	0.000 x F(GHz) Maxi
Insertion loss		0.115 √F(GHz) dB Maxi
RF leakage	- (57 - F(GHz)) dB Maxi
Voltage rating		500 Veff Maxi
Dielectric withstanding voltage		1500 Veff mini
Insulation resistance		5000 MΩ mini

ENVIRONMENTAL

Operating temperature	-65/+165 ° C
Hermetic seal	NA Atm.cm3/s
Panel leakage	NA

OTHERS CHARACTERISTICS

Assembly instruction **NA**

Others :
-

MECHANICAL CHARACTERISTICS

Center contact retention		
Axial force – Mating end	18	N mini
Axial force – Opposite end	18	N mini
Torque	2.8	N.cm mini
Recommended torque		
Mating	NA	N.cm
Panel nut	NA	N.cm
Mating life	500	Cycles mini
Weight	12.000	g

Issue : 0326 U

In the effort to improve our products, we reserve the right to make changes judged to be necessary.

