

SMB MALE - BNC FEMALE
SQUARE FLANGE STRAIGHT ADAPTER

R191.212.000

Série : ADAPT

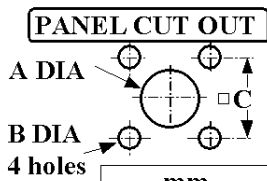
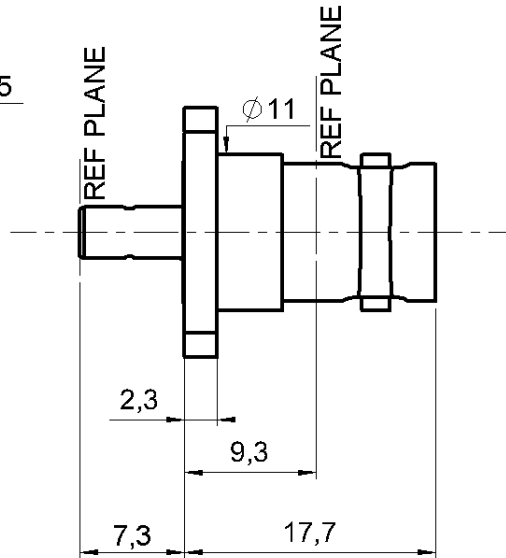
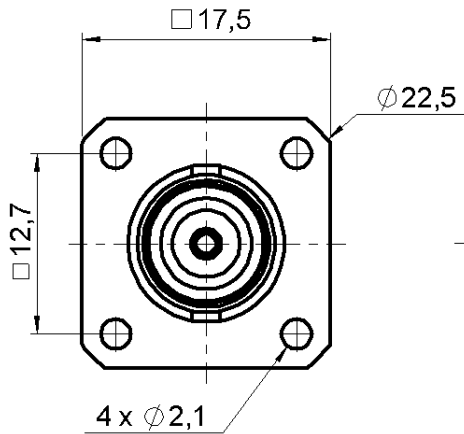

	mm	
	Maxi	mini
A	11.3	11.2
B	2.7	2.6
C	12.75	12.65

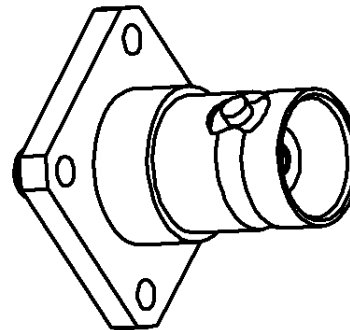
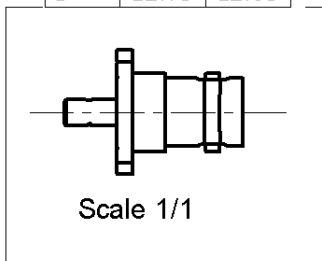

All dimensions are in mm.



COMPONENTS	MATERIALS	PLATINGS (µm)
BODY	BRASS	NICKEL 2
CENTER CONTACT	BERYLLIUM COPPER	GOLD 1.3 OVER NICKEL 2
OUTER CONTACT	-	-
INSULATOR	PTFE	-
GASKET	-	-
OTHERS PARTS	BRASS	NICKEL 2
-	-	-
-	-	-

Issue : 0303 X

In the effort to improve our products, we reserve the rights to make changes judged to be necessary.



SMB MALE - BNC FEMALE
SQUARE FLANGE STRAIGHT ADAPTER

R191.212.000

Série : ADAPT

PACKAGING

Standard	Unit	Other
1	-	Contact us

SPECIFICATION

ELECTRICAL CHARACTERISTICS

Impedance		50 Ω
Frequency		0-4 GHz
VSWR	1.2 +	0.000 x F(GHz) Maxi
Insertion loss		0.250 √F(GHz) dB Maxi
RF leakage	- (57 - F(GHz)) dB Maxi
Voltage rating		500 Veff Maxi
Dielectric withstanding voltage		1000 Veff mini
Insulation resistance		1000 MΩ mini

ENVIRONMENTAL

Operating	-55/+155 ° C
Hermetic seal	NA Atm.cm3/s
Panel leakage	NA

MECHANICAL CHARACTERISTICS

Center contact retention		
Axial force – Mating end		10 N mini
Axial force – Opposite end		10 N mini
Torque		NA N.cm mini
Recommended torque		
Mating	SMB	0 N.cm
	BNC	0 N.cm
	-	0 N.cm
Panel nut		NA N.cm
Mating life		500 Cycles mini
Weight		13.000 g

OTHERS CHARACTERISTICS

Issue : 0303 X

In the effort to improve our products, we reserve the rights to make changes judged to be necessary.

