

**TEE FEMALE-FEMALE/MALE ADAPTER**

**R142.780.000**

Series : **BNC 75**

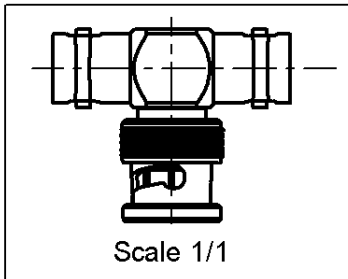
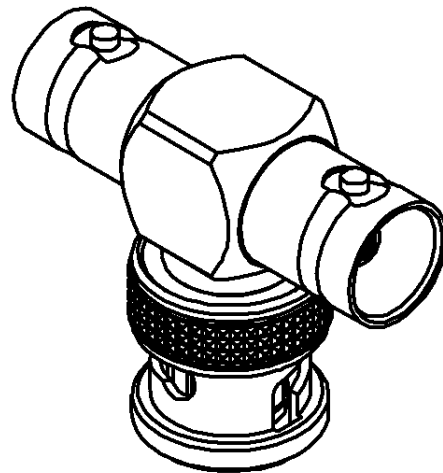
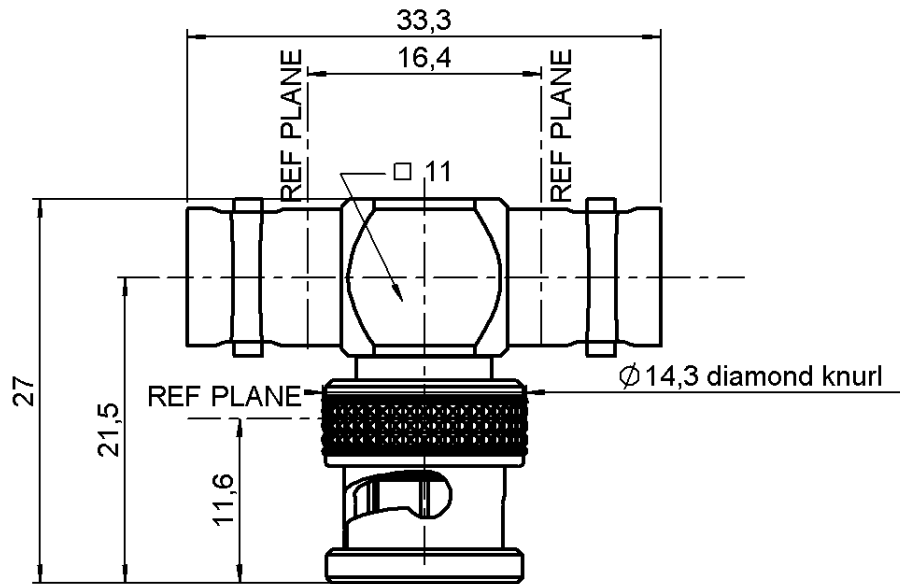

All dimensions are in mm.



COMPONENTS	MATERIALS	PLATINGS (µm)
BODY	BRASS	NICKEL 2
CENTER CONTACT	BERYLLIUM COPPER, BRASS	GOLD 0.5 OVER NICKEL 2
OUTER CONTACT	-	-
INSULATOR	PTFE	-
GASKET	SILICONE RUBBER	-
OTHERS PARTS	BRASS	NICKEL 2
-	-	-
-	-	-

Issue : 9905 D

In the effort to improve our products, we reserve the right to make changes judged to be necessary.



**TEE FEMALE-FEMALE/MALE ADAPTER**

**R142.780.000**

Series : **BNC 75**

**PACKAGING**

Standard	Unit	Other
<b>100</b>	<b>'W' option</b>	<b>Contact us</b>

**SPECIFICATION**

**ELECTRICAL CHARACTERISTICS**

Impedance		<b>75</b> Ω
Frequency		<b>0-1.5</b> GHz
VSWR	<b>NA</b> +	<b>0.000</b> x F(GHz) Maxi
Insertion loss		<b>0.175</b> √F(GHz) dB Maxi
RF leakage	- (	<b>57</b> - F(GHz)) dB Maxi
Voltage rating		<b>500</b> Veff Maxi
Dielectric withstanding voltage		<b>1500</b> Veff mini
Insulation resistance		<b>5000</b> MΩ mini

**ENVIRONMENTAL**

Operating temperature	<b>-65/+165</b> ° C
Hermetic seal	<b>NA</b> Atm.cm3/s
Panel leakage	<b>NA</b>

**OTHERS CHARACTERISTICS**

Assembly instruction **NA**

Others :  
-

**MECHANICAL CHARACTERISTICS**

Center contact retention		
Axial force – Mating end	<b>18</b>	N mini
Axial force – Opposite end	<b>18</b>	N mini
Torque	<b>2.8</b>	N.cm mini
Recommended torque		
Mating	<b>NA</b>	N.cm
Panel nut	<b>NA</b>	N.cm
Mating life	<b>500</b>	Cycles mini
Weight	<b>0.000</b>	g

**Issue : 9905 D**

In the effort to improve our products, we reserve the right to make changes judged to be necessary.

