

**STRAIGHT PLUG CRIMP TYPE
CABLE 5/50 S**

R143.082.000
SERIES TNC

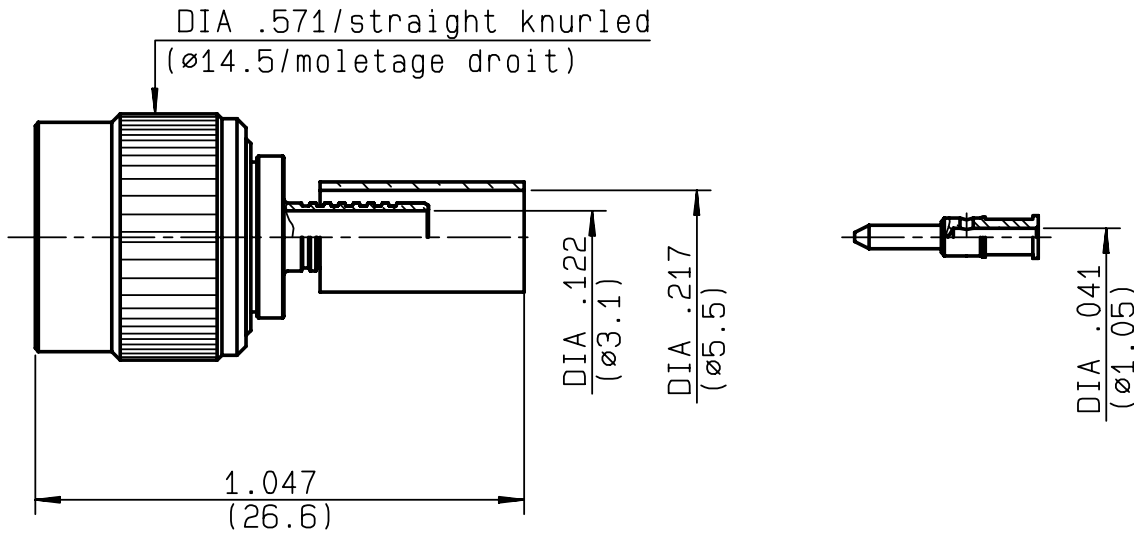

NOMINAL IMPEDANCE	50 Ω	CABLES : KX 15
FREQUENCY RANGE	0-11 GHz	RG 141
TEMPERATURE RATING	-65/+165 °C	RG 58
V.S.W.R	1.30 + 0 x F(GHz)Maxi	
RF INSERTION LOSS	0.06 √F(GHz) dB Maxi	
VOLTAGE RATING	500 Veff Maxi	
DIELECTRIC WITHSTANDING VOLTAGE	1500 Veff Mini	
INSULATION RESISTANCE	5000 M ΩMini	OTHERS CHARACTERISTICS
HERMETIC SEAL	NA Atm.cm ³ /s	CABLE RETENTION
LEAKAGE (pressurized only)	NA	90 N Mini
MECHANICAL DURABILITY	500 Cycles	CENTER CONTACT RETENTION
WEIGHT	gr	Axial force - mating end
SPECIFICATION		27 N Mini
		Axial force - opposite end
		27 N Mini
		Torque
		NA cm.N Mini
		RECOMMENDED TORQUES
		Mating
		NA cm.N
		Panel nut
		NA cm.N
		Clamp nut
		NA cm.N

CONNECTOR PARTS	MATERIALS	FINISH	(all values are given in micrometers)
BODY	BRASS	NICKEL 2	
OUTER CONTACT			
CENTER CONTACT	BRASS	GOLD 0.5 OVER NICKEL 2	
INSULATOR	PTFE	-	
GASKET	SILICONE RUBBER	-	
OTHERS PIECES	BRASS	NICKEL 2	

ISSUE	CREATION DATE	FILE PART-NUMBER
0245E00	23/11/1990	



The information given here is subject to change without notice. Design changes may be in order to improve the product .

Connect to the future

LELEU



R143.082.000

ISSUE 0245E00 SERIES TNC

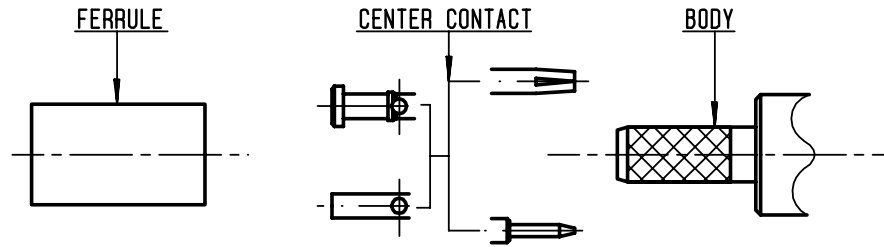

①

Slide ferrule onto cable
Strip the cable .

-
-

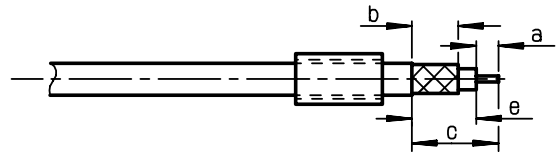

Stripping	a	b	c	d	e
inch	0.157	0.335	0.591	0	0.433
mm	4	8.5	15		11

②

Slide center contact on until it bottoms against cable dielectric .
Solder or crimp center contact .
Crimping tool : R282 223 000 (Hex. : 0.068)
or R282 293 000 (M22520/5-01)
+ dies R282 235 011 (M22520/5-11) .

-

SOLDER / CRIMPING

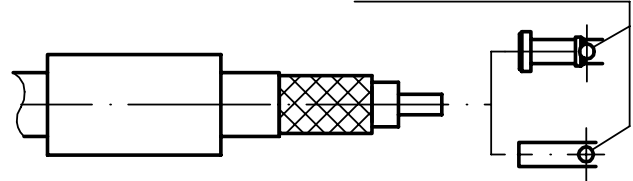

③

Fan the braid .
Slide cable into the body until bottoms against insulator .
Slide ferrule over the braid .
(In direction F)

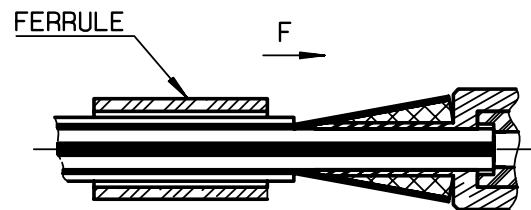

④

Crimp the ferrule with crimping tool R 282 223 000 (Hex. : 5.4) or crimping tool R282 293 000 (M22520/5-01)
+ dies R282 235 011 (M22520/5-11)
Cut excess of braid if necessary .

-
-
-
-

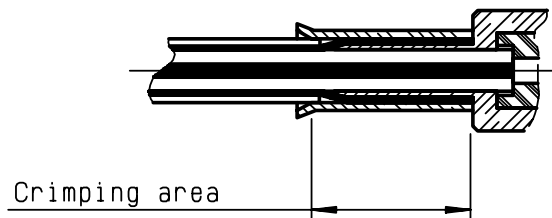

LELEU