

**STRAIGHT PLUG CRIMP-TYPE
CABLE 10/75 S**

R142.095.000
SERIES BNC 75

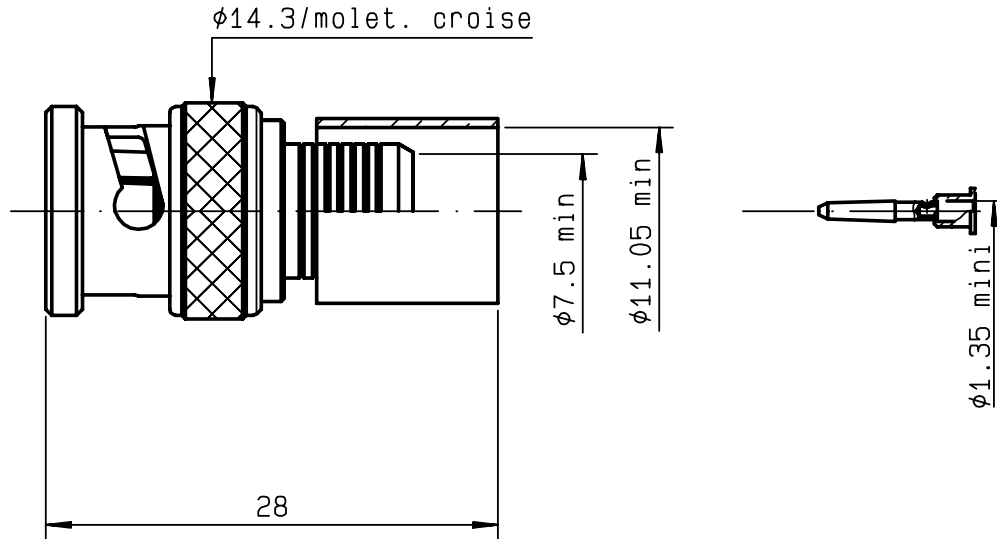

NOMINAL IMPEDANCE	75 Ω
FREQUENCY RANGE	0-1.5 GHz
TEMPERATURE RATING	-65/+165 °C
V.S.W.R	1.30 + 0 x F(GHz)Maxi
RF INSERTION LOSS	0.115 √F(GHz) dB Maxi
VOLTAGE RATING	500 Veff Maxi
DIELECTRIC WITHSTANDING VOLTAGE	1500 Veff Mini
INSULATION RESISTANCE	5000 M ΩMini
HERMETIC SEAL	NA Atm.cm ³ /s
LEAKAGE (pressurized only)	NA
MECHANICAL DURABILITY	500 Cycles
WEIGHT	gr
SPECIFICATION	

CABLES : **KX 8**
RG 11
RG 144

OTHERS CHARACTERISTICS

CABLE RETENTION	300 N Mini
CENTER CONTACT RETENTION	
Axial force - mating end	27 N Mini
Axial force - opposite end	27 N Mini
Torque	NA cm.N Mini
RECOMMENDED TORQUES	
Mating	NA cm.N
Panel nut	NA cm.N
Clamp nut	NA cm.N

CONNECTOR PARTS	MATERIALS	FINISH	(all values are given in micrometers)
BODY	BRASS	NICKEL 2	
OUTER CONTACT			
CENTER CONTACT	BRASS	GOLD 0.5 OVER NICKEL 2	
INSULATOR	PTFE	-	
GASKET	SILICONE RUBBER	-	
OTHERS PIECES	BRASS	NICKEL 2	

ISSUE	CREATION DATE	FILE PART-NUMBER
9904D00	23/04/1991	



The information given here is subject to change without notice.
Design changes may be in order to improve the product .

Connect to the future

LELEU



R142.095.000

ISSUE 9904D00 SERIES BNC 75

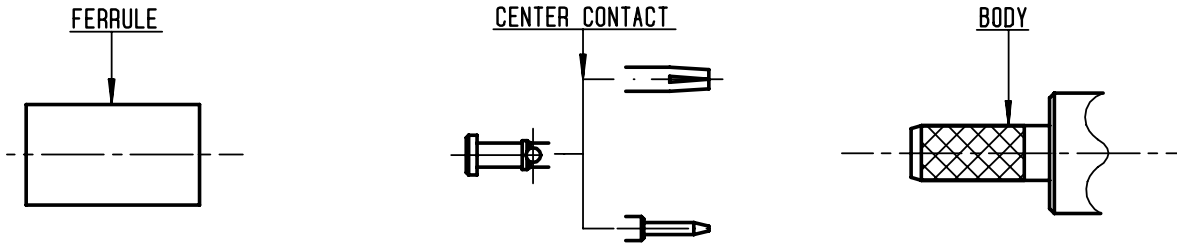

①

Slide ferrule onto cable .
Strip the cable .
-
-

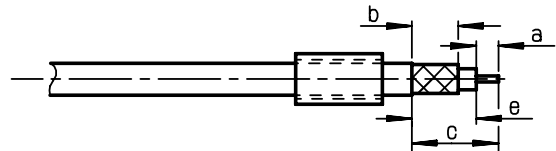

Stripping	a	b	c	d	e
inch	0.098	0.354	0.551	0	0.453
mm	2.5	9	14		11.5

②

Slide on the center contact until it bottoms against cable dielectric.
Crimp center contact, crimping tool R282.223.000 (Hex. .068) or crimping tool M22520/5-01 + dies M22520/5-11
-
-
-

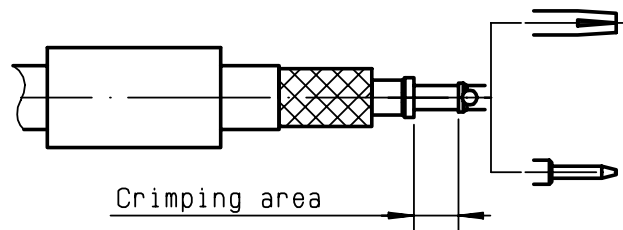

③

Open the braid
Slide cable into the body until bottoms against insulator.
Slide ferrule over the braid (In direction F)

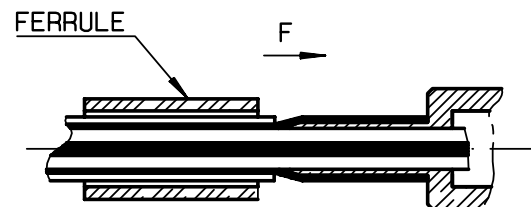

④

Crimp the ferrule with crimping tool R282.231.000 (Hex. : .415) or Crimping tool M22520/5-01 + dies Y 116 DANIELS
Cut the excess of braid
-

